

Service Manual

Digital Camera

LUMIX



AVCHD™
Progressive



Model No. **DMC-FZ300PP**
DMC-FZ300EE
DMC-FZ300EF
DMC-FZ300EG
DMC-FZ300EP
DMC-FZ300GA
DMC-FZ300GC
DMC-FZ300GD
DMC-FZ300GH
DMC-FZ300GK
DMC-FZ300GN
DMC-FZ300GT
DMC-FZ300SG
DMC-FZ330EB

Colour
(K).....Black Type

WARNING

This service information is designed for experienced repair technicians only and is not designed for use by the general public. It does not contain warnings or cautions to advise non-technical individuals of potential dangers in attempting to service a product. Products powered by electricity should be serviced or repaired only by experienced professional technicians. Any attempt to service or repair the product or products dealt with in this service information by anyone else could result in serious injury or death.

Panasonic®

© Panasonic Corporation 2015.
Unauthorized copying and distribution is a violation of law.

TABLE OF CONTENTS

	PAGE	PAGE
1 Safety Precautions	3	
1.1. General Guidelines	3	
1.2. Leakage Current Cold Check	3	
1.3. Leakage Current Hot Check (See Figure. 1)	3	
1.4. How to Discharge the E.Capacitor on Flash P.C.B. Unit	4	
2 Warning	5	
2.1. Prevention of Electrostatic Discharge (ESD) to Electrostatically Sensitive (ES) Devices	5	
2.2. How to Recycle the Lithium Ion Battery (U.S. Only)	5	
2.3. How to Replace the Lithium Battery	6	
2.4. Caution for AC Cord (For EB/GC/GH)	7	
3 Service Navigation	8	
3.1. Introduction	8	
3.2. Important Notice	8	
3.3. Service Notes	9	
3.4. General Description About Lead Free Solder (PbF)	11	
3.5. How to Define the Model Suffix (NTSC or PAL model)	12	
4 Specifications	16	
5 Location of Controls and Components	19	
6 Service Mode	21	
6.1. Error Code Memory Function	21	
7 Troubleshooting Guide	24	
7.1. Wi-Fi Module (Flash P.C.B. Unit)	24	
8 Service Fixture & Tools	25	
8.1. Service Fixture and Tools	25	
8.2. When Replacing the Main P.C.B.	26	
8.3. Service Position	26	
9 Disassembly and Assembly Instructions	27	
9.1. Disassembly Flow Chart	27	
9.2. P.C.B. Location	27	
9.3. Disassembly Procedure	28	
9.4. Lens Disassembly Procedure	42	
9.5. Removal of the MOS Unit	50	
9.6. Main exterior parts assembly procedure	51	
10 Measurements and Adjustments	52	
10.1. Introduction	52	
10.2. Before Disassembling the unit	52	
10.3. Details of Electrical Adjustment	55	
10.4. After Adjustment	62	
11 Maintenance	63	
11.1. Cleaning Lens and LCD Panel	63	
12 Block Diagram	65	
12.1. Overall Block Diagram	65	
12.2. System Control Block Diagram	66	
12.3. Video/Audio Process(1) Block Diagram	67	
12.4. Video/Audio Process(2) Block Diagram	68	
12.5. Lens/Flash Block Diagram	69	
12.6. Power(1) Block Diagram	70	
12.7. Power(2) Block Diagram	71	
13 Wiring Connection Diagram	72	
13.1. Interconnection Diagram	72	
14 Schematic Diagram	73	
15 Printed Circuit Board	73	
16 Exploded View and Replacement Parts List	73	

1 Safety Precautions

1.1. General Guidelines

1. IMPORTANT SAFETY NOTICE

There are special components used in this equipment which are important for safety. These parts are marked by



in the Schematic Diagrams, Circuit Board Layout, Exploded Views and Replacement Parts List. It is essential that these critical parts should be replaced with manufacturer's specified parts to prevent X-RADIATION, shock, fire, or other hazards. Do not modify the original design without permission of manufacturer.

2. An Isolation Transformer should always be used during the servicing of AC Adaptor whose chassis is not isolated from the AC power line. Use a transformer of adequate power rating as this protects the technician from accidents resulting in personal injury from electrical shocks. It will also protect AC Adaptor from being damaged by accidental shorting that may occur during servicing.
3. When servicing, observe the original lead dress. If a short circuit is found, replace all parts which have been overheated or damaged by the short circuit.
4. After servicing, see to it that all the protective devices such as insulation barriers, insulation papers shields are properly installed.
5. After servicing, make the following leakage current checks to prevent the customer from being exposed to shock hazards.

1.2. Leakage Current Cold Check

1. Unplug the AC cord and connect a jumper between the two prongs on the plug.
2. Measure the resistance value, with an ohmmeter, between the jumpered AC plug and each exposed metallic cabinet part on the equipment such as screwheads, connectors, control shafts, etc. When the exposed metallic part has a return path to the chassis, the reading should be between $1\text{ M}\Omega$ and $5.2\text{ M}\Omega$. When the exposed metal does not have a return path to the chassis, the reading must be infinity.

1.3. Leakage Current Hot Check (See Figure. 1)

1. Plug the AC cord directly into the AC outlet. Do not use an isolation transformer for this check.
2. Connect a $1.5\text{ k}\Omega$, 10 W resistor, in parallel with a $0.15\text{ }\mu\text{F}$ capacitor, between each exposed metallic part on the set and a good earth ground, as shown in Figure. 1.
3. Use an AC voltmeter, with $1\text{ k}\Omega/\text{V}$ or more sensitivity, to measure the potential across the resistor.
4. Check each exposed metallic part, and measure the voltage at each point.
5. Reverse the AC plug in the AC outlet and repeat each of the above measurements.
6. The potential at any point should not exceed 0.75 V RMS . A leakage current tester (Simpson Model 229 or equivalent) may be used to make the hot checks, leakage current must not exceed $1/2\text{ mA}$. In case a measurement is outside of the limits specified, there is a possibility of a shock hazard, and the equipment should be repaired and rechecked before it is returned to the customer.

Hot-Check Circuit

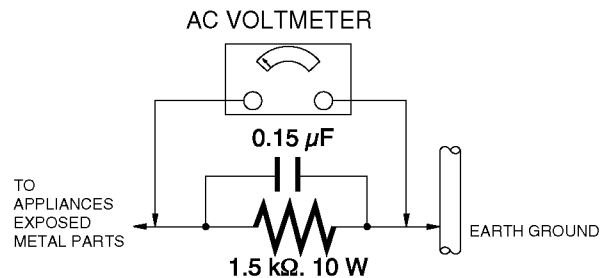

Figure. 1

1.4. How to Discharge the E.Capacitor on Flash P.C.B. Unit

CAUTION:

- Be sure to discharge the E.Capacitor on Flash P.C.B. Unit before disassembling.
- Be careful of the high voltage circuit on Flash P.C.B. Unit when servicing.

[Discharging Procedure]

1. Put the insulation tube on the lead part of resistor (ERG5SJ102:1k Ω /5W).
(An equivalent type of resistor may be used.)
2. Put the resistor between both terminals of E.Capacitor on the Flash P.C.B. Unit for approx. 5 seconds.
3. After discharging, confirm that the E.Capacitor voltage is lower than 10V by using a voltmeter.

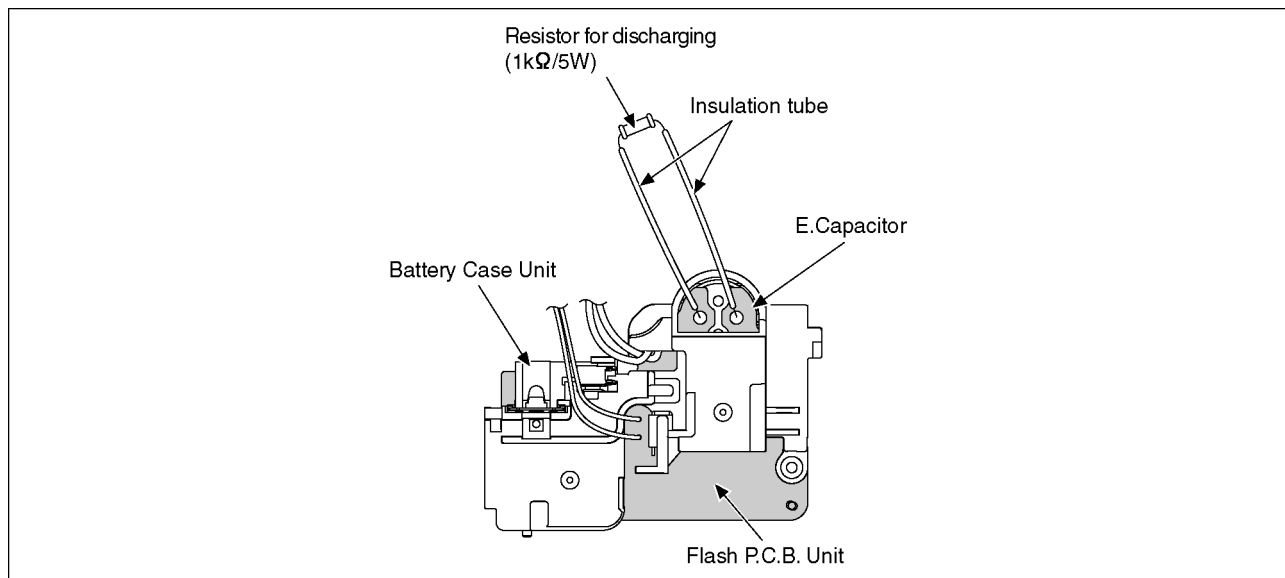

Fig. F1

2 Warning

2.1. Prevention of Electrostatic Discharge (ESD) to Electrostatically Sensitive (ES) Devices

Some semiconductor (solid state) devices can be damaged easily by static electricity. Such components commonly are called Electrostatically Sensitive (ES) Devices.

Examples of typical ES devices are MOS image sensor, IC (integrated circuits) and some field-effect transistors and semiconductor "chip" components.

The following techniques should be used to help reduce the incidence of component damage caused by electrostatic discharge (ESD).

1. Immediately before handling any semiconductor component or semiconductor-equipped assembly, drain off any ESD on your body by touching a known earth ground. Alternatively, obtain and wear a commercially available discharging ESD wrist strap, which should be removed for potential shock reasons prior to applying power to the unit under test.
2. After removing an electrical assembly equipped with ES devices, place the assembly on a conductive surface such as aluminum foil, to prevent electrostatic charge buildup or exposure of the assembly.
3. Use only a grounded-tip soldering iron to solder or unsolder ES devices.
4. Use only an antistatic solder removal device. Some solder removal devices not classified as "antistatic (ESD protected)" can generate electrical charge sufficient to damage ES devices.
5. Do not use freon-propelled chemicals. These can generate electrical charges sufficient to damage ES devices.
6. Do not remove a replacement ES device from its protective package until immediately before you are ready to install it. (Most replacement ES devices are packaged with leads electrically shorted together by conductive foam, aluminum foil or comparable conductive material).
7. Immediately before removing the protective material from the leads of a replacement ES device, touch the protective material to the chassis or circuit assembly into which the device will be installed.

CAUTION :

Be sure no power is applied to the chassis or circuit, and observe all other safety precautions.

8. Minimize bodily motions when handling unpackaged replacement ES devices. (Otherwise harmless motion such as the brushing together of your clothes fabric or the lifting of your foot from a carpeted floor can generate static electricity (ESD) sufficient to damage an ES device).

2.2. How to Recycle the Lithium Ion Battery (U.S. Only)

ENGLISH



A lithium ion battery that is recyclable powers the product you have purchased. Please call 1-800-8-BATTERY for information on how to recycle this battery.

FRANÇAIS



L'appareil que vous vous êtes procuré est alimenté par une batterie au lithium-ion recyclable. Pour des renseignements sur le recyclage de la batterie, veuillez composer le 1-800-8-BATTERY.

2.3. How to Replace the Lithium Battery

2.3.1. Replacement Procedure

1. Remove the Flash P.C.B.. (Refer to Disassembly Procedures.)
2. Unsolder the each soldering point of electric lead terminal for Lithium battery (Ref. No. "B8001" at component side of Flash P.C.B.) and remove the Lithium battery together with electric lead terminal. Then replace it into new one.

NOTE:

The Lithium battery includes electric lead terminals.

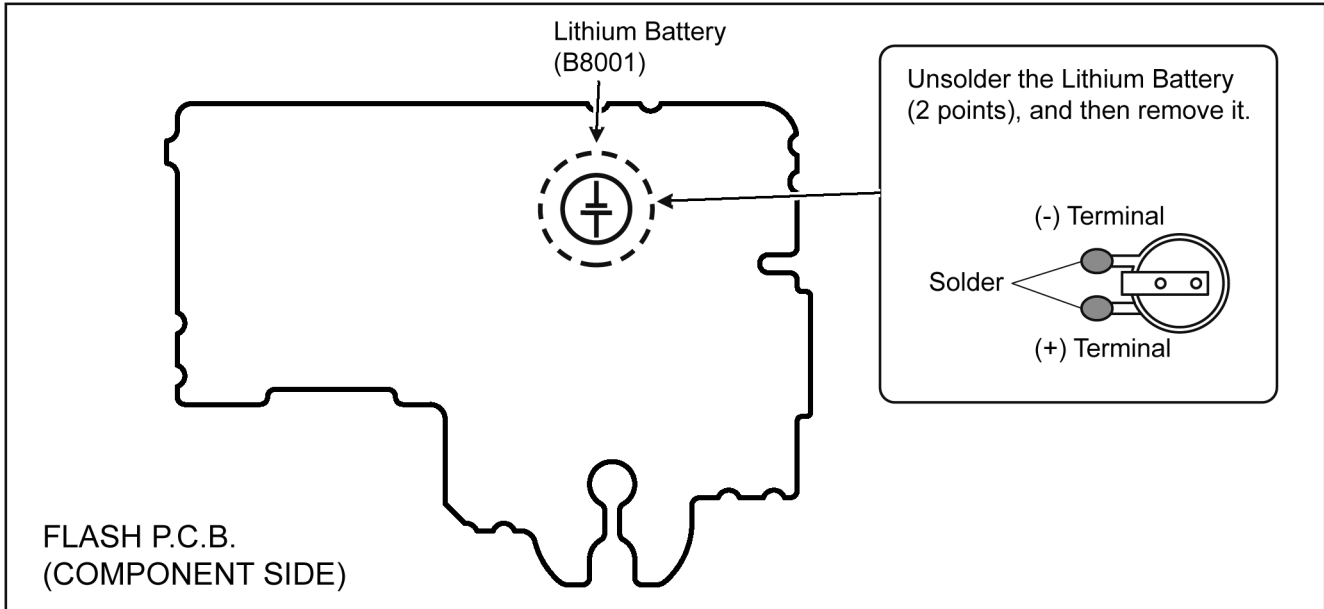

NOTE:

This Lithium battery is a critical component.

It must never be subjected to excessive heat or discharge.

It must therefore only be fitted in requirement designed specifically for its use.

Replacement batteries must be of same type and manufacture.

They must be fitted in the same manner and location as the original battery, with the correct polarity contacts observed.

Do not attempt to re-charge the old battery or re-use it for any other purpose.

It should be disposed of in waste products destined for burial rather than incineration.

(For English)

CAUTION

Danger of explosion if battery is incorrectly replaced.

Replace only with the same or equivalent type recommended by the manufacturer.

Dispose of used batteries according to the manufacturer's instructions.

(For German)

ACHTUNG

Explosionsgefahr bei falschem Anbringen der Batterie. Ersetzen Sie nur mit einem äquivalentem vom Hersteller empfohlenem Typ.

Behandeln Sie gebrauchte Batterien nach den Anweisungen des Herstellers.

(For French)

MISE EN GARDE

Une batterie de remplacement inappropriée peut exploser. Ne remplacez qu'avec une batterie identique ou d'un type recommandé par le fabricant. L'élimination des batteries usées doit être faite conformément aux instructions du fabricant.

NOTE:

Above caution is applicable for a battery pack which is for DMC-FZ300/FZ330 series, as well.

2.4. Caution for AC Cord (For EB/GC/GH)

2.4.1. Information for Your Safety

IMPORTANT

Your attention is drawn to the fact that recording of pre-recorded tapes or discs or other published or broadcast material may infringe copyright laws.

WARNING

To reduce the risk of fire or shock hazard, do not expose this equipment to rain or moisture.

CAUTION

To reduce the risk of fire or shock hazard and annoying interference, use the recommended accessories only.

FOR YOUR SAFETY

DO NOT REMOVE THE OUTER COVER

To prevent electric shock, do not remove the cover. No user serviceable parts inside. Refer servicing to qualified service personnel.

2.4.2. Caution for AC Mains Lead

For your safety, please read the following text carefully.

This appliance is supplied with a moulded three-pin mains plug for your safety and convenience.

A 5-ampere fuse is fitted in this plug.

Should the fuse need to be replaced please ensure that the replacement fuse has a rating of 5 amperes and it is approved by ASTA or BSI to BS1362

Check for the ASTA mark or the BSI mark on the body of the fuse.



If the plug contains a removable fuse cover you must ensure that it is refitted when the fuse is replaced.

If you lose the fuse cover, the plug must not be used until a replacement cover is obtained.

A replacement fuse cover can be purchased from your local Panasonic Dealer.

If the fitted moulded plug is unsuitable for the socket outlet in your home then the fuse should be removed and the plug cut off and disposed of safely.

There is a danger of severe electrical shock if the cut off plug is inserted into any 13-ampere socket.

If a new plug is to be fitted please observe the wiring code as shown below.

If in any doubt, please consult a qualified electrician.

2.4.2.1. Important

The wires in this mains lead are coloured in accordance with the following code:

Blue	Neutral
Brown	Live

As the colours of the wires in the mains lead of this appliance may not correspond with the coloured markings identifying the terminals in your plug, proceed as follows:

The wire which is coloured BLUE must be connected to the terminal in the plug which is marked with the letter N or coloured BLACK.

The wire which is coloured BROWN must be connected to the terminal in the plug which is marked with the letter L or coloured RED.

Under no circumstances should either of these wires be connected to the earth terminal of the three pin plug, marked with the letter E or the Earth Symbol.

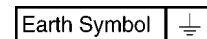

2.4.2.2. Before Use

Remove the Connector Cover as follows.

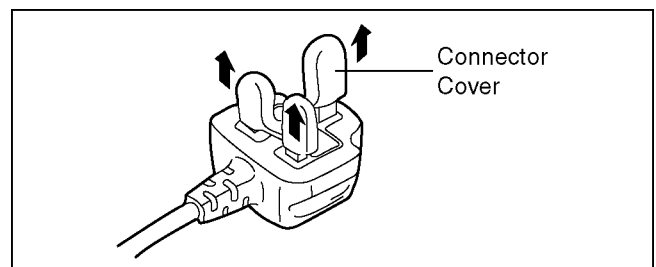

2.4.2.3. How to Replace the Fuse

1. Remove the Fuse Cover with a screwdriver.

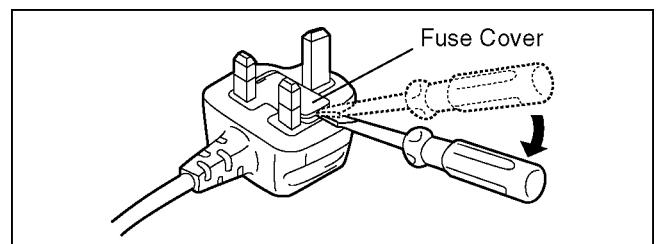

2. Replace the fuse and attach the Fuse cover.

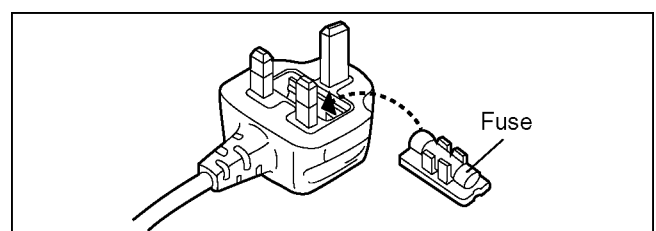

3 Service Navigation

3.1. Introduction

This service manual contains technical information, which allow service personnel's to understand and service this model.

Please place orders using the parts list and not the drawing reference numbers.

If the circuit is changed or modified, the information will be followed by service manual to be controlled with original service manual.

3.2. Important Notice

3.2.1. About Lens Block

The image sensor (MOS) Unit which are connected to the lens unit with 4 screws, after performing the Optical tilt adjustment.

During servicing, if one of MOS Unit fixing screws are loosened, the Optical tilt adjustment must be performed.

(About the Optical tilt adjustment, refer to the "10.3.2. Adjustment Specifications" for details.)

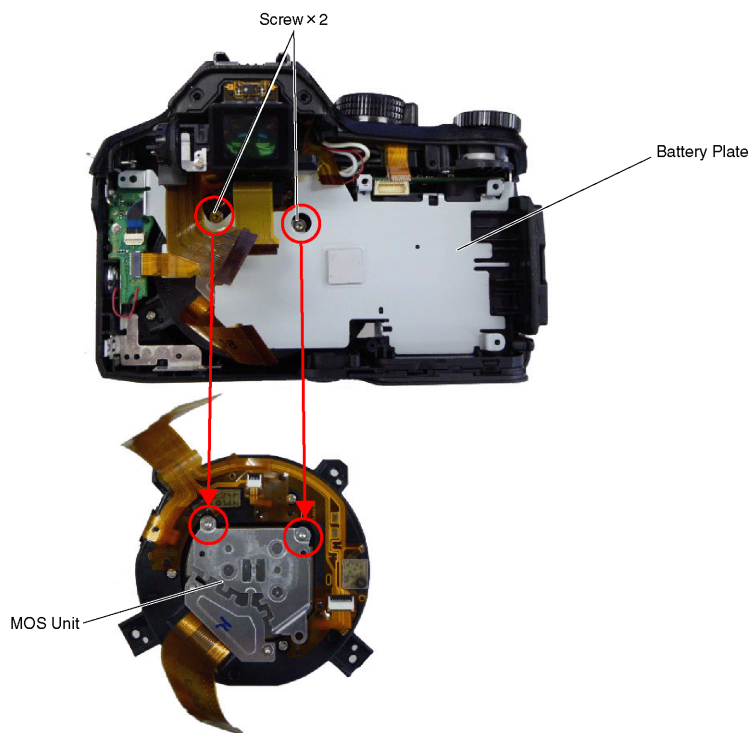

The Optical tilt adjustment can be performed with the Battery Plate attached.

3.2.2. About Venus Engine (IC6001) [Located on the Main P.C.B.]:

The Venus Engine (IC6001) consists of two IC chips (DRAM and Venus) , which are fixed together with solder.

(It's called, "Package On Package" type IC.)

When replacing, always replace in pairs. (Units of service parts: integrated (one pair) state.)

NOTE:

- During servicing, do not press down hard on the surface of IC6001.

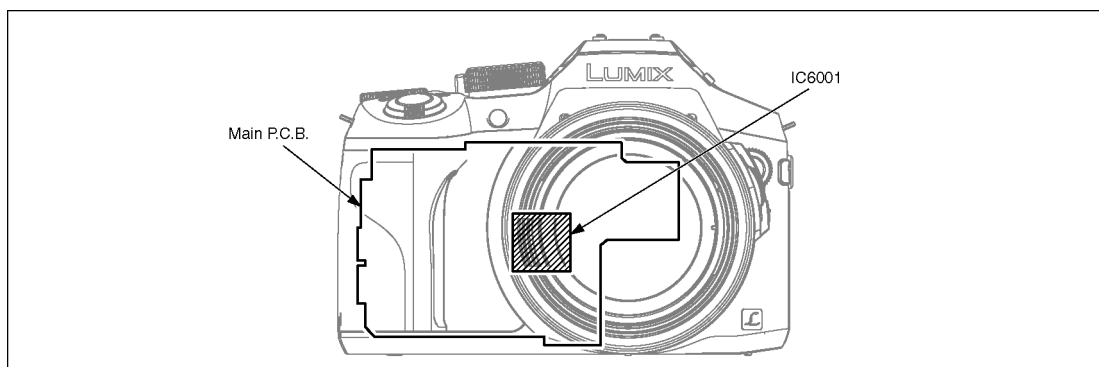

3.2.3. About Flexible Cable and Connector

Do not touch carelessly so that the foreign body should not adhere to the terminal part of flexible cable and connector.

Wipe off with a clean cloth and the cotton bud, etc. when the terminal part is dirty.

3.3. Service Notes

3.3.1. About Tilt Sensor Display

The unit has the electronic level function using G (3-axis accelerometer) sensor inside the unit.

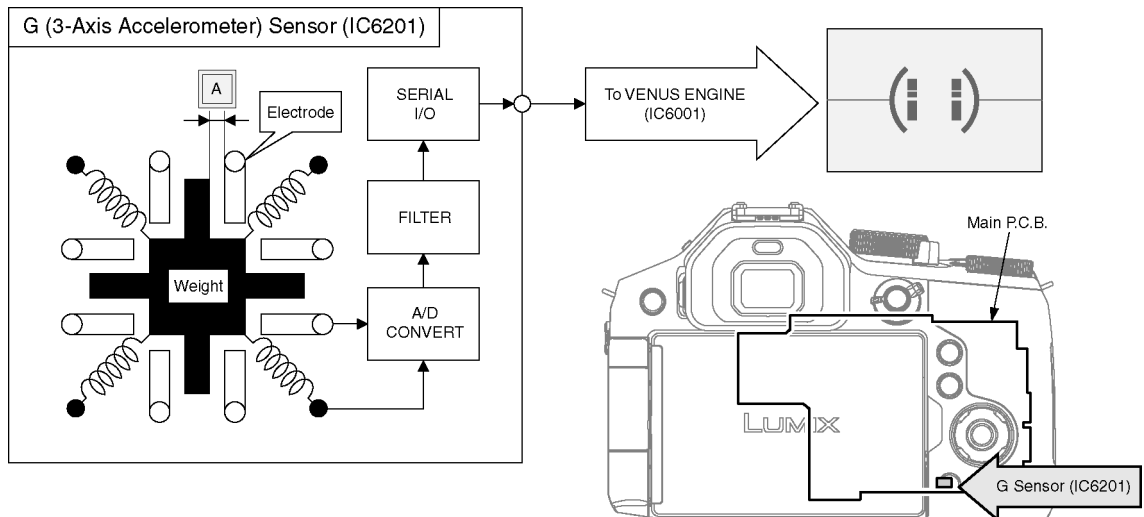

[Principal of Operation]

1. Movement of "Weight" is detected by capacitance. ----- [A]
2. Each acceleration of the X/Y/Z axis is converted into data and they are output.
3. The VENUS ENGINE converts the data into a horizontal angle and an angle of inclination, and displays them to screen.



3.3.2. About Wi-Fi Function

The page number in this chapter does not show the page number of this service manual.

<p>Operating the camera by connecting it to a smartphone/tablet (→260)</p> <ul style="list-style-type: none"> Taking pictures via a smartphone (remote recording) Playing back pictures in the camera on a smartphone Saving pictures in the camera to a smartphone Sending pictures in the camera to social networking services Writing the location information on pictures in the camera Combining motion pictures recorded with Snap Movie according to your preference on a smartphone 	
<p> Connect easily</p> <p>You can easily set up a direct connection to your smartphone without entering a password.</p>	
<p>Displaying still pictures on a TV (→273)</p>	
<p>Wireless printing (→278)</p>	
<p>Sending pictures to AV device (→279)</p> <p>Still pictures and motion pictures can be sent to AV device in the home (home AV device).</p>	
<p>Sending pictures to a PC (→280)</p>	
<p>Using WEB services (→282)</p> <p>Through "LUMIX CLUB", you can send still pictures and motion pictures to social networking services, etc. You can receive still pictures and motion pictures on a PC or a smartphone/tablet using the Cloud Sync. Service.</p>	

3.3.3. Important Notice of Servicing

This camera unit has the personal information of wireless LAN connection the customer has registered.

For the protection of private information, please erase the personal information after the completion of repair by "Initial Settings". In addition, please print out the following documents, and pass to the customer with the camera unit.

Printing Material [Leaflet for Customer]

[For The Customer]

Before using your camera please check the Wi-Fi settings.

Depending on what was serviced, the settings may have been reset to the factory defaults.

1. If the settings were reset you will need to reenter your Lumix Club login ID and password.

If you have forgotten the login ID and/or Password, please connect to the Lumix Club web site and create a new ones.

2. You may also have to reenter the settings for your local Wi-Fi network settings.

We recommend consulting the operating manual if you have any questions.

3.4. General Description About Lead Free Solder (PbF)

The lead free solder has been used in the mounting process of all electrical components on the printed circuit boards used for this equipment in considering the globally environmental conservation.

The normal solder is the alloy of tin (Sn) and lead (Pb). On the other hand, the lead free solder is the alloy mainly consists of tin (Sn), silver (Ag) and copper (Cu), and the melting point of the lead free solder is higher approx.30°C (86°F) more than that of the normal solder.

Distinction of P.C.B. Lead Free Solder being used

The letter of "PbF" is printed either foil side or components side on the P.C.B. using the lead free solder. (See right figure)	PbF
---	-----

Service caution for repair work using Lead Free Solder (PbF)

- The lead free solder has to be used when repairing the equipment for which the lead free solder is used.
(Definition: The letter of "PbF" is printed on the P.C.B. using the lead free solder.)
- To put lead free solder, it should be well molten and mixed with the original lead free solder.
- Remove the remaining lead free solder on the P.C.B. cleanly for soldering of the new IC.
- Since the melting point of the lead free solder is higher than that of the normal lead solder, it takes the longer time to melt the lead free solder.
- Use the soldering iron (more than 70W) equipped with the temperature control after setting the temperature at 350±30°C (662±86°F).

Recommended Lead Free Solder (Service Parts Route.)

- The following 3 types of lead free solder are available through the service parts route.
 - SVKZ000001 ----- (0.3mm 100g Reel)
 - SVKZ000002 ----- (0.6mm 100g Reel)
 - SVKZ000003 ----- (1.0mm 100g Reel)

Note

- * Ingredient: tin (Sn) 96.5%, silver (Ag) 3.0%, copper (Cu) 0.5%. (Flux cored)

3.5. How to Define the Model Suffix (NTSC or PAL model)









There are nine kinds of DMC-FZ300/FZ330 regardless of the colours.

- a) DMC-FZ300 (Japan domestic model), DMC-FZ300SG
- b) DMC-FZ300PP
- c) DMC-FZ300EF/EG/EP, 330EB
- d) DMC-FZ300EE
- e) DMC-FZ300GN
- f) DMC-FZ300GT
- g) DMC-FZ300GK
- h) DMC-FZ300GD
- i) DMC-FZ300GA/GC/GH

What is the difference is that the "Initial Settings" data which is stored in Flash-ROM mounted on Main P.C.B..

3.5.1. Defining methods:

To define the model suffix to be serviced, refer to the nameplate which is putted on the bottom side of the unit.

<p>a) DMC-FZ300 (Japan domestic model), DMC-FZ300SG The nameplate for these models shows the following Safety registration mark.</p> 
<p>b) DMC-FZ300PP The nameplate for this model shows the following Safety registration mark.</p> 
<p>c) DMC-FZ300EF/EG/EP, DMC-FZ330EB The nameplate for these models shows the following Safety registration mark.</p> 
<p>d) DMC-FZ300EE The nameplate for this model shows the following Safety registration mark.</p> 
<p>e) DMC-FZ300GN The nameplate for this model shows the following Safety registration mark.</p> 
<p>f) DMC-FZ300GT The nameplate for this model shows the following Safety registration mark.</p> 
<p>g) DMC-FZ300GK The nameplate for this model shows the following Safety registration mark.</p> 
<p>h) DMC-FZ300GD The nameplate for this model shows the following Safety registration mark.</p> 
<p>i) DMC-FZ300GA/GC/GH The nameplate for these models does not show any above Safety registration mark.</p>

NOTE:

After replacing the Main P.C.B., be sure to achieve adjustment.

3.5.2. Initial Settings:

After replacing the Main P.C.B. and/or Flash-ROM, make sure to perform the initial settings after achieving the adjustment by ordering the following procedure in accordance with model suffix of the unit.

1. Important Notice:

Before proceeding Initial settings, make sure to read the following CAUTION.

CAUTION :(Initial Settings)

--- After Replacing The Main P.C.B. and/or Flash-ROM ---

[Except "DMC-FZ300EF/EG/EP and FZ330" models]

- *. The model suffix can be chosen **JUST ONE TIME**.
(Effective model suffix : DMC-FZ300 "PP/EE/GA/GC/GD/GH/GK/GN/GT/SG and NONE(JAPAN)")
- *. Once one of the model suffix has been chosen, the model suffix lists will not be displayed, thus, it can not be changed.

2. Procedures:

- Precautions: Read the above "CAUTION" carefully.

- Preparation:

Attach the fully charged Battery, and insert the memory card (32MB or more).

Remove the lens cap.

- **Step 1. The Temporary Cancellation of "Initial Settings":**

Set the [Mode dial] to "[P](Program AE mode)".

While pressing [DISP.] button, "[RIGHT] of Cursor buttons" and [AF/AE LOCK] button simultaneously, turn the power on.

- **Step 2. The Cancellation of "Initial Settings":**

Press the [Playback] button in order to enter the [Playback] mode.

Press [AF/AE LOCK] button and "[UP] of Cursor buttons" simultaneously, then turn the power off.

The LCD displays the " ! " mark before the unit powers down.

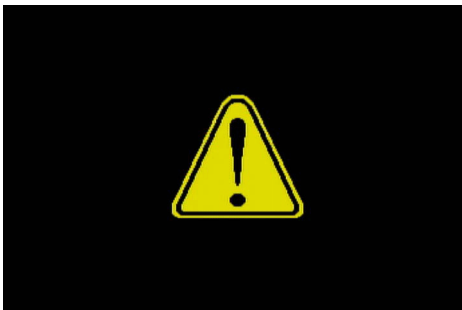

- **Step 3. Turn the Power on:**

Set the mode dial to "[P] (Program AE mode)", then turn the power on.

• **Step 4. Display the Initial Settings:**

While pressing [MENU/SET] button and "[RIGHT] of Cursor buttons" simultaneously, turn the power off.

The "Initial Settings" menu is displayed.

There are two kinds of "Initial Settings" menu form as follows:

[CASE 1. After replacing Main P.C.B. and/or Flash-ROM]

[Except "DMC-FZ300EF/EG/EP and FZ330" models: (SEP0514AA is used as a Main P.C.B.)]

When Main P.C.B. has just been replaced, 11 model suffixes are displayed as follows. (Three pages in total)

DMC-FZ300 (Japan domestic model) → FZ300 → NONE(JAPAN) 00

DMC-FZ300PP → FZ300 → PP 22

DMC-FZ300GD → FZ300 → GD 04

DMC-FZ300GC → FZ300 → GC 05

FZ300 → GT 06 → DMC-FZ300GT

FZ300 → GK 07 → DMC-FZ300GK

FZ300 → EE 0A → DMC-FZ300EE

FZ300 → GN 0B → DMC-FZ300GN

DMC-FZ300GH → FZ300 → GH 12

DMC-FZ300GA → FZ300 → GA 1B

DMC-FZ300SG → FZ300 → SG 0F

[Only "DMC-FZ300EF/EG/EP and FZ330" models: SEP0514AB is used as a Main P.C.B.]

When Main P.C.B. has just been replaced, only 5 model suffixes are displayed as follows. (Two page 5 in total)

DMC-FZ300 (No "E" model) → FZ300 → EG,E 02

(No "GC" model) → FZ300 → GC 05

DMC-FZ300EF → FZ300 → EF 08

DMC-FZ330EB → FZ330 → EB 09

FZ300 → EP 13 → DMC-FZ300EP

[CASE 2. Other than "After replacing Main P.C.B. and/or Flash-ROM"]

< Other than "FZ300EF/EG/EP and FZ330" models >

< Only "FZ300EF/EG/EP and FZ330" models >

FZ300 → PP 22

FZ300 → EG,E 02

FZ300 → EF 08

FZ330 → EB 09

FZ300 → EP 13

• **Step 5. Choose the model suffix in "Initial Settings": (Refer to "CAUTION")**

[Caution: After replacing Main P.C.B. and/or Flash-ROM]

The model suffix can be chosen, **JUST ONE TIME**.

Once one of the model suffix have been chosen, the model suffix lists will not be displayed, thus, it can not be changed.

Therefore, select the area carefully.

Select the area with pressing "[UP] / [DOWN] of Cursor buttons".

• **Step 6. Set the model suffix in "Initial Settings":**

Press the "[RIGHT] of Cursor buttons".

The only set area is displayed, and then press the "[RIGHT] of Cursor buttons" after confirmation.

(The unit is powered off automatically.)

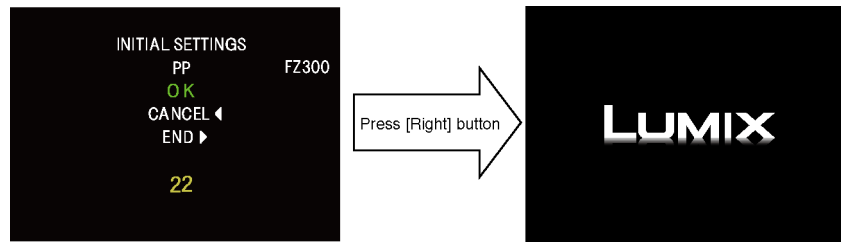

• **Step 7. Confirmation:**

Confirm the display of "PLEASE SET THE CLOCK" in concerned language when the unit is turned on again.

When the unit is connected to PC with USB cable, it is detected as removable media.

As for your reference, major default setting condition is as shown in the following table.

• **Default setting (After "Initial Settings")**

	MODEL	VIDEO OUTPUT	LANGUAGE	DATE	REMARKS
a)	DMC-FZ300 (Japan domestic model)	NTSC	Japanese	Year/Month/Date	
b)	DMC-FZ300PP	NTSC	English	Month/Date/Year	
c)	DMC-FZ300EE	PAL	Russian	Date/Month/Year	
d)	DMC-FZ300EF	PAL	English	Date/Month/Year	
e)	DMC-FZ300EG	PAL	English	Date/Month/Year	
f)	DMC-FZ300EP	PAL	English	Date/Month/Year	
g)	DMC-FZ300GA	PAL	English	Date/Month/Year	
h)	DMC-FZ300GC	PAL	English	Date/Month/Year	
i)	DMC-FZ300GD	NTSC	Korean	Year/Month/Date	
j)	DMC-FZ300GH	PAL	English	Date/Month/Year	
k)	DMC-FZ300GK	PAL	Chinese (simplified)	Year/Month/Date	
l)	DMC-FZ300GN	PAL	English	Date/Month/Year	
m)	DMC-FZ300GT	NTSC	Chinese (simplified)	Year/Month/Date	
n)	DMC-FZ300SG	PAL	English	Date/Month/Year	
o)	DMC-FZ330EB	PAL	English	Date/Month/Year	

4 Specifications

The following specification is for DMC-FZ300PP.

Some specifications may differ depending on model suffix.

Digital Camera: Information for your safety

Power Source	DC 8.4 V (≒ 8.4 V)
Power	2.1 W (When recording with monitor)
Consumption	2.4 W (When recording with viewfinder) 1.6 W (When playing back with monitor) 1.6 W (When playing back with viewfinder)

Camera effective pixels	12,100,000 pixels
Image sensor	1/2.3" MOS sensor, total pixel number 12,800,000 pixels Primary color filter
Lens	Optical 24x zoom f=4.5 mm to 108 mm (35 mm film camera equivalent: 25 mm to 600 mm) Max. Wide: F2.8 to F8.0 (When recording motion pictures: F2.8 to F11) Max. Tele: F2.8 to F8.0 (When recording motion pictures: F2.8 to F11) Filter diameter Φ 52 mm
Image Stabilizer	Optical method
Focus range	AF: 30 cm (0.98 feet) (Max. Wide) / 2 m (6.6 feet) (Max. Tele) to ∞ AF Macro / MF / Intelligent Auto / Motion picture: 1 cm (0.033 feet) (Max. Wide) / 1 m (3.3 feet) (Max. Tele) to ∞
Shutter system	Electronic shutter + Mechanical shutter
Minimum Illumination	Approx. 9 lx (when i-Low light is used, the shutter speed is 1/30th of a second)
Shutter speed	Still picture: B (Bulb) (Max. approx. 60 seconds), 60 seconds to 1/4000th of a second (When the mechanical shutter is used), 1 second to 1/16000th of a second (When the electronic shutter is used) Motion picture: 1/25th of a second to 1/16000th of a second (When [FHD/24M/24p] is set in [AVCHD], or [4K/100M/24p] is set in [MP4]), 1/2 second to 1/16000th of a second (When [M] is selected in Creative Video Mode, MF), 1/30th of a second to 1/16000th of a second (Other than the above)

Exposure (AE)	Program AE (P) / Aperture-priority AE (A) / Shutter-priority AE (S) / Manual exposure (M) / AUTO Exposure Compensation (1/3 EV steps, -3 EV to +3 EV)
[Metering Mode]	Multiple/Center weighted/Spot
Monitor	3.0" TFT LCD (3:2) (Approx. 1,040,000 dots) (field of view ratio about 100%) Touch screen
Viewfinder	0.39" OLED Live Viewfinder (4:3) (Approx. 1,440,000 dots) (field of view ratio about 100%) [Magnification approx. 3.88x, 0.7x (35 mm film camera equivalent), with 50 mm lens at infinity; -1.0 m ⁻¹] (with diopter adjustment -4.0 to +4.0 diopter)
Flash	Built-in pop up flash AUTO, AUTO/Red-Eye Reduction, Forced ON, Forced ON/Red-Eye Reduction, Slow Sync., Slow Sync./Red-Eye Reduction, Forced OFF
Microphones	Stereo
Speaker	Monaural
Recording media	SD Memory Card / SDHC Memory Card* / SDXC Memory Card* * UHS-I UHS Speed Class 3
Recording file format	
Still picture	RAW/JPEG (based on Design rule for Camera File system, based on Exif 2.3 standard / DPOF corresponding)
Motion picture	AVCHD Progressive / AVCHD / MP4
Audio compression format	AVCHD: Dolby® Digital (2 ch) MP4: AAC (2 ch)
Interface	
Digital	USB 2.0 (High Speed)
Analog video	NTSC Composite
Audio	Audio line output (Monaural)
Terminal	
[REMOTE]	Φ2.5 mm jack
[HDMI]	MicroHDMI Type D
[AV OUT/DIGITAL]	Dedicated jack (8 pin)
[MIC]	Φ3.5 mm jack

Dimensions	Approx. 131.6 mm (W) x 91.5 mm (H) x 117.1 mm (D) [5.18" (W) x 3.60" (H) x 4.61" (D)] (excluding the projection part)
Mass (weight)	With card and battery: Approx. 691 g (1.52 lb) Excluding card and battery: Approx. 640 g (1.41 lb)
Operating temperature	0 °C to 40 °C (32 °F to 104 °F)
Operating humidity	10%RH to 80%RH
Dust-proof and splash-proof	Yes
Language select	[ENGLISH] / [DEUTSCH] / [FRANÇAIS] / [ESPAÑOL] / [PORTUGUÊS] / [ITALIANO] / [繁體中文] / [日本語]

■ **Wi-Fi**

Compliance standard	IEEE 802.11b/g/n (standard wireless LAN protocol)
Frequency range used (central frequency)	2412 MHz to 2462 MHz (1 to 11 ch)
Encryption method	Wi-Fi compliant WPA™/WPA2™
Access method	Infrastructure mode

■ **Battery Charger (Panasonic DE-A79B):**

Information for your safety

Input:	~110 V to 240 V, 50/60 Hz, 0.2 A
Output:	=== 8.4 V, 0.65 A

■ **Equipment mobility:**

Movable

■ **Battery Pack (lithium-ion) (Panasonic DMW-BLC12PP):**

Information for your safety

Voltage/capacity:	7.2 V/1200 mAh
--------------------------	----------------

5 Location of Controls and Components

The following description is for DMC-FZ300PP.

Some descriptions may differ depending on model suffix.

The page number in this chapter does not show the page number of this service manual.

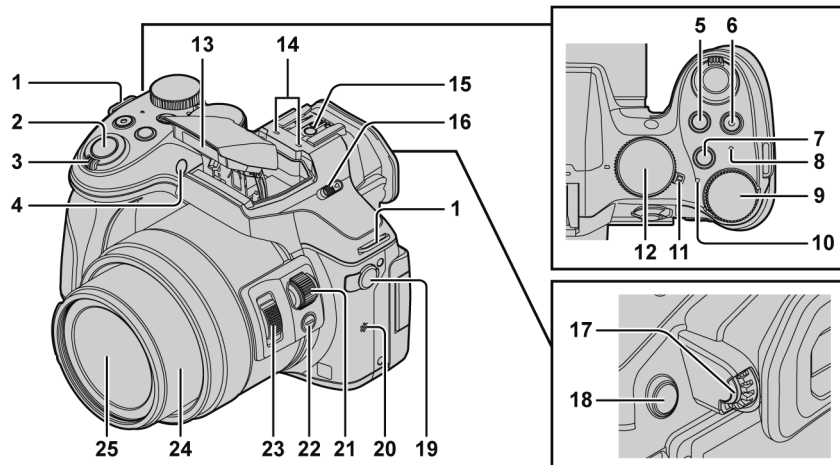

- | | |
|--|--|
| <p>1 Shoulder strap eyelet (→15)</p> <p>2 Shutter button (→20)</p> <p>3 Zoom lever (→20)</p> <p>4 Self-timer indicator / AF Assist Lamp</p> <p>5 [1/2] (Exposure Compensation) button / [Fn1] button (→26)</p> <p>6 Motion picture button (→36)</p> <p>7 [Fn2] button (→26)</p> <p>8 Wi-Fi® connection lamp</p> <p>9 Rear dial (→22)</p> <p>10 Status indicator (→19)</p> <p>11 Camera [ON/OFF] switch (→19)</p> <p>12 Mode dial (→21)
Use this to select the recording mode.</p> <p>13 Flash</p> <p>14 Stereo microphone
Be careful not to cover the microphone with your finger. Doing so may make sound difficult to record.</p> | <p>15 Hot shoe</p> <p>16 Flash open lever
The flash opens, and recording with the flash becomes possible.</p> <p>17 Diopter adjustment dial (→24)</p> <p>18 [LVF] button (→24) / [Fn4] button (→26)</p> <p>19 [MIC] socket
An external microphone (optional) can record higher quality audio than the built-in microphone.</p> <p>20 Speaker
Be careful not to cover the speaker with your finger. Doing so may make sound difficult to hear.</p> <p>21 Side dial (→22)</p> <p>22 Side button (→23)</p> <p>23 Side lever (→20)</p> <p>24 Lens barrel</p> <p>25 Lens</p> |
|--|--|

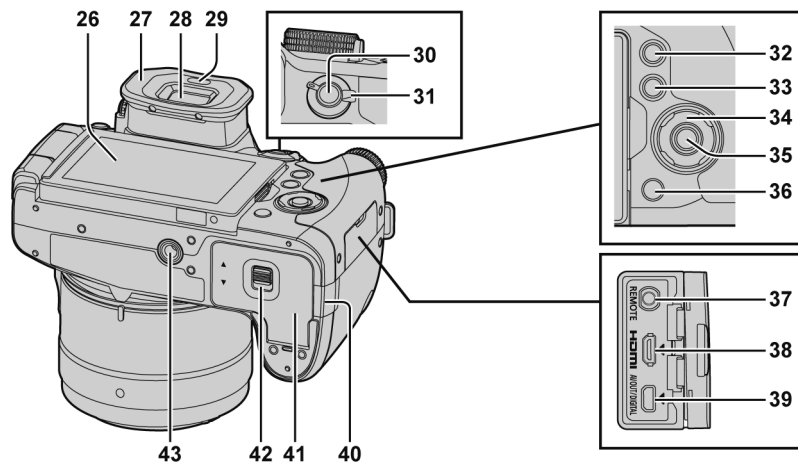

- 26** Touch screen / monitor (→19, 24, 50)
- 27** Eye cup
- 28** Viewfinder (→24)
- 29** Eye sensor (→24)
- 30** [AF/AE LOCK] button
- 31** Focus mode lever (→21)
- 32** [▶] (Playback) button (→38)
- 33** [DISP.] button
Use this to change display.
- 34** Cursor button
 - Selection of items or setting of values etc., is performed.
 - In this manual, the button that is to be used is indicated by ▲▼◀▶.

[ISO] (ISO sensitivity) (▲)
 [WB] (White Balance) (▶)
 [Drive Mode] (▼) (→32)
 [AF Mode] (◀)
- 35** [MENU/SET] button
- 36** [Q.MENU] (Delete/Cancel) button (→26, 40) / [Fn3] button (→26)
- 37** [REMOTE] socket

- 38** [HDMI] socket
- 39** [AV OUT/DIGITAL] socket
- 40** DC coupler cover (→17)
 - Always use a genuine Panasonic AC adaptor (DMW-AC10PP: optional).
 - When using an AC adaptor, ensure that the Panasonic DC coupler (DMW-DCC8: optional) and AC adaptor (DMW-AC10PP: optional) are used.
 - When using an AC adaptor, use the AC cable supplied with the AC adaptor.
- 41** Card/Battery door (→17)
- 42** Release lever (→17)
- 43** Tripod mount
Do not attach this unit to tripods that have screws with a length of 5.5 mm (0.22 inch) or more. Doing so may damage this unit or the unit may not be secured properly on the tripod.

6 Service Mode

6.1. Error Code Memory Function

1. General description

This unit is equipped with history of error code memory function, and can be memorized 16 error codes in sequence from the latest. When the error is occurred more than 16, the oldest error is overwritten in sequence.

The error code is not memorized when the power supply is shut down forcibly (i.e., when the unit is powered on by the battery, the battery is pulled out) The error code is memorized to Flash-ROM when the unit has just before powered off.

2. How to display

The error code can be displayed by ordering the following procedure:

• Preparation

Attach the fully charged Battery, and insert the memory card (32MB or more).
Remove the lens cap.

• Step 1. The Temporary Cancellation of "Initial Settings":

Set the [Mode dial] to "[P](Program AE mode)".

While pressing [DISP.] button, "[RIGHT] of Cursor buttons" and [AF/AE LOCK] button simultaneously, turn the power on.

• Step 2. Execute the Error Code Display Mode:

Press [MENU/SET] button, "[LEFT] of Cursor buttons" and [AF/AE LOCK] button simultaneously with the step 1 condition. The display is changed as shown below when the above buttons are pressed simultaneously.

Normal display → Error code display → Camera information display → Normal display →

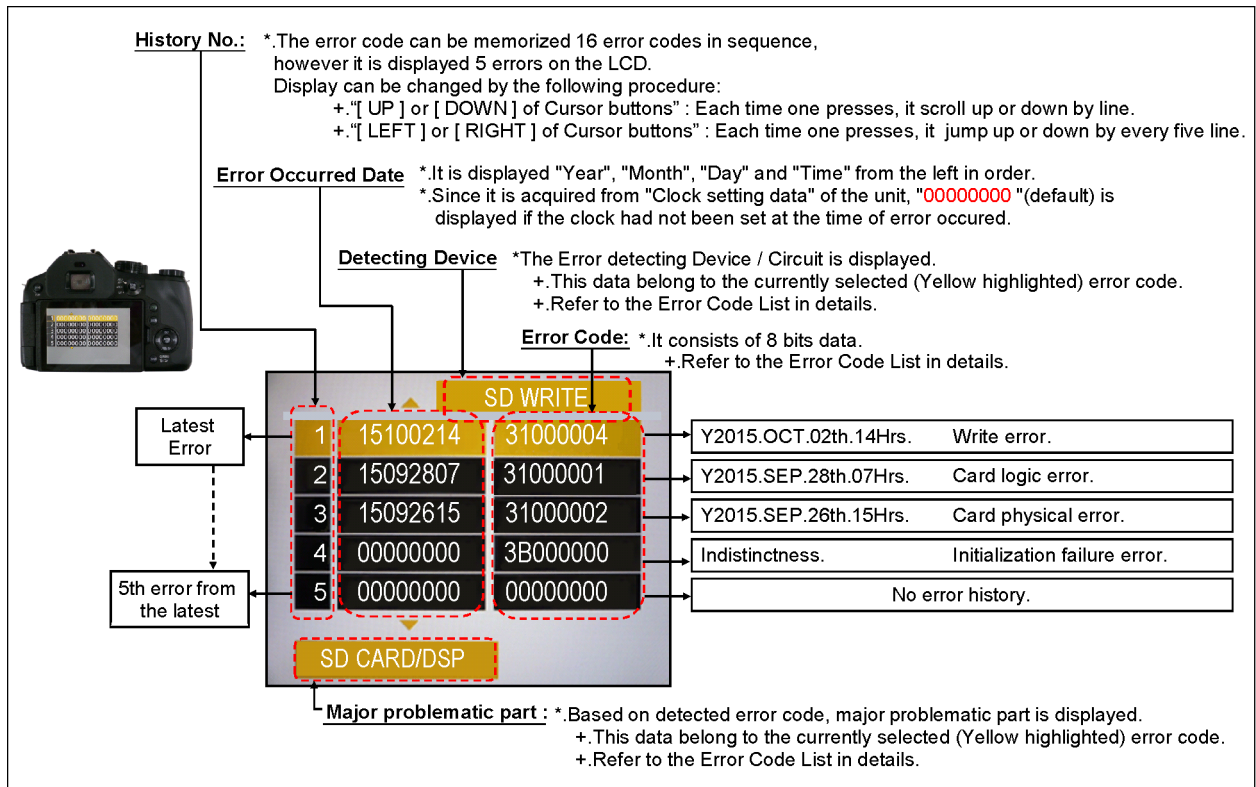

Example of Error Code Display

Error Code List

The error code consists of 8 bits data and it shows the following information.

Attribute	Main item	Sub item	Error code		Contents (Upper)	Error Indication		
			High 4 bits	Low 4 bits	Check point (Lower)	Detecting device	Part/Circuit	
LENS	Lens drive	Focus	1C*0	0?01	HP High detect error (Focus encoder always detects High, and not becomes Low)	FOCUS L	LENS FPC/ DSP	
					Mechanical lock, FP9005-(26) signal line or IC6001 (VENUS ENGINE)			
			0?02	HP Low detect error (Focus encoder always detects Low, and not becomes High)	FOCUS H			
				Mechanical lock, FP9005-(26) signal line or IC6001 (VENUS ENGINE)				
			Zoom	0?10	Collapsible barrel Low detect error (Collapsible barrel encoder always detects High.)	ZOOM L		ZOOMm/ LENSu
					Mechanical lock, FP9005-(1) signal line or IC6001 (VENUS ENGINE)			
				0?20	Collapsible barrel High detect error (Collapsible barrel encoder always detects Low.)	ZOOM H		
					Mechanical lock, FP9005-(1) signal line or IC6001 (VENUS ENGINE)			
		0?30		Zoom motor sensor error. (Initialized or Terminated)	ZOOM ENC			
				Mechanical lock, FP9005-(4), (15) signal line or IC6001 (VENUS ENGINE)				
		0?40		Zoom motor sensor error. (During monitor mode.)				
				Mechanical lock, FP9005-(4), (15) signal line or IC6001 (VENUS ENGINE)				
		0?50	Zoom motor sensor error. (During monitor mode with slow speed.)					
			Mechanical lock, FP9005-(4), (15) signal line or IC6001 (VENUS ENGINE)					
		0?60	Detection of zoom misregistration by impact such as falls. Lens Unit	(No indication)	(No indication)			
		OIS	1000	PSD (X) error. Hall element (X axis) position detect error in OIS unit. OIS Unit	OIS X	LENSu NG		
				2000	PSD (Y) error. Hall element (Y axis) position detect error in OIS unit. OIS Unit		OIS Y	
			3000	GYRO (X) error. Gyro (IC7101 : X axis) detect error on Main P.C.B. IC7101 (Gyro element) or IC6001 (VENUS ENGINE)	GYRO X	GYRO NG		
				4000	GYRO (Y) error. Gyro (IC7101 : Y axis) detect error on Main P.C.B. IC7101 (Gyro element) or IC6001 (VENUS ENGINE)		GYRO Y	
			5000	GYRO (R) error, Gyro (IC7101 : R axis) detect error on Main P.C.B. IC7101 (Gyro element) or IC6001 (VENUS ENGINE)	GYRO R			
			6000	Drive voltage (X) error. LENS Unit, LENS flex breaks, IC6001(VENUS ENGINE) AD value error, etc.	OISX REF	LENSu/LENS FPC		
				7000	Drive voltage (Y) error. LENS Unit, LENS flex breaks, IC6001(VENUS ENGINE) AD value error, etc.		OISY REF	
			8000	OIS GYRO - Digital communication error. IC7101 (Gyro element) or IC6001 (VENUS ENGINE)	(No indication)	(No indication)		
		Lens	1C*1	0000	Power ON time out error. Lens drive system	LENS DRV	LENSu	
					1C*2			0000

Attribute	Main item	Sub item	Error code		Contents (Upper)	Error Indication	
			High 4 bits	Low 4 bits	Check point (Lower)	Detecting device	Part/Circuit
	Adj.History	OIS	1D*0	2000	OIS adj. Yaw direction amplitude error (small)	OIS ADJ	OIS ADJ
				3000	OIS adj. Pitch direction amplitude error (small)		
				4000	OIS adj. Yaw direction amplitude error (large)		
				5000	OIS adj. Pitch direction amplitude error (large)		
				8000	OIS adj. Yaw direction off set error		
				9000	OIS adj. Pitch direction off set error		
				A000	OIS adj. Yaw direction gain error		
				B000	OIS adj. Pitch direction gain error		
				C000	OIS adj. Yaw direction position sensor error		
				D000	OIS adj. Pitch direction position sensor error		
				E000	OIS adj. other error		
HARD	FLASH	Flash	28*0	0000	Flash charging capacitor did not been fully charged within 20 seconds	STRB CHG	FLASH P.C.B./FPC
				FLASH ROM	Data Area	2B*0	0001
	0002	IC6003 (Flash-ROM) data writing error is detected when the unit turns OFF	FROM WR				FROM
	Program Area	0005	Firmware update error			(No indication)	(No indication)
	SOFT	CPU	Reset	30*0	0001 0007	System error (NMI reset)	NMI RST
Recording Media					Memory card	31*0	0002
		0004	Memory card writing error Check the memory card. It might be damage one.	SD WRITE			
Recording		Motion Image Recording	3F*0	0001	File time out error in recording motion image	(No indication)	(No indication)
				0002	File data cue send error in recording motion image		
Wi-Fi			3211	**02 **0C	Wi-Fi related errors: *Generally, above are unable to specified the, which cannot be used for malfunction diagnosis.		

Important notice about "Error Code List"

1) About "*" indication:

The third digit from the left is different as follows.

- In case of 0 (example: 1801000)

When the third digit from the left shows "0", this error occurred under the condition of Initial Settings has been completed.

It means that this error is occurred basically at user side.

- In case of 8 (example: 18801000)

When the third digit from the left shows "8", this error occurred under the condition of Initial Settings has been released. (Example; Factory assembling-line before unit shipment, Service mode etc.)

It means that this error is occurred at service side.

2) About "?" indication: ("18*0 0?01" to "18*0 0?60"):

The third digit from the right shows one of the hexadecimal ("0" to "F") character.

• Step 3. How to exit from Error Code display mode:

Simply, turn the power off. (Since Error code display mode is executed under the condition of temporary cancellation of "Initial Settings", it wake up with normal condition when turn off the power.)

NOTE:

The error code can not be initialized.

7 Troubleshooting Guide

7.1. Wi-Fi Module (Flash P.C.B. Unit)

7.1.1. How to Remove Wi-Fi Password Protection

To prevent incorrect operation or use of the Wi-Fi function by a third party and to protect saved personal information, this unit protects the Wi-Fi function with a password.

It is unable to service with password locked condition. When accepting for repair, the unit has been set the Wi-Fi password by customer, run the [Reset Wi-Fi Settings] for removing Wi-Fi password, then check the operation.

[Reset Procedure of Wi-Fi Settings]

- 1) Press the [MENU/SET] button, and select the [SETUP] mode by Cursor buttons, then press the [MENU/SET] button.
- 2) Select [Reset Wi-Fi Settings] by Cursor buttons, then press the [MENU/SET] button.
- 3) Select [YES] and press the [MENU/SET] button.

(The [Reset Wi-Fi Settings] performs not only resetting Wi-Fi Password but also resetting other all Wi-Fi Settings.)

7.1.2. Checking of Trouble Caused by Wi-Fi Module or Not

The Wi-Fi module works properly if the wireless access point (broadband router) name (SSID) in use is displayed on a screen of [Manual Connection].

(Primary Confirmation)

Confirm that the wireless access point (broadband router) works properly.

(Procedure)









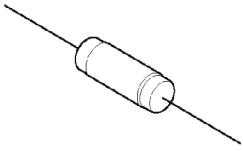
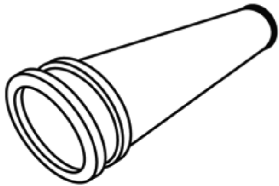
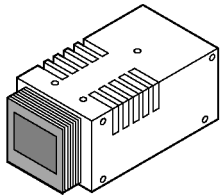

- 1) Press [Wi-Fi] button.
- 2) Select [New Connection] in [Wi-Fi] menu.
- 3) Select optional function in [select a function] menu, then select [Direct] in [Select connection method] menu.
- 4) Select [Manual Connection] in [Select connection method] menu.
- 5) The Wi-Fi module works properly if the wireless access point (broadband router) name (SSID) in use is displayed.

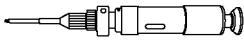
*Change the Flash P.C.B. Unit, when the above checking detected the abnormal of Wi-Fi module.

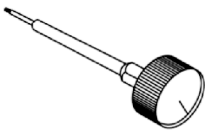
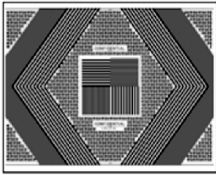
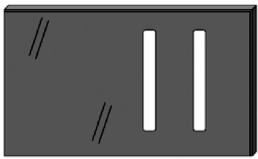
8 Service Fixture & Tools

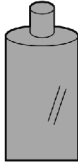
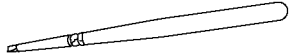
8.1. Service Fixture and Tools

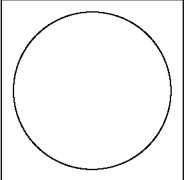
The following Service Fixture and tools are used for checking and servicing this unit.

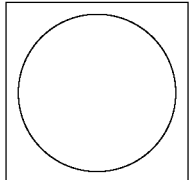
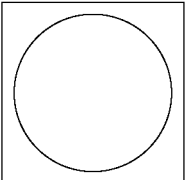
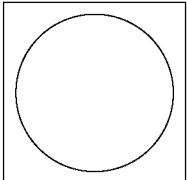
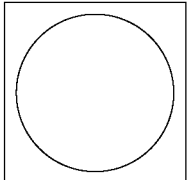
Resistor for Discharging (1k Ω /5W) ERG5SJ102	COLLIMATOR (built-in Focus Chart) RFKZ0422	LIGHT BOX (with DC Cable) RFKZ0523	
 * An equivalent type of resistor may be used.			
Lens Cleaning Kit (BK) VFK1900BK	Torque Driver RFKZ0542	Diffuser RFKZ0591	
 * Only supplied as 10 set/box.			
Driver (for Optical Axis Adjustment) RFKZ0569	Optical Axis Adjustment Chart RFKZ0570	Camera stand RFKZ0333J	
 * T4 Torx type			
Grease (for Lens) RFKZ0472	Screw locking glue RFKZ0573	Silicon chips RFKZ0478	
			
Gray Card RFKZ0506	ND Filter (ND0.3) RFKZ0513	ND Filter (ND0.6) VFK1164ND06	ND Filter (ND0.9) VFK1164ND09
			
CC Filter (CC-C7.5) RFKZ0511	CC Filter (CC-Y10) RFKZ0512	LB Filter (LBB2) RFKZ0520	LB Filter (LBB8) RFKZ0521
			

8.2. When Replacing the Main P.C.B.

After replacing the Main P.C.B., be sure to achieve adjustment.

8.3. Service Position

This Service Position is used for checking and replacing parts. Use the following Extension cables for servicing.

Table S1 Extension Cable List

No.	Parts No.	Connection	Form
1	RFKZ0343	PS9001(MAIN) ↔ PP8001(FLASH)	30pin B to B
2	VFK2024	FP9005(MAIN) ↔ LENS UNIT	51pin / 0.3 FFC
3	RFKZ0392	FP9007(MAIN) ↔ REAR OPERATION UNIT	14pin / 0.5 FFC
4	RFKZ0626	FP9002(MAIN) ↔ TOP CASE UNIT	21pin / 0.3 FFC
5	RFKZ0477	FP9003(MAIN) ↔ HINGE FPC UNIT-FP4101(LCD IF)	45pin / 0.3 FFC
6	VFK1716	FP9006(MAIN) ↔ MULTI FPC UNIT-TOP CASE UNIT	25pin / 0.3 FFC
7	RFKZ0631	FP9004(MAIN) ↔ JOINT FPC-FP9301(MIC JACK)/ SIDE OPERATION UNIT/ FRONT CASE UNIT	16pin / 0.4 FFC

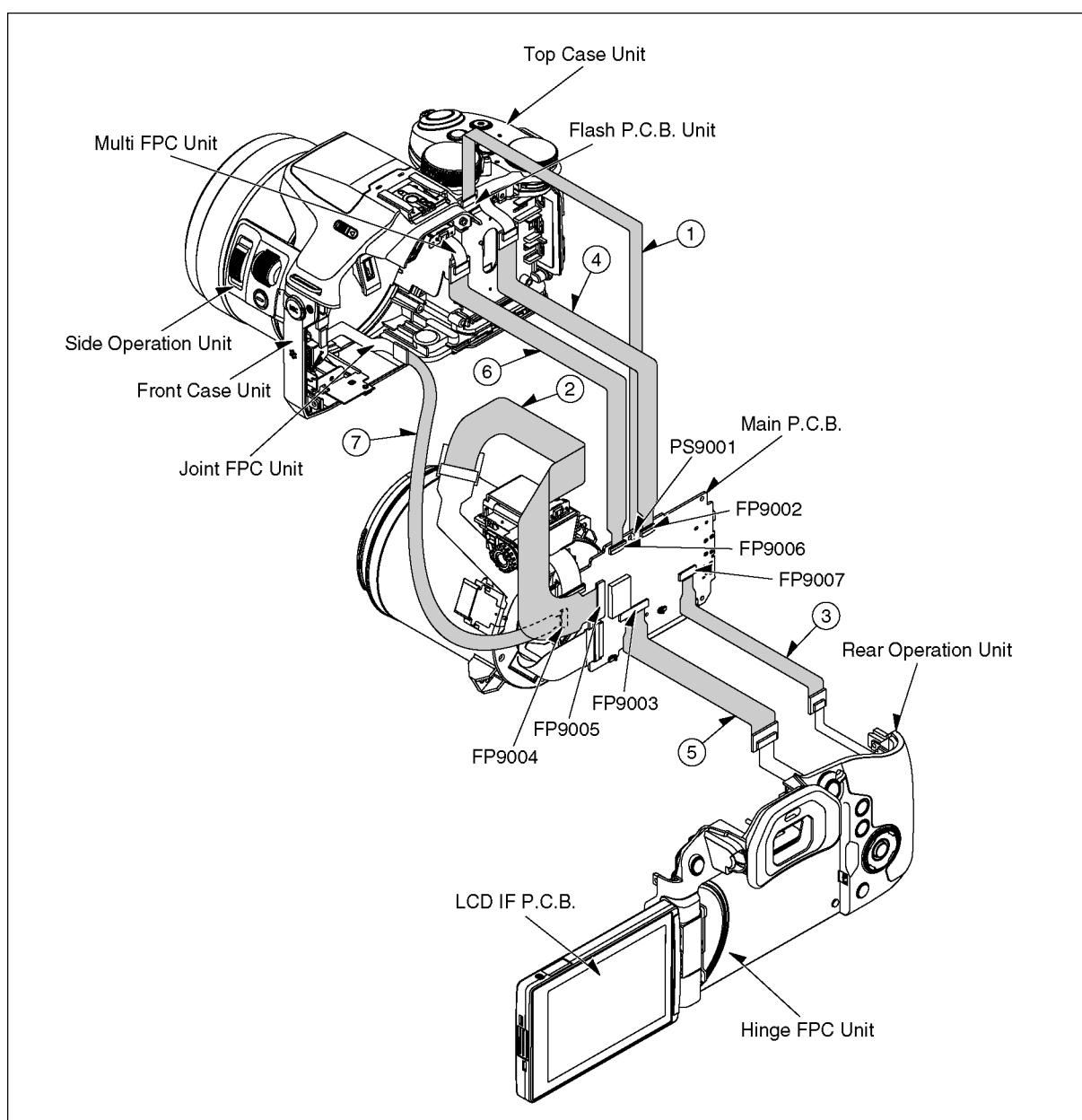

CAUTION (When servicing Flash P.C.B. Unit)

1. Be sure to discharge the E.Capacitor on Flash P.C.B. Unit.
Refer to "How to Discharge the E.Capacitor on Flash P.C.B. Unit."
The E.Capacitor voltage is not lowered soon even if the AC Cord is unplugged or the battery is removed.
2. Be careful of the high voltage circuit on Flash P.C.B. Unit.
3. DO NOT allow other parts to touch the high voltage circuit on Flash P.C.B. Unit

9 Disassembly and Assembly Instructions

9.1. Disassembly Flow Chart

This is a disassembling chart.

When assembling, perform this chart conversely.

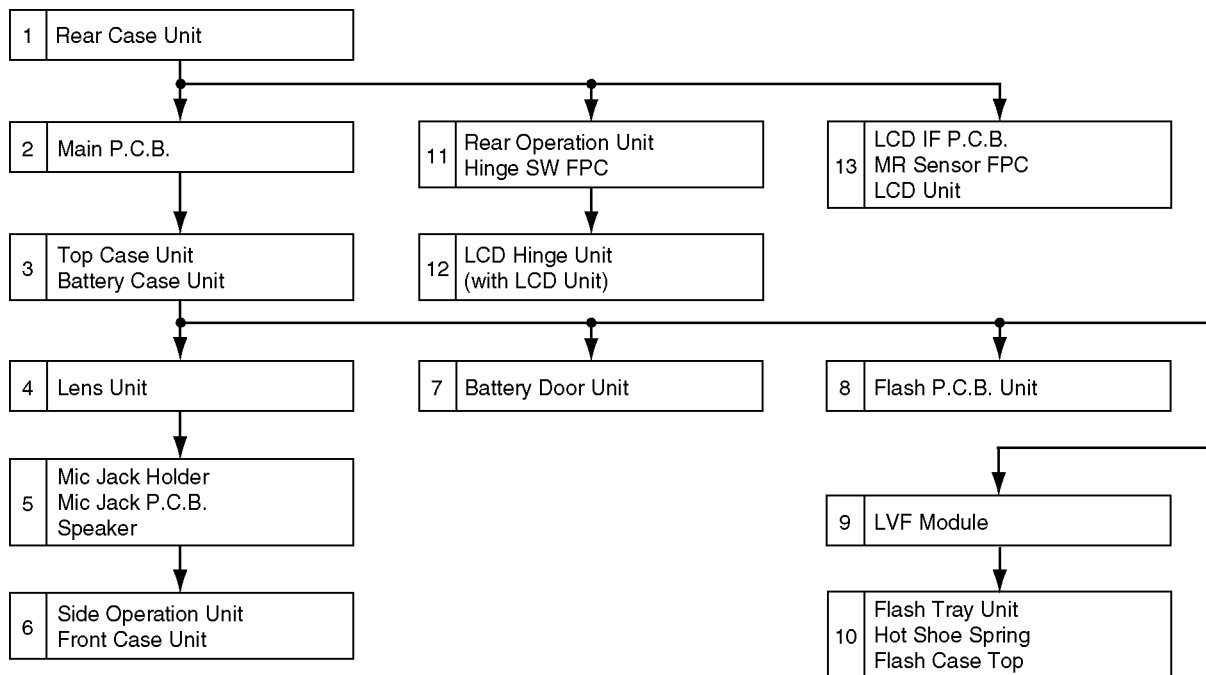

9.2. P.C.B. Location

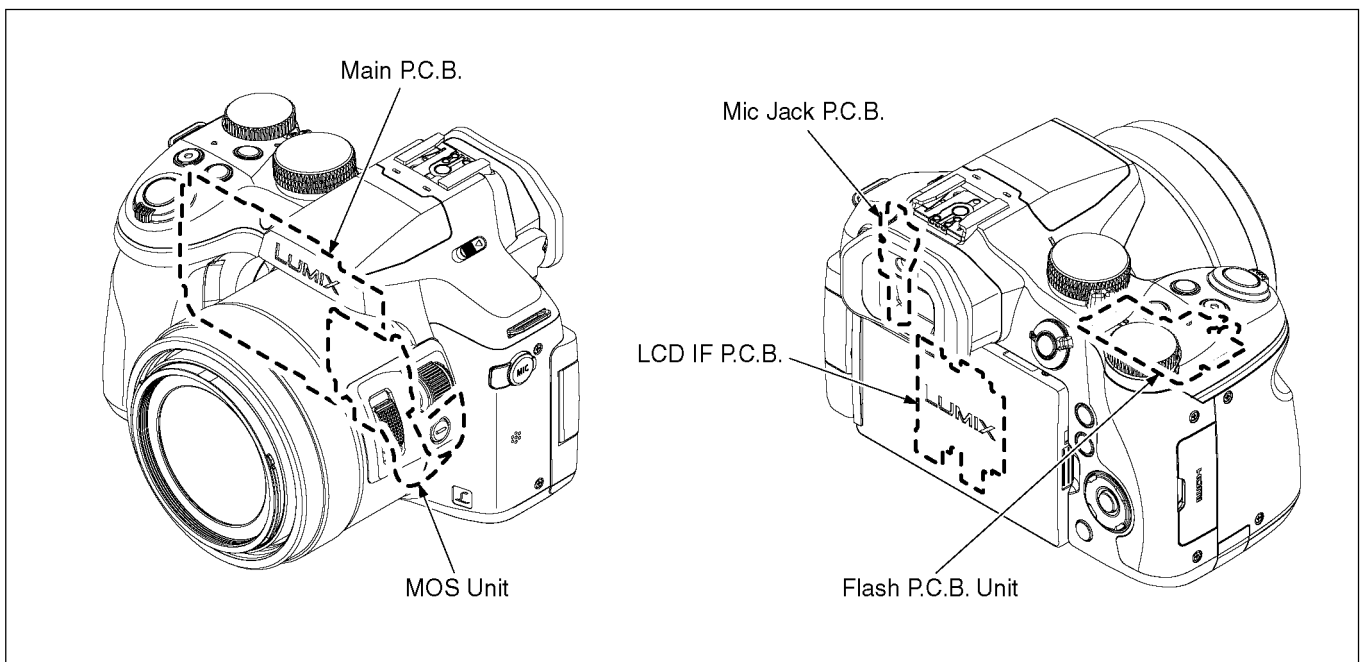

9.3. Disassembly Procedure

No.	Item	Fig.	Removal	
1	Rear Case Unit	(Fig. D1)	Memory Card	
			Battery	
			Screw (A) × 3	
			Screw (B) × 3	
		(Fig. D2)	Screw (C) × 3	
			Locking tab (A) × 2	
			Locking tab (B) × 2	
			Locking tab (C) × 2	
			Locking tab (D) × 2	
		(Fig. D3)	Eye Cap Unit	
			Screw (D) × 2	
		(Fig. D4)	When Installing	
			Locking tab × 3	
			Rear Grip	
(Fig. D5)	Screw (E) × 2			
	FP9003 (Flex)			
	FP9007 (Flex)			
	Rear Case Unit			
2	Main P.C.B.	(Fig. D6)	Screw (F) × 4	
			FP9001 (Flex)	
			FP9002 (Flex)	
			FP9004 (Flex)	
			FP9005 (Flex)	
			FP9006 (Flex)	
			FP9009 (Flex)	
			PS9001 (Connector)	
		Main P.C.B.		
		(Fig. D7)	When Replacing	
3	Top Case Unit Battery Case Unit	(Fig. D8)	Screw (G) × 1	
			Locking tab × 2	
			Battery Plate (with Thermal Sheet C)	
		(Fig. D9)	Screw (H) × 1	
			Screw (I) × 1	
			Screw (J) × 1	
		(Fig. D10)	Front Grip	
			Screw (K) × 4	
			Screw (L) × 2	
			Top Case Unit	
(Fig. D11)	Battery Case Unit			
	When Installong			
(Fig. D12)				
4	Lens Unit	(Fig. D13)	Screw (M) × 4	
			Lens Unit	
5	Mic Jack Holder, Mic Jack P.C.B., Speaker	(Fig. D14)	Screw (N) × 1	
			FP9302 (Flex)	
			Convex × 1	
			Mic Jack Holder	
			Mic Jack P.C.B.	
			Solder (2 points)	
			Speaker	
6	Side Operation Unit Front Case Unit	(Fig. D15)	Screw (O) × 2	
			Locking tab × 2	
			Side Frame	
			Screw (P) × 2	
			Lens Ring	
			Convex × 4	
			Side Operation Unit	
			Front Case Unit	
			(Fig. D16)	Screw (Q) × 2
				Battery Door Unit

No.	Item	Fig.	Removal
8	Flash P.C.B. Unit	(Fig. D17)	Convex × 1
		(Fig. D18)	Locking tab × 1
			Screw (R) × 1
			Locking tab (A) × 3
		(Fig. D19)	Condenser Cover
			Locking tab (B) × 2
Solder (4 points)			
9	LVF Module	(Fig. D20)	Flash P.C.B. Unit
			Convex (A) × 2
			Hooking part (A) × 2
			Multi FPC Unit
			Screw (S) × 2
			Convex (B) × 2
			Locking tab × 2
			Hooking part (B) × 2
			LVF Cover Unit
			LVF Unit
			Heat Radiation Pad
LVF Module			
10	Flash Tray Unit, Shoe Spring, Flash Case Top	(Fig. D21)	Screw (T) × 3
			Flash Tray Unit
			Shoe Spring
			Screw (U) × 2
			Locking tab × 2
11	Rear Operation Unit Hinge SW FPC	(Fig. D22)	Flash Case Top
			Screw (V) × 2
			Locking tab × 1
			Hinge Arm Cover
			Screw (W) × 12
			Convex (A) × 6
			Rear Plate Unit
			Convex (B) × 5
			Rear Operation Unit
			Solder (6 points)
Convex (C) × 8			
Hinge SW FPC			
12	LCD Hinge Unit (with LCD Unit)	(Fig. D23)	Convex × 4
			Screw (X) × 2
			Hinge Earth
			Spacer
			Hinge Fix Cover
			Hinge Cushion 4
			LCD Hinge Unit (with LCD Unit)
13	LCD IF P.C.B., MR Sensor FPC, LCD Unit	(Fig. D24)	Screw (Y) × 2
			Screw (Z) × 2
			Locking tab × 8
		(Fig. D25)	LCD Case Bottom
			FP4101 (Flex)
			FP4102 (Flex)
			FP4103 (Flex)
			FP4104 (Flex)
			Locking tab × 1
			LCD IF P.C.B.
		(Fig. D26)	Convex × 2
			MR Sensor FPC
		(Fig. D27)	LCD Bezel Sheet
LCD Bezel			
LCD Earth Plate × 2			
LCD Unit			
(Fig. D28)	When Installing		

9.3.1. Removal of the Rear Case Unit

NOTE:

- When servicing and reassembling, remove the memory card and battery from the unit.
Install the lens cap to prevent garbage and dust except when it is necessary.

- Memory Card
- Battery
- Screw (A) × 3
- Screw (B) × 3
- Screw (C) × 2

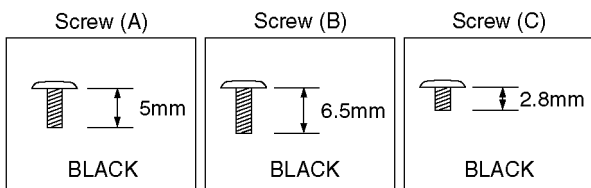
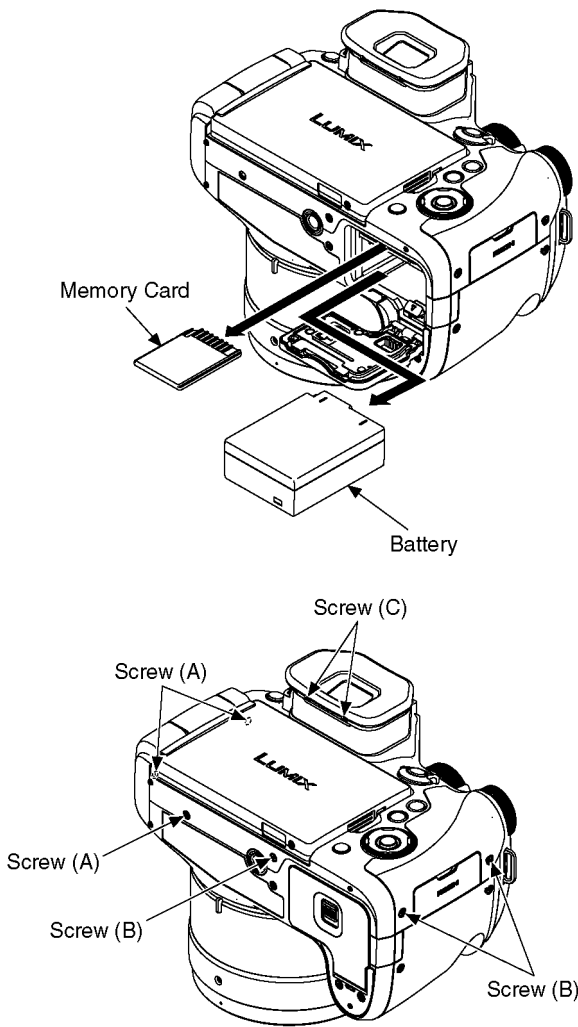

(Fig. D1)

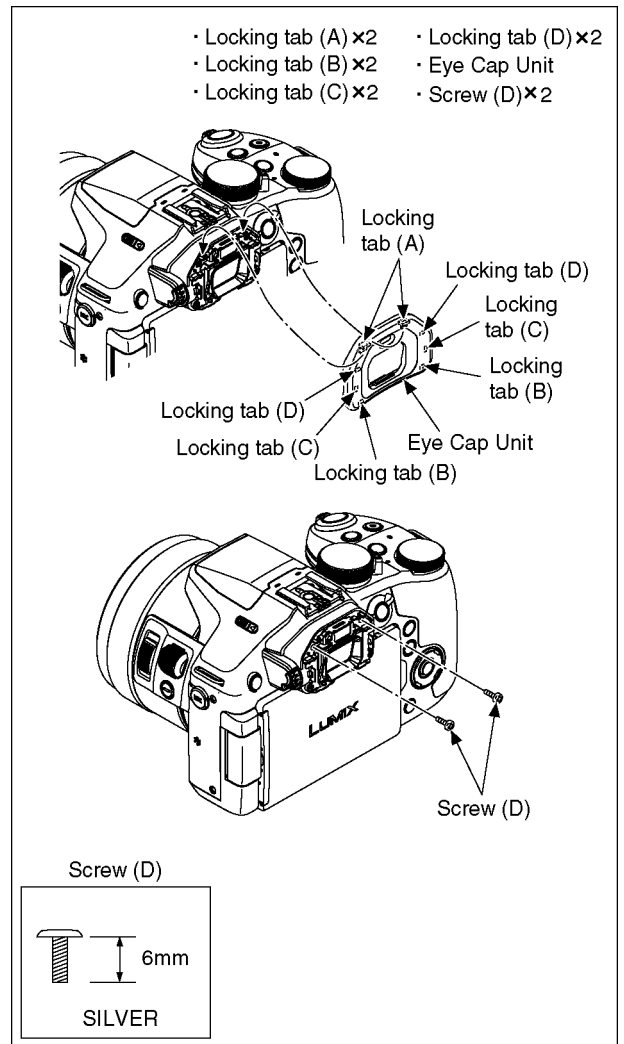

(Fig. D2)

NOTE: (When Installing)

• According to the following procedure, attach the Eye Cap Unit so as not to form any clearance among Eye Cap Unit, Rear Case Unit and Top Case Unit.

1. Push in the Eye Cap Unit in the arrow direction (1), and hook the Locking tab (1) on the Hooking part.
2. Push in the Eye Cap Unit in the arrow direction (2), and hook the Locking tab (2) on the Hooking part.
3. Push in the Eye Cap Unit in the arrow direction (3), and hook the Locking tab (3) on the Hooking part.
4. Release your finger once. Then, push in the Eye Cap Unit in the arrow direction (4), and hook the Locking tab (4) on the Hooking part.

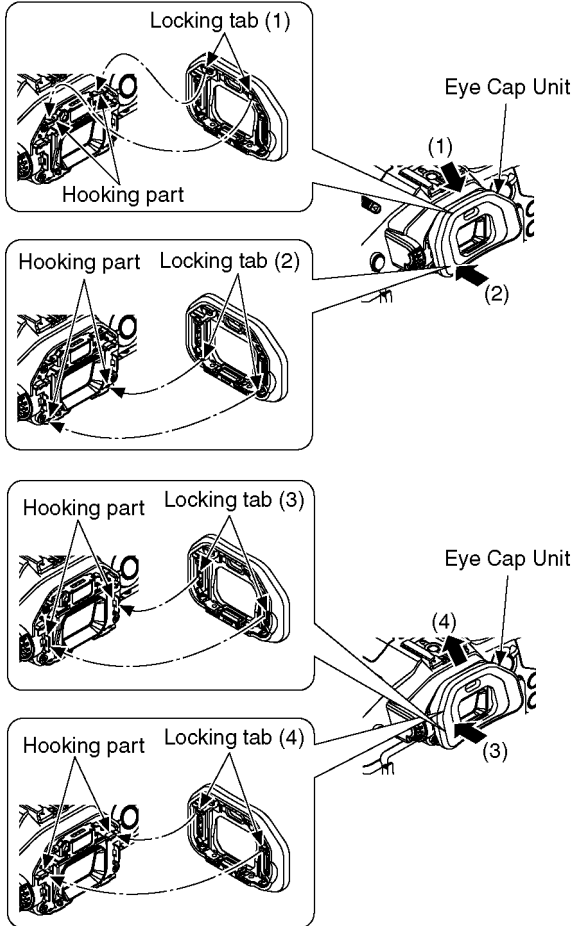

※ Make sure there is no clearance.

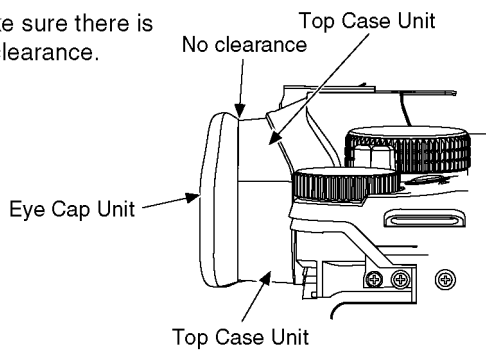

(Fig. D3)

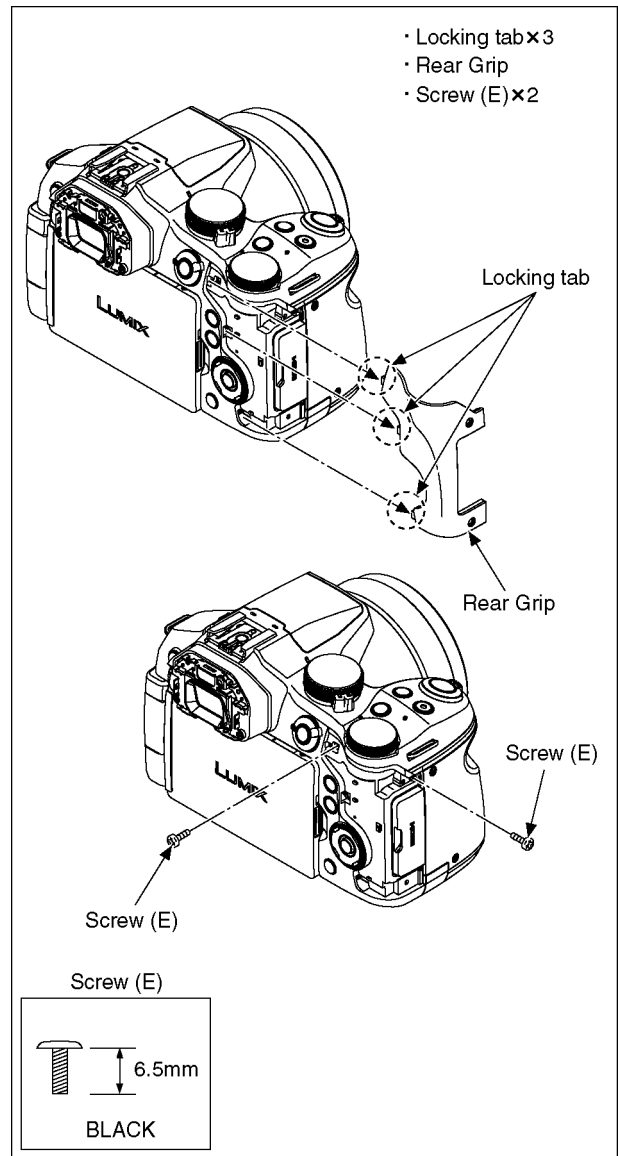

(Fig. D4)

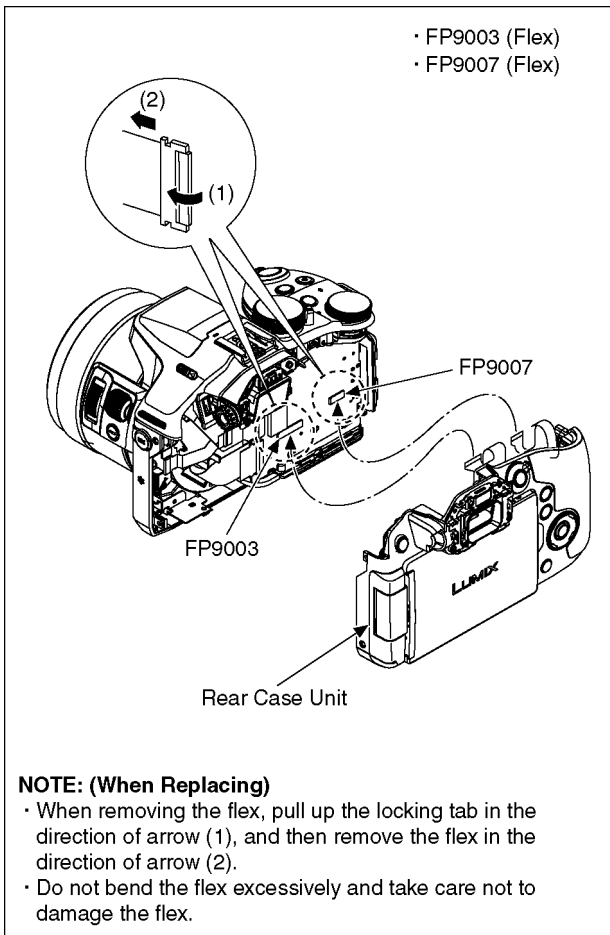

(Fig. D5)

9.3.2. Removal of the Main P.C.B.

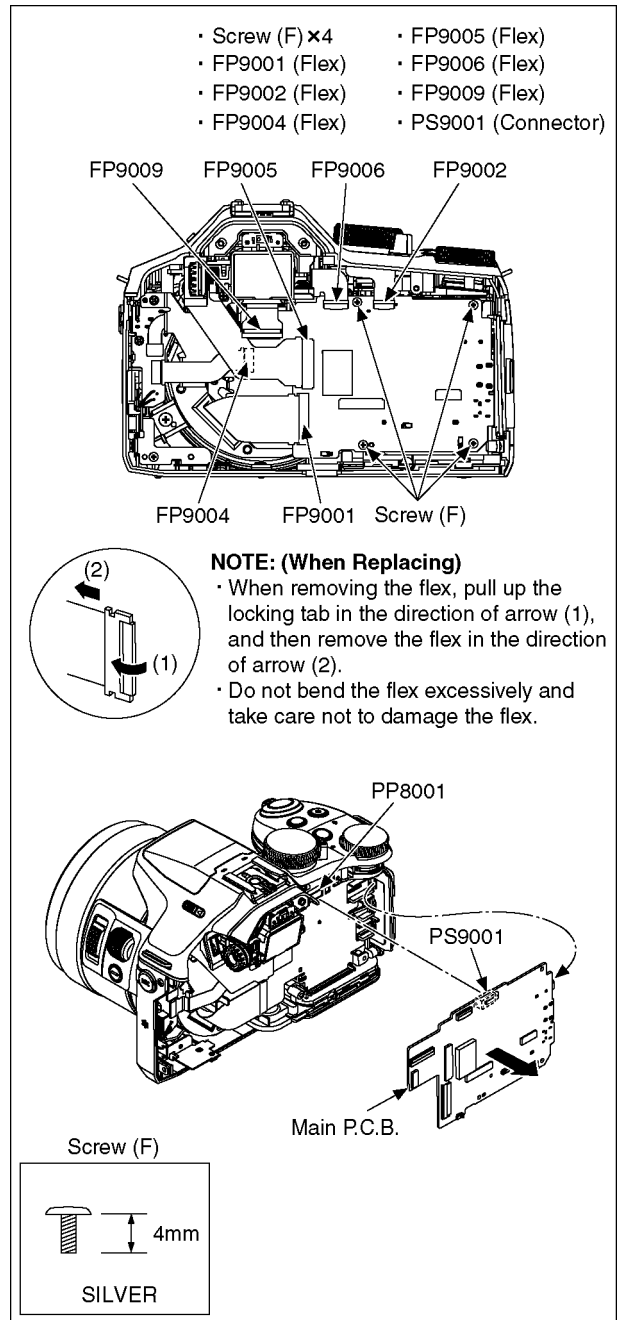

(Fig. D6)

9.3.3. Removal of the Top Case Unit and Battery Case Unit

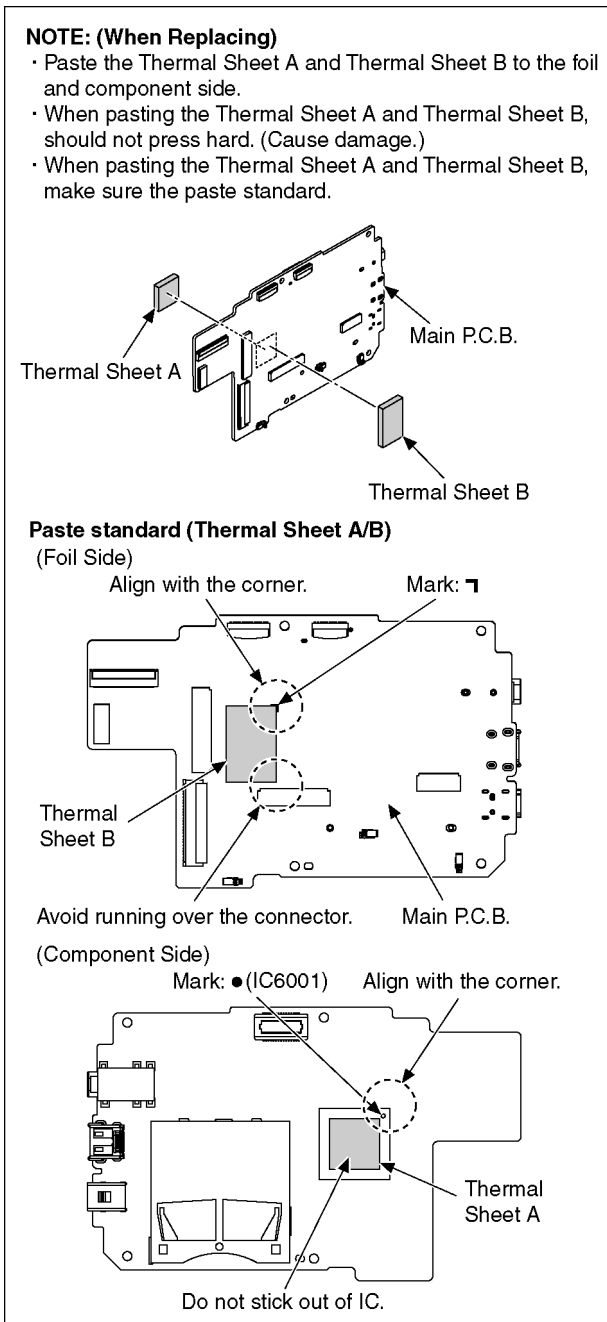

(Fig. D7)

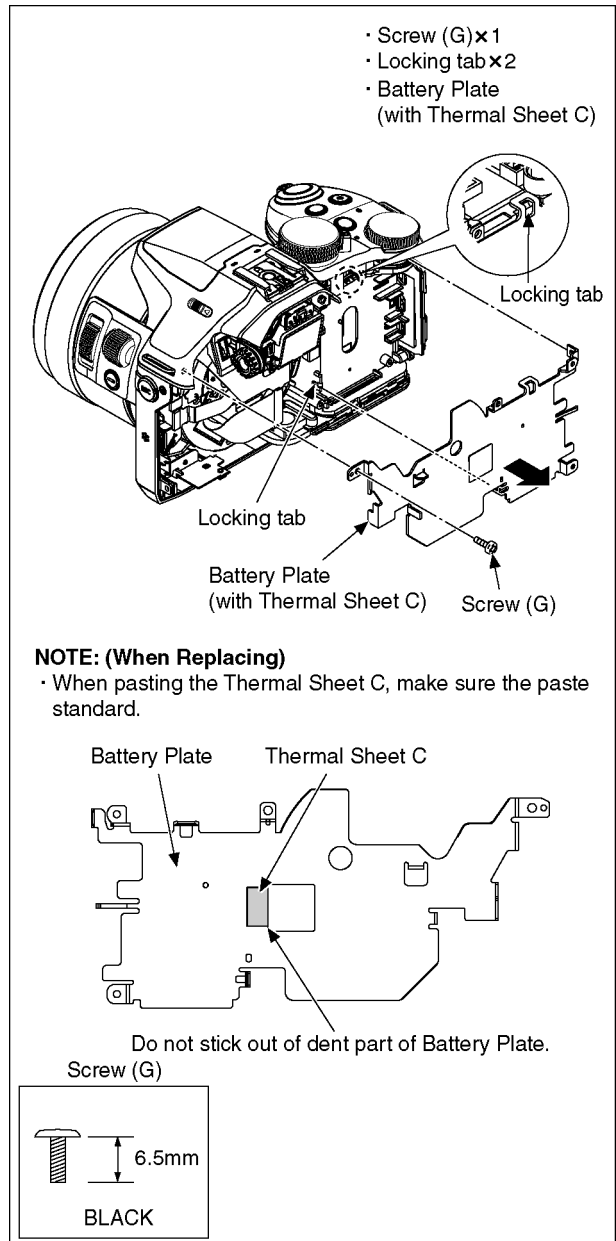

(Fig. D8)

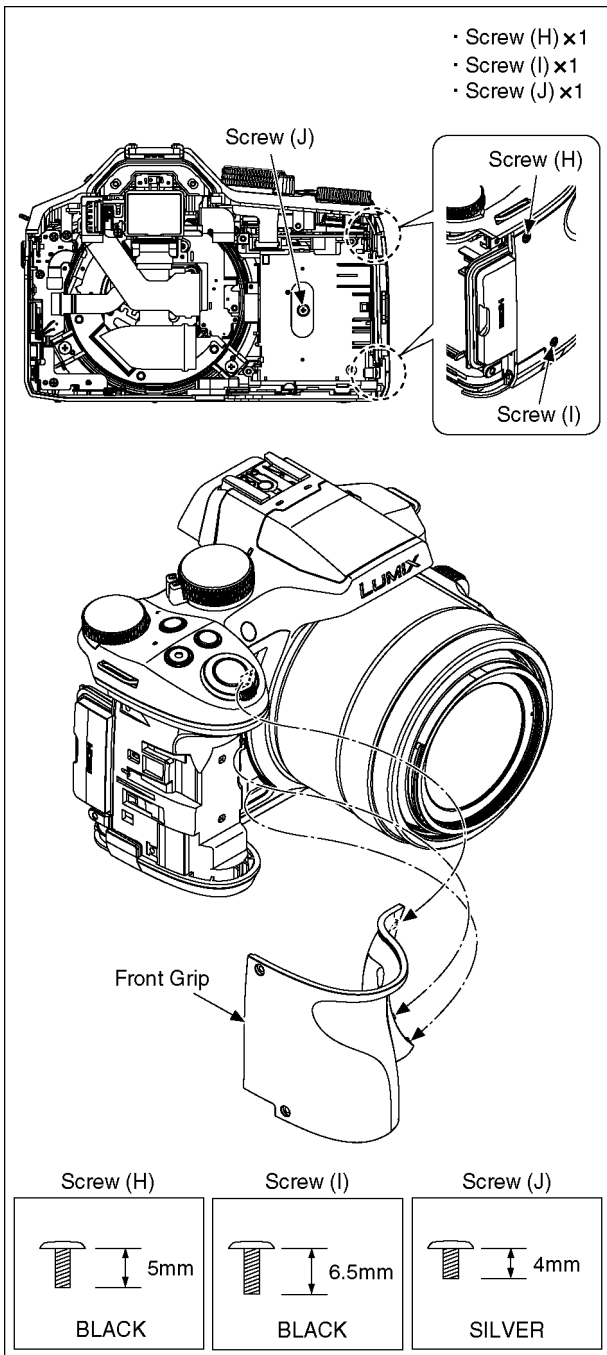

(Fig. D9)

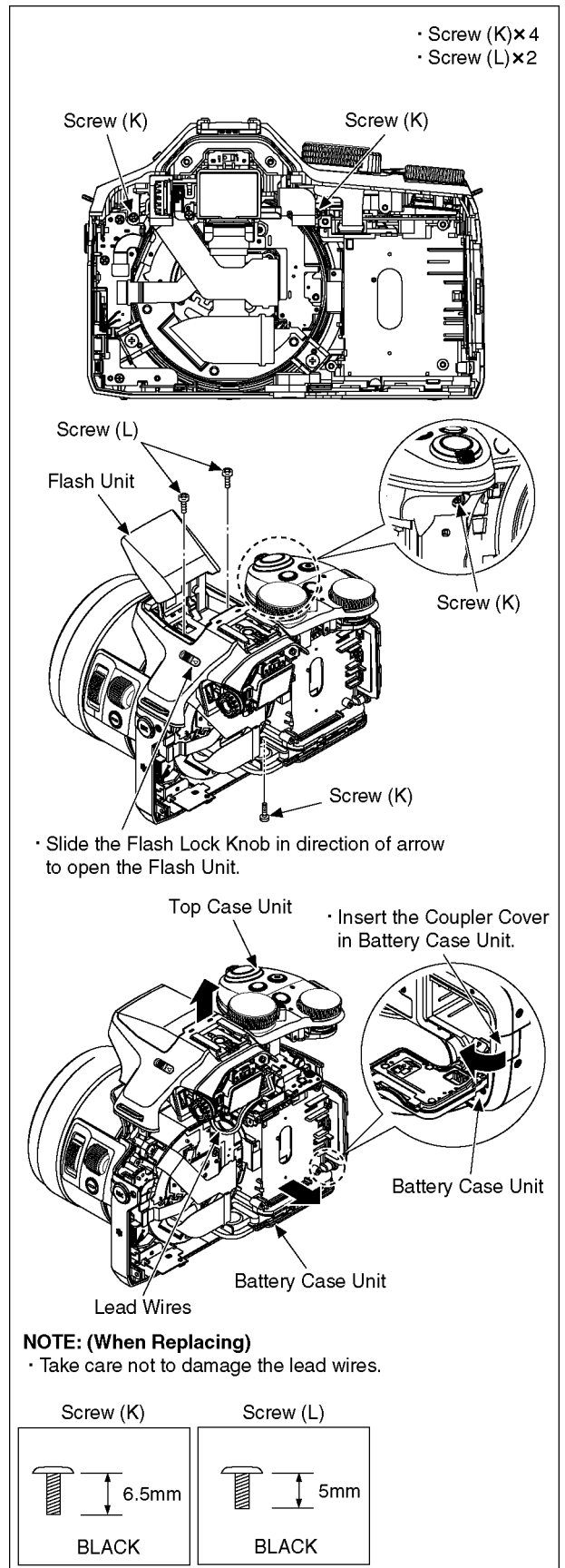

(Fig. D10)

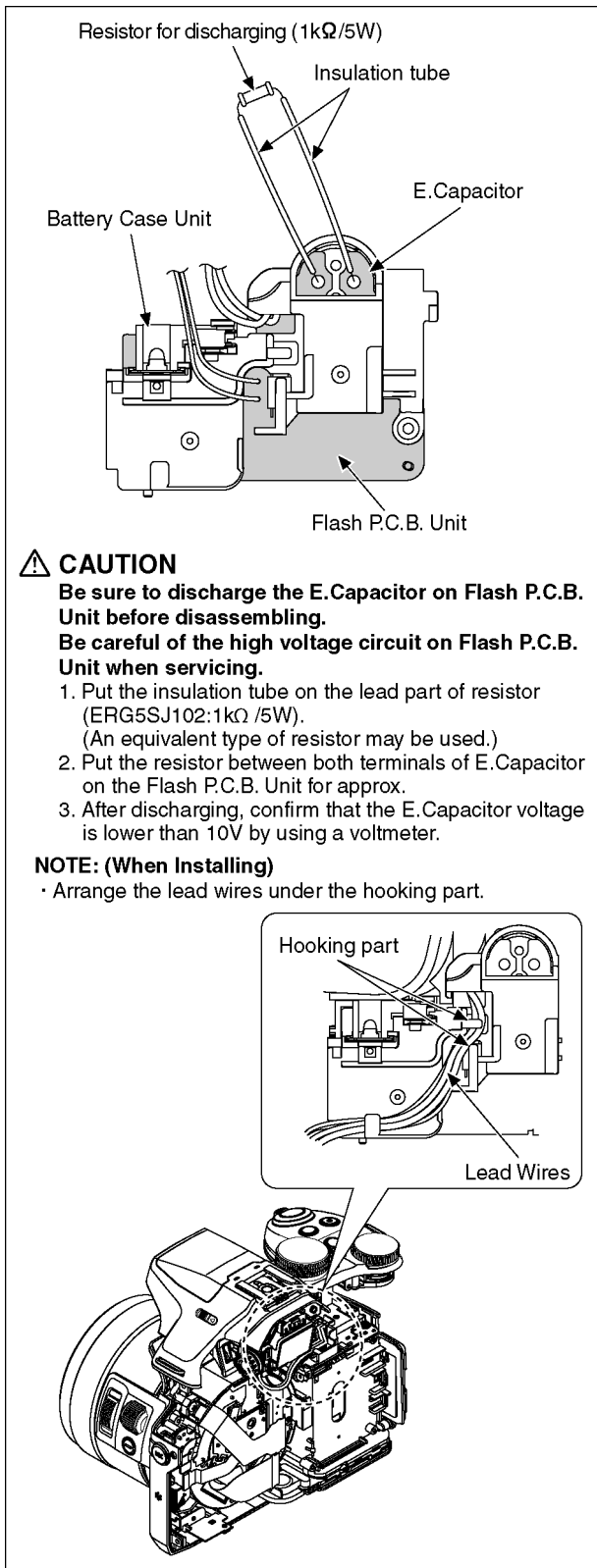

(Fig. D11)

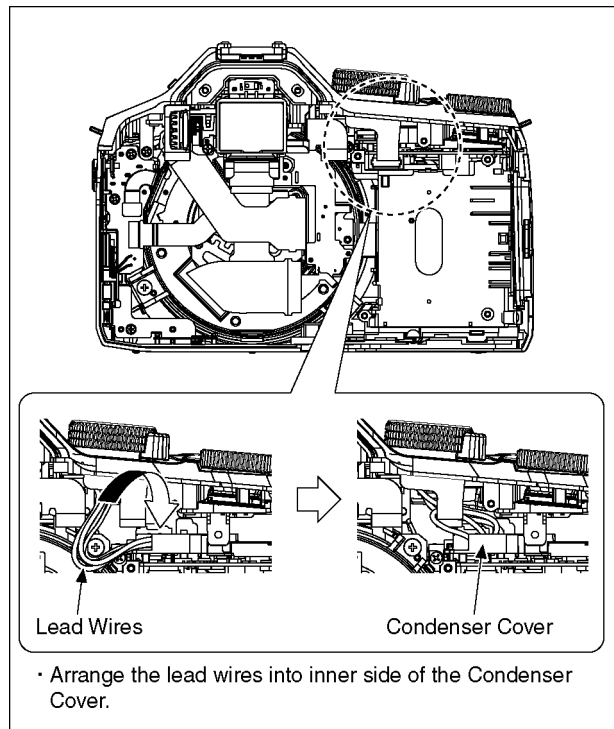

(Fig. D12)

9.3.4. Removal of the Lens Unit

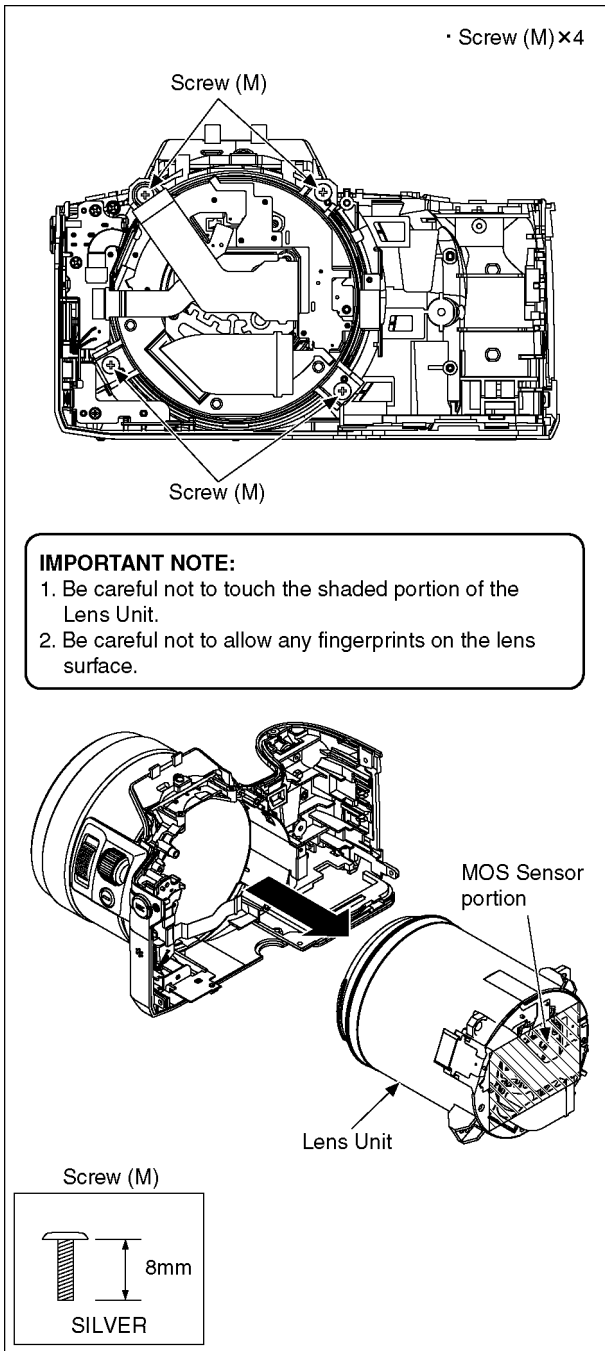

(Fig. D13)

9.3.5. Removal of the Mic Jack Holder, Mic Jack P.C.B. and Speaker

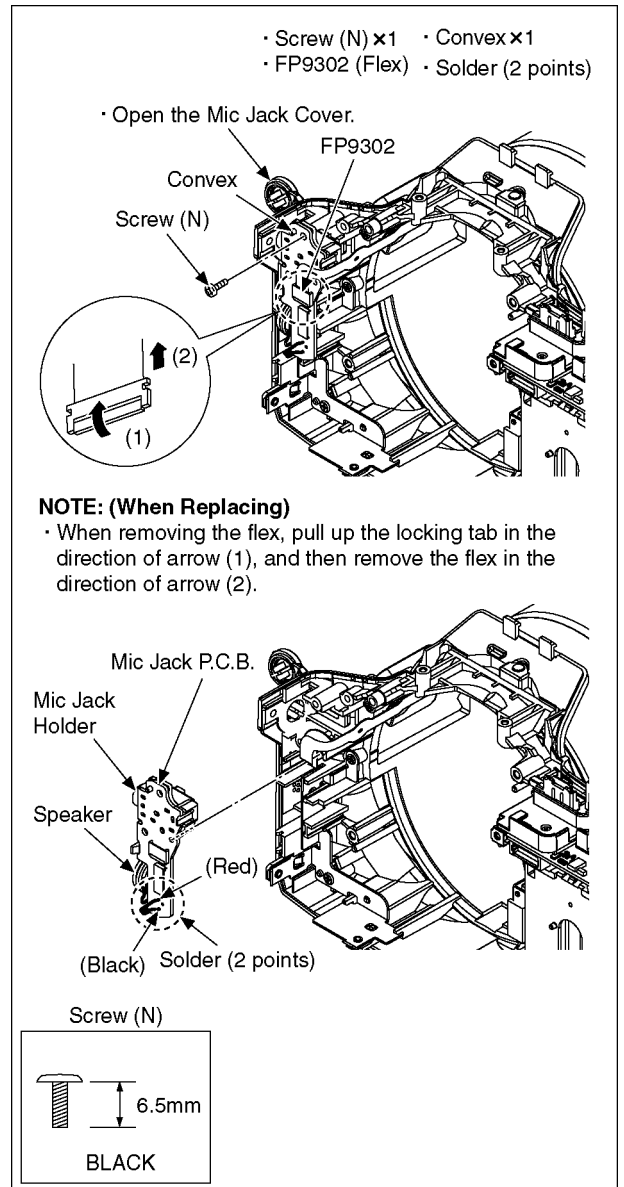

(Fig. D14)

9.3.6. Removal of the Side Operation Unit and Front Case Unit

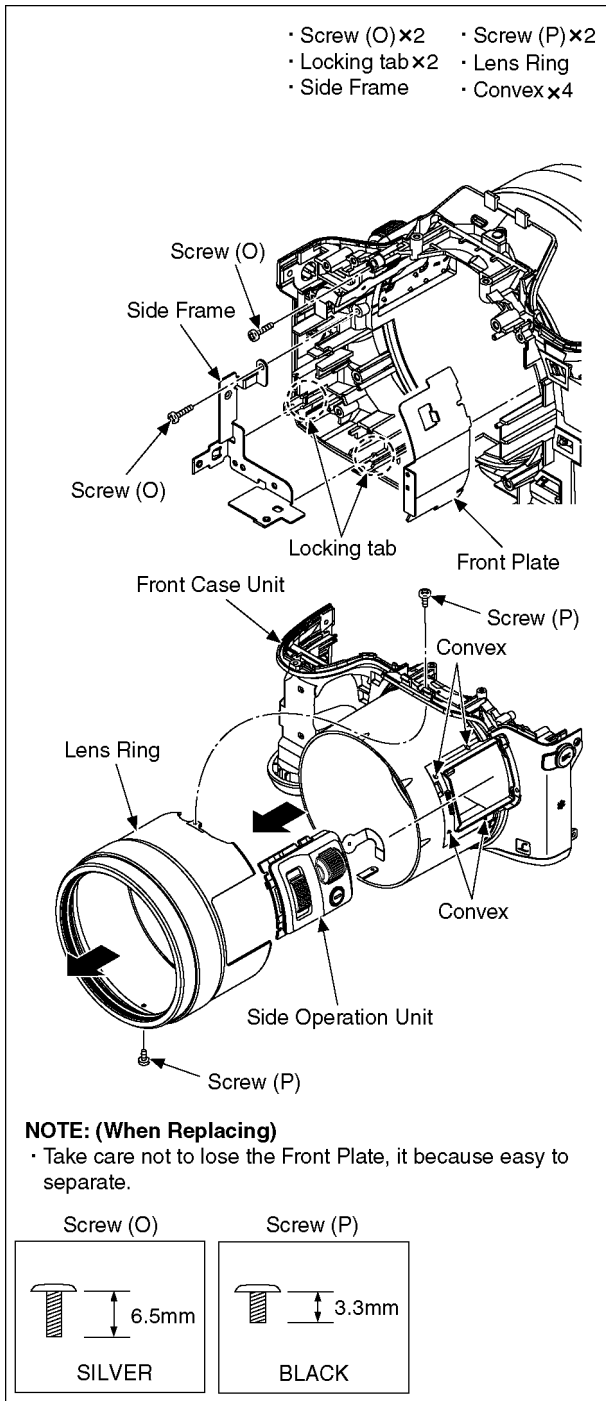

(Fig. D15)

9.3.7. Removal of the Battery Door Unit

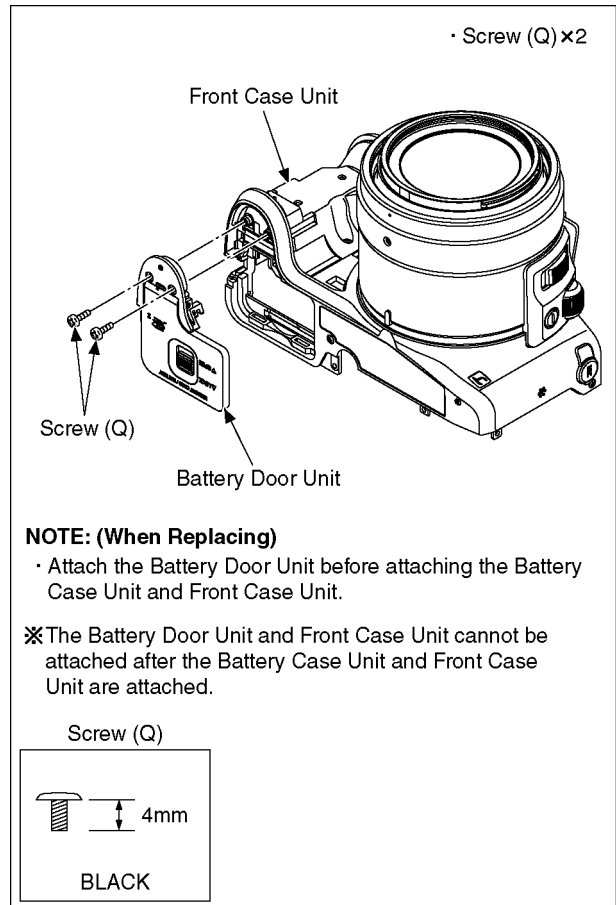

(Fig. D16)

9.3.8. Removal of the Flash P.C.B. Unit

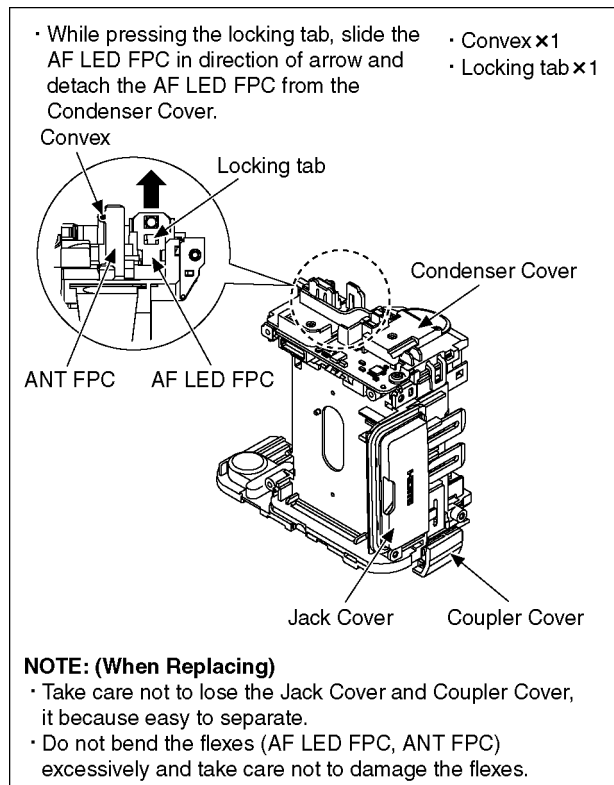

(Fig. D17)

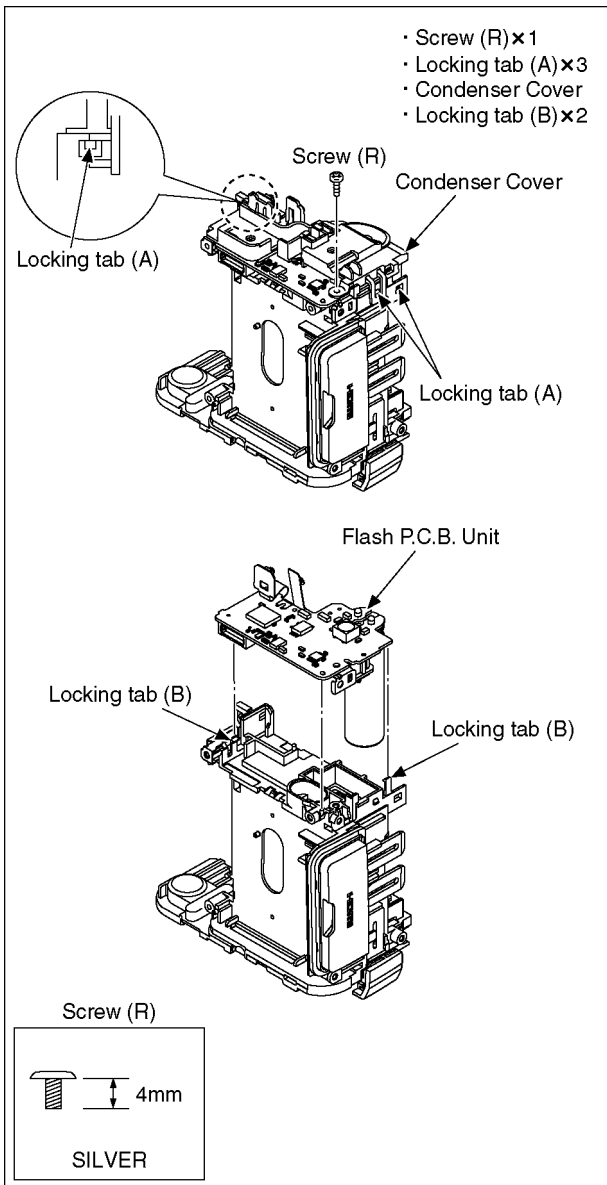

(Fig. D18)

IMPORTANT NOTICE:

- Take care not apply any bending load to the charging E.Capacitor.
- It brings about the possibility of Flash P.C.B. Unit and/or component damage on the Flash P.C.B. Unit.

• Solder (4 points)

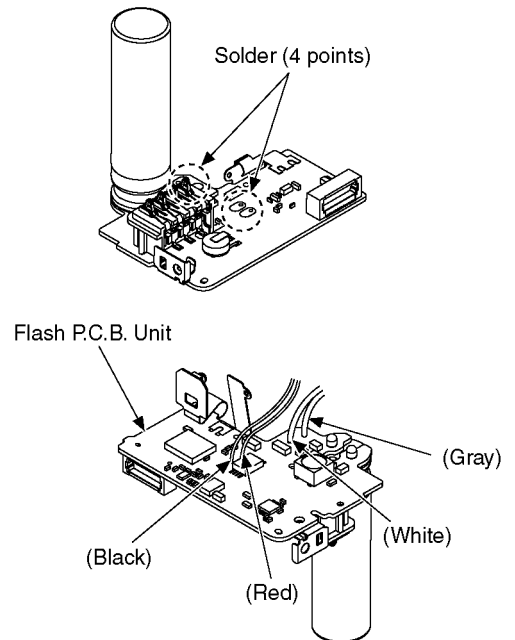

NOTE: (When Installing)

- Taking care not to mistake colour, do solder lead wires.

(Fig. D19)

9.3.9. Removal of the LVF Module

- Convex (A)×2
- Hooking part (A)×2
- Multi FPC Unit
- Screw (S)×2
- Convex (B)×2
- Locking tap×2
- Hooking part (B)×2
- LVF Cover Unit
- LVF Unit
- Heat Radiation Pad

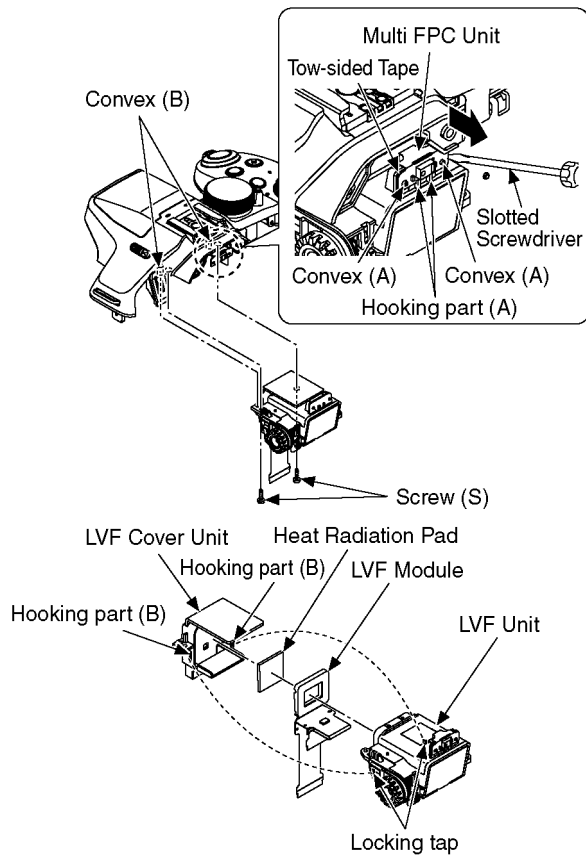

NOTE: (When Replacing)

- Take care not to put any fingerprints on the finder part of LVF Unit.
- Remove the Multi FPC Unit slowly and carefully.

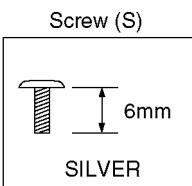

How to Install

1. Paste the Heat Radiation Pad to the LVF Module.
(Do not overlap the P.C.B. of LVF Module.)

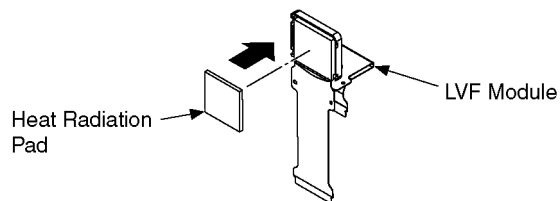

2. Install the LVF Module to LVF Unit.
(Heat Radiation Pad is outside.)
3. Install the LVF Cover Unit at the locking tabs.
(Do not put in the flex.)

(Fig. D20)

9.3.10. Removal of the Flash Tray Unit, Shoe Spring and Flash Case Top

- Screw (T)×3
- Flash Tray Unit
- Shoe Spring
- Screw (U)×2
- Locking tab×2
- Flash Case Top

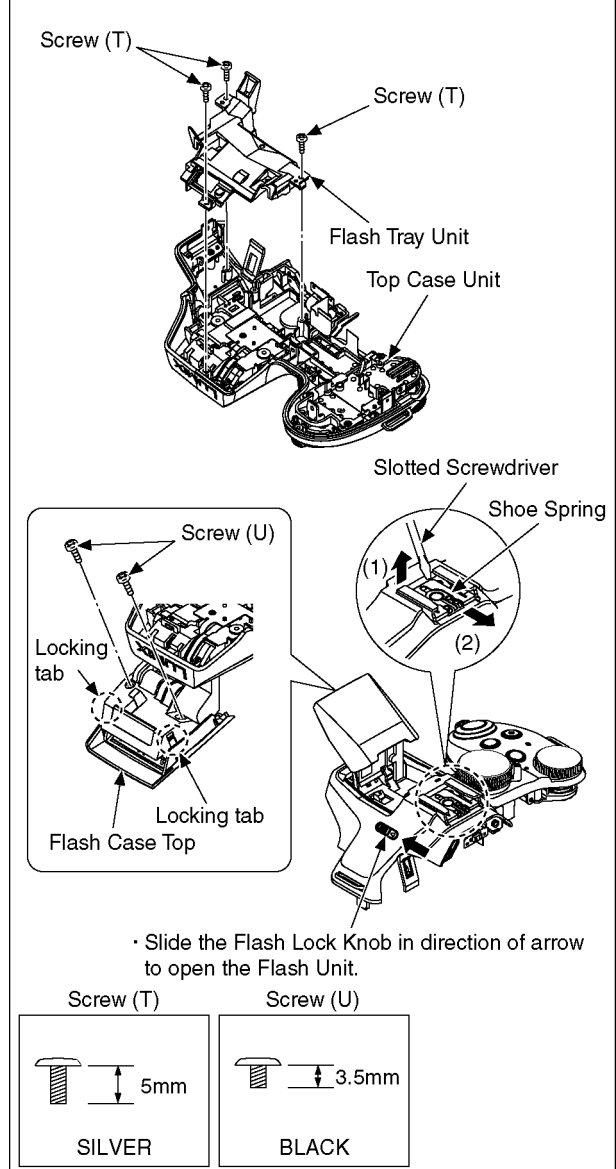

(Fig. D21)

9.3.11. Removal of the Rear Operation Unit and Hinge SW FPC

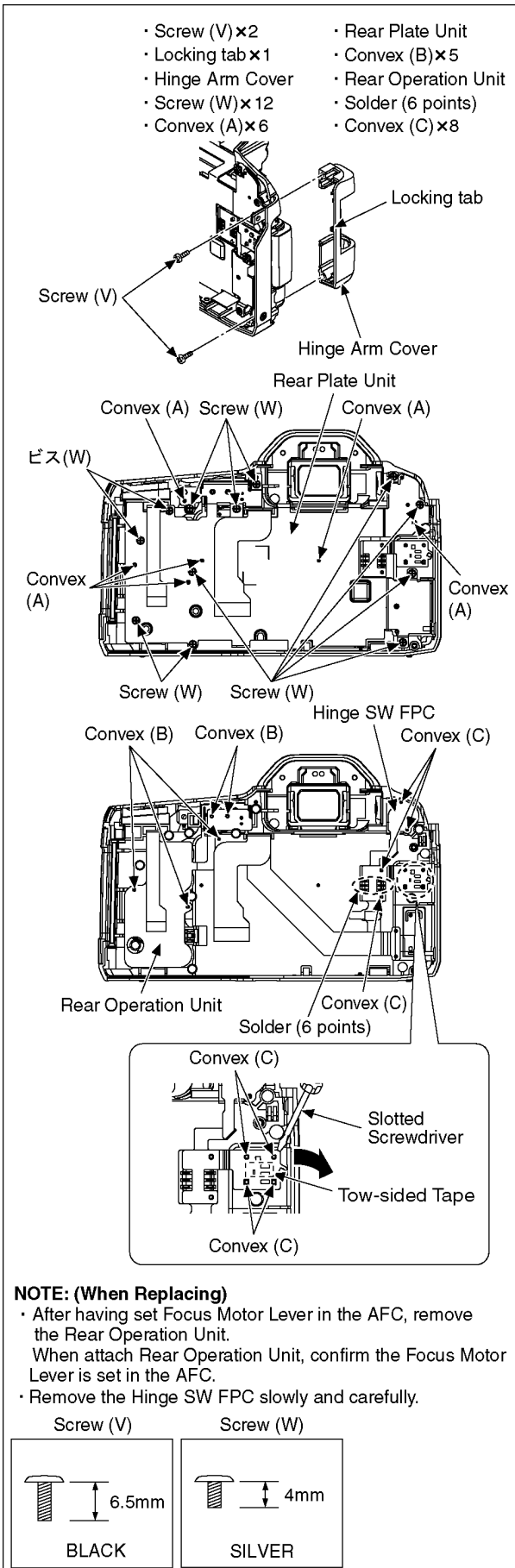

(Fig. D22)

9.3.12. LCD Hinge Unit (with LCD Unit)

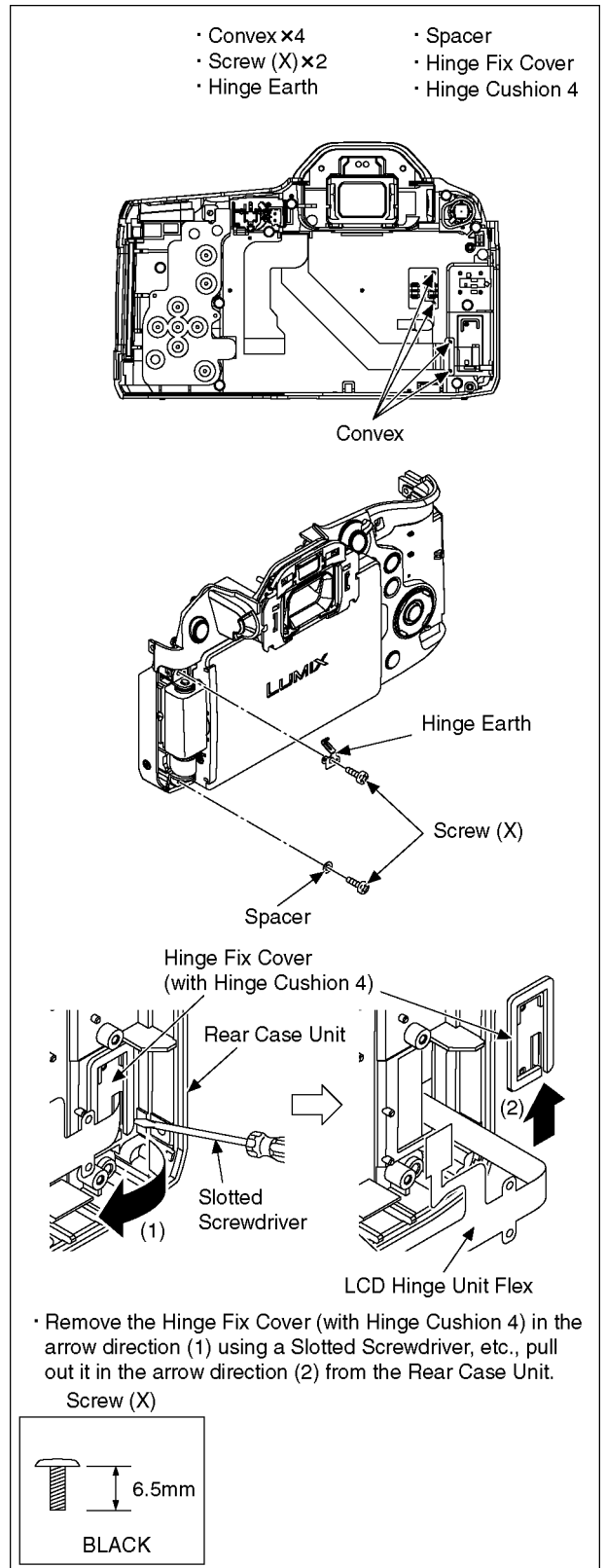

(Fig. D23)

9.3.13. Removal of the LCD IF P.C.B., MR Sensor FPC and LCD Unit

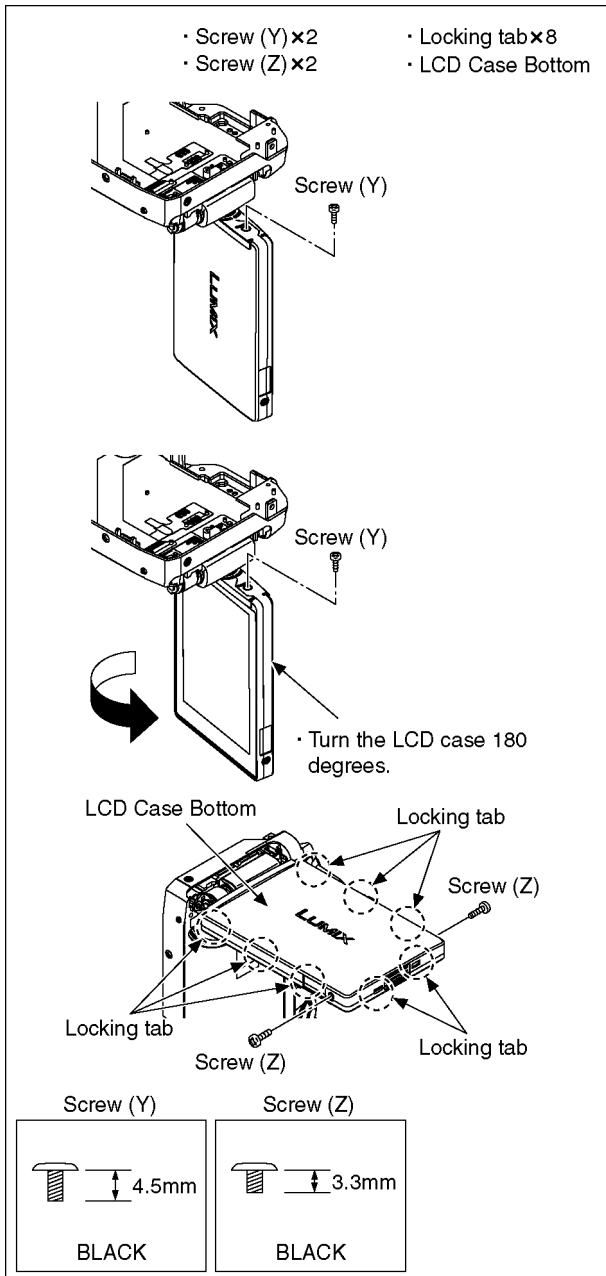

(Fig. D24)

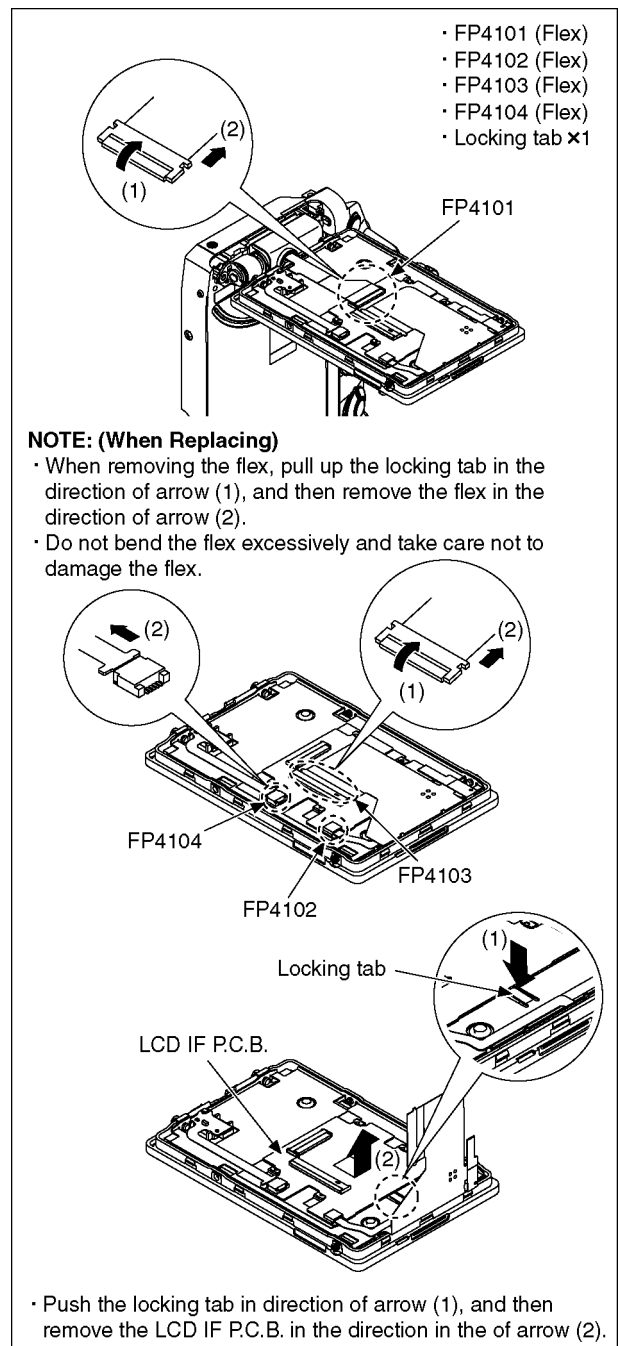

(Fig. D25)

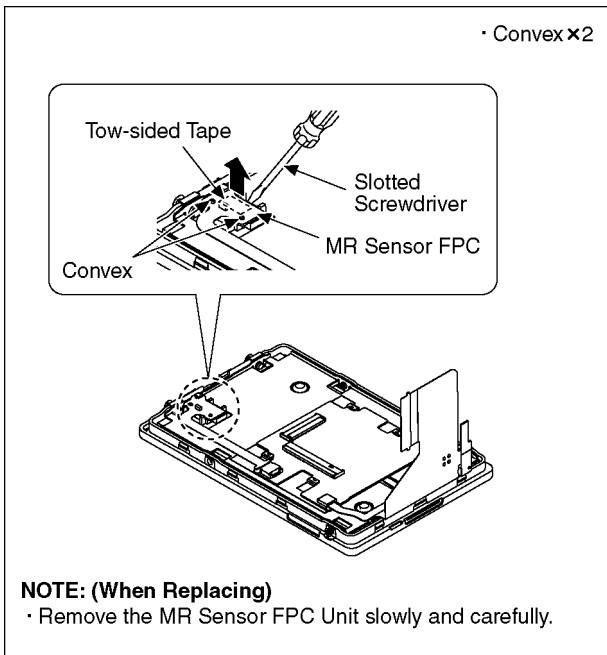

(Fig. D26)

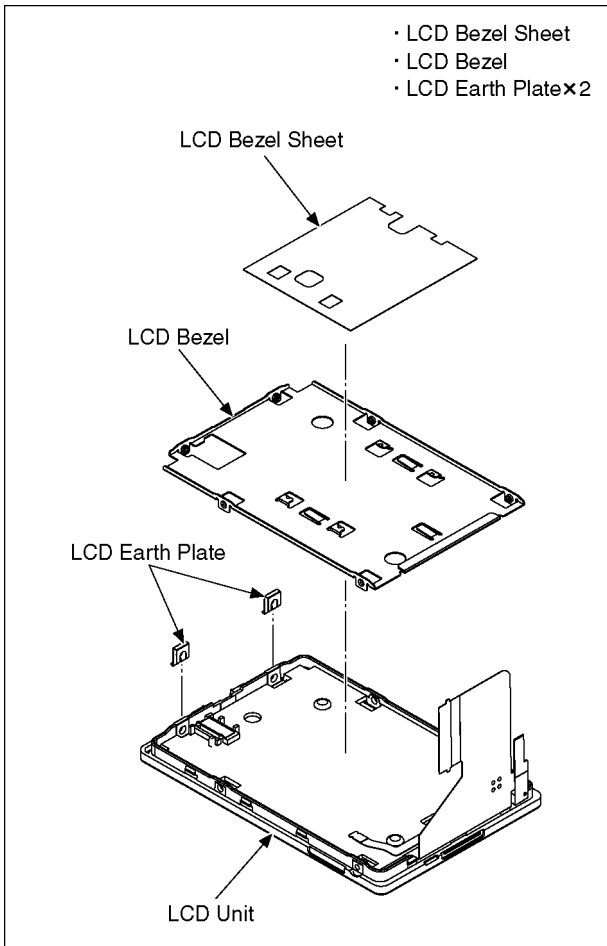

(Fig. D27)

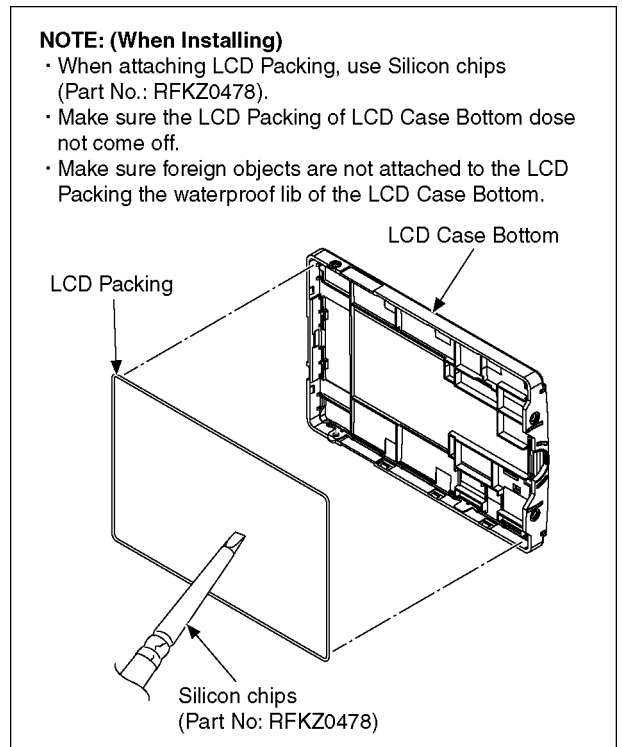

(Fig. D28)

9.4. Lens Disassembly Procedure

Precaution:

1. Do not remove the MOS unit when disassembling or re-assembling the lens in order to maintain it clean.
The screws for fixing the MOS unit to the master flange unit are locked by glue with the adjustment of the installation angle of the MOS unit to the lens (optical axis adjustment) finished.
When remove it, refer to item "9.5."
2. Keep dust or dirt away from the lens.
To remove dirt or dust from the lens, blow with dry air.
3. Do not touch the lens surface.
4. Use lens cleaning KIT (VFK1900BK).
5. Apply grease as shown on item "9.4.8." and "9.4.9." in the figure.

9.4.1. Removal of the Lens Flex Unit

1. Unscrew the 2 screws (A).
2. Remove the 10 Ribs.

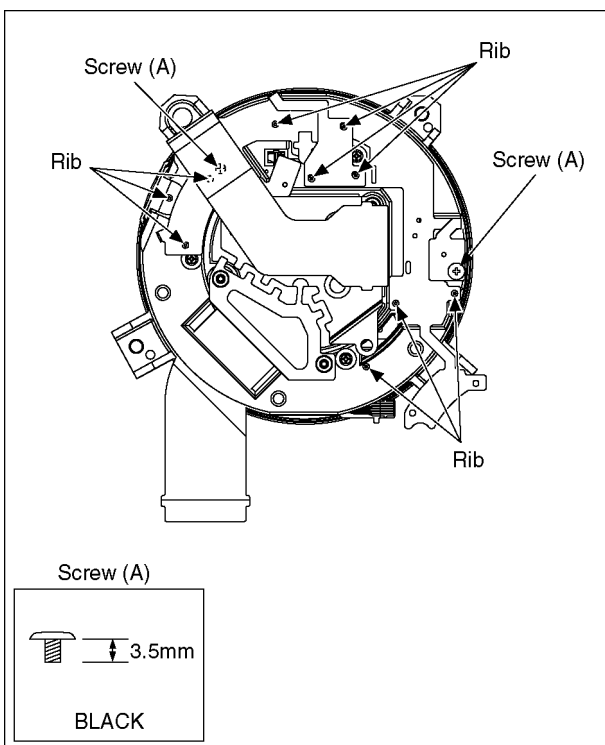

3. Remove the 3 connector.
4. Remove the lens flex unit.

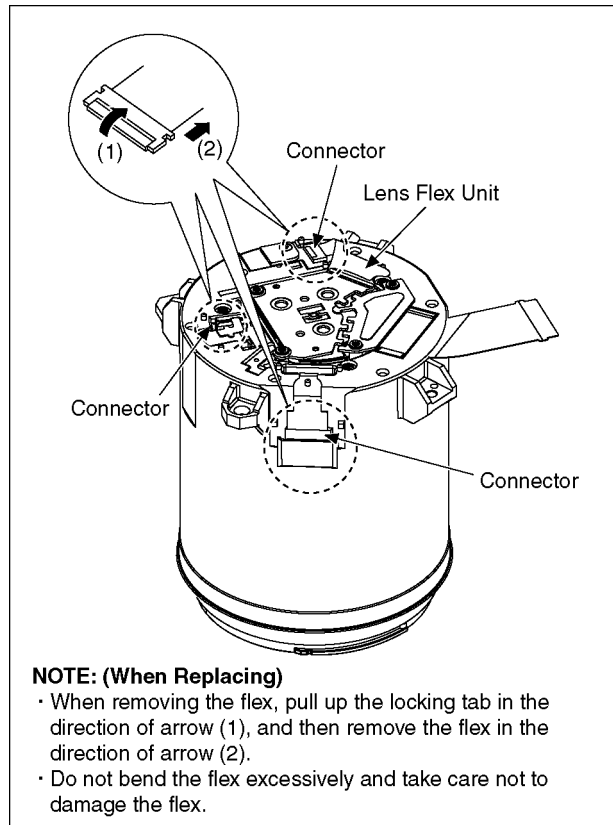

9.4.2. Removal of the Master Flange Unit

1. Unscrew the 3 screws (B).
2. Remove the master flange unit.

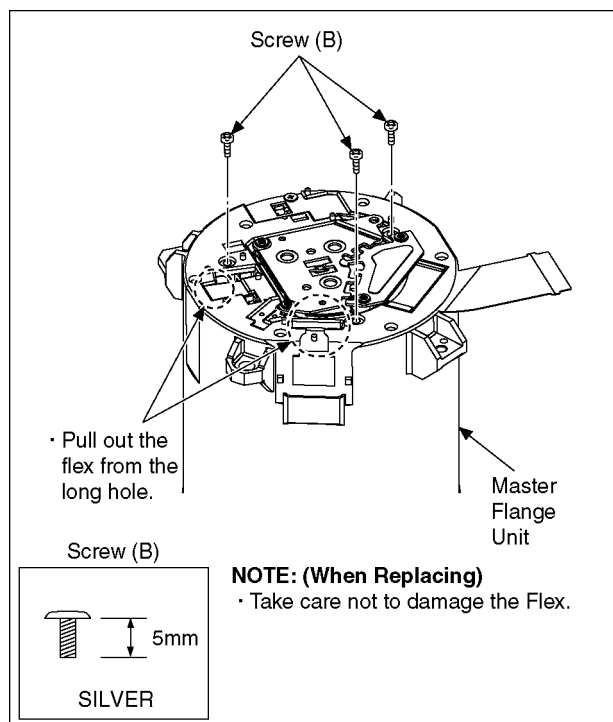

How to Install

1. Insert the connector joint of shutter in slit part of Middle Frame Unit.
2. Pass the Shutter Flex and Focus Motor Flex through the long hole of Master Flange Unit.
3. Fasten the 3 screws (B).

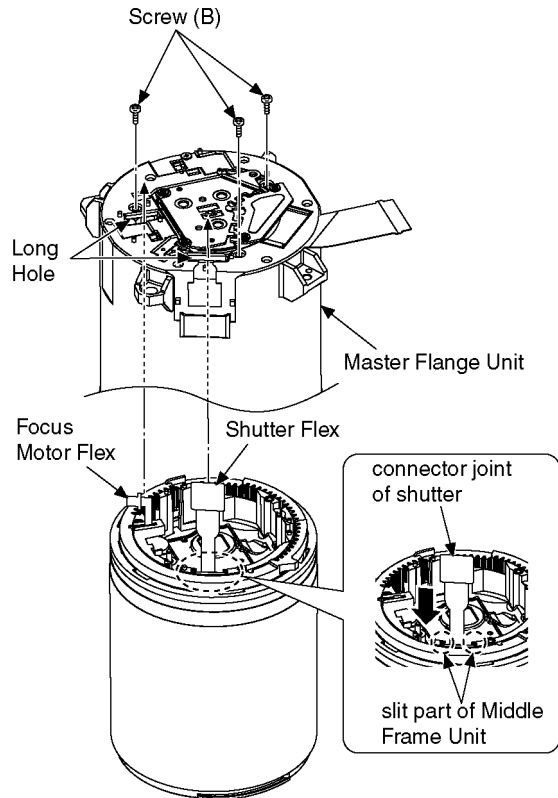

NOTE: (When Replacing)

- Take care not to damage the Flex.

9.4.3. Removal of the Zoom Motor

1. Unscrew the 2 screws (C).

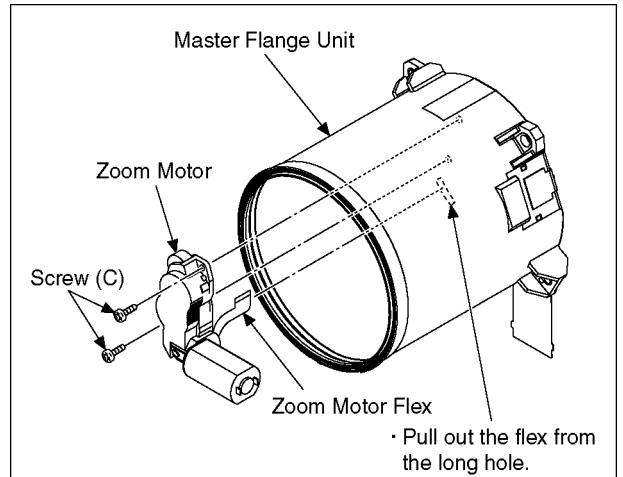

NOTE: (When Installing)

- Install the Zoom Motor Flex in the hole of Master Flange Unit, and put in them.
- ※ Attach a scotch tape (10 cm) to the Zoom Motor Flex so it can easily be inserted to the long hole.

Screw (C)

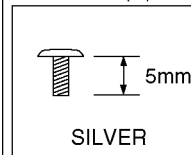

9.4.4. Removal of the 1st Lens Frame Unit

1. Turn the cam frame in the direction of arrow fully, and remove the 1st lens frame unit.



How to Install

1. Align the groove of cam frame and the groove of middle frame unit.

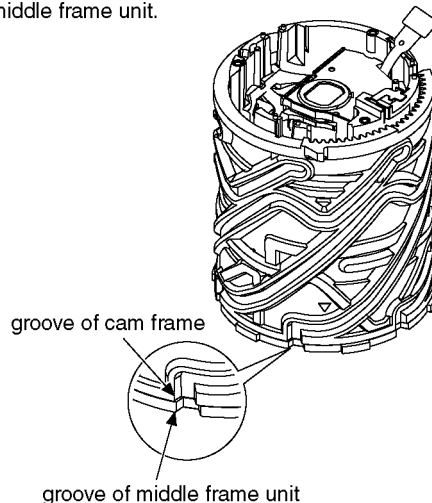

2. Align the Δ mark of cam frame and concave of 1st lens frame unit, and then install them.

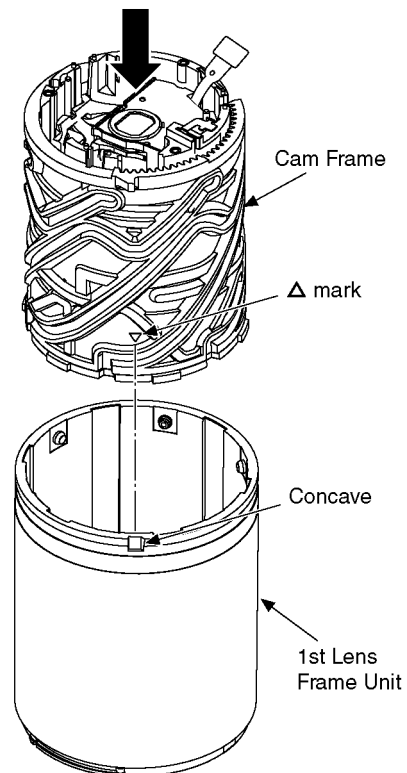

NOTE: (When Installing)

- Take care not to put fingerprint of the lens.

3. Install the cam frame. And turn the cam frame in the direction of arrow a little.

Rotation angle: 2 gear \pm 1 gear

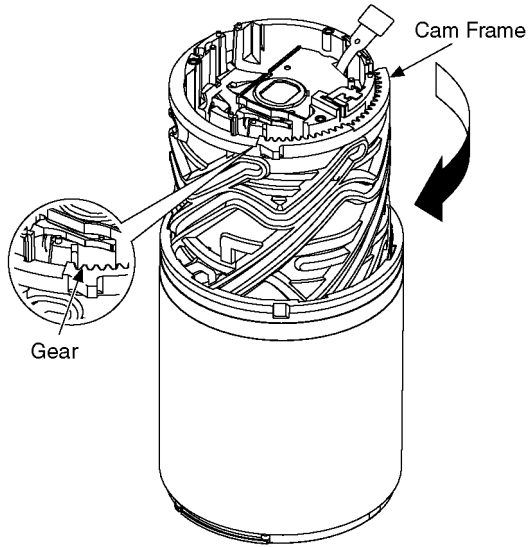

4. Insert the shutter flex to slit of middle frame unit.

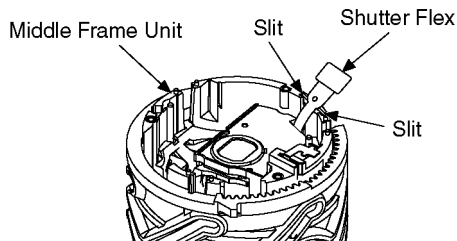

NOTE: (When Replacing)

- Take care not to damage the Flex.
- Take care not to put fingerprint of the lens.

9.4.5. Removal of the 5th Lens Frame Unit

1. Remove the 5th lens frame unit in the direction of arrow.

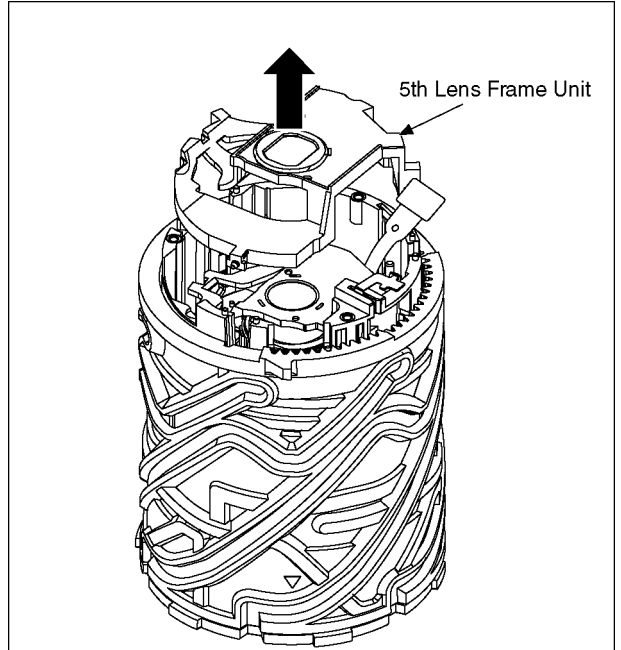

NOTE: (When Replacing)

- Take care not to put fingerprint of the lens.

How to Install

1. Align the convex of 5th lens frame unit and groove of middle frame unit, and then install them.

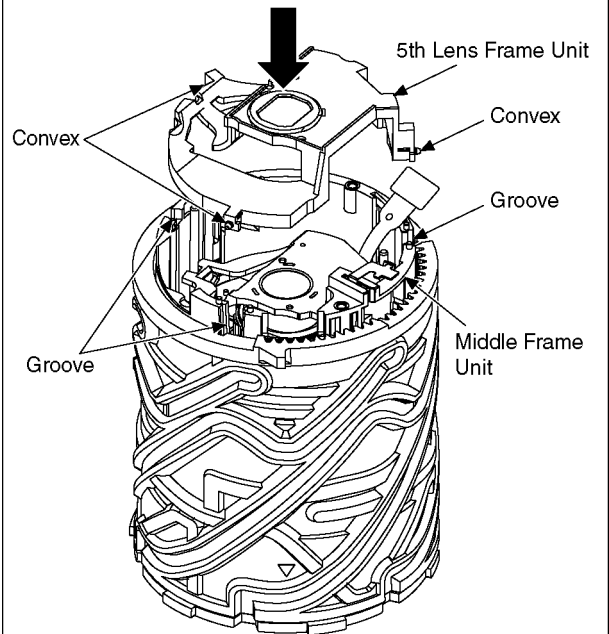

NOTE: (When Installing)

- Take care not to put fingerprint of the lens.

9.4.6. Removal of the 2nd Lens Frame Unit

1. Hold the middle frame unit, and turn the cam frame unit in the direction of arrow (1) fully.(about half turn)
2. Reverse the cam frame, and remove the 2nd lens frame unit. (Catch the 2nd lens frame unit.)

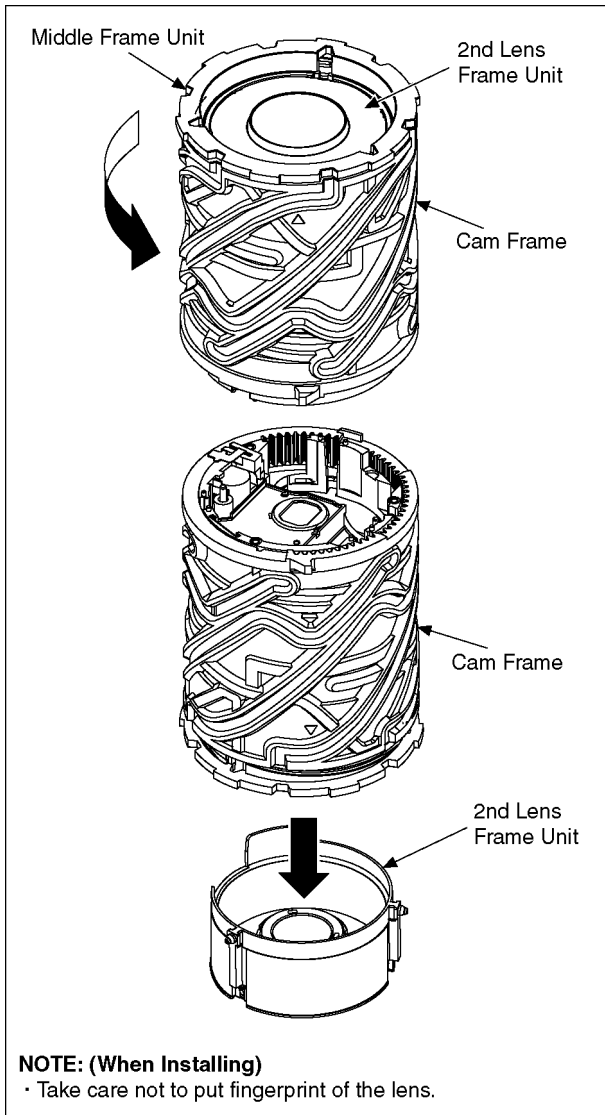

How to Install

1. Reverse the cam frame, and push the 3rd lens frame unit.

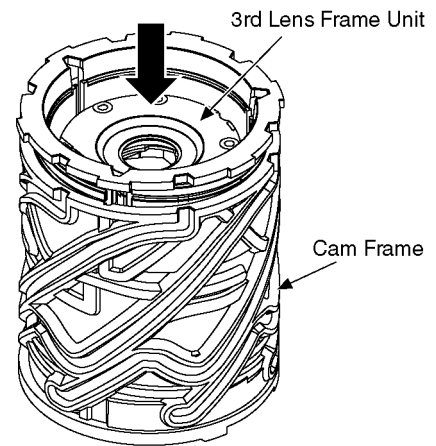

2. Turn the cam frame unit in the direction of arrow fully.

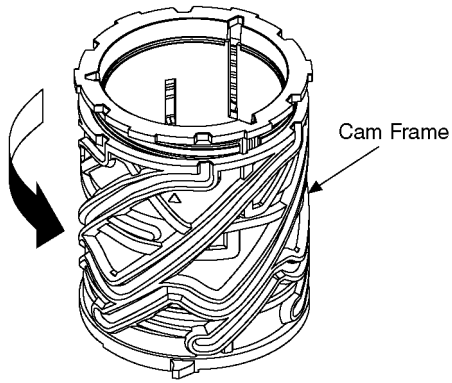

3. Align the convex (3 points) of 2nd lens frame unit and groove of middle frame unit, and then install them. (Align the concave of 2nd lens frame unit and focus motor unit.)

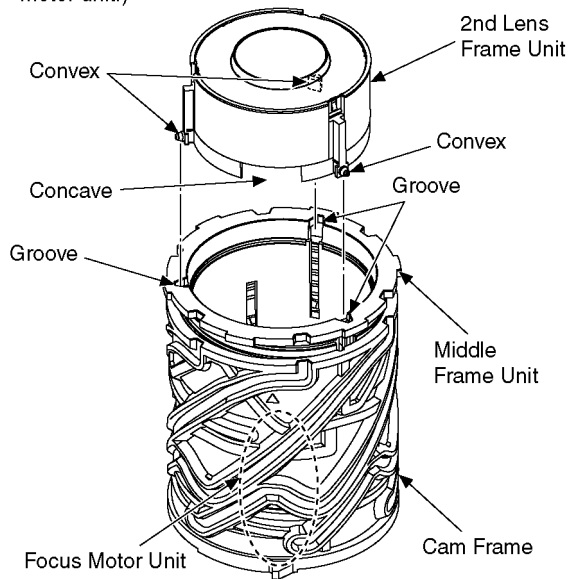

NOTE: (When Installing)

· Take care not to put fingerprint of the lens.

4. Turn the cam frame the direction of arrow fully.

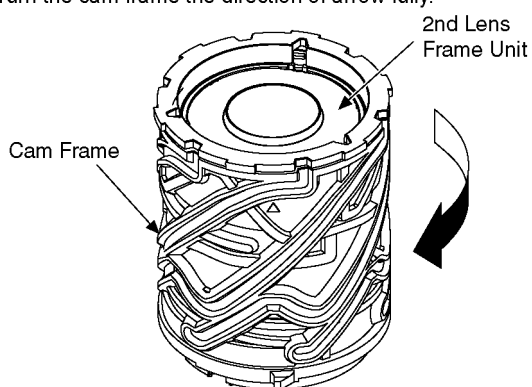

9.4.7. Removal of the Cam Frame Unit

1. Turn the cam frame unit in the direction of arrow (1) fully.(about half turn)
2. Move the 3rd lens frame unit to bottom. And turn the cam frame unit in the direction of arrow (2) fully, and remove the cam frame unit.

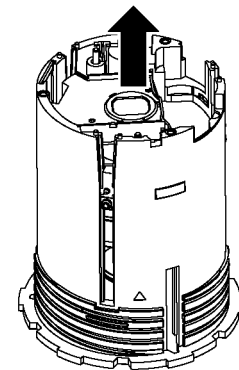
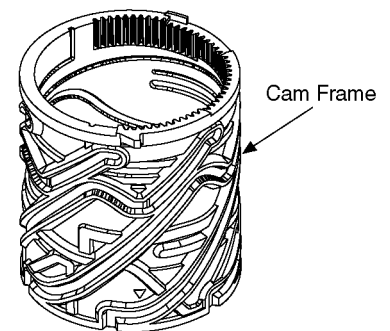
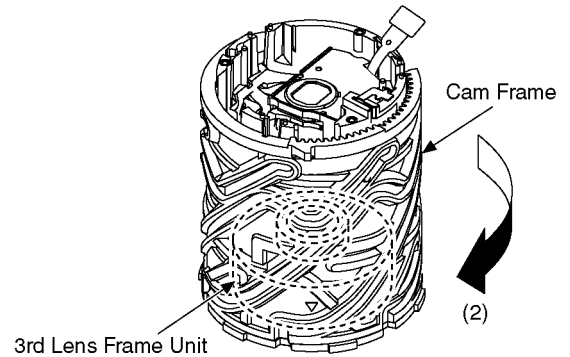
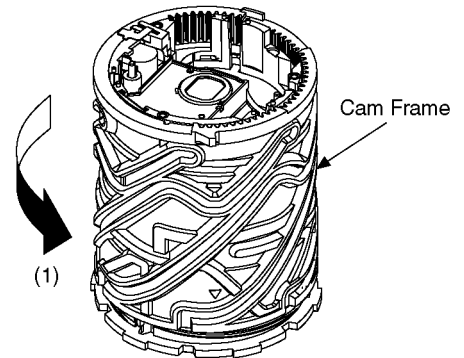

How to Install

1. Align the Δ mark of middle frame unit and Δ mark of cam frame, and then install them.

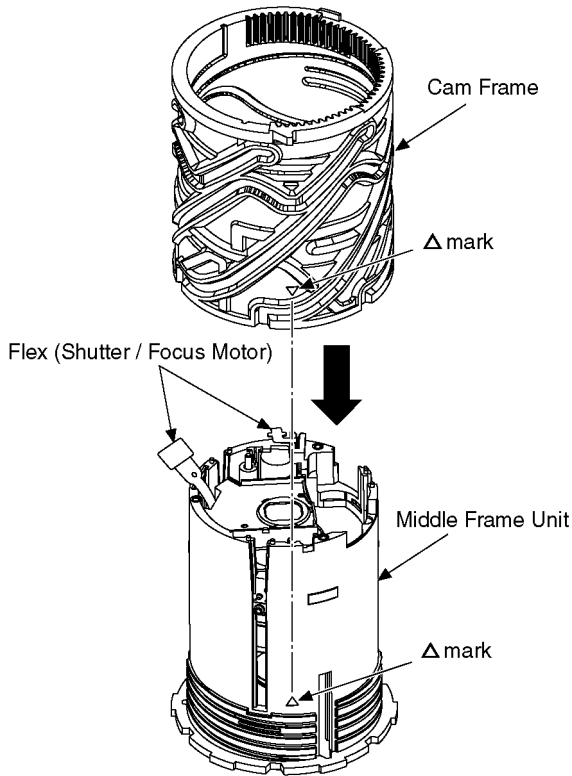

NOTE: (When Replacing)

- Take care not to damage the Flex.

2. Turn the cam frame the direction of arrow fully.

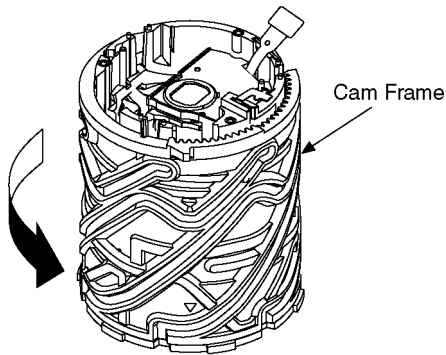

9.4.8. Removal of the Focus Motor Unit

1. Unscrew the 2 screws (D).
2. Remove the focus motor unit.
(Also remove the flex from groove.)

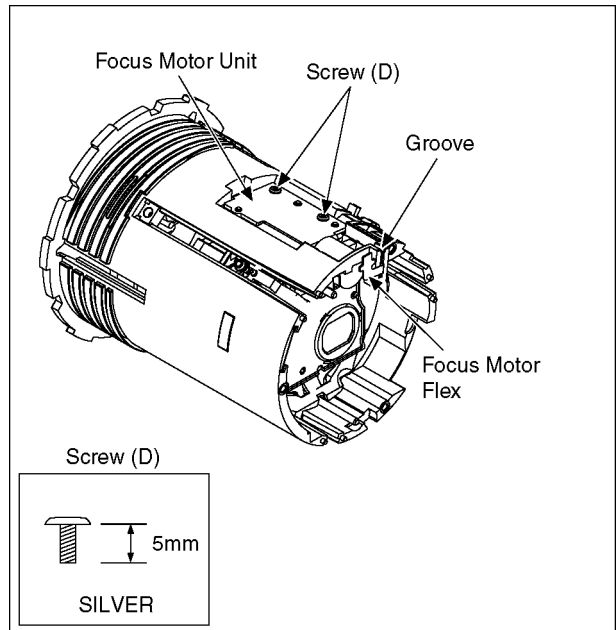

How to Install

1. Blow air to the screw shaft of focus motor unit to prevent the adhesion of foreign material.
2. Apply grease to the screw shaft of focus motor unit.

■ Grease Application Area

Grease: RFKZ0472

Amount application: $4.5 \pm 0.3\text{mg}$

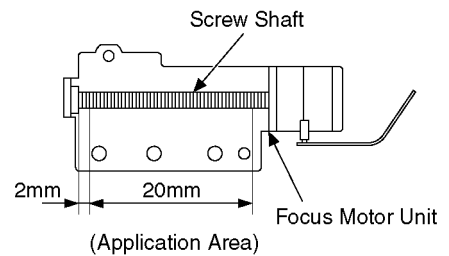

3. Movement the 4th lens frame unit to reference position.

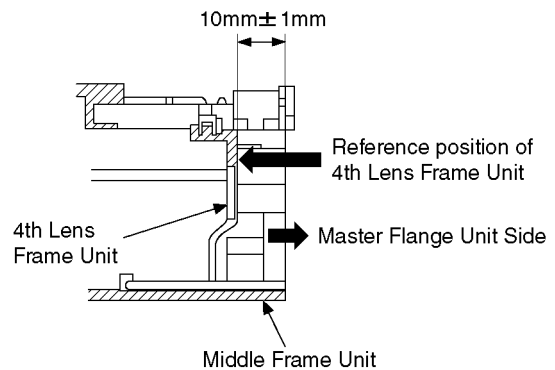

4. Align the screw shaft and rack of 4th lens frame unit.

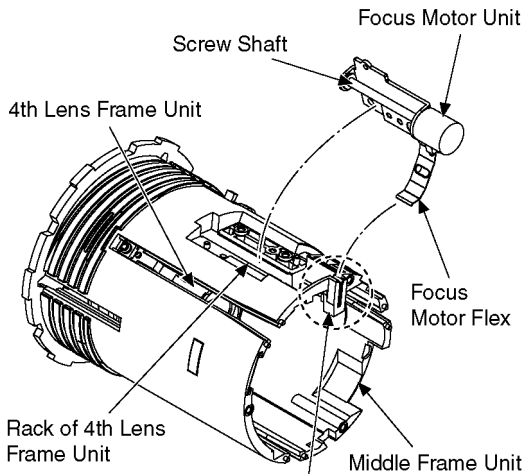

• Be installed to ensure the focus motor flex.

9.4.9. Removal of the 4th and 3rd Lens Frame Unit.

1. Remove the 4th lens frame unit and 3rd lens frame unit from middle frame unit.

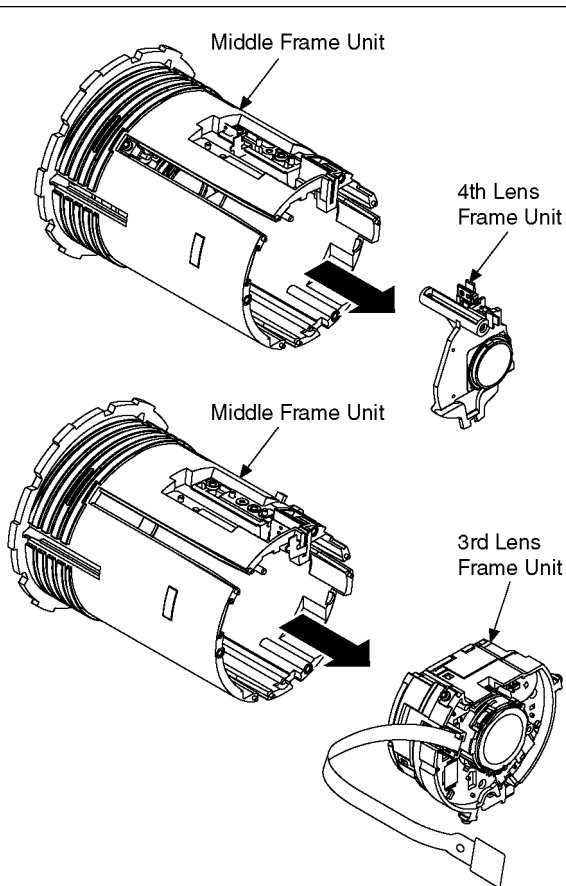

NOTE: (When Replacing)

- Take care not to damage the Flex.
- Take care not to put fingerprint of the lens.

How to Install

1. Align the convex of 3rd lens frame unit and groove of middle frame unit, and then install them.

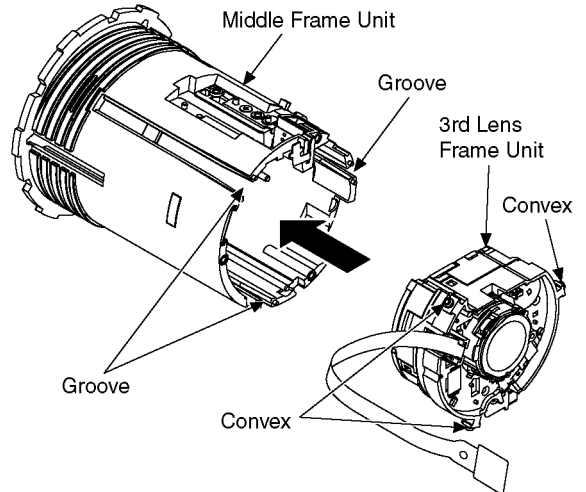

2. Align the hole and groove of 4th lens frame unit and shaft of middle frame unit, and then install them.

• Pass through the flex of 3rd Lens Frame Unit.

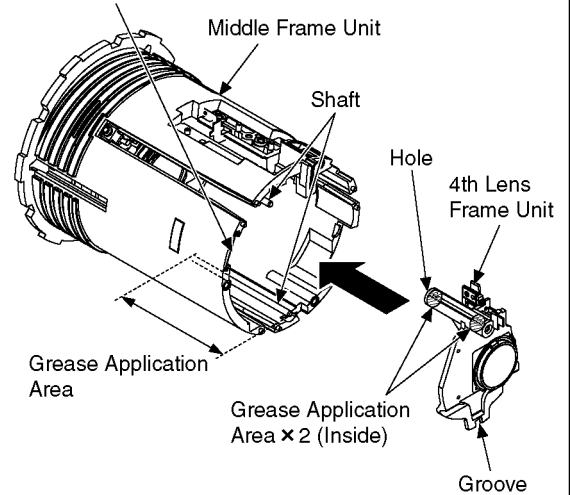

NOTE: (When Installing)

- Take care not to damage the Flex.
- Take care not to put fingerprint of the lens.

■ Grease Application Area

- Hole of 4th lens frame unit (Inside)
Grease: RFKZ0472
Amount of application: $10 \pm 1 \text{mg} \times 2$
- Shaft
Grease: RFKZ0472
Amount of application: $1.5 \pm 0.1 \text{mg}$

9.5. Removal of the MOS Unit

When remove the MOS unit once (the screw(E) is loosened even a little), the optical tilt adjustment is required.

When loosen the screw(E), the optical tilt adjustment is necessary at the end of assembling.

(Refer to item "10.3.2.")

To prevent the MOS unit from catching the dust and dirt, do not remove the MOS unit except replacing it.

1. Unscrew the 4 screws(E).
2. Remove the MOS unit.

IMPORTANT NOTICE:

- The screw (E) is fixed by the screw locking glue with the optical tilt adjustment finished. When remove the MOS unit, wipe the screw locking glue away.
- Don't reuse the screw (E) that the screw locking glue adheres to keep dust or dirt away from the MOS unit. (When installing, use new screw (E).)

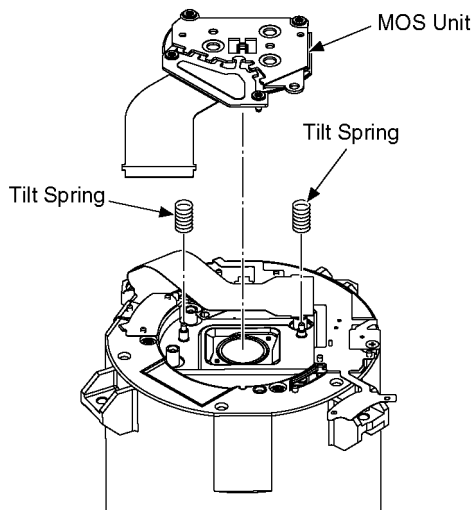
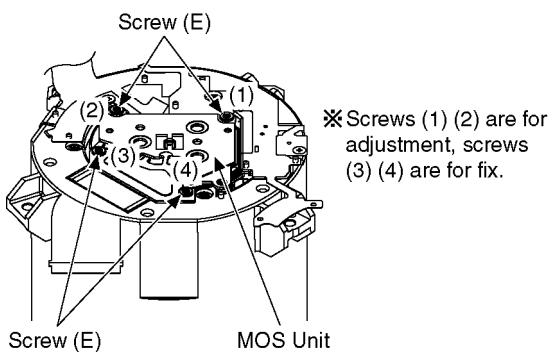

Screw (E)



NOTE: (When Installing)

- Take new screw.
(Don't reuse the screw that the screw locking glue adheres.)
- Tighten the screw and torque according to the following order.
* Install adjustment driver's bit in the torque driver.
Tighten the 4 special screws in order (2)→(1)→(4)→(3).
- Screw torque: $10 \pm 1 \text{ N} \cdot \text{cm}$
- Be sure to execute the optical tilt adjustment with the screw (1) and (2).
- After the adjustment is finished, apply the screw locking glue as shown in the figure below.
- Apply the screw locking glue thinly on the head of screw to the sheet metal with a toothpick.
- Don't apply the screw locking glue where it is applied before disassembling.

Ex)

This is the case where the screw locking glue is applied to the slash area.

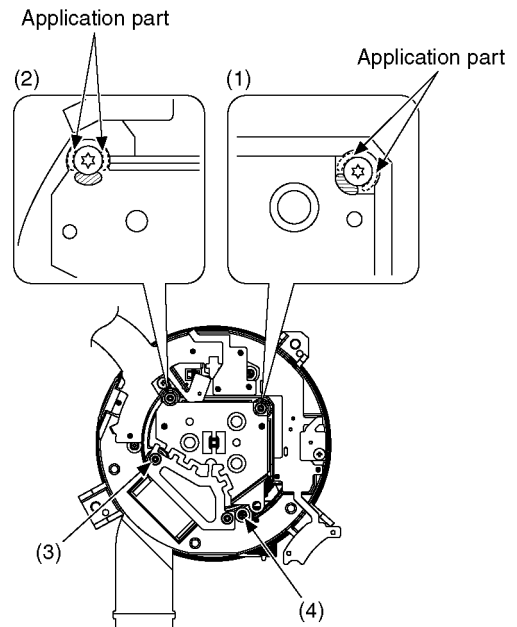

9.6. Main exterior parts assembly procedure

This camera is weather sealed.

When assembling this unit, keep the clearance of "0" to "0.2 mm" between the Top Case Unit and Rear Grip to maintain its weather sealing performance.

(Procedure)

- Tighten the screws in the order of ① to ⑮.
- For the screws ①, ③ and ④, tighten them while pushing the Top Case Unit.

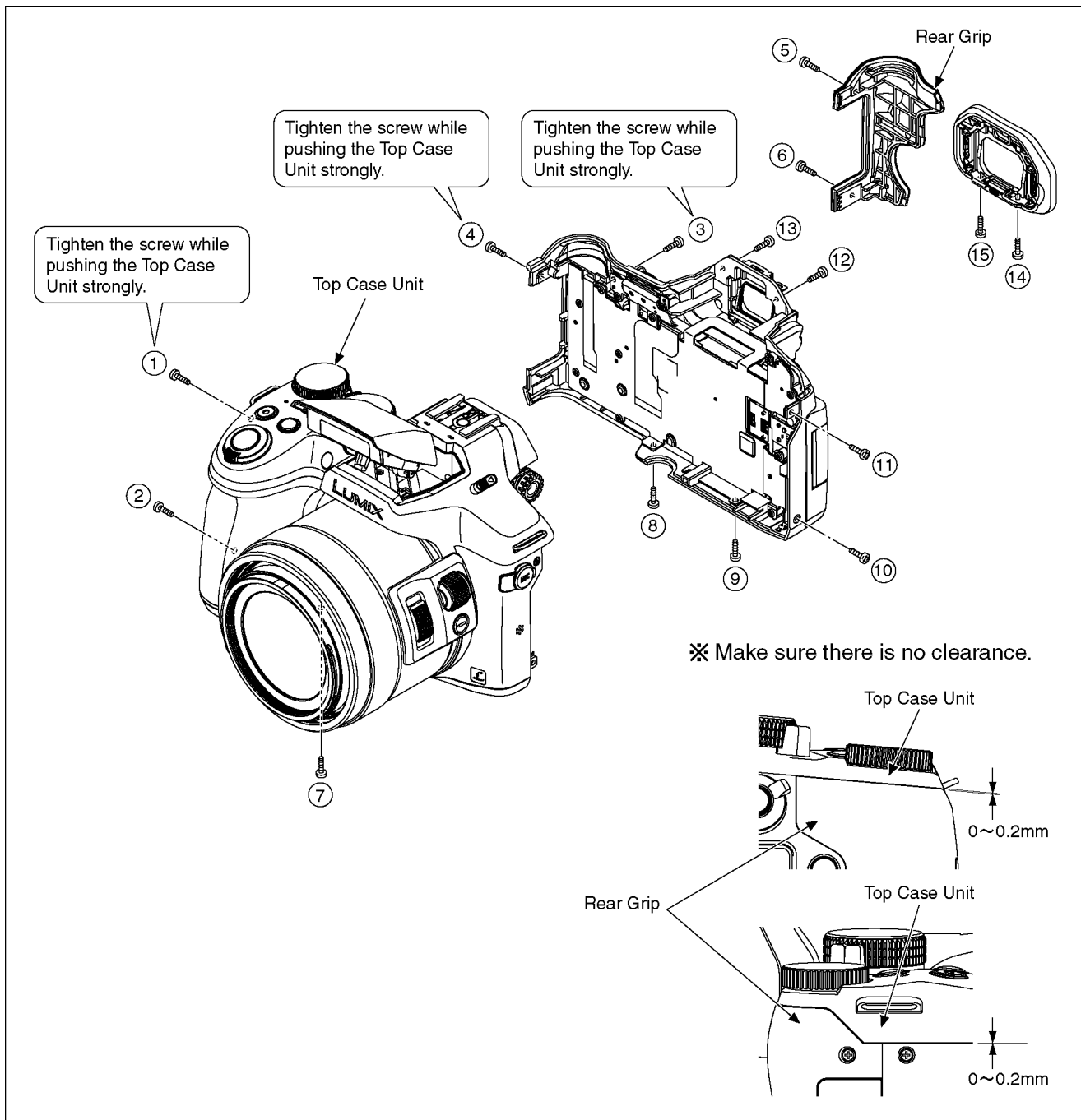

10 Measurements and Adjustments

10.1. Introduction

When servicing this unit, make sure to perform the adjustments necessary based on the part (s) replaced.

Before disassembling the unit, it is recommended to back up the camera data stored in Flash-ROM as a data file.

NOTE: (When replacing the Lens unit, Master Flange Unit and MOS Unit)

- When the MOS Unit is unavoidably removed for Lens Unit, Master Flange Unit and MOS Unit replaced, an optical tilt adjustment is necessary after parts are exchanged.
- The adjustment software (DSC_Tilt) is necessary to execute an optical tilt adjustment.
- The adjustment software "DSC_Tilt" is available at "TSN Website".

NOTE: (When replacing the Main P.C.B.)

- Number of necessary adjustment items decreases by copying the backup data to new Main P.C.B. when adjustment data in old Main P.C.B. can be read by ROM_BACKUP "DSC→SD" in "10.2.2. Flash-ROM Data Backup".
For more details, please refer an item "Main P.C.B. (to which the backup data was copied)" in the table of "10.3.2. Adjustment Specifications".

10.2. Before Disassembling the unit

10.2.1. Initial Setting Release

The cameras specification are initially set in accordance with model suffix (such as EB/EG/GN and so on.).

Unless the initial setting is not released, an automatic alignment software in the camera is not able to be executed when the alignment is carried out.

Note:

- The initial setting should be again done after completing the alignment. Otherwise, the camera may not work properly.
Therefore as a warning, the camera display a warning symbol " ! " on the LCD monitor every time the camera is turned off.
Refer to the procedure described in "3.5.2. Initial Settings" for details.

[How to Release the camera initial setting]

- Preparation:
Attach the fully charged Battery, and insert the memory card (32MB or more).
Remove the lens cap.
- **Step 1. The temporary cancellation of "Initial Settings":**
Set the [Mode dial] to "[P](Program AE mode)".
While pressing [DISP.] button, "[RIGHT] of Cursor buttons" and [AF/AE LOCK] button simultaneously, turn the power on.
- **Step 2. The cancellation of "Initial Settings":**
Press the [Playback] button in order to enter the [Playback] mode.
Press [AF/AE LOCK] button and "[UP] of Cursor buttons" simultaneously, then turn the power off.

The LCD displays the " ! " mark before the unit powers down.

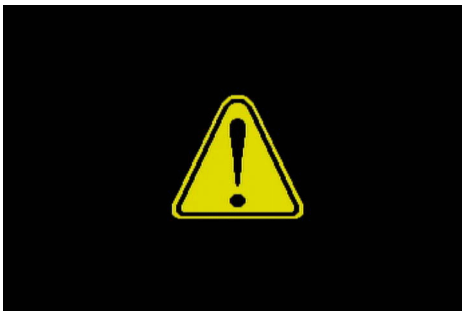

10.2.2. Flash-ROM Data Backup

Number of necessary adjustment items decreases by copying the backup data to new Main P.C.B. when adjustment data in old Main P.C.B. is usually read by ROM_BACKUP "DSC→SD".

It is recommended to backup the Flash-ROM data as the way of return when trouble occurs before disassembling the unit depending on each case.

[ROM_BACKUP (Method of Non-PC backup)]

1. Insert the memory card into the camera.
2. Set the camera to "Temporary cancellation of the initial settings".
3. Select the "SETUP" menu.

From the "SETUP" menu, select "ROM_BACKUP".

NOTE:

This item is not listed on the customer's "SETUP" menu.

4. When this "ROM_BACKUP" item is selected, the following submenus are displayed.

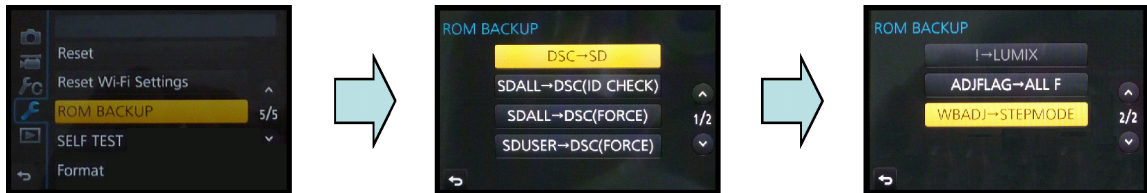

Fig. 2-1

Item	Function	Details
DSC → SD	Save all the DSC's Flash-rom data to Memory Card	<ul style="list-style-type: none"> • DSC's Flash-rom data is saved to the Memory Card as a data file. (DATA BACKUP) -File location: ROOT DIRECTORY in Memory Card. -File Name: <ol style="list-style-type: none"> 1) User Setup Information data: <Model No.>U.txt [Depending on the model, more than one file may be generated (e.g. <Model No.>U.TXT and <Model No.>U3.TXT).] 2) Electrical Adjustment data: <Model No.>F.txt [Depending on the model, more than one file may be generated (e.g. <Model No.>F.TXT and <Model No.>F3.TXT).] • If the concerned file already exists, "OVERWRITE?" message is displayed.
SDALL → DSC (ID CHECK)	Write the all data to DSC's Flash-rom from Memory Card	<ul style="list-style-type: none"> • The backup data stored in the Memory Card is transferred to DSC unit. • ID CHECK: When the model ID is different, data is not transferred.
SDALL → DSC (FORCE)	Write the all data to DSC's Flash-rom from Memory Card	<ul style="list-style-type: none"> • FORCE: Even if the model ID is different, data is transferred. * If the main PCB is replaced, select "SDALL→DSC(FORCE)".
SDUSER → DSC (FORCE)	Only "User setup information" is written from the saved file in the Memory Card to DSC's Flash-rom.	<ul style="list-style-type: none"> • Only the user's "setup" setting condition is transferred to DSC unit. • FORCE: Even if the model ID is different, the data is transferred.
I → LUMIX	Shipping set without initializing "User setup information"	<ul style="list-style-type: none"> • Initial setting is executed without initializing the user's set up setting condition. * The initial setting must be performed while the Self-timer LED is blinking. * The picture data stored in the built-in memory of the DSC is not erased, with this operation.
ADJFLAG → ALL F	Set all adjustment flags completion	<ul style="list-style-type: none"> • Status of the all adjustment flags are changed to "F"(completion).
WBADJ → STEPMODE	ISO: Adjustment WBL, WBM: Setting	<ul style="list-style-type: none"> • ISO: Sensitivity adjustment. • WBL: Setting up the white in low color temperature. • WBM: Setting up the white in high color temperature.

10.2.3. About Light Box

How to remove the Front Hood

In order to utilize maximum of the diffusing surface of light box, some adjustment items need the distance between diffusing surface of light box and camera body becomes several cent-meters.

Before the adjustments, remove the front hood of light box following steps below.

[For RFKZ0523 Light Box]

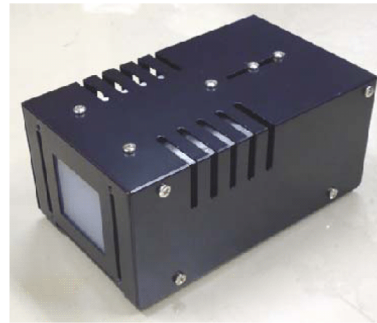
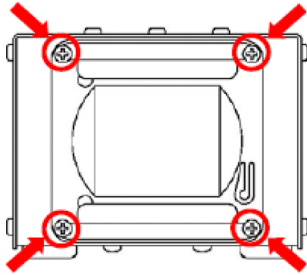

Unscrew the 4 screws, then remove the front hood.

10.3. Details of Electrical Adjustment

10.3.1. How to execute the Electrical Adjustment

It is not necessary to connect the camera to a PC to perform adjustments.

"Flag reset operation" and "Initial setting operation" are required when carrying out the alignment, follow the procedure below.

10.3.1.1. Startup Electrical Adjustment mode

1. Release the initial settings.
2. Insert a recordable memory card (32MB or more).
(Without a memory card, the automatic adjustment can not executed.)
3. Procedure to set the camera into adjustment mode:
 - a. Set the mode dial to "[P] (Program AE mode)".
 - b. Turn the Power on pressing "[LEFT] of Cursor buttons" and [AF/AF LOCK] button simultaneously. LCD monitor displays "SERVICE MODE". (Refer to Fig. 3-1)

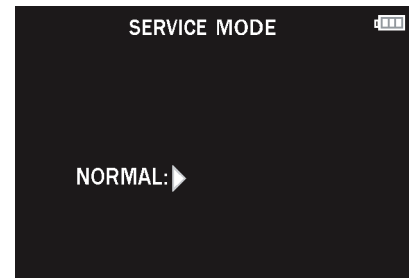

Fig. 3-1

10.3.1.2. Status Adjustment Flag Setting

Reset (Not yet adjusted) the status flag condition.

1. After pressing the [DISP.] button, the LCD monitor displays the Flag status screen. (Refer to Fig.3-2)
2. Select item by pressing the Cursor buttons. (Gray cursor is moved accordingly.)
3. Press the [(Delete/Cancel)/Fn3] button.

NOTE:

The selected item's flag has been changed from "F (green)" to "0 (yellow)".

*Flag conditions:

F (green)

means that the alignment has been completed and the status flag condition is set. In this case, the flag condition should be reset, if you try to carry out the automatic alignment.

0 (yellow)

means that the alignment has been not "completed" and the status flag condition is "reset". In this case, automatic alignment is available.

KEY	F SHTc	F LED	F FOC	F
TPI	F SHD	F CLK	F AA2	F
EST	F ISO	F SKI	F OU4	F
EMC	F SAT	F WKI	F AA3	F
PZM	F WBL	F BKI	F RSnw	F
OIS	F WBM	F DST	F RSst	F
BF	F EYE	F COL	F WNZ	F
IRS	F STB	F MOV	F WiFi	F
ZOM	F---	---	---	
PWK	F---	---	---	
RS2c	F---	---	---	
BK2	F---	---	---	
---	---	---	---	
---	---	---	---	RESET

Fig. 3-2

- To display the "BK2" flag, choose the "WiFi" and press the "[DOWN] of Cursor buttons".
- In case of setting the status flag into set condition again without completion of the alignment, the status flag should be UNDO by using ROM BACKUP function.

10.3.1.3. Execute Adjustment (In case of "OIS Adjustment")

1. Perform step "10.3.1.1." to "10.3.1.2.", to reset the OIS flag status "F" (Set) to "0" (Reset)
2. Press [DISP.] button after Flag reset.
OIS Adjustment screen is displayed on the LCD panel.
(Refer to Fig.3-3)
3. Press the [Shutter] button.
The adjustment will start automatically.



Fig. 3-3

4. When the adjustment is completed successfully, adjustment report menu appears with Green OK on the LCD monitor. (Refer to Fig.3-4)

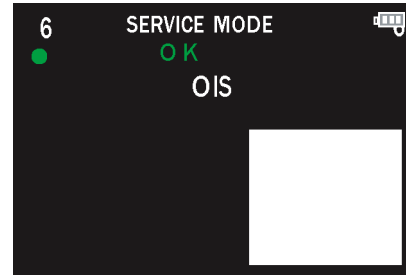

Fig. 3-4

10.3.1.4. Attention point during Adjustment

1. Step "10.3.1.3." procedure shows OIS adjustment as an example. To perform the adjustment, refer to the "10.3.2. Adjustment Specifications" table which shows key point for each adjustment.
2. Do not move the light box, the camera or the chart while adjusting. If one of these is moved accidentally, start the adjustment again.
3. Do not press any buttons/keys until the default menu (Refer to Fig.3-5) is displayed on the LCD monitor. Otherwise, adjustment data may not be stored properly.
4. If the adjustment is interrupted accidentally, the alignment data may not be properly saved in the Flash-ROM.

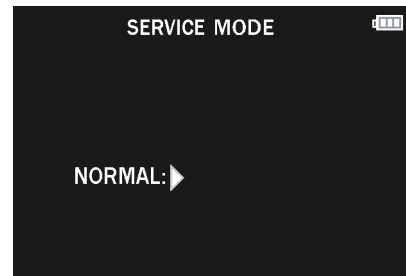

Fig. 3-5

10.3.1.5. Finalizing the Adjustment

1. Several adjustment flags can be reset ("F" into "0") at the same time. In this case, when the adjustment has been completed, the screen will change showing the adjustment for the next item until all reset items are completed.
Also, when the [Shutter] button is pressed, the screen jump to the next adjustment item.
2. To cancel the adjustment mode while in the process of performing the adjustment, follow this procedures.
3. Operate the following, when escaping the Electrical Adjustment mode on the way.
 - (1) Press "[DISP.] button".
 - (2) Press "[RIGHT] of Cursor buttons".

NOTE:

- If adjustment is cancelled with above procedure, adjustment is not completed. Make sure to adjust it later.



10.3.2. Adjustment Specifications

The following matrix table shows the relation between the replaced part and the Necessary Adjustment.

When a part is replaced, make sure to perform the necessary adjustment(s) in the order indicated.

The table below shows all the information necessary to perform each adjustment.

Adjustment order	Adjustment Item	FLAG	Purpose	Replacing Parts							JIG/TOOLS	SET UP	How to Operate		
				MAIN P.C.B./Flash-ROM/VENUS ENGINE	MAIN P.C.B. (When written Backup data)	Lens Part (Excluding Image Sensor)	Image Sensor	Microphone	Flash Part	Electronic Level (IC6201)				Eye Sensor	
1	Optical Tilt	—	Adjustment of MOS Unit installation angle to the Lens	—	—	○	○	—	—	—	—	—	<p>NOTE: It is necessary to use the "DSC_Tilt" software to allow the "Optical tilt adjustment". The Adjustment software "DSC_Tilt" is available at "TSN Website".</p> <ul style="list-style-type: none"> • Optical Tilt Adjustment Chart RFKZ0570 • Optical Tilt Adjustment Driver RFKZ0569: T4 • Camera Stand RFKZ0333J • Torque Driver RFKZ0542 <p>* The screw locking glue is necessary, after adjustment.</p>		
2	Venus Zoom	PZM	Venus Zoom inspection	○	○	—	—	—	—	—	NONE	NONE	<ol style="list-style-type: none"> 1) Change the flag into the "0", and then proceed to the adjustment mode. 2) Press the shutter button fully. (When a result is OK, it is the completion of an inspection.) 		
3	OIS sensor	OIS	OIS sensor output level adjustment	○	—	○	○	—	—	—	NONE	NONE	<ol style="list-style-type: none"> 1) Change the flag into the "0", and then proceed to the adjustment mode. 2) Press the shutter button fully. (When a result is OK, it is the completion of an inspection.) 		
4	Backfocus / GYRO	BF	To have the focus tracking curve be appropriate shape and GYRO sensor adjustment	○	○	○	○*1	—	—	○	—	<ul style="list-style-type: none"> • Collimator RFKZ0422 	<ol style="list-style-type: none"> 1) Set the camera in front of collimator so that the distance between collimator and camera body becomes 2.0 cm as shown in Fig. A. (It is not distance between lens barrel top and diffusing surface of light box.) * Set the camera on a tripod to prevent it from falling down. 	<ol style="list-style-type: none"> 1) Change the flag into the "0", and then proceed to the adjustment mode. 2) Set the camera angle so that the star chart is displayed to the center, and press the shutter button fully. (Green ● mark is displayed on LCD.) 3) Press the shutter button fully, again. (When a result is OK, it is the completion of an inspection.) 	
5	Iris	IRS	Iris adjustment	○	—	○	○	—	—	—	<ul style="list-style-type: none"> • Light Box RFKZ0523 	<ol style="list-style-type: none"> 1) Set the camera in front of light box so that the distance between diffusing surface of light box and camera body becomes 2.0 cm as shown in Fig. B. (It is not distance between lens barrel top and diffusing surface of light box.) 	<ol style="list-style-type: none"> 1) Change the flag into the "0", and then proceed to the adjustment mode. 2) Set the camera angle so that the diffusing surface of light box is displayed on the full of LCD monitor, and press the shutter button fully. (When a result is OK, it is the completion of an inspection.) 		
6	Shutter	SHTs	Shutter speed adjustment	○	—	○	○	—	—	—	<ul style="list-style-type: none"> • Light Box RFKZ0523 	<ol style="list-style-type: none"> 1) Set the camera in front of light box so that the distance between diffusing surface of light box and camera body becomes 2.0 cm as shown in Fig. B. (It is not distance between lens barrel top and diffusing surface of light box.) 	<ol style="list-style-type: none"> 1) Change the flag into the "0", and then proceed to the adjustment mode. 2) Set the camera angle so that the diffusing surface of light box is displayed on the center of LCD monitor, and press the shutter button fully. (When a result is OK, it is the completion of an inspection.) 		
		SHD	Do not use "SHD" adjustment flag for this unit. Use "BK2" adjustment flag, instead.												

Adjustment order	Adjustment Item	FLAG	Purpose	Replacing Parts							JIG/TOOLS	SET UP	How to Operate
				MAIN P.C.B./Flash-ROM/VENUS ENGINE	MAIN P.C.B. (When written Backup data)	Lens Part (Excluding Image Sensor)	Image Sensor	Microphone	Flash Part	Electronic Level (IC6201)			
<ul style="list-style-type: none"> Set "STEPMODE" to adjust 7: ISO, 8: WBL and 9: WBM. <How to switch to "STEPMODE"> 1. Perform "10.2.2. Flash-ROM Data Backup", and select "WBADJ → STEPMODE" for ROM_BACKUP. 2. Press "SET", and move to the flag setting screen at "STEPMODE". ⇒ The screen appears on the LCD. (See Fig. on the right.) 													
<div style="display: flex; justify-content: space-around;"> <div style="text-align: center;"> <p>Normal flag setting screen</p>  </div> <div style="text-align: center;"> <p>[STEPMODE] flag setting screen</p>  </div> </div>													
7	ISO	ISO	ISO sensitivity adjustment	<input type="radio"/>	<input type="radio"/>	<input type="radio"/>	<input type="radio"/>	<input type="radio"/>	<input type="radio"/>	<input type="radio"/>	<ul style="list-style-type: none"> Light Box RFKZ0523 ND0.3 Filter RFKZ0513 	1) Set the camera in front of light box so that the distance between diffusing surface of light box and camera body becomes 2.0 cm as shown in Fig. B. (It is not distance between lens barrel top and diffusing surface of light box.)	1) Change the flag into the "0", and then proceed to the adjustment mode. 2) Set the camera angle so that the diffusing surface of light box is displayed on the center of LCD monitor, and press the shutter button fully. (When a result is OK, it is the completion of an inspection.)
8	White balance (Low color temp.)	WBL	Setting up the white in low color temperature	<input type="radio"/>	<input type="radio"/>	<input type="radio"/>	<input type="radio"/>	<input type="radio"/>	<input type="radio"/>	<input type="radio"/>	<ul style="list-style-type: none"> Light Box RFKZ0523 ND0.9 Filter VFK1164ND09 ND0.3 Filter RFKZ0513 CC-C7.5 Filter RFKZ0511 	1) Set the camera in front of light box so that the distance between diffusing surface of light box and camera body becomes 2.0 cm as shown in Fig. B. (It is not distance between lens barrel top and diffusing surface of light box.)	1) Change the flag into the "0", and then proceed to the adjustment mode. 2) Set the camera angle so that the diffusing surface of light box is displayed on the center of LCD monitor, and press the shutter button fully. (When a result is OK, it is the completion of an inspection.)
9	White balance (High color temp.)	WBM	Setting up the white in high color temperature	<input type="radio"/>	<input type="radio"/>	<input type="radio"/>	<input type="radio"/>	<input type="radio"/>	<input type="radio"/>	<input type="radio"/>	<ul style="list-style-type: none"> Light Box RFKZ0523 ND0.9 Filter VFK1164ND09 ND0.3 Filter RFKZ0513 CC-C7.5 Filter RFKZ0511 CC-Y10 Filter RFKZ0512 LBB2 Filter RFKZ0520 LBB8 Filter RFKZ0521 	1) Set the camera in front of light box so that the distance between diffusing surface of light box and camera body becomes 2.0 cm as shown in Fig. B. (It is not distance between lens barrel top and diffusing surface of light box.)	1) Change the flag into the "0", and then proceed to the adjustment mode. 2) Set the camera angle so that the diffusing surface of light box is displayed on the center of LCD monitor, and press the shutter button fully. (When a result is OK, it is the completion of an inspection.)
<ul style="list-style-type: none"> After adjusting 7: ISO, 8: WBL and 9: WBM, perform Initial Settings once. Then, cancel "STEPMODE". Then again, cancel the Initial Settings. Move to the servicing mode, and continue the subsequent adjustment. 													
10	Offset gain	SAT	Setting up the offset gain	<input type="radio"/>	<input type="radio"/>	<input type="radio"/>	<input type="radio"/>	<input type="radio"/>	<input type="radio"/>	<input type="radio"/>	<ul style="list-style-type: none"> Light Box RFKZ0523 ND0.6 Filter VFK1164ND06 	1) Insert the ND0.6 filter into the slot of light box as shown in Fig. D. 2) Set the camera in front of light box so that the distance between diffusing surface of light box and camera body becomes 2.0 cm as shown in Fig. B.	1) Change the flag into the "0", and then proceed to the adjustment mode. 2) Set the camera angle so that the white is displayed on the LCD monitor fully. 3) Press the shutter button fully. (When a result is OK, it is the completion of an inspection.)
11	Eye sensor	EYE	Inspecting sensitivity of eye sensor	<input type="radio"/>	<input type="radio"/>	<input type="radio"/>	<input type="radio"/>	<input type="radio"/>	<input type="radio"/>	<input type="radio"/>	<ul style="list-style-type: none"> Gray Card RFKZ0506 	1) Set the camera in front of gray card so that the distance between gray card and eye sensor of camera body becomes 4.5 cm as shown in Fig. C.	1) Change the flag into the "0", and then proceed to the adjustment mode. 2) Set the camera angle so that the attachment side of eye sensor and center of the gray card is perpendicular, and press the shutter button fully. (When a result is OK, it is the completion of an inspection.)
12	Flash adjustment	STB	Flash adjustment	<input type="radio"/>	<input type="radio"/>	<input type="radio"/>	<input type="radio"/>	<input type="radio"/>	<input type="radio"/>	<input type="radio"/>	NONE	NONE	1) Change the flag into the "0", and then proceed to the adjustment mode. 2) Press the shutter button fully. 3) Check that a flash shines. (It is different for every model how many times it shines.) * When a flash does not shine, there is a possibility that the flash unit is out of order. 4) Check a test result. * Results of the tests are usually NG. (When a result is OK, it is the completion of an inspection.) 5) When a result is NG, rewrite STB flag to an adjustment using ADJFLG → ALL F of ROM BACKUP. * The flag "STB" is an item which checks shines operation of a flash automatically at a Manufacturing facility. For this reason, except environment for exclusive use, a result will be NG. but it is no problem if shines operation can be checked visually.

Adjustment order	Adjustment Item	FLAG	Purpose	Replacing Parts							JIG/TOOLS	SET UP	How to Operate
				MAIN P.C.B./Flash-ROM/VENUS ENGINE	MAIN P.C.B. (When written Backup data)	Lens Part (Excluding Image Sensor)	Image Sensor	Microphone	Flash Part	Electronic Level (IC6201)			
13	MOS sensor Temp. white missing pixels *2	SKI	Registration of the Temp. white missing pixels	○	—	○	—	—	—	—	NONE	NONE	1) Change the flag into the "0", and then proceed to the adjustment mode. 2) Press the shutter button fully. (When a result is OK, it is the completion of an inspection.)
14	MOS sensor FD white missing pixels *2	WKI	Registration of the FD (floating diffusion) white missing pixels	○	—	○	*1	—	—	—	NONE	NONE	1) Change the flag into the "0", and then proceed to the adjustment mode. 2) Press the shutter button fully. (When a result is OK, it is the completion of an inspection.)
		BKI	Do not use "BKI" adjustment flag for this unit. Use "BK2" adjustment flag, instead. (In case of most DSC models, the adjustment flag for MOS SENSOR Missing Pixels is "BKI". But, in this model, "BK2" the adjustment flag for MOS SENSOR Missing Pixels.)										
15	Color reproduction inspection Microphone check	COL	Color reproduction inspection and Microphone check	○	—	○	○	○	—	—	NONE	NONE	1) Change the flag into the "0", and then proceed to the adjustment mode. 2) Press the shutter button fully. 3) Utter the voice for about 5 seconds into the microphone, just before pushing a shutter release. * Utter the voice at the above the LVF. * Comparatively high voice is ideal. (Standard: about 1KHz) (When a result is OK, it is the completion of an inspection.)
16	Electronic Level	AA2 + AA3	Electronic Level adjustment	○	○	—	—	—	—	○	—	* ACC Adjustment Chart	1) Download the "ACC Adjustment chart .pdf" and print it to A3 size (or equivalent size) paper. ("ACC Adjustment chart .pdf" is available at "TSN Website". To download, click on "Support information from NWBG/VDBG -AVC") 2) Hang in the string with weight, then put the printed ACC adjustment chart on the wall or panel horizontally. (Fig. 1) * After putting the adjustment chart horizontally, remove the string with weight. * Attach the camera to tripod. <Setup procedures> 3-1) Adjust the height of tripod to match the lens of camera and center of the adjustment chart. 3-2) Apply the triangle (or equivalent) in center of the chart, then adjust center of the lens of camera on the vertical extension. 3-3) Confirm that the chart is displayed on the LCD monitor fully. 3-4) Fine adjust the camera angle so that the horizontal bar of chart is displayed horizontally on the LCD monitor and matches the cross guide line of the LCD monitor. (Fig. 2) 1) Change the flag "AA2" and "AA3" into the "0", and then press DISPLAY button and proceed to the adjustment mode. <Offset adjustment-> 2) Set the camera to the horizontal position. Then set the distance between adjustment chart and camera body becomes 28 cm. And optical axis of the lens and center of the chart crosses right-angled. (Fig. 3) 3) Press the shutter button fully. (When a result is OK, it is the completion of an inspection.) <Tilt adjustment-> 4) Rotate the camera to the 90 degrees, so that the grip side down, and press the shutter button. (Fig. 4) 5) Set the camera to the horizontal position, and press the shutter button. (Fig. 5) 6) Rotate the camera to the 90 degrees, so that the grip side up, and press the shutter button. (Fig. 6) (When a result is OK, it is the completion of an inspection.)

Fig. 1:
Setting of the adjustment chart horizontally

Fig. 2:
Setting of the camera to the front of adjustment chart

Fig. 3:
[Offset]
(Horizontal Position)

Fig. 4:
[Vertical Position]
(Grip side Down)

Fig. 5:
[Horizontal Position]

Fig. 6:
[Vertical Position]
(Grip side Up)

Adjustment order	Adjustment Item	FLAG	Purpose	Replacing Parts							JIG/TOOLS	SET UP	How to Operate	
				MAIN P.C.B./Flash-ROM/VENUS ENGINE	MAIN P.C.B. (When written Backup data)	Lens Part (Excluding Image Sensor)	Image Sensor	Microphone	Flash Part	Electronic Level (IC6201)				Eye Sensor
17	Shading Compensation and MOS SENSOR Missing Pixels (Black) *3	BK2	Compensation of Shading and Compensation of MOS SENSOR Missing Pixels (Black)	O	-	O	*O	-	-	-	-	<ul style="list-style-type: none"> • Light Box RFKZ0523 • Diffuser RFKZ0591 	1) Set the Diffuser to diffusing surface of light box.	<ol style="list-style-type: none"> 1) Change the flag into the "0", and then proceed to the adjustment mode. (BK2 flag is 2nd pages.) 2) Press the shutter button fully. → Green ● mark is displayed on LCD. 3) Attach the Camera Lens on the Diffuser. And set the camera angle so that the diffusing surface of light box is displayed on the full of LCD monitor, and press the shutter button fully. → The 1st adjustment is executed, and then Green ● mark is displayed on LCD. 4) Separate the camera body from light box, and press the shutter button fully. → The lens starts zooming and stops automatically, then green ● mark is displayed on LCD. 5) Attach the Camera Lens on the Diffuser. And set the camera angle so that the diffusing surface of light box is displayed on the full of LCD monitor, and press the shutter button fully. → The 2nd adjustment is executed, and then Green ● mark is displayed on LCD. 6) Separate the camera body from light box, and press the shutter button fully. → The lens starts zooming and stops automatically, then green ● mark is displayed on LCD. 7) Attach the Camera Lens on the Diffuser. And set the camera angle so that the diffusing surface of light box is displayed on the full of LCD monitor, and press the shutter button fully. → The 3rd adjustment is executed. When a result is OK, it is the completion of an inspection.
	Wi-Fi check	WiFi	Do not use "WiFi" adjustment flag for servicing. This adjustment is for factory procedure. (For confirmation of Wi-Fi function, use the reception of Wi-Fi access point as usual.)											

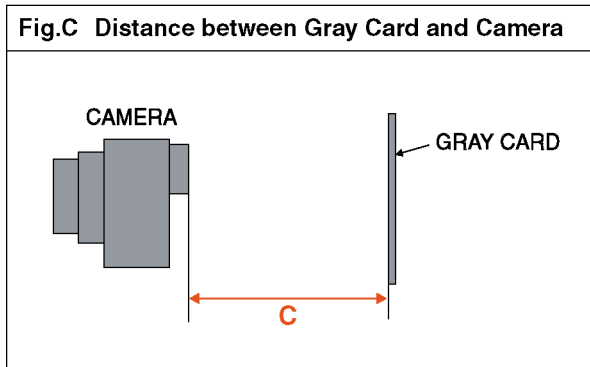
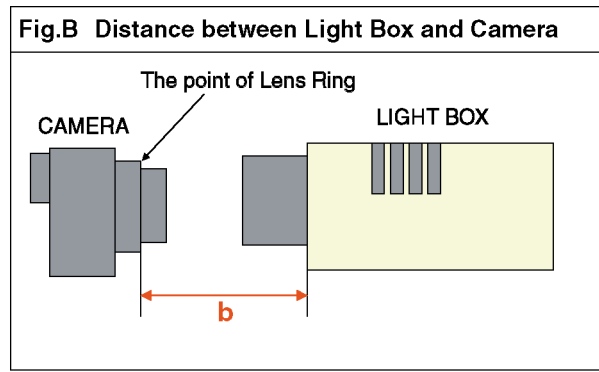
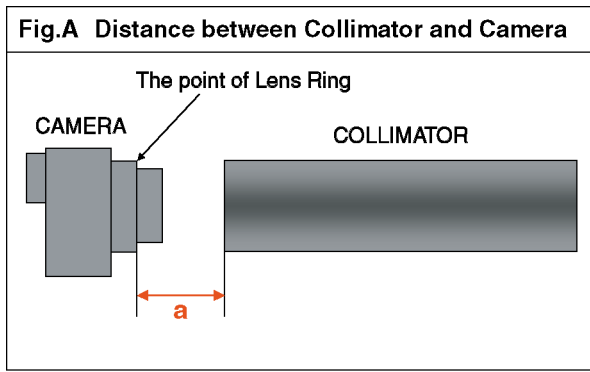

- *1. This adjustment must be performed not only replacing the MOS unit, but also simply removing the MOS unit.
- *2. The pixel that always lights while shaded is called a white wound.
- *3. The pixel that does not light while complete exposed is called a black wound.

IMPORTANT NOTICE: (After replacing the Main P.C.B. (Venus Engine is included) or Venus Engine)

After replacing the Main P.C.B. (Venus Engine is included) or Venus Engine, make sure to perform the "Initial Settings" first, then release the "Initial Settings" in order to proceed the electrical adjustment.

NOTE:

1. If electrical adjustment or data re-writing is executed before "Initial Settings", suffix code list is never displayed, and it cannot be chosen suitable suffix code.
2. Never remove the battery during initial setting in process.

10.4. After Adjustment

10.4.1. Initial Setting

Since the initial setting has been released to execute the built-in adjustment software, it should be set up again before shipping the camera to the customer.

Refer to the procedure described in "3.5.2. Initial Settings" for details.

[IMPORTANT]

1. The initial setting should be done again after completing the alignment. Otherwise, the camera will not work properly.
Therefore as a warning, the camera display a warning symbol " ! " on the LCD monitor every time the camera is turned off.
2. Confirm that status of all adjustment flag show "F". Even if one of the adjustment flag shows "0", initial setting programmed is never executed.

11 Maintenance

11.1. Cleaning Lens and LCD Panel

Do not touch the surface of lens and LCD Panel with your hand.

When cleaning the lens, use air-blower to blow off the dust.

When cleaning the LCD Panel, dampen the lens cleaning paper with lens cleaner, and the gently wipe the its surface.

Note:

The Lens Cleaning Kit ; VFK1900BK (Only supplied as 10 set/Box) is available as Service Aid.

12 Block Diagram

12.1. Overall Block Diagram

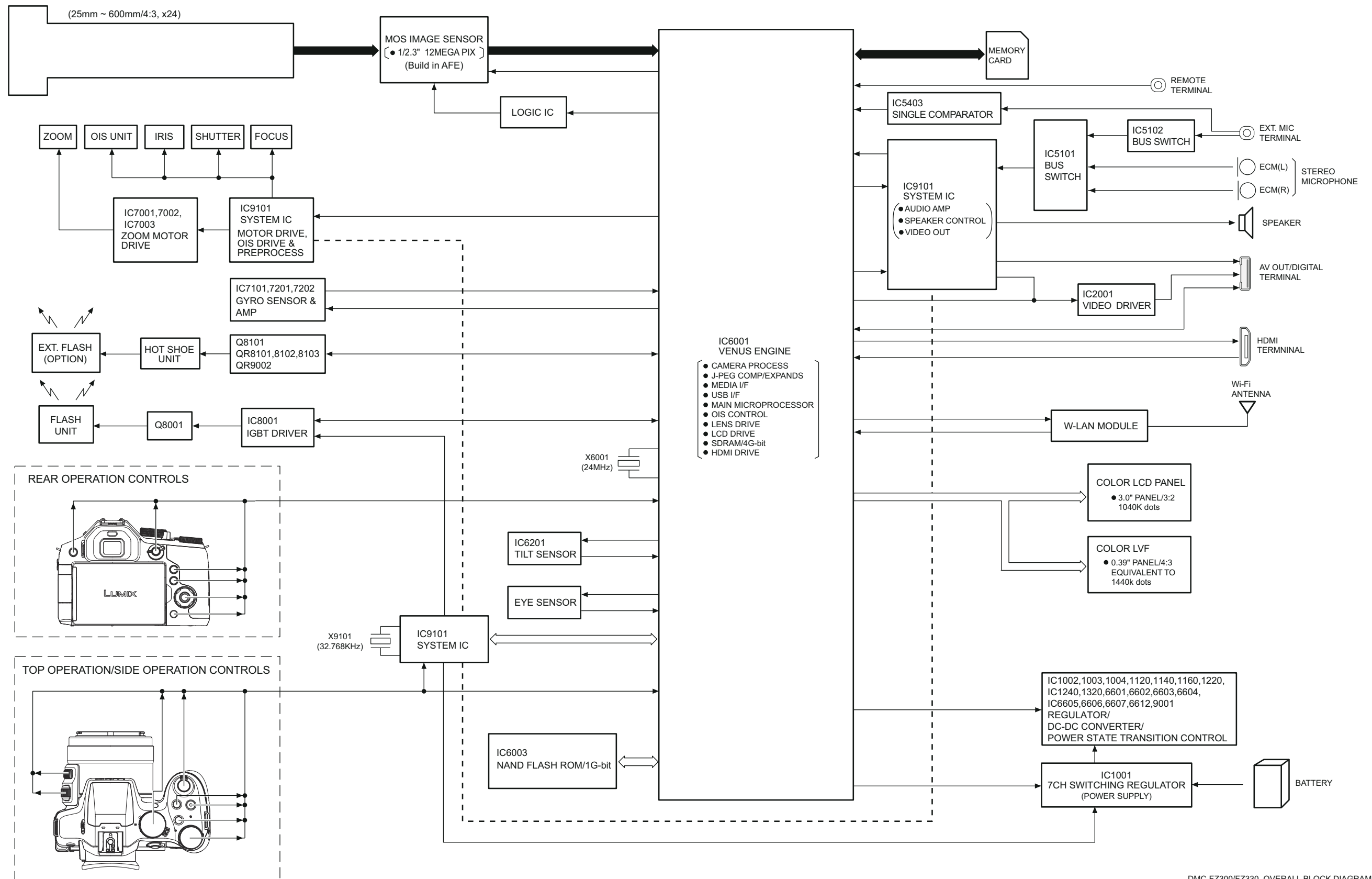

DMC-FZ300/FZ330 OVERALL BLOCK DIAGRAM

12.2. System Control Block Diagram

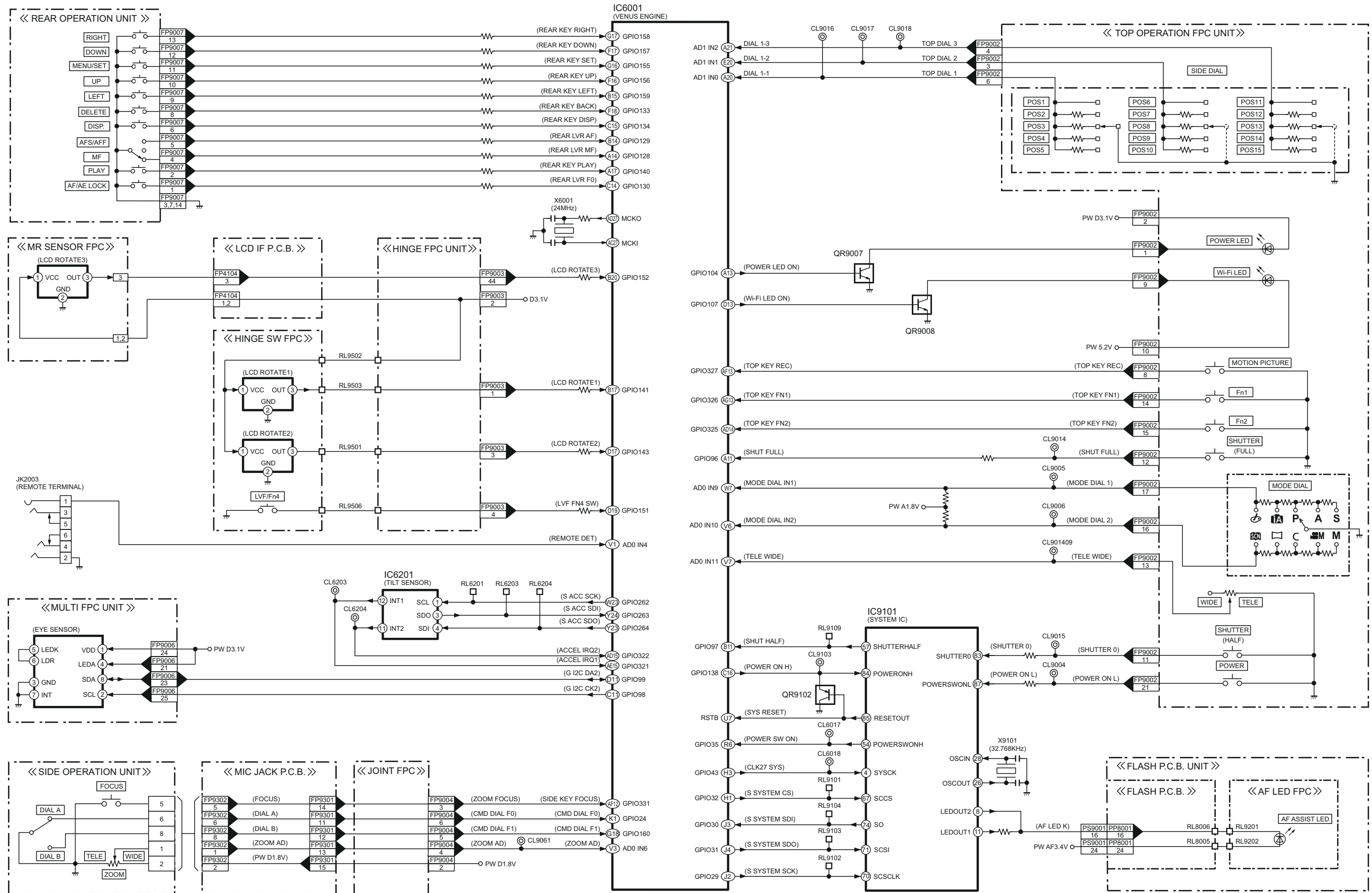

DMC-FZ300/FZ330 SYSTEM CONTROL BLOCK DIAGRAM

12.3. Video/Audio Process(1) Block Diagram

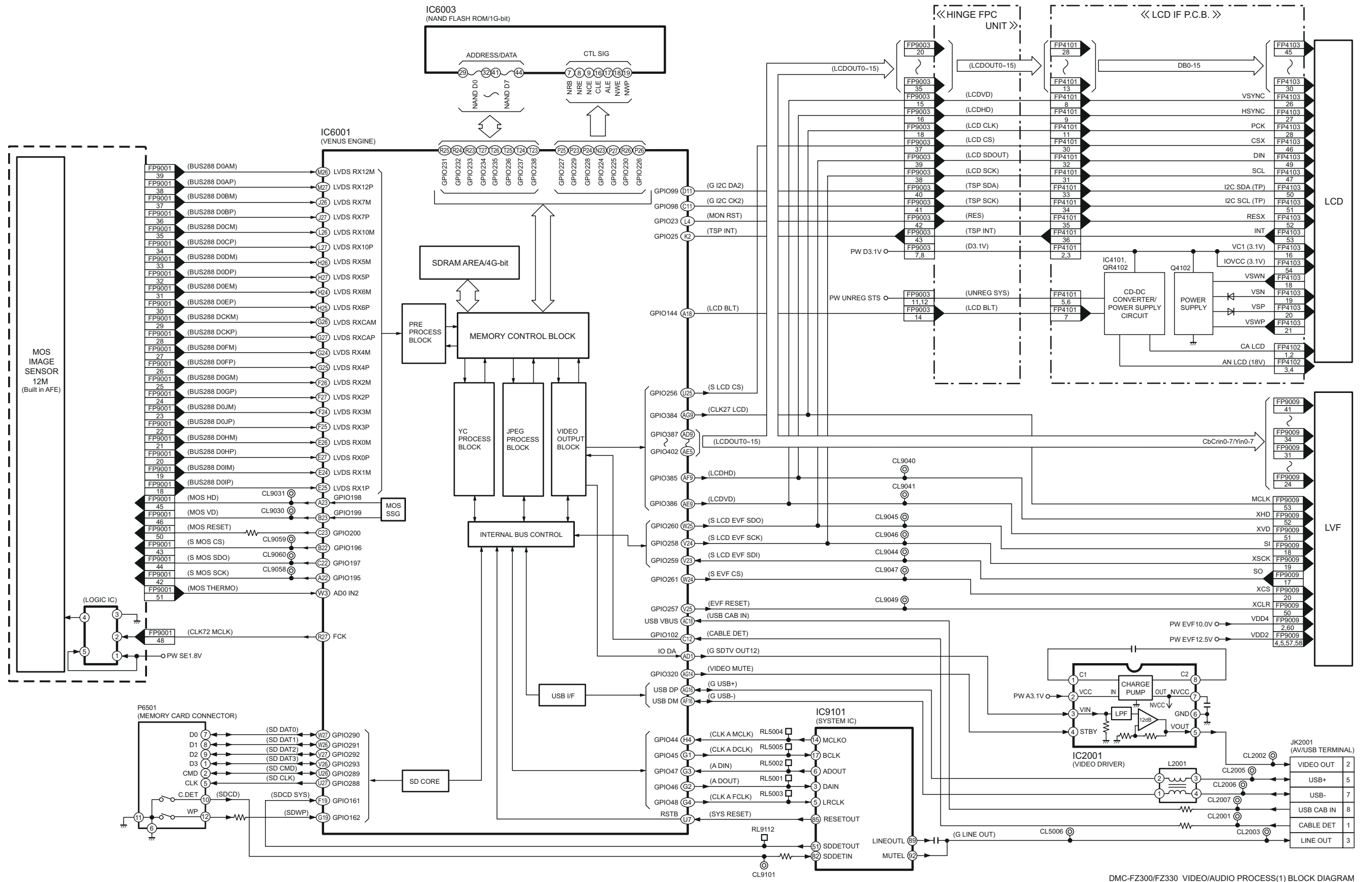

DMC-FZ300/FZ330 VIDEO/AUDIO PROCESS(1) BLOCK DIAGRAM

12.4. Video/Audio Process(2) Block Diagram

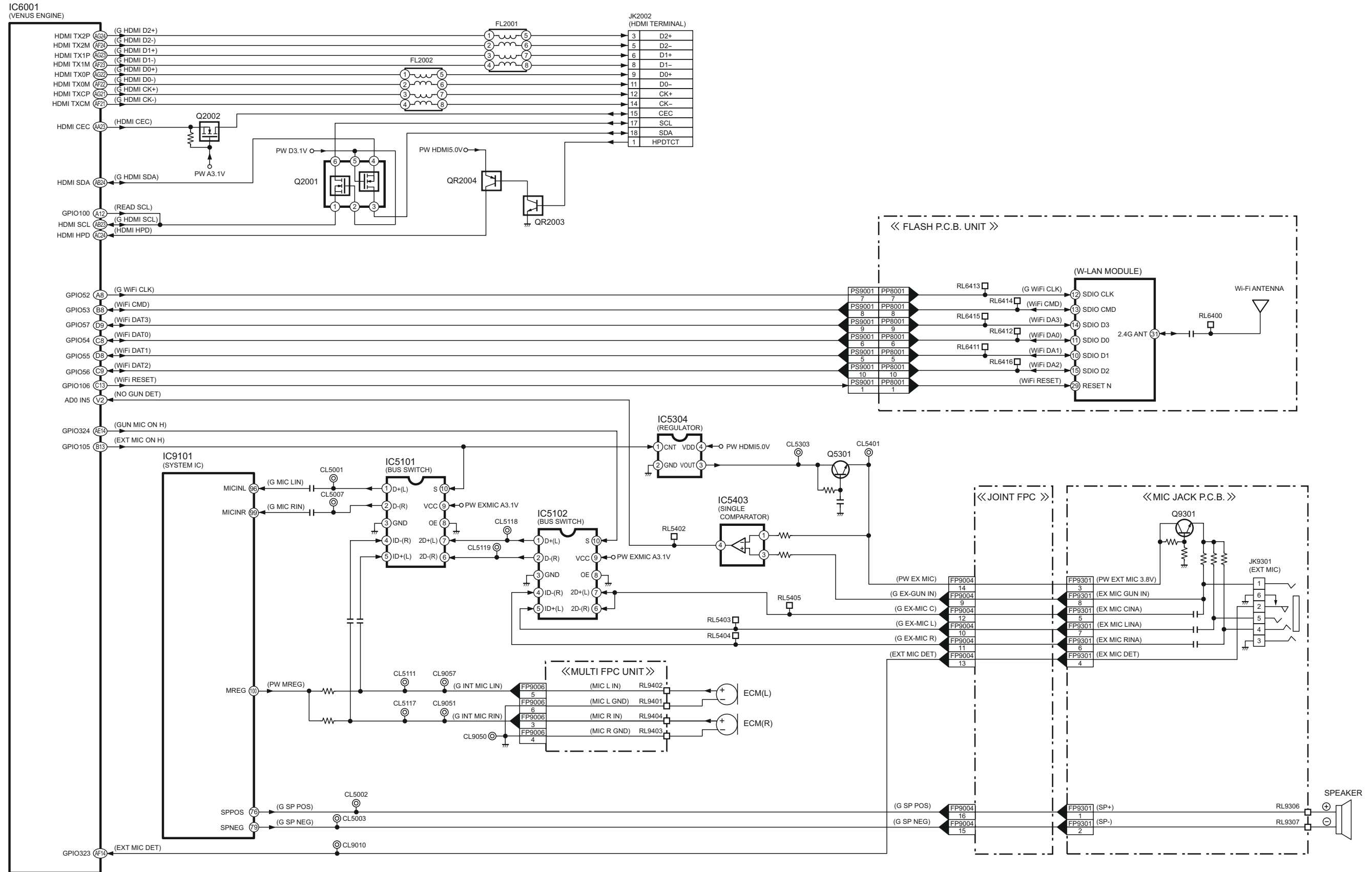

DMC-FZ300/FZ330 VIDEO/AUDIO PROCESS(2) BLOCK DIAGRAM

12.5. Lens/Flash Block Diagram

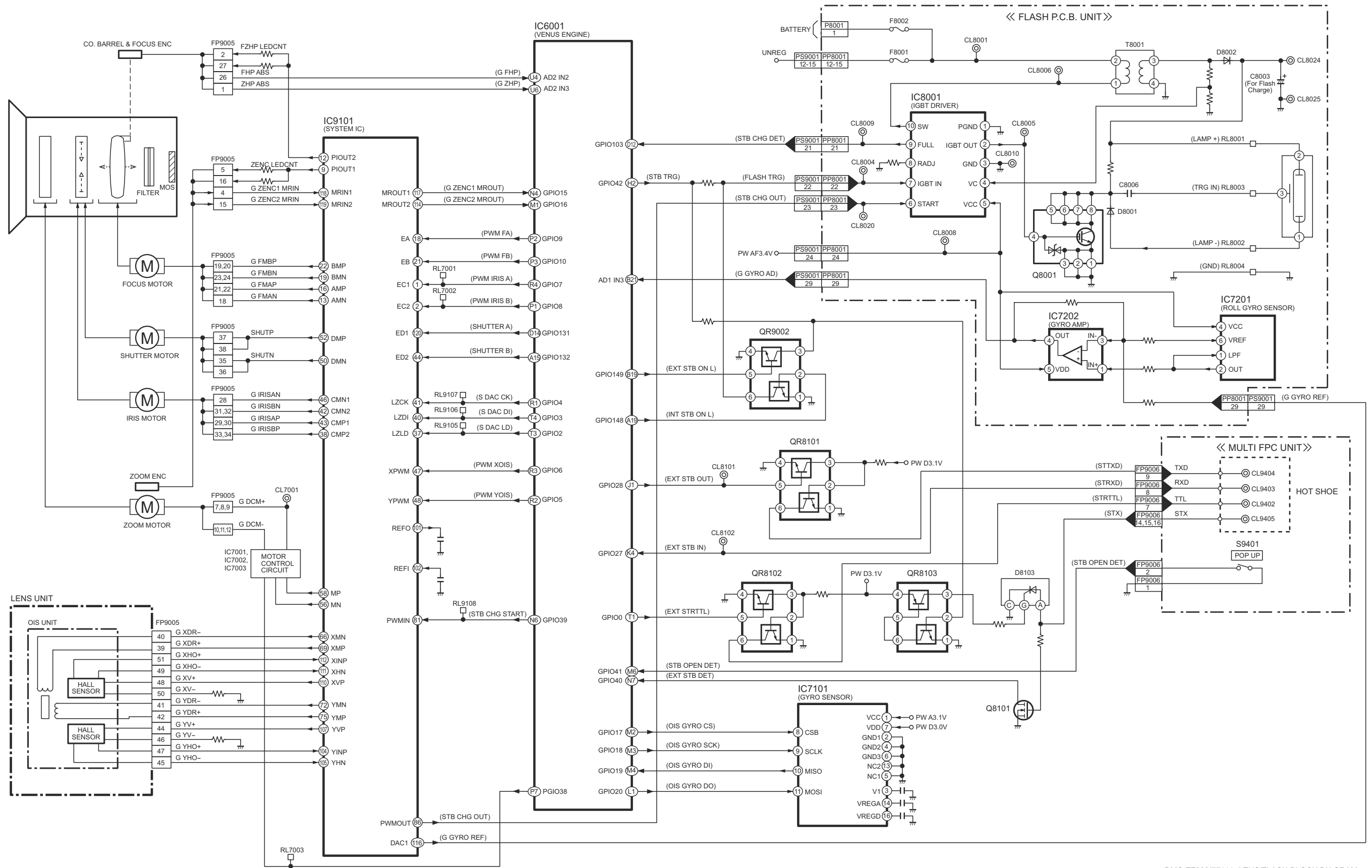

DMC-FZ300/FZ330 LENS/FLASH BLOCK DIAGRAM

12.6. Power(1) Block Diagram

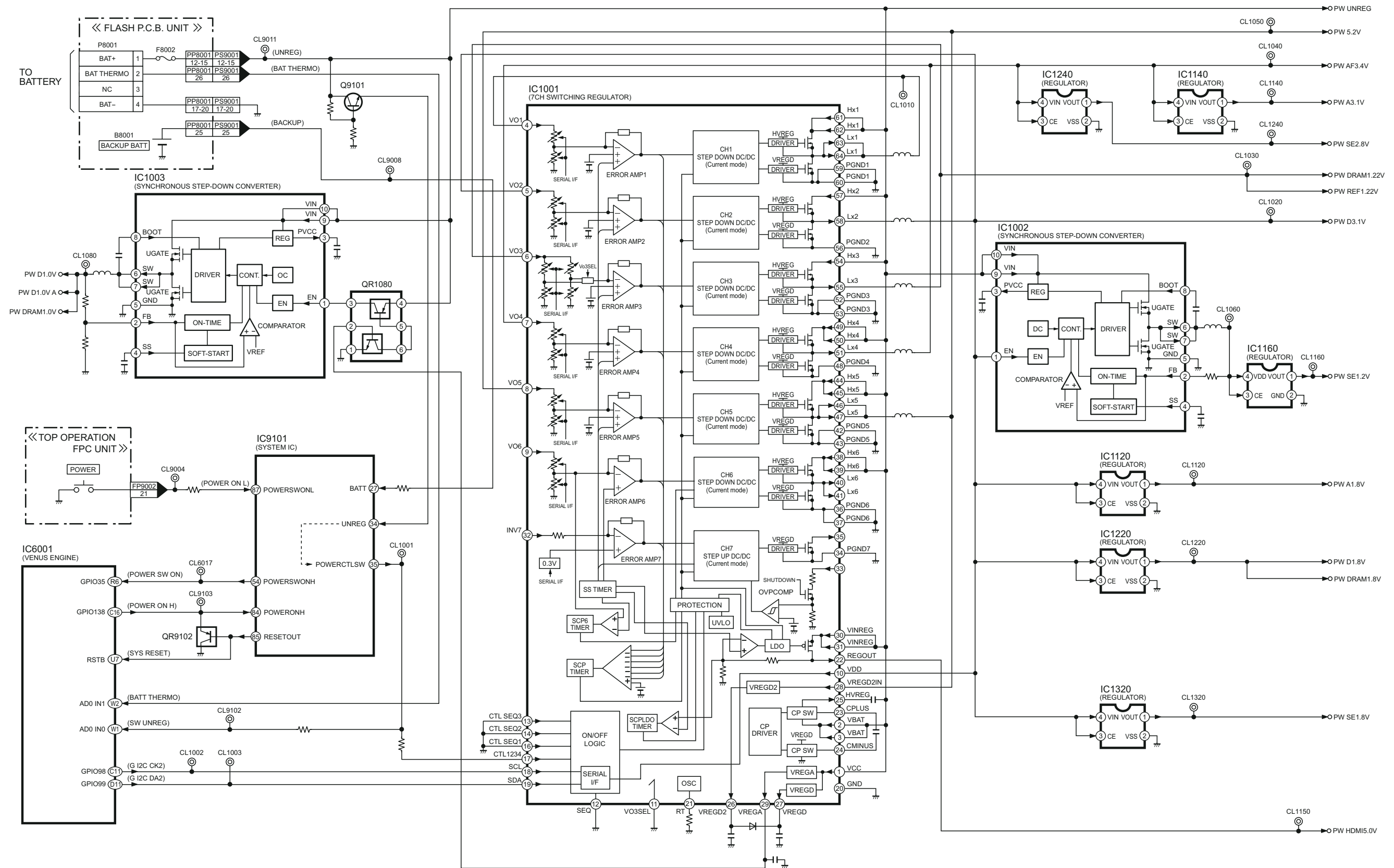

DMC-FZ300/FZ330 POWER(1) BLOCK DIAGRAM

12.7. Power(2) Block Diagram

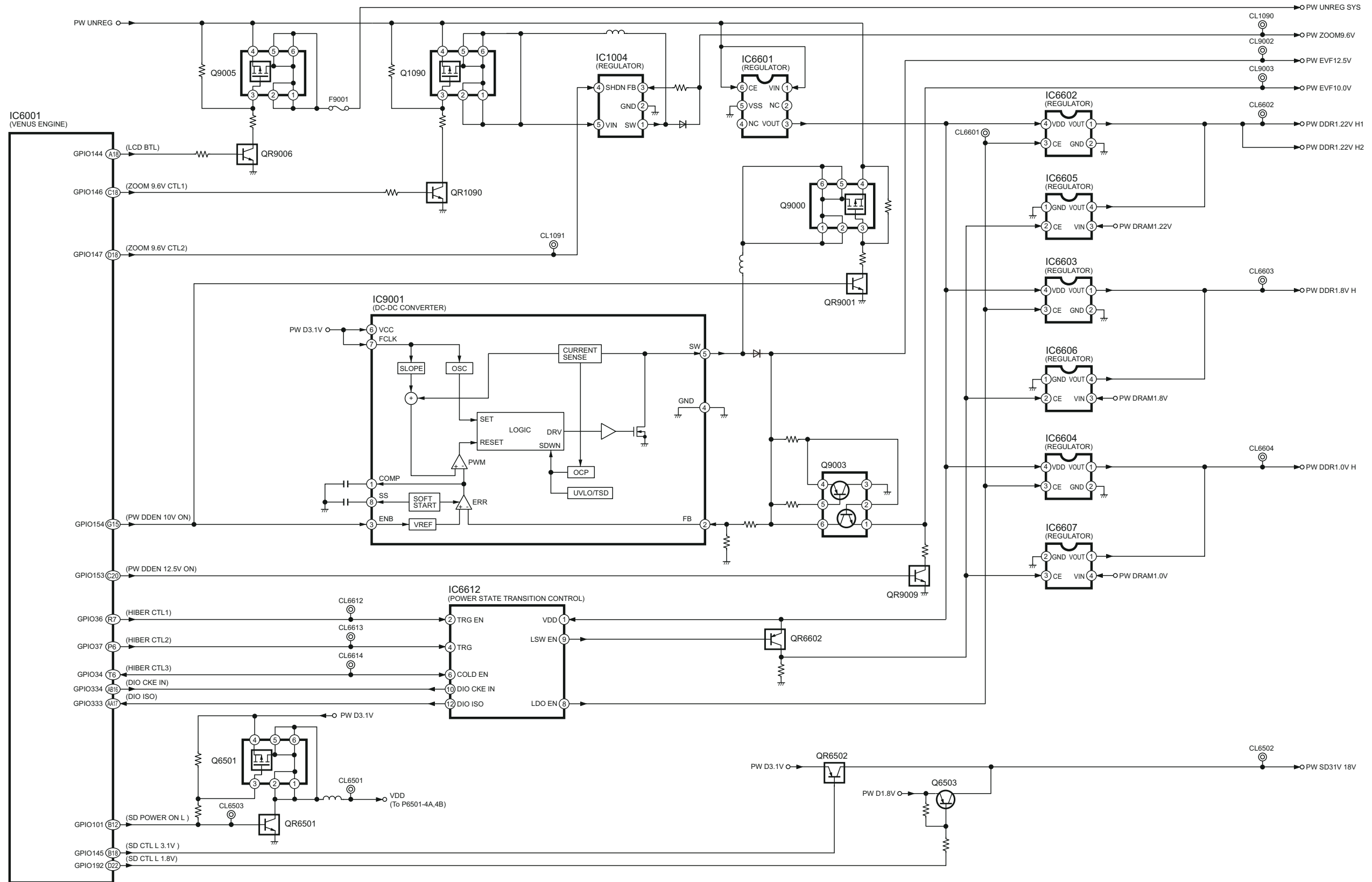

DMC-FZ300/FZ330 POWER(2) BLOCK DIAGRAM

13 Wiring Connection Diagram

13.1. Interconnection Diagram

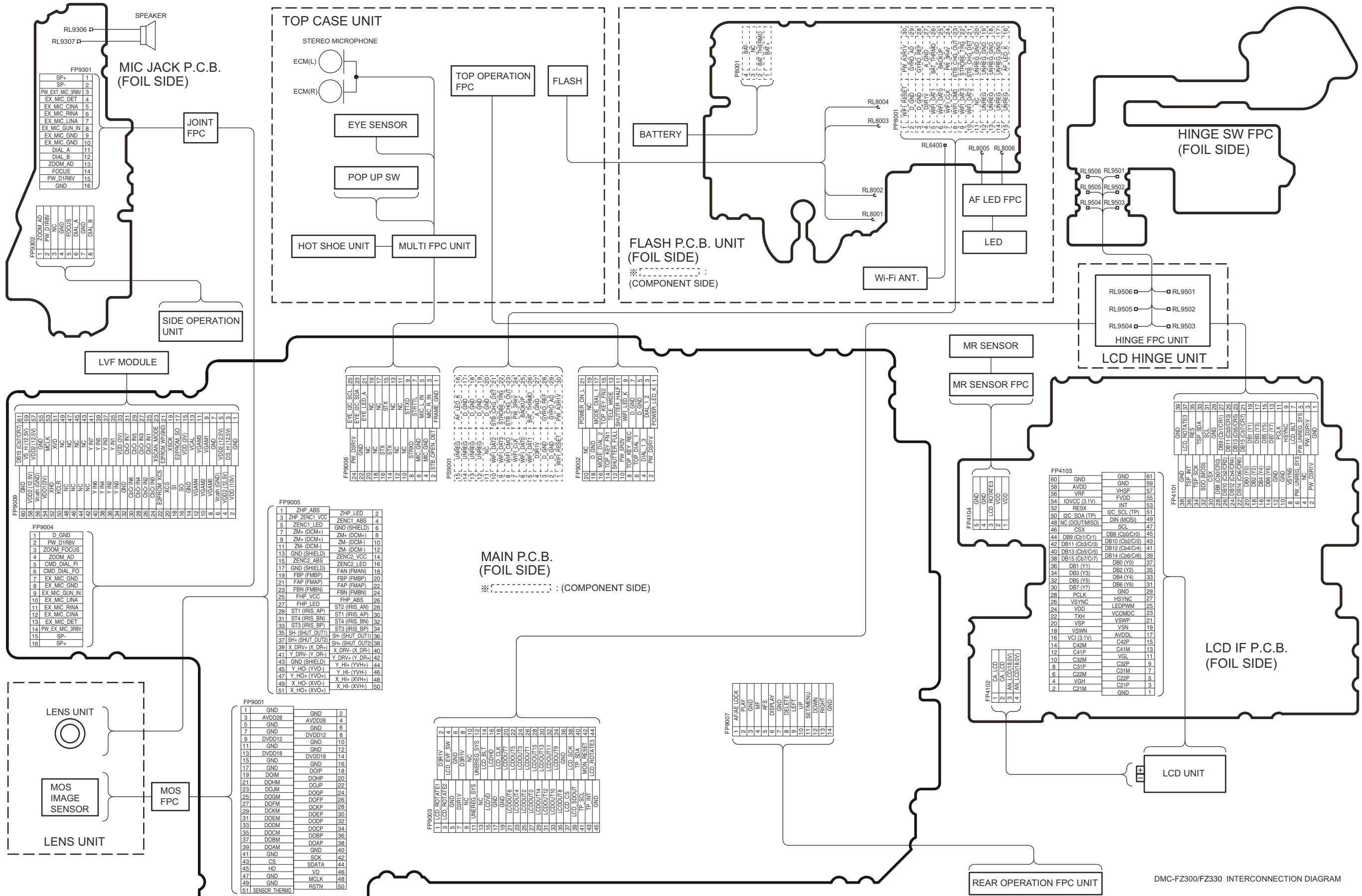

14 Schematic Diagram

Please click the radio button for "Diagrams II / Parts List" on the menu bar in XML Service Manual.
If you want to print, please click the icon button for "Print" on the icon bar and select the item.

15 Printed Circuit Board

Please click the radio button for "Diagrams II / Parts List" on the menu bar in XML Service Manual.
If you want to print, please click the icon button for "Print" on the icon bar and select the item.

16 Exploded View and Replacement Parts List

Please click the radio button for "Diagrams II / Parts List" on the menu bar in XML Service Manual.
If you want to print, please click the icon button for "Print" on the icon bar and select the item.