



Vacuum Packaging Machine
Model VP-IT-0324
Item 21623
Instruction Manual



Revised - 04/07/2017



Toll Free: 1-800-465-0234
Fax: 905-607-0234
Email: service@omcan.com
www.omcan.com

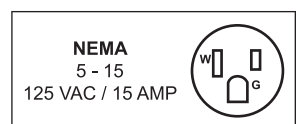

Table of Contents

Model VP-IT-0324

| Section | Page |
|--------------------------------|-------------|
| General Information ----- | 3 - 4 |
| Safety and Warranty ----- | 4 - 6 |
| Technical Specifications ----- | 6 - 7 |
| Operation ----- | 8 - 10 |
| Motor Diagram ----- | 10 |
| Figure Drawings ----- | 11 |
| Parts Breakdown ----- | 12 - 14 |
| Electrical Schematics ----- | 15 - 16 |
| Notes ----- | 17 - 18 |
| Warranty Registration ----- | 19 |



General Information

Omcan Manufacturing and Distributing Company Inc., Food Machinery of America, Inc. dba Omcan and Omcan Inc. are not responsible for any harm or injury caused due to any person's improper or negligent use of this equipment. The product shall only be operated by someone over the age of 18, of sound mind, and not under the influence of any drugs or alcohol, who has been trained in the correct operation of this machine, and is wearing authorized, proper safety clothing. Any modification to the machine voids any warranty, and may cause harm to individuals using the machine or in the vicinity of the machine while in operation.

CHECK PACKAGE UPON ARRIVAL

Upon receipt of an Omcan shipment please inspect for external damage. If no damage is evident on the external packaging, open carton to ensure all ordered items are within the box, and there is no concealed damage to the machine. If the package has suffered rough handling, bumps or damage (visible or concealed), please note it on the bill of lading before accepting the delivery and contact Omcan within 24 hours, so we may initiate a claim with the carrier. A detailed report on the extent of the damage caused to the machine must be filled out within three days, from the delivery date shown in the shipping documents. Omcan has no recourse for damaged products that were shipped collect or third party.

Before operating any equipment, always read and familiarize yourself with all operation and safety instructions.

Omcan would like to thank you for purchasing this machine. It's of the utmost importance to save these instructions for future reference. Also save the original box and packaging for shipping the equipment if servicing or returning of the machine is required.

Omcan Fabrication et distribution Compañie Limité et Food Machinery d'Amerique, dba Omcan et Omcan Inc. ne sont pas responsables de tout dommage ou blessure causé du fait que toute personne ait utilisé cet équipement de façon irrégulière. Le produit ne doit être exploité que par quelqu'un de plus de 18 ans, saine d'esprit, et pas sous l'influence d'une drogue ou d'acohol, qui a été formé pour utiliser cette machine correctement, et est vêtu de vêtements de sécurité approprié. Toute modification de la machine annule toute garantie, et peut causer un préjudice à des personnes utilisant la machine ou des personnes à proximité de la machine pendant son fonctionnement.

VÉRIFIEZ LE COLIS DÈS RÉCEPTION

Dès réception d'une expédition d'Omcan veuillez inspecter pour dommages externes. Si aucun dommage n'est visible sur l'emballage externe, ouvrez le carton afin de s'assurer que tous les éléments commandés sont dans la boîte, et il n'y a aucun dommage dissimulé à la machine. Si le colis n'a subi aucune mauvaises manipulations, de bosses ou de dommages (visible ou cachée), notez-le sur le bond de livraison avant d'accepter la livraison et contactez Omcan dans les 24 heures qui suivent, pour que nous puissions engager une réclamation auprès du transporteur. Un rapport détaillé sur l'étendue des dommages causés à la machine doit être rempli dans un délai de trois jours, à compter de la date de livraison indiquée dans les documents d'expédition. Omcan n'a aucun droit de recours pour les produits endommagés qui ont été expédiées ou cueilli par un tiers transporteur.

General Information

Avant d'utiliser n'importe quel équipement, toujours lire et vous familiariser avec toutes les opérations et les consignes de sécurité.

Omcan voudrais vous remercier d'avoir choisi cette machine. Il est primordial de conserver ces instructions pour une référence ultérieure. Également conservez la boîte originale et l'emballage pour l'expédition de l'équipement si l'entretien ou le retour de la machine est nécessaire.

Omcan Empresa De Fabricacion Y Distribucion Inc. Y Maquinaria De Alimentos De America, Inc. dba Omcan y Omcan Inc. no son responsables de ningun daño o perjuicio causado por cualquier persona inadecuada o el uso descuidado de este equipo. El producto solo podra ser operado por una persona mayor de 18 años, en su sano juicio y no bajo alguna influencia de droga o alcohol, y que este ha sido entrenado en el correcto funcionamiento de esta máquina, y ésta usando ropa apropiada y autorizada. Cualquier modificación a la máquina anula la garantía y puede causar daños a las personas usando la máquina mientras esta en el funcionamiento.

REVISE EL PAQUETE A SU LLEGADA

Tras la recepcion de un envio Omcan favor inspeccionar daños externos. Si no hay daños evidentes en el empaque exterior, Habra el carton para asegurarse que todos los articulos solicitados estén dentro de la caja y no encuentre daños ocultos en la máquina. Si el paquete ha sufrido un manejo de poco cuidado, golpes o daños (visible o oculto) por favor anote en la factura antes de aceptar la entrega y contacte Omcan dentro de las 24 horas, de modo que podamos iniciar una reclamación con la compañía. Un informe detallado sobre los daños causados a la máquina debe ser llenado en el plazo de tres días, desde la fecha de entrega que se muestra en los documentos de envío. Omcan no tiene ningun recurso por productos dañados que se enviaron a recoger por terceros.

Antes de utilizar cualquier equipo, siempre leer y familiarizarse con todas las instrucciones de operación y seguridad.

Omcan quisiera darles las gracias por la compra de esta máquina. Es de la máxima importancia para guardar estas instrucciones para referencias en el futuro. También guarde la caja original y el embalaje para envío del equipo si el mantenimiento o la devolución de la máquina es necesaria.

Safety and Warranty

Omcan is in continuous development of its products to improve technical, safety, ecological and commercial features; products could be different from this data sheet due to this nonstop improvement.

IMPORTANT SAFEGUARDS

When using electrical appliances, basic safety precautions should always be followed including the following:

1. Read all instructions.

Safety and Warranty

2. Do not operate any appliance with a damaged cord, plug, after the appliance malfunctions, is dropped or damaged in any manner. Return the unit to the nearest authorised service facility for examination, repair or electrical or mechanical adjustment.
 3. The use of attachments not recommended or sold by the manufacturer may cause fire, electric shock or injury.
 4. Do not use outdoors.
 5. Do not let the power cord hang over the edge of a table or counter.
 6. Household or light commercial use only, except where differently indicated.
 7. This appliance can be used by children aged from 8 years and above and persons with reduced physical, sensory or mental capabilities or lack of experience and knowledge **IF** they have been given supervision or instruction concerning use of the appliance in a safe way and understand the hazards involved.
 8. Acoustic level less than 60 dBA.
- Be careful during machine operation as heating elements are present on the welding bar.
 - Only use compatible bags for food preservation or those supplied with the unit.
 - Do not put the unit into water and do not use it if the plug or power cable are wet to avoid risks of fire or electric shock.
 - Do not overfill the bags to avoid risks of damage to the unit.
 - Carry out any operations on the unit (cleaning included) with the power cable disconnected from the socket to avoid risks of electric shock.
 - Vacuum packaging does not replace other preservation methods but it can be combined with them.
 - Perishable food requires cooling or freezing to prevent deterioration. Vacuum packaging prolongs preservation times and helps keep original quality of the food product.
 - Pre-packaged products must be used within the date indicated on packing.
 - A higher vacuum level corresponds to a lower oxygen quantity with resulting possibilities of better preservation.
 - Liquids shall be refrigerated before packaging to prevent them from leakage which can be sucked into the vacuum chamber.
 - Clean the vacuum chamber in case of liquids or powder. Make sure to let the vacuum chamber dry after cleaning.
 - To reduce risks of electric shock, this product must be connected to a grounded plug. If the socket does not fit the plug, contact a qualified electrician to install the proper outlet. Do not change the plug in any way.
 - Close supervision is required when this product is used near children.
 - Products in powder or grains shall be covered with a cloth before being vacuum-packaged so that they are not sucked into the vacuum chamber and do not obstruct the valve.
 - Containers unsuitable for vacuum packaging can implode through the effect of air pressure and cause damages and injuries. In case of storage in freezers, only special containers in toughened glass shall be used.
 - The air pump and the welding system are equipped with thermal protection: in case of overheating the unit stops automatically and can resume work after cooling.
 - Experience and practice will enable you to obtain the best results with each product.
 - Wrinkles and creases on the bag surface can prevent the package from reaching a satisfactory vacuum level. To avoid such inconveniences, place the bag in spread conditions within the vacuum chamber.
 - Adjustments related to operation are to be carried out by the manufacturer or authorised technician, both for safety and reliability purposes.

Safety and Warranty

- If you have not waited for the minimum time prescribed between connection and cycle starting, act as follows: unplug, plug again and wait as long as required.
- When containers are used particular attention should be paid to welding bar heating to prevent burns.
- For safety reasons, we recommend to operate manually when containers are used and the vacuum gauge pointer reaches the limit of the yellow area.
- If the power cable is damaged in any way, have it replaced by a qualified electrician with the same type of cable.
- With practice and experience you will be able to obtain the best results from the machine with any different kind of food.

1 YEAR PART AND LABOUR BENCH WARRANTY

Within the warranty period, contact Omcan Inc. at 1-800-465-0234 to schedule a drop off to either an Omcan authorized service depot in the area, or to an Omcan Service warehouse to repair the equipment.

Unauthorized maintenance will void the warranty. Warranty covers electrical and part failures, not improper use.

Please see www.omcan.com/warranty.html for complete info.

WARNING:

The packaging components are classified as normal solid urban waste and can therefore be disposed of without difficulty.

In any case, for suitable recycling, we suggest disposing of the products separately (differentiated waste) according to the current norms.

DO NOT DISCARD ANY PACKAGING MATERIALS IN THE ENVIRONMENT!

Technical Specifications

| | |
|-------------|---------------------------------------|
| Model | VP-IT-0324 |
| Seal Bar | 12.8" / 324mm |
| Power | 180 W |
| Electrical | 110V/60/1 |
| Weight | 7 lbs. / 3.2 kgs. |
| Dimensions | 6.5" x 15" x 4.3" / 165 x 381 x 108mm |
| Item Number | 21623 |

Technical Specifications

- LED displaying vacuum level.
- Welding bar 32 cm. (for bags of 30 cm.).
- Continuous duty.
- Power cord storing compartment. Air intake for container coupling.
- Max. absorbed power: 250 W.
- Max. vacuum level: -830 mbar.
- Aspiration capacity: 16 l./min.
- Included in the package: 20 bags cm. 20 x 30 (6722 A)

| Food Product | Preservation Under Normal Conditions (No. of Days) | Preservation Using Vacuum (No. of Days) |
|---|--|---|
| Environmental temperature (+20° / +25° C) | | |
| Bread | 2 | 8 |
| Dry biscuits | 120 | 360 |
| Dry pasta / rice | 180 | 360 |
| Dried fruit | 120 | 360 |
| Flour / Tea / Coffee | 120 | 360 |
| Refrigerated at temperatures of +3° / +5° C | | |
| Raw meat | 2 - 3 | 6 - 9 |
| Fresh fish | 1 - 3 | 4 - 6 |
| Sausage products | 4 - 6 | 20 - 25 |
| Soft cheese | 5 - 7 | 14 - 20 |
| Hard cheese | 15 - 20 | 30 - 60 |
| Parmesan | 20 | 60 |
| Raw vegetables | 1 - 5 | 7 - 20 |
| Fresh Fruit | 5 - 10 | 14 - 20 |
| Minestrone Soup | 2 - 3 | 6 - 10 |
| Cooked course | 2 - 3 | 6 - 10 |
| Cooked meat | 3 - 5 | 10 - 15 |
| Desserts with cream or fruit | 2 - 3 | 6 - 10 |
| Other desserts | 5 | 20 |
| Frozen at -18° / -20° C | | |
| Meat | 120 | 480 |
| Fish | 90 | 360 |
| Fruits and vegetables | 300 | 720 |

CAUTION

These preservation periods are only a guideline and will depend upon the initial condition and freshness of the food and the cooking method. Pre-packed foods must be used within the “best before” date indicated on the packaging.

Operation

USE OF THE MACHINE

All numbers in brackets (#) refer to those listed in the “Figure Drawing” section of the manual on page 11. Plug the machine in, making sure the socket has suitable voltage for the unit. The unit is now ready for operation. Press switch (1) to start the air pump and air suction. Press the switch again to stop the unit. When the air pump is working, press switch (2) to operate the welding bar until the automatic relay switch on. The unit stops automatically after a pre-determined time or by pressing the on/off switch. The green LED (4) also acts as welding time meter: during welding it flashes as many times as the number of seconds set. The red LED lights up when a sufficient vacuum level has been achieved. Nevertheless welding can be postponed to reach a higher vacuum level; this operation does not cause any damage to the unit.

CHANGING THE DEFAULT SETTINGS

SEALING TIME

To change the sealing power set, proceed as follows:

- Connect the appliance to the electrical mains.
- Press and release the sealing button (2) 10 times within 10 seconds; the green led, if on the model, will quickly flash to indicate you entered programming mode.
- If the green led is not flashing, it means the first part of programming is not correctly executed.
- Press and release the running button (1) as many times as the desired time/power unit; the green led, if on the model, flashes on each impulse.
- If the running switch is pressed for the first time (1) and the appliance starts the suction function, switch off the machine and repeat the programming procedure.
- Wait 10 seconds without pressing the buttons or disconnect the appliance from the electrical mains, (by doing so, the settings are saved).

Be careful! Don't set more than 9 seconds or the Teflon protection of the sealing bar can burn.

TO SET TO DEFAULT AGAIN

- Press and keep pressed the two switches.
- Connect the unit.

TO CHANGE FROM THE AUTOMATIC TO MANUAL USE

- Disconnect the unit.
- Press and keep pressed the start switch.
- Connect the unit.
- Wait the green LED light.

TO CHANGE FROM THE MANUAL TO AUTOMATIC USE

- Disconnect the unit.
- Press and keep pressed the seal switch.
- Connect the unit.
- Wait the green LED light.

VACUUM PACKAGING IN BAGS

Introduce the product into a bag suitable for vacuum food preservation; leave at least 3 cm free room from bag opening. Lift the cover (6) and place the bag (spread out well with no wrinkles) on the welding bar (9), on the left of the slide (11). Make sure that the open side of the bag is inserted in the vacuum chamber (8). Put the power cable into a socket and start the air pump by pressing switch (1). Slightly press your hands on the cover (6) to produce an initial depression in the vacuum chamber until the bag starts adhering to the product (pressing as long as vacuum packaging has been completed is not necessary). When the vacuum level is reached, the welding will start automatically. After welding the unit stops.

Cod. 9340 N – 9340 NAUS – 9340 NCSA– 9342 N (S-T-R-B): Push laterally the opening valve of the cover (7) to lift the cover and remove the bag.

Cod. 9346 N (F) – 9348 N (F): the opening of the cover is automatic. Before storing the bag, check that welding has been carried out correctly. No wrinkles capable of letting air in shall be present.

VACUUM LEVEL

The vacuum packaging unit is supplied with a vacuum sensor, installed in the electronic board, which makes a red LED light up when a certain vacuum level (varying between –680 mbar and –750 mbar) is reached. The vacuum level depends on the shape of bag content. It is possible to postpone welding to reach a higher vacuum level without causing any damage to the unit. The vacuum level which the unit can reach depends on food (or object) quality and shape. For example, a rigid structure of the material in the bag can produce air residuals that cannot be removed and will prevent the vacuum gauge from reaching the maximum level. There are also products (such as fish, tomatoes, etc.) containing liquids which, in case of compression, leak out and can be sucked by the machine with resulting damages. Other products that are not very compact can be damaged or crushed with an excessive vacuum level. We recommend checking the adherence of the bag and welding before operation.

OMCAN BAGS

| Item | Model | Description |
|-------|-------------|--|
| 10201 | VB150X300 | HD Vacuum Bags 6" × 12" - 1000/case |
| 21468 | VB150X300PK | HD Vacuum Bags 6" × 12" - 100/package |
| 10209 | VB200X300 | HD Vacuum Bags 8" × 12" - 1000/case |
| 21469 | VB200X300PK | HD Vacuum Bags 8" × 12" - 100/package |
| 10214 | VB250X350 | HD Vacuum Bags 10" × 13.75" - 1000/case |
| 21470 | VB500X350PK | HD Vacuum Bags 10" × 13.75" - 100/package |
| 10215 | VB250X400 | HD Vacuum Bags 10" × 16" - 1000/case |
| 21471 | VB250X400PK | HD Vacuum Bags 10" × 16" - 100/package |
| 10216 | VB250X450 | HD Vacuum Bags 10" × 18" - 1000/case |
| 21472 | VB250X450PK | HD Vacuum Bags 10" × 18" - 100/package |
| 10236 | VBR180X5000 | HD Vacuum Bags 7" × 200" - 2 rolls per box |

Operation

Call your local food equipment dealer to purchase additional bags.

REFERENCE

| Item Number | Model Number | Description | Manufacturer Model Number |
|-------------|--------------|--|---------------------------|
| 21623 | VP-IT-0324 | Vacuum Packaging Machine 13" / 324mm Seal Bar 110V/60/1 cTUVus | 9340N |

Motor Diagram

Model VP-IT-0324 21623

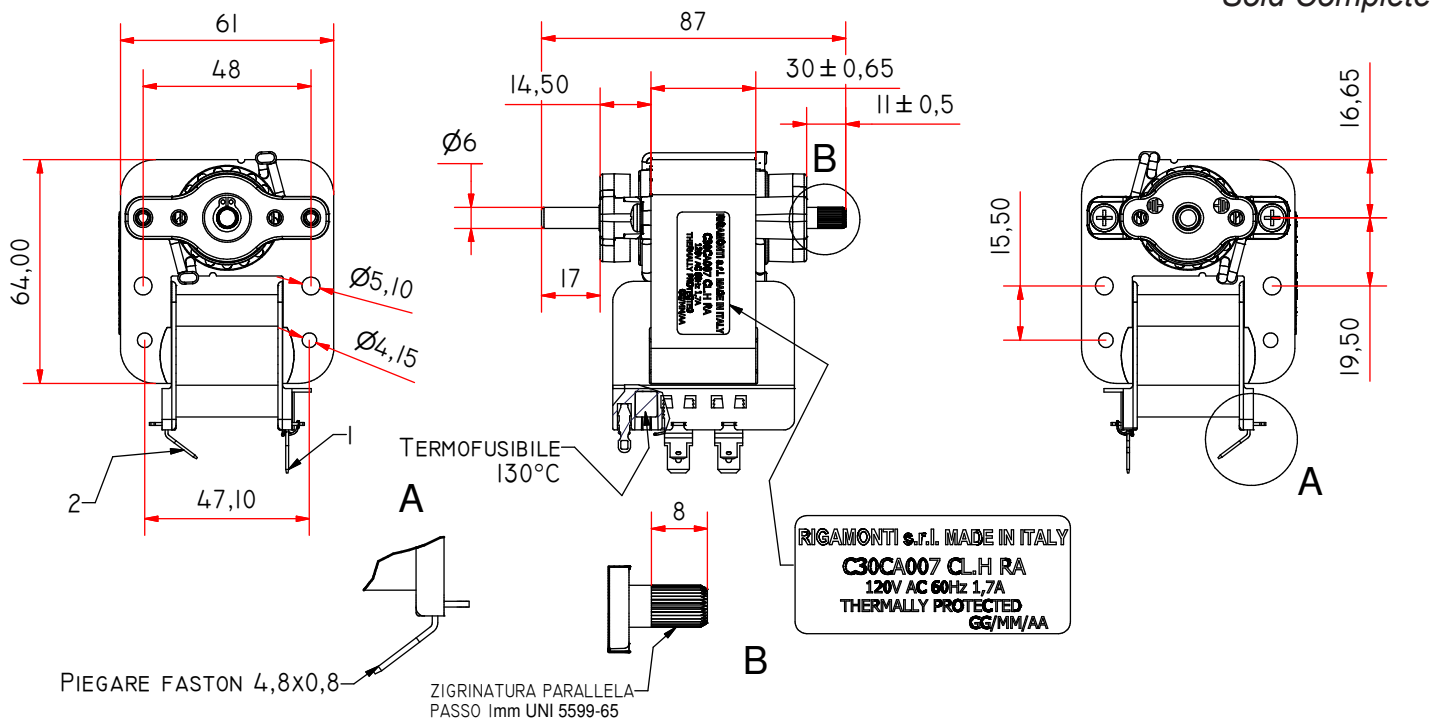

ALL NUMBERS REFER TO DIMENSIONS OF THE MOTOR IN MILLIMETERS.

Figure Drawings

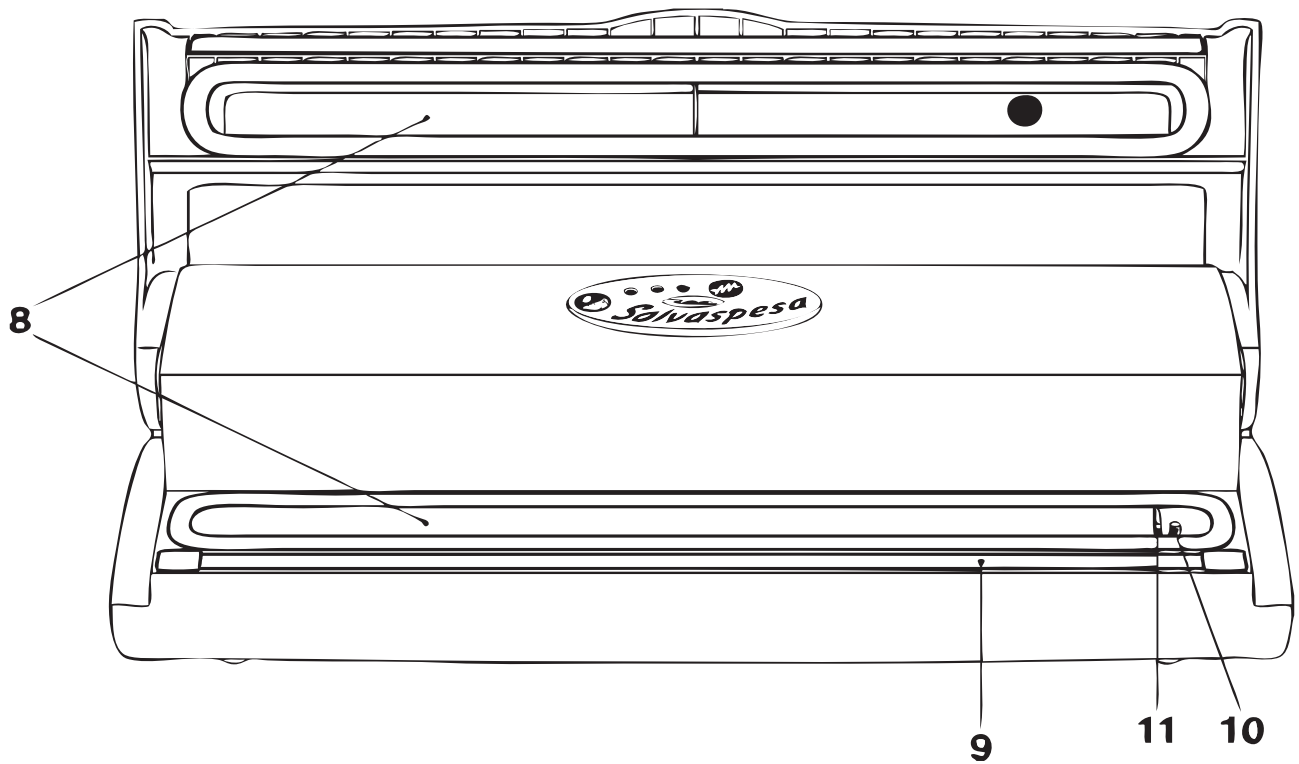
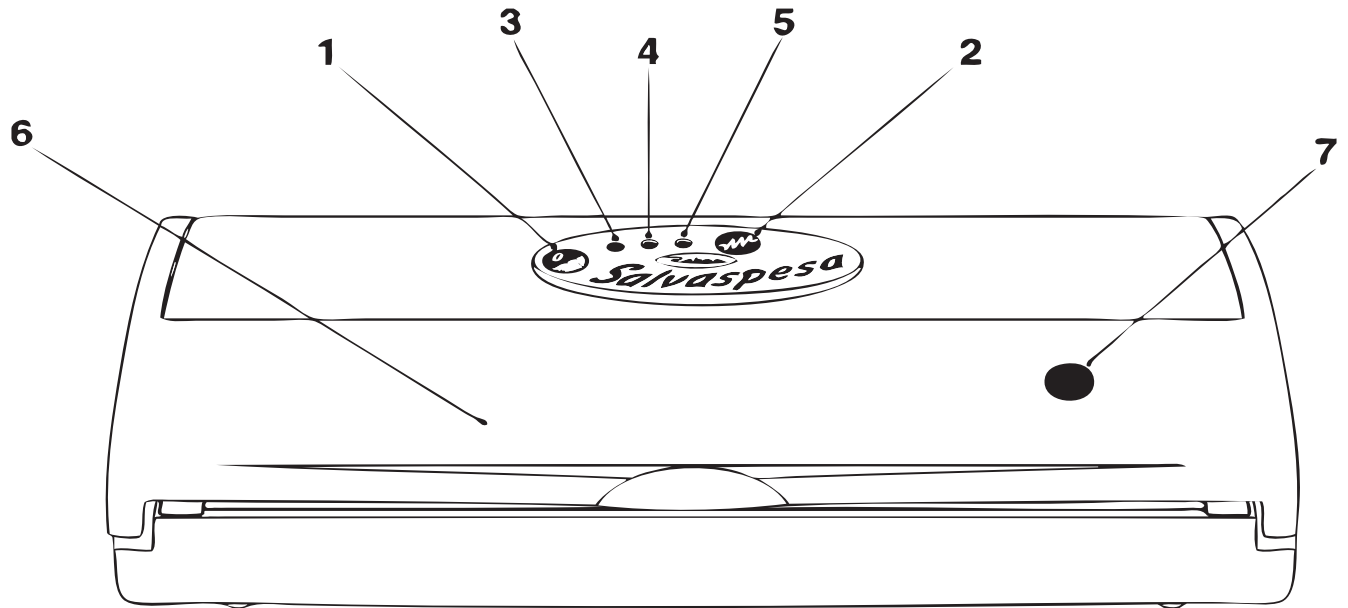

Parts Breakdown

Model VP-IT-0324 21623

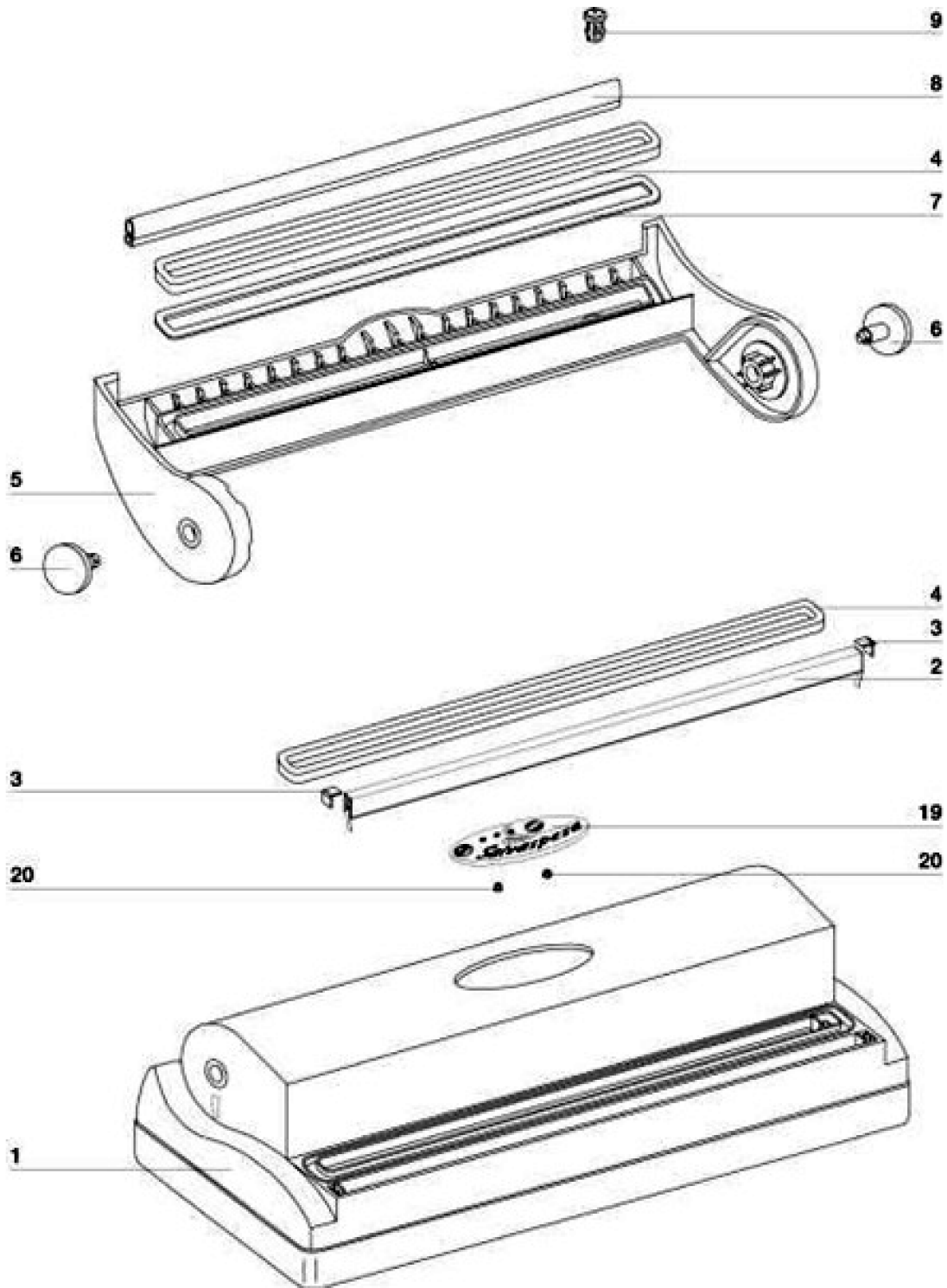

Parts Breakdown

Model VP-IT-0324 21623

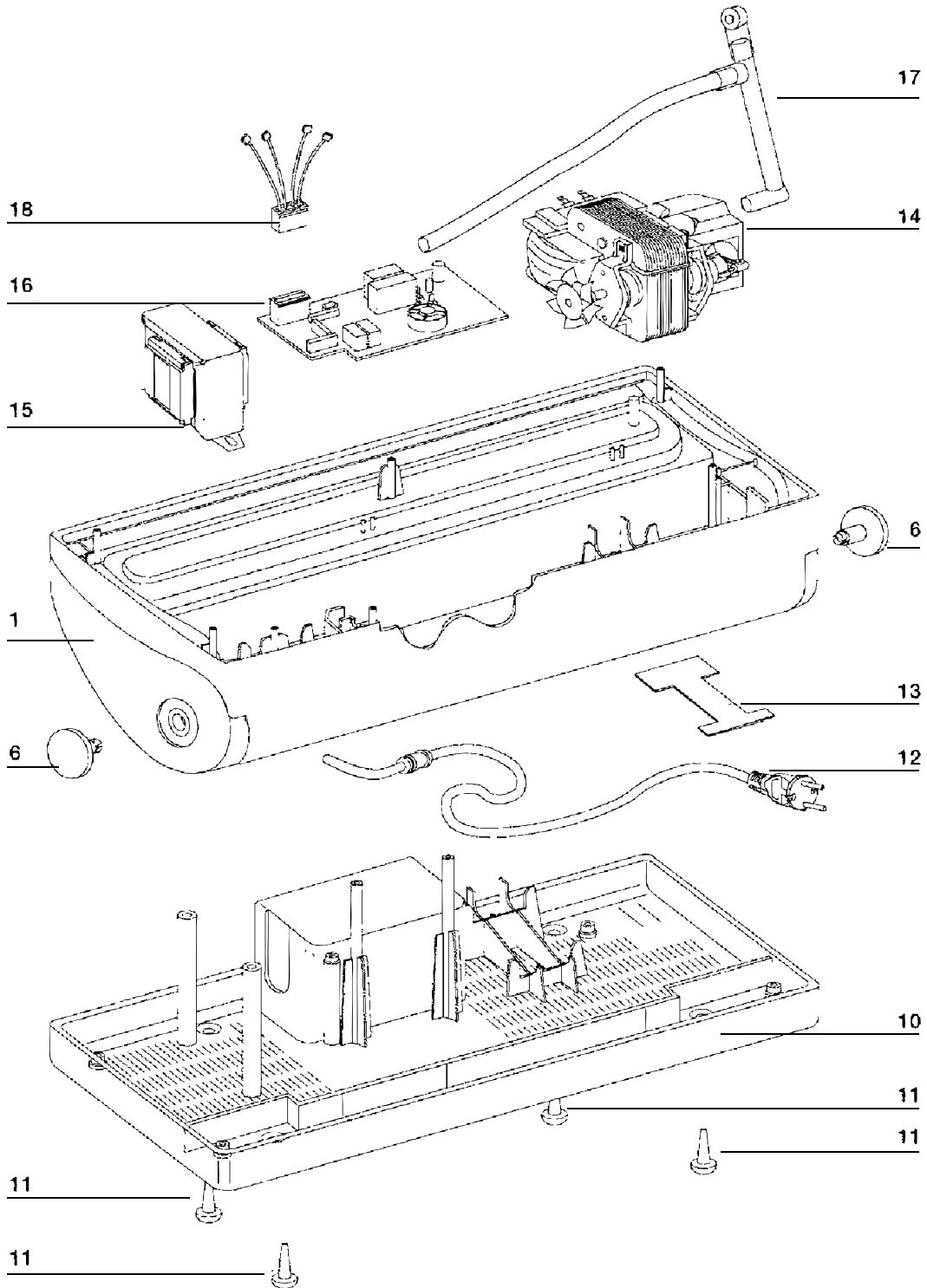

Parts Breakdown

Model VP-IT-0324 21623

| Item No. | Description | Position | Item No. | Description | Position | Item No. | Description | Position |
|----------|-----------------------------|----------|----------|---------------------------------|----------|----------|---------------------------------------|----------|
| 75271 | Housing Salvapesa for 9340N | 1 | 72249 | Top Bar for 9340N | 8 | 75278 | Transformer for 9340N | 15 |
| 72244 | Bottom Bar for 9340N | 2 | 72250 | Valve for 9340N | 9 | 75279 | Electronic Card for 9340N | 16 |
| 72245 | Socket for 9340N | 3 | 75273 | Base for 9340N | 10 | 75280 | Hose Kit Air for 9340N | 17 |
| 72246 | Gasket for 9340N | 4 | 75274 | Feet for 9340N | 11 | 75281 | Salvapesa Harness Connector for 9340N | 18 |
| 72247 | Cover for 9340N | 5 | 75275 | Cable Plug Salvapesa for 9340N | 12 | 41618 | Sealing Bar Complete for 9340N | |
| 75272 | Stopper for 9340N | 6 | 75276 | Pump Support for 9340N | 13 | | | |
| 72248 | Top Gasket for 9340N | 7 | 75277 | Vacuum Pump Salvapesa for 9340N | 14 | | | |

Electrical Schematics

Model VP-IT-0324 21623

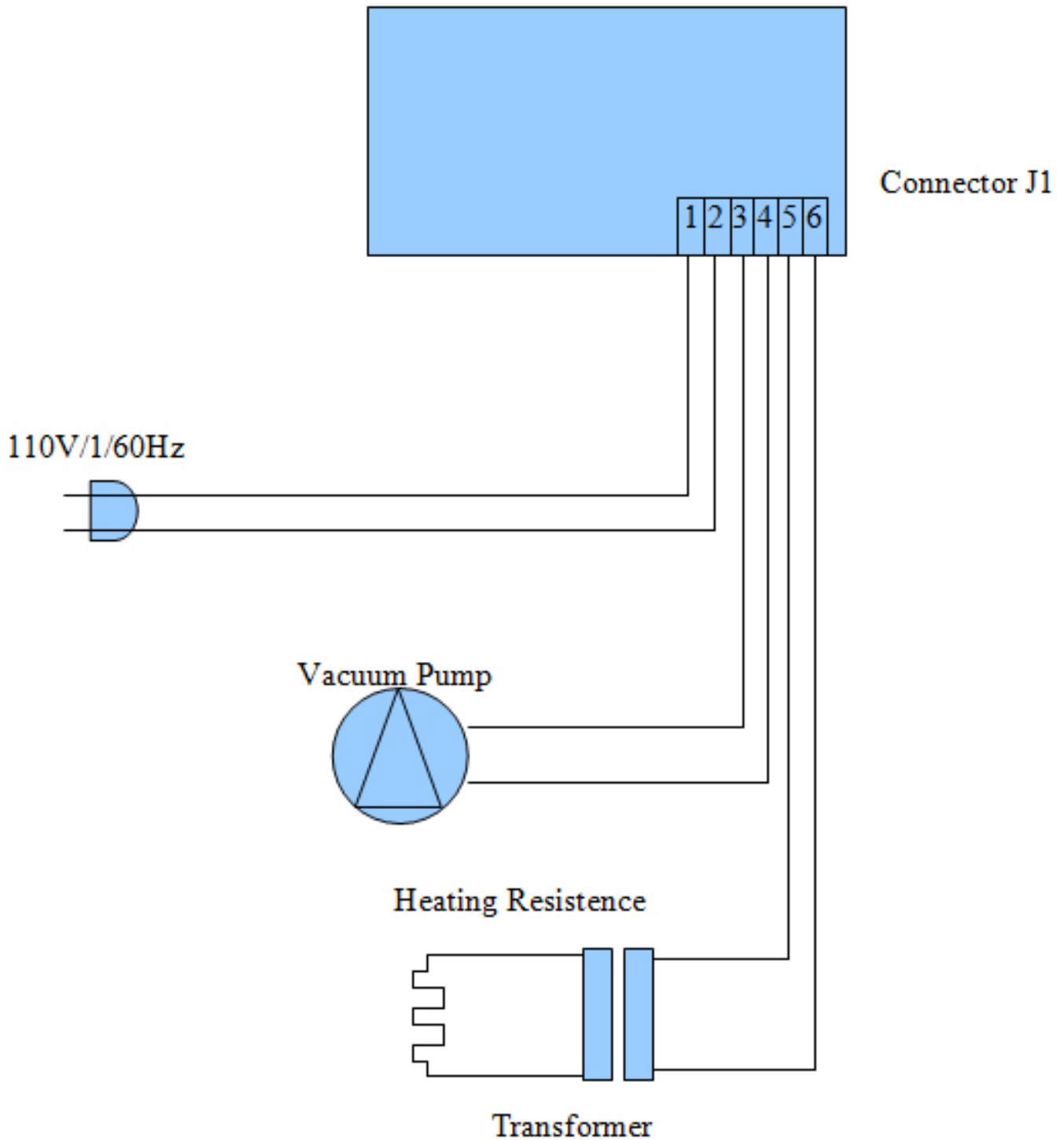

Electrical Schematics

Model VP-IT-0324 21623

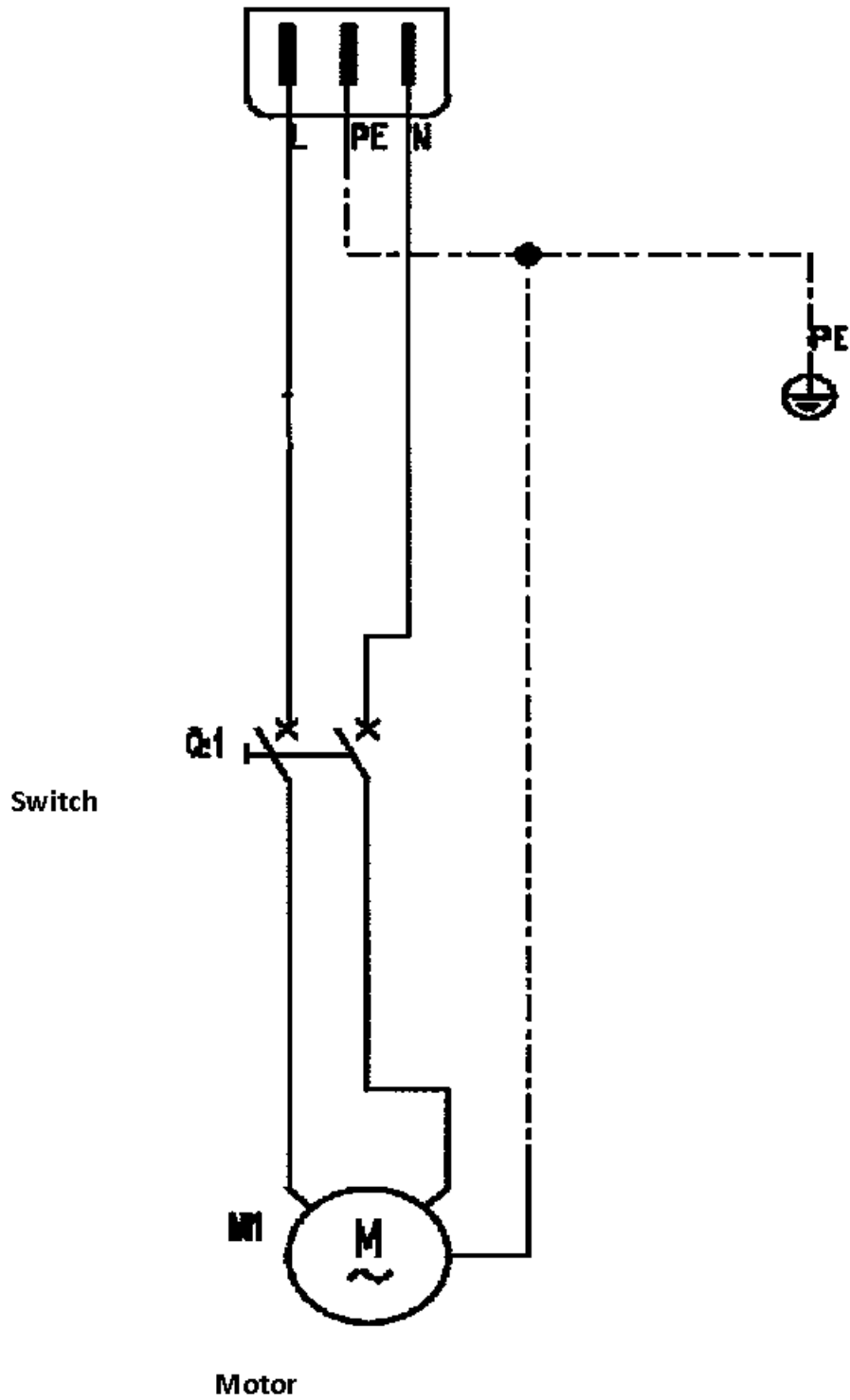



Warranty Registration

Thank you for purchasing an Omcan product. To register your warranty for this product, complete the information below, tear off the card at the perforation and then send to the address specified below. You can also register online by visiting:

Merci d'avoir acheté un produit Omcan. Pour enregistrer votre garantie pour ce produit, complétez les informations ci-dessous, détachez la carte au niveau de la perforation, puis l'envoyer à l'adresse spécifiée ci-dessous. Vous pouvez également vous inscrire en ligne en visitant:

Gracias por comprar un producto Omcan usted. Para registrar su garantía para este producto, complete la información a continuación, cortar la tarjeta en la perforación y luego enviarlo a la dirección indicada a continuación. También puede registrarse en línea en:

www.omcan.com/warrantyregistration.html

For mailing in Canada

Pour postale au Canada

Por correo en Canadá

OMCAN

PRODUCT WARRANTY REGISTRATION

3115 Pepper Mill Court,

Mississauga, Ontario

Canada, L5L 4X5

For mailing in the US

Pour diffusion aux États-Unis

Por correo en los EE.UU.

OMCAN

PRODUCT WARRANTY REGISTRATION

4450 Witmer Industrial Estates, Unit 4,

Niagara Falls, New York

USA, 14305

or Email to: service@omcan.com



Purchaser's Information

Name: _____

Company Name: _____

Address: _____

Telephone: _____

City: _____ Province or State: _____ Postal or Zip: _____

Email Address: _____

Country: _____

Type of Company:

Restaurant Bakery Deli

Butcher Supermarket Caterer

Dealer from which Purchased: _____

Institution (*specify*): _____

Dealer City: _____ Dealer Province or State: _____

Other (*specify*): _____

Invoice: _____

Model Name: _____ Model Number: _____

Serial Number: _____

Machine Description: _____

Date of Purchase (MM/DD/YYYY): _____

Date of Installation (MM/DD/YYYY): _____

Would you like to extend the warranty? Yes No

Thank you for choosing Omcan | Merci d'avoir choisi Omcan | Gracias por elegir Omcan



Since 1951 Omcan has grown to become a leading distributor of equipment and supplies to the North American food service industry. Our success over these many years can be attributed to our commitment to strengthen and develop new and existing relationships with our valued customers and manufacturers. Today with partners in North America, Europe, Asia and South America, we continually work to improve and grow the company. We strive to offer customers exceptional value through our qualified local sales and service representatives who provide convenient access to over 3,500 globally sourced products.

Depuis 1951 Omcan a grandi pour devenir un des “leaders” de la distribution des équipements et matériel pour l’industrie des services alimentaires en Amérique du Nord. Notre succès au cours de ces nombreuses années peut être attribué à notre engagement à renforcer et à développer de nouvelles et existantes relations avec nos clients et les fabricants de valeur. Aujourd’hui avec des partenaires en Amérique du Nord, Europe, Asie et Amérique du Sud, nous travaillons continuellement à améliorer et développer l’entreprise. Nous nous efforçons d’offrir à nos clients une valeur exceptionnelle grâce à nos ventes locales qualifiées et des représentants de service qui offrent un accès facile à plus de 3500 produits provenant du monde entier.

Desde 1951 Omcan ha crecido hasta convertirse en un líder en la distribución de equipos y suministros de alimentos en América del Norte industria de servicios. Nuestro éxito en estos años se puede atribuir a nuestro compromiso de fortalecer y desarrollar nuevas relaciones existentes con nuestros valiosos clientes y fabricantes. Hoy con socios de América del Norte, Europa, Asia y América del Sur, que trabajan continuamente para mejorar y crecer la empresa. Nos esforzamos por ofrecer a nuestros clientes valor excepcional a través de nuestro local de ventas y representantes de los servicios que proporcionan un fácil acceso a más de 3,500 productos con origen a nivel mundial.

