



Tomato Squeezers
Models TS-IT-0150, 0080
Items 41418, 41420
Instruction Manual



STOP
DO NOT RETURN
THIS PRODUCT TO THE STORE

For questions or assistance with this product call OMCAN Toll Free: 1 800 465 0234 Customer Service or visit the Support section of www.omcan.com

Revised - 03/11/2020

CSA
Approved

Toll Free: 1-800-465-0234
Fax: 905-607-0234
Email: service@omcan.com
www.omcan.com

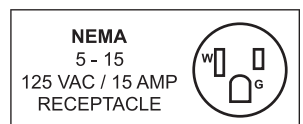

Table of Contents

Model TS-IT-0150 / Model TS-IT-0080

| Section | Page |
|--------------------------------|-------------|
| General Information ----- | 3 - 4 |
| Safety and Warranty ----- | 4 - 5 |
| Technical Specifications ----- | 6 |
| Operation ----- | 6 |
| Maintenance ----- | 6 - 7 |
| Parts Breakdown ----- | 8 - 10 |
| Electrical Schematics ----- | 11 |
| Notes ----- | 12 - 14 |
| Warranty Registration ----- | 15 |



General Information

Omcan Manufacturing and Distributing Company Inc., Food Machinery of America, Inc. dba Omcan and Omcan Inc. are not responsible for any harm or injury caused due to any person's improper or negligent use of this equipment. The product shall only be operated by someone over the age of 18, of sound mind, and not under the influence of any drugs or alcohol, who has been trained in the correct operation of this machine, and is wearing authorized, proper safety clothing. Any modification to the machine voids any warranty, and may cause harm to individuals using the machine or in the vicinity of the machine while in operation.

CHECK PACKAGE UPON ARRIVAL

Upon receipt of an Omcan shipment please inspect for external damage. If no damage is evident on the external packaging, open carton to ensure all ordered items are within the box, and there is no concealed damage to the machine. If the package has suffered rough handling, bumps or damage (visible or concealed), please note it on the bill of lading before accepting the delivery and contact Omcan within 24 hours, so we may initiate a claim with the carrier. A detailed report on the extent of the damage caused to the machine must be filled out within three days, from the delivery date shown in the shipping documents. Omcan has no recourse for damaged products that were shipped collect or third party.

Before operating any equipment, always read and familiarize yourself with all operation and safety instructions.

Omcan would like to thank you for purchasing this machine. It's of the utmost importance to save these instructions for future reference. Also save the original box and packaging for shipping the equipment if servicing or returning of the machine is required.

Omcan Fabrication et distribution Compañie Limité et Food Machinery d'Amérique, dba Omcan et Omcan Inc. ne sont pas responsables de tout dommage ou blessure causé du fait que toute personne ait utilisé cet équipement de façon irrégulière. Le produit ne doit être exploité que par quelqu'un de plus de 18 ans, saine d'esprit, et pas sous l'influence d'une drogue ou d'alcool, qui a été formé pour utiliser cette machine correctement, et est vêtu de vêtements de sécurité approprié. Toute modification de la machine annule toute garantie, et peut causer un préjudice à des personnes utilisant la machine ou des personnes à proximité de la machine pendant son fonctionnement.

VÉRIFIEZ LE COLIS DÈS RÉCEPTION

Dès réception d'une expédition d'Omcan veuillez inspecter pour dommages externes. Si aucun dommage n'est visible sur l'emballage externe, ouvrez le carton afin de s'assurer que tous les éléments commandés sont dans la boîte, et il n'y a aucun dommage dissimulé à la machine. Si le colis n'a subi aucune mauvaises manipulations, de bosses ou de dommages (visible ou cachée), notez-le sur le bond de livraison avant d'accepter la livraison et contactez Omcan dans les 24 heures qui suivent, pour que nous puissions engager une réclamation auprès du transporteur. Un rapport détaillé sur l'étendue des dommages causés à la machine doit être rempli dans un délai de trois jours, à compter de la date de livraison indiquée dans les documents d'expédition. Omcan n'a aucun droit de recours pour les produits endommagés qui ont été expédiés ou cueilli par un tiers transporteur.

General Information

Avant d'utiliser n'importe quel équipement, toujours lire et vous familiariser avec toutes les opérations et les consignes de sécurité.

Omcan voudrais vous remercier d'avoir choisi cette machine. Il est primordial de conserver ces instructions pour une référence ultérieure. Également conservez la boîte originale et l'emballage pour l'expédition de l'équipement si l'entretien ou le retour de la machine est nécessaire.

Omcan Empresa De Fabricacion Y Distribucion Inc. Y Maquinaria De Alimentos De America, Inc. dba Omcan y Omcan Inc. no son responsables de ningun daño o perjuicio causado por cualquier persona inadecuada o el uso descuidado de este equipo. El producto solo podra ser operado por una persona mayor de 18 años, en su sano juicio y no bajo alguna influencia de droga o alcohol, y que este ha sido entrenado en el correcto funcionamiento de esta máquina, y ésta usando ropa apropiada y autorizada. Cualquier modificación a la máquina anula la garantía y puede causar daños a las personas usando la máquina mientras esta en el funcionamiento.

REVISE EL PAQUETE A SU LLEGADA

Tras la recepcion de un envio Omcan favor inspeccionar daños externos. Si no hay daños evidentes en el empaque exterior, Habra el carton para asegurarse que todos los articulos solicitados estén dentro de la caja y no encuentre daños ocultos en la máquina. Si el paquete ha sufrido un manejo de poco cuidado, golpes o daños (visible o oculto) por favor anote en la factura antes de aceptar la entrega y contacte Omcan dentro de las 24 horas, de modo que podamos iniciar una reclamación con la compañía. Un informe detallado sobre los daños causados a la máquina debe ser llenado en el plazo de tres días, desde la fecha de entrega que se muestra en los documentos de envío. Omcan no tiene ningun recurso por productos dañados que se enviaron a recoger por terceros.

Antes de utilizar cualquier equipo, siempre lea y familiarizarse con todas las instrucciones de funcionamiento y seguridad.

Omcan le gustaría darle las gracias por la compra de esta máquina. Es de la mayor importancia para salvar estas instrucciones para futuras consultas. Además, guarda la caja original y el embalaje para el envío del equipo si servicio técnico o devolución de la máquina que se requiere.

Safety and Warranty

IMPORTANT SAFEGUARDS

When using electrical appliances, basic safety precautions should always be followed including the following:

- 1. Read all instructions.**
- 2. To protect against risks of electrical shock do not put in water or other liquid.**
- 3. Close supervision is necessary when any appliance is used by or near children.**

Safety and Warranty

4. Unplug from outlet when not in use and before putting on or taking off parts and before cleaning.
5. Avoid contacting moving parts.
6. Do not operate any appliance with a damaged cord or plug or after the appliance malfunction, or if it is dropped or damaged in any manner. Call Omcan to arrange the examination, repair or electrical or mechanical adjustment.
7. The use of attachments not recommended or sold by Omcan may cause fire, electric shock or injury.
8. Do not use outdoors.
9. Do not let cord hang over edge of table or counter.
10. Never feed food or dough by hand. Always use food pusher.
11. Blades are sharp. Handle carefully.
12. Do not use fingers to scrape food away from discharge disc while appliance is operating. Cut type injury may result.
13. This appliance is not intended for use by persons (including children) with reduced physical, sensory or mental capabilities, or lack of experience and knowledge, unless they have been given supervision or instruction concerning use of the appliance by a person responsible for their safety.
14. Acoustic level less than 60 dBA.

1 YEAR PARTS AND LABOUR BENCH WARRANTY

Within the warranty period, contact Omcan Inc. at 1-800-465-0234 to schedule a drop off to either an Omcan authorized service depot in the area, or to an Omcan Service warehouse to repair the equipment.

Unauthorized maintenance will void the warranty. Warranty covers electrical and part failures, not improper use.

Please see <https://omcan.com/disclaimer> for complete info.

WARNING:

The packaging components are classified as normal solid urban waste and can therefore be disposed of without difficulty.

In any case, for suitable recycling, we suggest disposing of the products separately (differentiated waste) according to the current norms.

DO NOT DISCARD ANY PACKAGING MATERIALS IN THE ENVIRONMENT!

Technical Specifications

| Model | TS-IT-0150 | TS-IT-0080 |
|----------------------|--|--|
| Power | 0.4 HP / 0.3 kW | 0.57 HP / 0.43 kW |
| Worm RPM | 192 | 96 |
| Electrical | 120V / 60Hz / 1Ph | 120V / 60Hz / 1Ph |
| Weight | 23.1 lbs. / 10.5 kgs. | 36.3 lbs. / 16 kgs. |
| Packaging Weight | 24 lbs. / 10.9 kgs. | 38.5 lbs. / 17.5 kgs. |
| Dimensions | 22.5" x 12" x 15.1" 572 x 305 x 384mm | 26" x 10.5" x 20" 660 x 267 x 508mm |
| Packaging Dimensions | 19.3" x 11.3" x 12.3" 489 x 286 x 311mm | 23" x 16.8" x 14.3" 584 x 425 x 362mm |
| Item Number | 41418 | 41420 |

Operation

TOMATO SQUEEZER UNIT

Tomato squeezer propeller made in acetal resin suitable for food contact, body in cast iron tested for foodstuffs and treated with epoxy paint for foodstuffs. Nylon tow pin inserted on tin-plated steel. Filter cone, funnel and drip pan are entirely made of 18/10 stainless steel.

For space requirements, the machine is partially disassembled in the packing; it is necessary to insert the tow pin with the spring into the hole in the cast iron body. Insert the propeller into the cast iron body fitting it onto the square of the tow pin. Then put the filter cone onto the propeller pressing and turning it counterclockwise to fit the tabs of the ring nut into the niches in the cast iron body. Screw the funnel onto the threaded neck of the cast iron body and hook the drip pan onto the filter cone and onto the cast iron casing by means of the clips. The machine is then ready for use: the machine must definitely not be run dry (with no tomato).

If the propeller jams, before taking any further action on the machine put the switch onto the "OFF" position and unplug from the electrical socket. When the work is finished, unscrew the funnel, unhook the drip pan, turn the filter cone clockwise to remove the propeller and the tow pin with the spring. Remove the cast iron casing from the reduction gear cover, then wash, carefully dry and eventually grease all the parts that have come into contact with the food. Before replacing the appliance it is advisable to put the red cap back on in the place of the cap with bleed.

Maintenance

- Before carrying out assembly, disassembly, die plate replacement and cleaning operations, switch off the

Maintenance

motor and unplug the unit from the electrical socket, to avoid risks of electric shock.

- After every use disassemble, wash and dry all press parts carefully.
- In case of blockage of the press, disconnect the plug cable from the socket immediately to avoid risks of damage the machine.
- Close supervision is required when this product is used near children.

REFERENCE

| Item Number | Model Number | Description | Manufacturer Model Number |
|-------------|--------------|--|---------------------------|
| 41418 | TS-IT-0150 | Tomato Squeezer 192 RPM 300W 120V/60/1 cCSAus | 17410J/ICSA |
| 41420 | TS-IT-0080 | Tomato Squeezer 96 RPM 0.58 HP / 430 W 110V/60/1 cCSAus | 07600/CSA |

Parts Breakdown

Model TS-IT-0150 41418

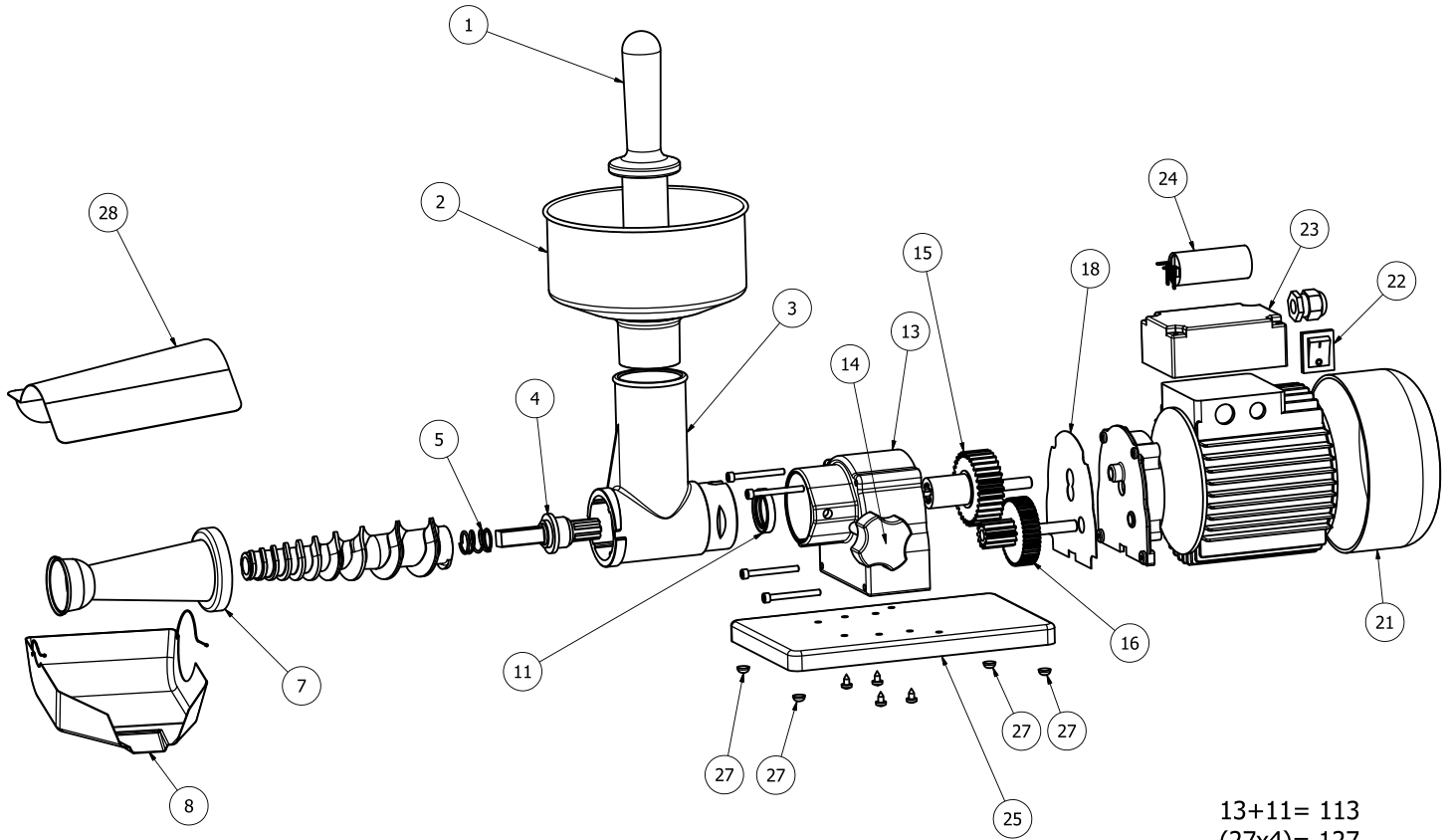

13+11= 113
 (27x4)= 127
 25+(27x4)= 125

Parts Breakdown

Model TS-IT-0080 41420

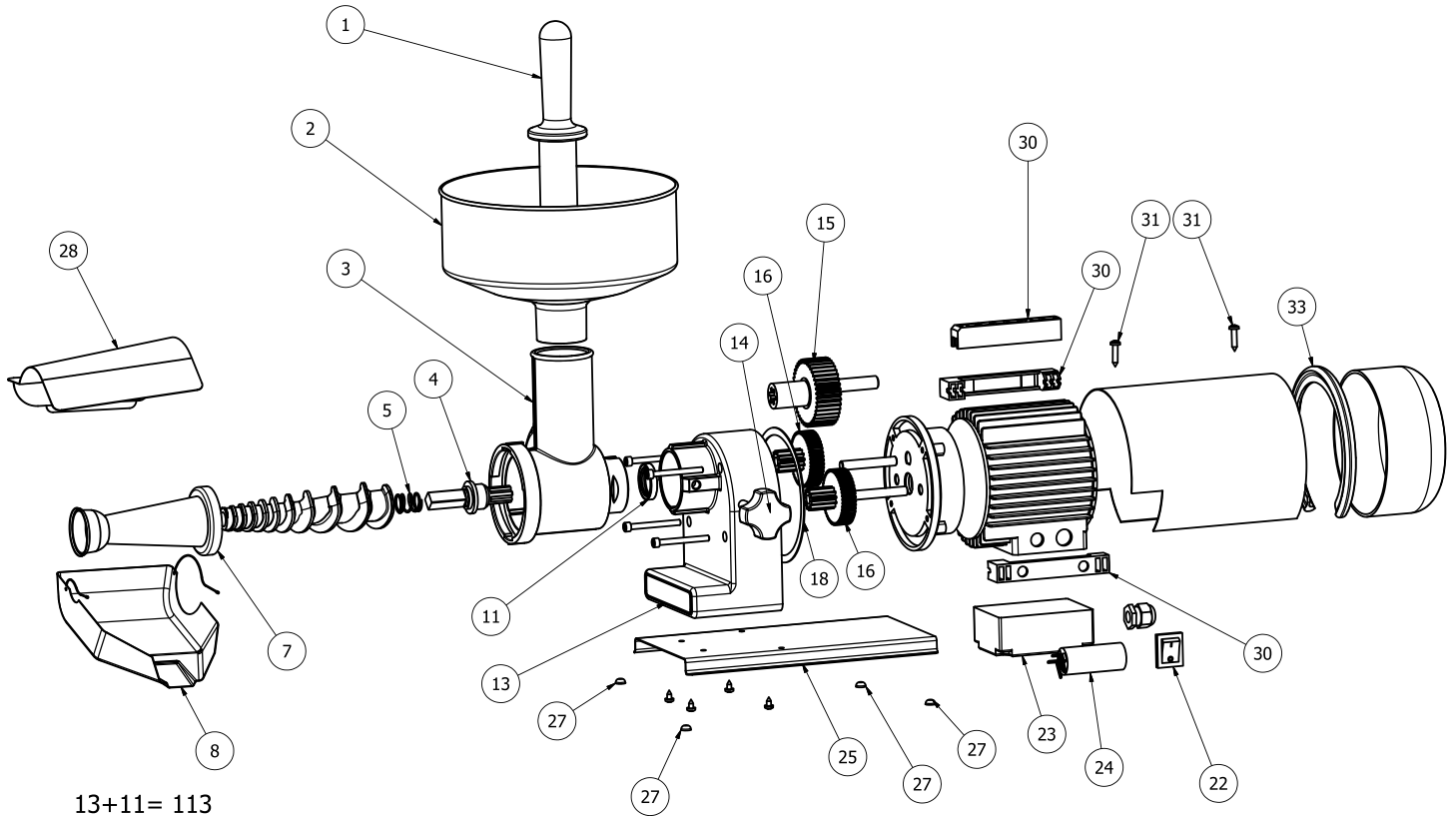

$13+11= 113$
 $30+31+33= 130$
 $(27 \times 4)= 127$
 $25+(27 \times 4)= 125$

Parts Breakdown

Model TS-IT-0150 41418

| Item No. | Description | Position | Item No. | Description | Position | Item No. | Description | Position |
|----------|--|----------|----------|--|----------|----------|---|----------|
| 15241 | Plunger for 17410J/ICSA | 1 | 15246 | Knob for 17410J/ICSA | 14 | 67463 | Capacitor for 17410J/ICSA | 24 |
| 19162 | Inox Hopper for 17410J/ICSA | 2 | 27655 | Big Gear for 17410J/ICSA | 15 | AD001 | Splashes Protector for 17410J/ICSA | 28 |
| 61934 | Body for 17410J/ICSA | 3 | 45893 | Small Gear 12 Teeth / 60 Teeth for 17410J/ICSA | 16 | AD000 | Reduction Unit Case with Sealing Ring for 17410J/ICSA | 113 |
| 61933 | Joint for 17410J/ICSA | 4 | 27662 | Motor Reducer Gasket for 17410J/ICSA | 18 | 67465 | Base and 4 Feet Set for 17410J/ICSA | 125 |
| 61932 | Worm Spring for 17410J/ICSA | 5 | 64286 | Motor Fan Cover for 17410J/ICSA | 21 | 67464 | 4 Feet Set for 17410J/ICSA | 127 |
| 19236 | Stainless Filter for 17410J/ICSA | 7 | 67462 | Switch for 17410J/ICSA | 22 | 64285 | Motor Fan for 17410J/ICSA | |
| AC999 | Stainless Steel Collector with Hooks for 17410J/ICSA | 8 | 45128 | Switch Box for 17410J/ICSA | 23 | 61430 | Motor Reductor for 17410J/ICSA | |

Model TS-IT-0080 41420

| Item No. | Description | Position | Item No. | Description | Position | Item No. | Description | Position |
|----------|--|----------|----------|------------------------------------|----------|----------|---|----------|
| 15241 | Plunger for 07600/CSA | 1 | 19151 | Large Gear for 07600/CSA | 15 | 15255 | Housing for 07600/CSA | 113 |
| 19162 | Inox Hopper for 07600/CSA | 2 | 66043 | Small Gear for 07600/CSA | 16 | 67473 | Base and 4 Feet Set for 07600/CSA | 125 |
| AD002 | Body for 07600/CSA | 3 | 27663 | Motor Reducer Gasket for 07600/CSA | 18 | 67472 | 4 Feet Set for 07600/CSA | 127 |
| 15260 | Joint for 07600/CSA | 4 | 15247 | Motor Cover for 07600/CSA | 21 | 67479 | Spacers Kit and Screws Kit and Gasket for 07600/CSA | 130 |
| 15256 | Worm Spring for 07600/CSA | 5 | 31249 | Switch for 07600/CSA | 22 | 40300 | Cooling Fan for 07600/CSA | |
| 15348 | Stainless Steel Filter Screen for 07600/CSA | 7 | 45128 | Switch Box for 07600/CSA | 23 | 23499 | Adapter for 07600/CSA | |
| AD003 | Stainless Steel Collector with Hooks for 07600/CSA | 8 | 67477 | Capacitor for 07600/CSA | 24 | 67480 | Motoreduction Unit for 07600/CSA | |
| 15246 | Knob for 07600/CSA | 14 | 31322 | Splashes Protection for 07600/CSA | 28 | | | |

Electrical Schematics

Model TS-IT-0150 41418

Model TS-IT-0080 41420

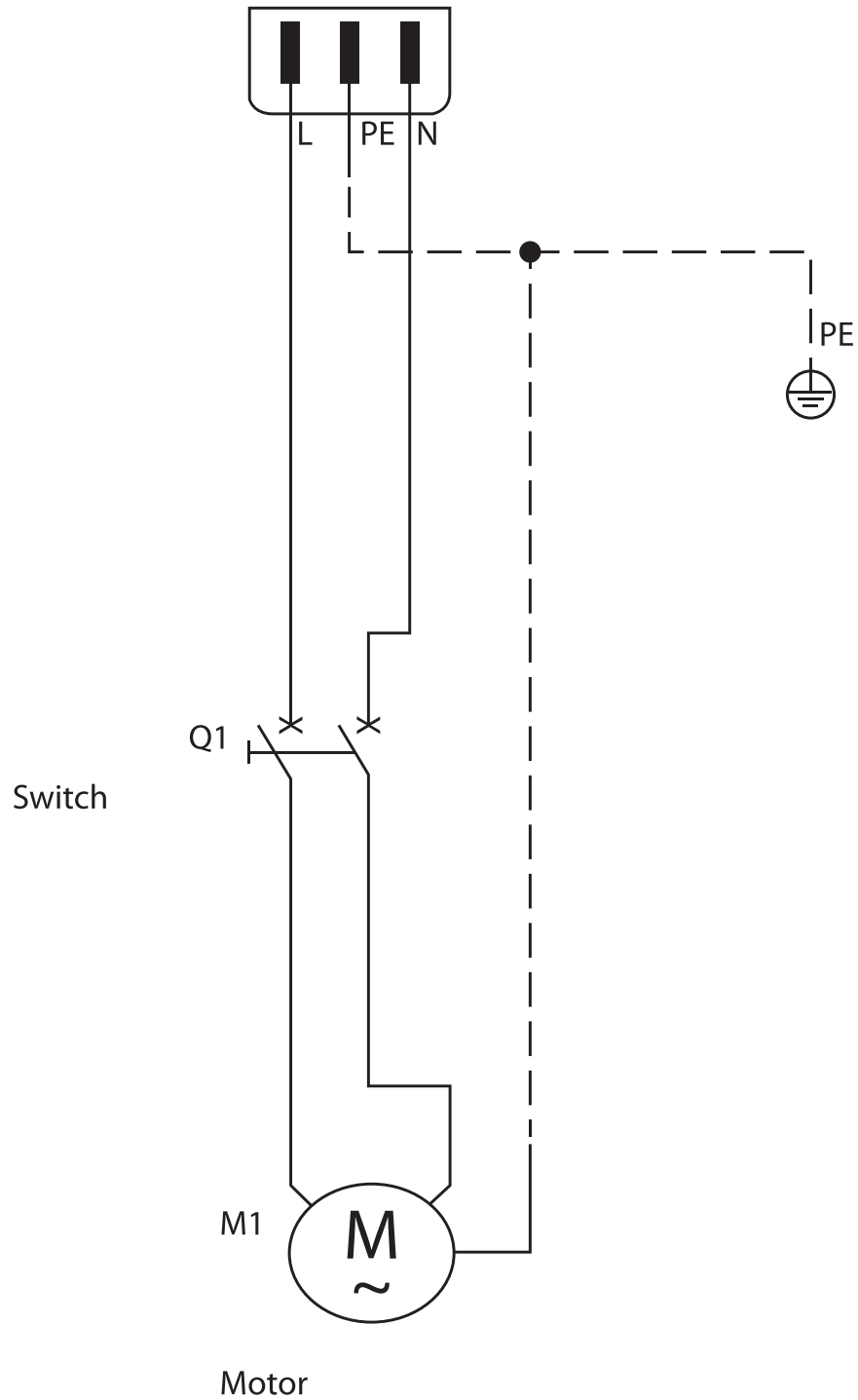



Warranty Registration

Thank you for purchasing an Omcan product. To register your warranty for this product, complete the information below, tear off the card at the perforation and then send to the address specified below. You can also register online by visiting:

Merci d'avoir acheté un produit Omcan. Pour enregistrer votre garantie pour ce produit, complétez les informations ci-dessous, détachez la carte au niveau de la perforation, puis l'envoyer à l'adresse spécifiée ci-dessous. Vous pouvez également vous inscrire en ligne en visitant:

Gracias por comprar un producto Omcan usted. Para registrar su garantía para este producto, complete la información a continuación, cortar la tarjeta en la perforación y luego enviarlo a la dirección indicada a continuación. También puede registrarse en línea en:

<https://omcan.com/warranty-registration/>

For mailing in Canada

Pour postale au Canada

Por correo en Canadá

OMCAN

PRODUCT WARRANTY REGISTRATION

3115 Pepper Mill Court,

Mississauga, Ontario

Canada, L5L 4X5

For mailing in the US

Pour diffusion aux États-Unis

Por correo en los EE.UU.

OMCAN

PRODUCT WARRANTY REGISTRATION

4450 Witmer Industrial Estates, Unit 4,

Niagara Falls, New York

USA, 14305

or email to: service@omcan.com



Purchaser's Information

Name: _____

Address: _____

City: _____ Province or State: _____ Postal or Zip: _____

Country: _____

Dealer from which Purchased: _____

Dealer City: _____ Dealer Province or State: _____

Invoice: _____

Model Name: _____ Model Number: _____

Machine Description: _____

Date of Purchase (MM/DD/YYYY): _____

Would you like to extend the warranty? Yes No

Company Name: _____

Telephone: _____

Email Address: _____

Type of Company:

Restaurant Bakery Deli

Butcher Supermarket Caterer

Institution (specify): _____

Other (specify): _____

Serial Number: _____

Date of Installation (MM/DD/YYYY): _____

Thank you for choosing Omcan | Merci d'avoir choisi Omcan | Gracias por elegir Omcan



Since 1951 Omcan has grown to become a leading distributor of equipment and supplies to the North American food service industry. Our success over these many years can be attributed to our commitment to strengthen and develop new and existing relationships with our valued customers and manufacturers. Today with partners in North America, Europe, Asia and South America, we continually work to improve and grow the company. We strive to offer customers exceptional value through our qualified local sales and service representatives who provide convenient access to over 5,000 globally sourced products.

Depuis 1951 Omcan a grandi pour devenir un des “leaders” de la distribution des équipements et matériel pour l’industrie des services alimentaires en Amérique du Nord. Notre succès au cours de ces nombreuses années peut être attribué à notre engagement à renforcer et à développer de nouvelles et existantes relations avec nos clients et les fabricants de valeur. Aujourd’hui avec des partenaires en Amérique du Nord, Europe, Asie et Amérique du Sud, nous travaillons continuellement à améliorer et développer l’entreprise. Nous nous efforçons d’offrir à nos clients une valeur exceptionnelle grâce à nos ventes locales qualifiées et des représentants de service qui offrent un accès facile à plus de 5000 produits provenant du monde entier.

Desde 1951 Omcan ha crecido hasta convertirse en un líder en la distribución de equipos y suministros de alimentos en América del Norte industria de servicios. Nuestro éxito en estos años se puede atribuir a nuestro compromiso de fortalecer y desarrollar nuevas relaciones existentes con nuestros valiosos clientes y fabricantes. Hoy con socios de América del Norte, Europa, Asia y América del Sur, que trabajan continuamente para mejorar y crecer la empresa. Nos esforzamos por ofrecer a nuestros clientes valor excepcional a través de nuestro local de ventas y representantes de los servicios que proporcionan un fácil acceso a más de 5,000 productos con origen a nivel mundial.

