



Refrigerated Showcase
Model RS-CN-0500
Item 34874
Instruction Manual



Revised - 12/03/2019



Toll Free: 1-800-465-0234
Fax: 905-607-0234
Email: service@omcan.com
www.omcan.com

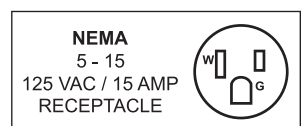

Table of Contents

Model RS-CN-0500

| Section | Page |
|--------------------------------|-------------|
| General Information ----- | 3 - 4 |
| Safety and Warranty ----- | 4 - 6 |
| Technical Specifications ----- | 6 |
| Operation ----- | 6 - 7 |
| Maintenance ----- | 8 |
| Troubleshooting ----- | 8 - 9 |
| Parts Breakdown ----- | 10 - 11 |
| Electrical Schematics ----- | 12 |
| Notes ----- | 13 - 14 |
| Warranty Registration ----- | 15 |



General Information

Omcan Manufacturing and Distributing Company Inc., Food Machinery of America, Inc. dba Omcan and Omcan Inc. are not responsible for any harm or injury caused due to any person's improper or negligent use of this equipment. The product shall only be operated by someone over the age of 18, of sound mind, and not under the influence of any drugs or alcohol, who has been trained in the correct operation of this machine, and is wearing authorized, proper safety clothing. Any modification to the machine voids any warranty, and may cause harm to individuals using the machine or in the vicinity of the machine while in operation.

CHECK PACKAGE UPON ARRIVAL

Upon receipt of an Omcan shipment please inspect for external damage. If no damage is evident on the external packaging, open carton to ensure all ordered items are within the box, and there is no concealed damage to the machine. If the package has suffered rough handling, bumps or damage (visible or concealed), please note it on the bill of lading before accepting the delivery and contact Omcan within 24 hours, so we may initiate a claim with the carrier. A detailed report on the extent of the damage caused to the machine must be filled out within three days, from the delivery date shown in the shipping documents. Omcan has no recourse for damaged products that were shipped collect or third party.

Before operating any equipment, always read and familiarize yourself with all operation and safety instructions.

Omcan would like to thank you for purchasing this machine. It's of the utmost importance to save these instructions for future reference. Also save the original box and packaging for shipping the equipment if servicing or returning of the machine is required.

Omcan Fabrication et distribution Compagnie Limitée et Food Machinery d'Amérique, dba Omcan et Omcan Inc. ne sont pas responsables de tout dommage ou blessure causé du fait que toute personne ait utilisé cet équipement de façon irrégulière. Le produit ne doit être exploité que par quelqu'un de plus de 18 ans, sain d'esprit, et pas sous l'influence d'une drogue ou d'alcool, qui a été formé pour utiliser cette machine correctement, et est vêtu de vêtements de sécurité appropriés. Toute modification de la machine annule toute garantie, et peut causer un préjudice à des personnes utilisant la machine ou des personnes à proximité de la machine pendant son fonctionnement.

VÉRIFIEZ LE COLIS DÈS RÉCEPTION

Dès réception d'une expédition d'Omcan veuillez inspecter pour dommages externes. Si aucun dommage n'est visible sur l'emballage externe, ouvrez le carton afin de s'assurer que tous les éléments commandés sont dans la boîte, et il n'y a aucun dommage dissimulé à la machine. Si le colis n'a subi aucune mauvaises manipulations, de bosses ou de dommages (visible ou cachée), notez-le sur le bond de livraison avant d'accepter la livraison et contactez Omcan dans les 24 heures qui suivent, pour que nous puissions engager une réclamation auprès du transporteur. Un rapport détaillé sur l'étendue des dommages causés à la machine doit être rempli dans un délai de trois jours, à compter de la date de livraison indiquée dans les documents d'expédition. Omcan n'a aucun droit de recours pour les produits endommagés qui ont été expédiés ou cueilli par un tiers transporteur.

General Information

Avant d'utiliser n'importe quel équipement, toujours lire et vous familiariser avec toutes les opérations et les consignes de sécurité.

Omcan voudrais vous remercier d'avoir choisi cette machine. Il est primordial de conserver ces instructions pour une référence ultérieure. Également conservez la boîte originale et l'emballage pour l'expédition de l'équipement si l'entretien ou le retour de la machine est nécessaire.

Omcan Empresa De Fabricacion Y Distribucion Inc. Y Maquinaria De Alimentos De America, Inc. dba Omcan y Omcan Inc. no son responsables de ningun daño o perjuicio causado por cualquier persona inadecuada o el uso descuidado de este equipo. El producto solo podra ser operado por una persona mayor de 18 años, en su sano juicio y no bajo alguna influencia de droga o alcohol, y que este ha sido entrenado en el correcto funcionamiento de esta máquina, y ésta usando ropa apropiada y autorizada. Cualquier modificación a la máquina anula la garantía y puede causar daños a las personas usando la máquina mientras esta en el funcionamiento.

REVISE EL PAQUETE A SU LLEGADA

Tras la recepcion de un envio Omcan favor inspeccionar daños externos. Si no hay daños evidentes en el empaque exterior, Habra el carton para asegurarse que todos los articulos solicitados estén dentro de la caja y no encuentre daños ocultos en la máquina. Si el paquete ha sufrido un manejo de poco cuidado, golpes o daños (visible o oculto) por favor anote en la factura antes de aceptar la entrega y contacte Omcan dentro de las 24 horas, de modo que podamos iniciar una reclamación con la compañía. Un informe detallado sobre los daños causados a la máquina debe ser llenado en el plazo de tres días, desde la fecha de entrega que se muestra en los documentos de envío. Omcan no tiene ningun recurso por productos dañados que se enviaron a recoger por terceros.

Antes de utilizar cualquier equipo, siempre lea y familiarizarse con todas las instrucciones de funcionamiento y seguridad.

Omcan le gustaría darle las gracias por la compra de esta máquina. Es de la mayor importancia para salvar estas instrucciones para futuras consultas. Además, guarda la caja original y el embalaje para el envío del equipo si servicio técnico o devolución de la máquina que se requiere.

Safety and Warranty

HANDLING AND INSTALLATION

| | |
|--|---|
| Handle with care Unplug from the wall socket before moving. Never tilt the refrigerator over 45 degrees during handling. | Storage Always store the refrigerator in a dry place. |
|--|---|



Safety and Warranty

| | |
|---|--|
| <p>Sufficient space To allow for proper air circulation and increased refrigeration capabilities, the refrigerator must have at least 4"/10cm of space between wall/ceiling and the machine.</p> | <p>Proper ventilation Always place the refrigerator in an area with good ventilation. For first time use, set in location and wait at least 2 hours before plugging into wall socket.</p> |
| <p>Away from heat source Never place the refrigerator near any type of heat source or in direct sunlight, as it reduces refrigeration capabilities.</p> | <p>No heavy load Never put heavy items on top of the refrigerator.</p> |
| <p>No altercations/tampering Never tamper with or make changes to the refrigerator. Changes and add-ons should not be installed to the inside or outside of the refrigerator.</p> | <p>Stable location Unpack and place the refrigerator on flat, solid ground.</p> |

PREPARATION AND POWER SUPPLY

| | |
|---|---|
| <p>Exclusive power outlet Power supply should be 110V, single phase AC with exclusive single phase three pin outlet (125V/15A). The power outlet must be in close proximity to the ground.</p> | <p>No shared power outlets Refrigerator cable should never share the power outlet with any other appliance, as cable will overheat and may result in a fire.</p> |
| <p>Protect cables Extra caution should be used when handling cables, as broken or damaged cables can cause sparking and may result in a fire.</p> | <p>No water flushing Never flush the refrigerator surface. This can cause leakage, which may result in electrical damage or fire.</p> |
| <p>Never store flammables and explosives No explosives or flammables should be stored in, or in proximity to, the refrigerator, such as gasoline, alcohol, and adhesives.</p> | <p>No spray Never spray flammables such as paint or coating near the refrigerator. This may cause fire or malfunction.</p> |
| <p>After power outage After a power outage or the unplugging of the refrigerator, wait at least 5 minutes before plugging it back in.</p> | <p>No medicine Medicine should not be stored inside of the refrigerator.</p> |

1 YEAR PARTS AND LABOUR WARRANTY

Within the warranty period, contact Omcan Inc. at 1-800-465-0234 to schedule an Omcan authorized service technician to repair the equipment locally.

Unauthorized maintenance will void the warranty. Warranty covers electrical and part failures not improper use.

Please see <https://omcan.com/disclaimer> for complete info.

Safety and Warranty

WARNING:

The packaging components are classified as normal solid urban waste and can therefore be disposed of without difficulty.

In any case, for suitable recycling, we suggest disposing of the products separately (differentiated waste) according to the current norms.

DO NOT DISCARD ANY PACKAGING MATERIALS IN THE ENVIRONMENT!

Technical Specifications

| | |
|----------------------------------|--|
| Model | RS-CN-0500 |
| Power | 680 W |
| Capacity | 500 L / 17.65 cu. ft. |
| Electrical | 110V / 60Hz / 1Ph |
| Lamp Power | 12 W (LED) |
| Temperature Range | 0°C - 12°C / 32°F - 53.6°F |
| Refrigerant and Injection | R404a (320g) |
| Rated Current | 3.7A |
| Shelf Size | 22.6" x 22" / 575 x 559mm |
| Dimensions | 25.6" x 25.6" x 76.6" / 650 x 650 x 1945mm |
| Weight | 297 lbs. / 134.7 kgs. |
| Item Number | 34874 |

Operation

BEFORE USE

- Plug refrigerator into the 110V exclusive socket.
- After the refrigerator is running, confirm that air suction/filtration is in working order and that it is sufficiently cold. After checking to make sure the refrigerator is working properly, it may be used.

DIGITAL TEMPERATURE CONTROLLER

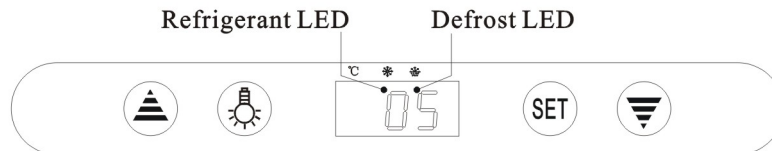

FEATURES OF FUNCTION

- Small, integrated digital controller, which is applicable to the compressor of 1 Hp. Located behind the front grill.
- Main functions are: Temperature Display/Temperature Control/Manual-Automatic /Light Control/Value Storing/Self-Testing/Parameter Locking.

FRONT PANEL OPERATION

1. Set temperature: Press **SET** button; set temperature will be displayed. Press **▲** or **▼** button to modify and store the displayed value. Press **SET** button to exit the adjustment and display the cold-room temperature.
2. If no button is pressed within 10 seconds, the cold-room temperature will be displayed.
3. Lighting: Press **☹** button to activate light in refrigerator; press again to turn off. Manual start/stop defrost: Press **☹** button and hold for 6 seconds to either defrost or to stop defrost.
4. Refrigeration LED: During refrigeration, the LED is on. When the cold room temperature is constant, the LED is off. During delay start, the LED flashes.
5. Defrost LED: During defrosting, the LED is on. When it stops defrosting, the LED is off. During the delay of defrost, the LED flashed.

CAUTION

- Never block the air outlet and suction to keep the air circulation and refrigeration capability constant.
- Do not overfill refrigerator with food, as it will influence the cooling effect. If needed, adjust the rack height for proper food storage.
- Cool down hot food to room temperature before placing inside the refrigerator.
- When power supply has been cut off, reduce opening times and maintain cool temperature in refrigerator.
- To avoid scalding, never touch the compressor.
- If the supply cord is damaged, it must be replaced by the manufacturer, its service agent, or similarly qualified persons in order to avoid hazard.
- This appliance is not intended for use by persons (including children) with reduced physical, sensory or mental capabilities, or lack of experience and knowledge, unless they have been given supervision or instruction concerning use of the appliance by a person responsible for their safety.
- Children should be supervised to ensure that they do not play with the appliance.

Maintenance

1. Cabinet Cleaning:
 - a. The product should be maintained and cleaned periodically with power supply disconnected. In cleaning, please use mild-rinsing water or non-corrosive products. Do not wash directly with water faucet.
 - b. Clean outside of unit using a soft cloth with neutral detergent, and dry with a separate soft cloth.
 - c. Clean inside racks by removing them from the unit and clean with water.
2. When shutting down unit for a long period of time, take out all food and unplug wall socket. Clean inside and outside thoroughly, and keep door open to sufficiently dry.
3. As glass breaks easily, keep far away from children.
4. Frequently observe the operation of the product. In case of any abnormal noise or smell, cut off the power supply immediately and call professionals. Do not restart the product before source of trouble is found.
5. We will not be responsible for any accidents acquired through failure to follow previous notices.

Troubleshooting

| Trouble | Causes | Solutions |
|--|---|--|
| Strange noise under the bottom shelf. | Fan blade broken. | Power off and fix the blade. |
| Non-refrigerating in spite of normal operation. | Unit off. | Power on. |
| | Melting process. | Stop melting. |
| | Refrigerant leaking. | Patch the leak and refill refrigerant. |
| | Unit failure. | Call Omcan. |
| Weak air from air curtain, and higher cabinet temperature. | Evaporator blocked by frost. | Increase melting frequency. |
| | Inside fan damaged. | Replace the fan. |
| | Too low point of temperature controller. | Adjust the set point. |
| | Vent blocked by storage. | Remove the storage. |
| Normal air curtain, but higher cabinet temperature. | Insufficient refrigerant. | Refill the refrigerant. |
| | Too high set point of temperature controllers. | Adjust the set point for the temperature controller. |
| | The wind curtain disturbed by strong air flow. | Removing the disturbing factors. |
| | Ambient temperature or humidity beyond standards. | Improve the conditions. |
| Melting water overflows. | Heating pipe for melting water damaged. | Replace the heating pipe. |
| | Water level controller failure. | Replace the water level controller. |
| | Ambient temperature or humidity beyond standards. | Improve the conditions. |

Troubleshooting

| | | |
|--|--|-------------------------------------|
| Normal air curtain, but periodical fluctuation of cabinet temperature. | Condenser contaminated. | Clean the condenser. |
| | Poor venting of the unit. | Improve the venting conditions. |
| | Heat protection of compressor failure. | Replace the heat protection. |
| | Capillary is blocked by ice. | Replace the drying filter. |
| | Temperature controller failure. | Replace the temperature controller. |

NOTE

Following occurrences are not problems:

- The murmur of water is heard when the refrigerator is working. It is a normal occurrence as the coolant is circulating in the system.
- When the weather is damp, condensation might be found on the outside of the refrigerator. It is caused by high humidity. Simply use cloth to wipe it off.

REFERENCE

| Item Number | Model Number | Description | Manufacturer Model Number |
|-------------|--------------|--|---------------------------|
| 34874 | RS-CN-0500 | Refrigerated Showcase 500 L / 17.7 cu. ft. 110V/60/1 cQPSus | RT500L |

Parts Breakdown

Model RS-CN-0500 34874

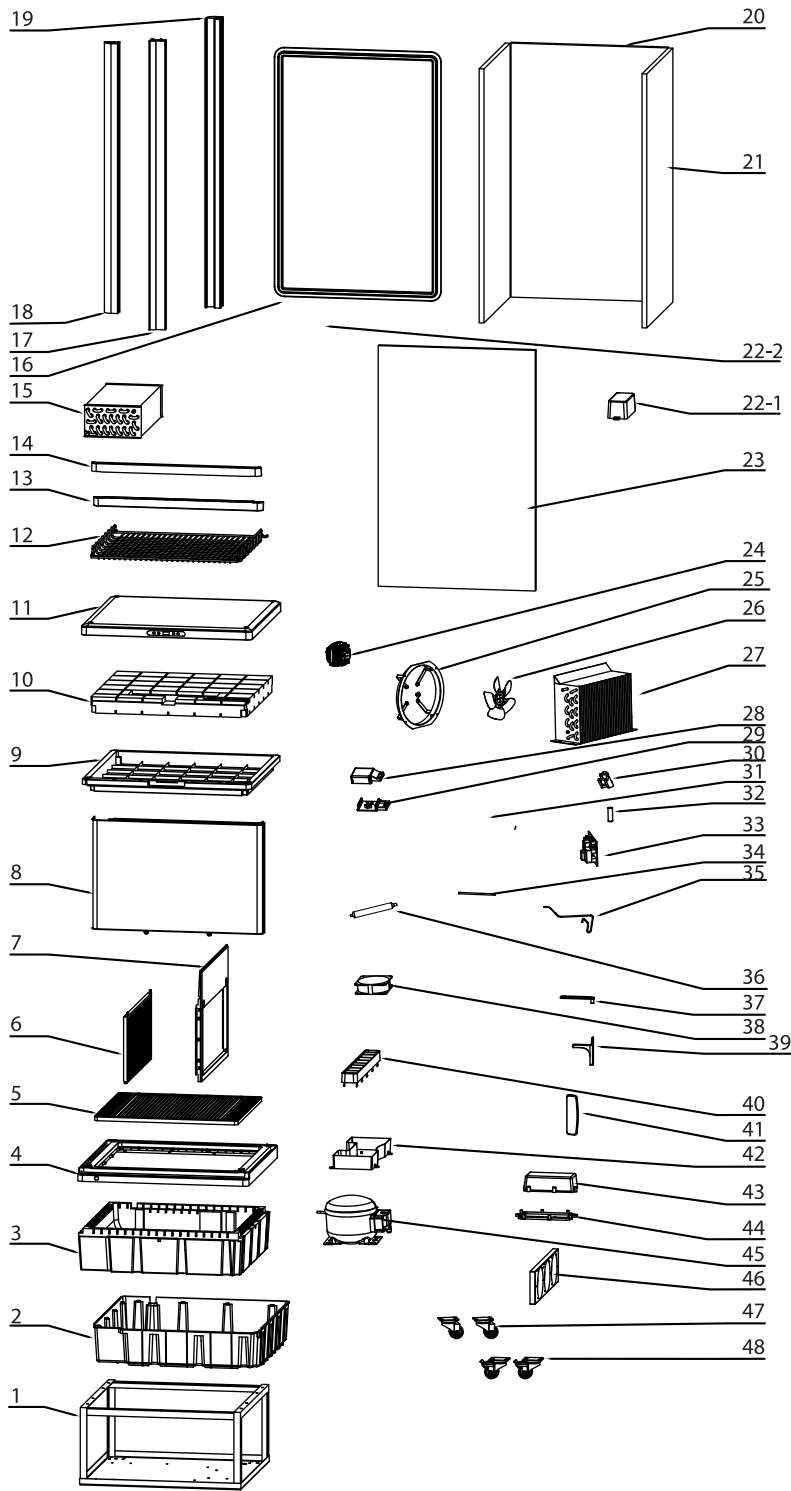

Parts Breakdown

Model RS-CN-0500 34874

| Item No. | Description | Position | Item No. | Description | Position | Item No. | Description | Position |
|----------|---------------------------------------|----------|----------|--------------------------------------|----------|----------|--------------------------------|----------|
| 60908 | Base for RT500L | 1 | 60925 | Left and Right Door Frame for RT500L | 18 | 60143 | Filling Pipe for RT500L | 34 |
| 60909 | Plastic Base of Evaporator for RT500L | 2 | 60926 | Rear Pole for RT500L | 19 | 60941 | Evaporator Pipe for RT500L | 35 |
| 60910 | Foam Base for Evaporator for RT500L | 3 | 60927 | Rear Glass for RT500L | 20 | 79319 | Dry Filter for RT500L | 36 |
| 60911 | Inner Ventilated Tray for RT500L | 4 | 60928 | Side Glass for RT500L | 21 | 30587 | Upper Gemel for RT500L | 37 |
| 60912 | Outer Ventilated Tray for RT500L | 5 | 60595 | LED Transformer for RT500L | 22-1 | 60944 | Motor of Evaporator for RT500L | 38 |
| 60913 | Inner Enclosure Frame for RT500L | 6 | 60929 | LED Light for RT500L | 22-2 | 60945 | Stiffener for RT500L | 39 |
| 60914 | Outer Enclosure Frame for RT500L | 7 | 60930 | Door Glass for RT500L | 23 | 60946 | Air Outlet Cover for RT500L | 40 |
| 60915 | Rear Grill for RT500L | 8 | 60931 | Motor of Condenser for RT500L | 24 | 60947 | Door Handle for RT500L | 41 |
| 60916 | Light Ceiling for RT500L | 9 | 60932 | Flange for RT500L | 25 | 60948 | Water Receiver for RT500L | 42 |
| 60917 | Foam of Light Ceiling for RT500L | 10 | 60933 | Fan Blade of Condenser for RT500L | 26 | 60137 | Controller Box for RT500L | 43 |
| 60918 | Outer Plastic Panel for RT500L | 11 | 60934 | Condenser for RT500L | 27 | 60136 | Controller Panel for RT500L | 44 |
| AC195 | Shelf for RT500L | 12 | 79359 | Cover of Junction Box for RT500L | 28 | 60949 | Compressor for RT500L | 45 |
| 60920 | Bottom Door Frame for RT500L | 13 | 61244 | Junction Box for RT500L | 29 | 60950 | Motor Bracket for RT500L | 46 |
| 60921 | Upper Door Frame for RT500L | 14 | 45107 | Shelf Clips for RT500L | 30 | 60561 | Rear Wheels for RT500L | 47 |
| 60922 | Evaporator for RT500L | 15 | 79290 | Power Cord for RT500L | 31 | 60562 | Front Wheels for RT500L | 48 |
| 60923 | Door Gasket for RT500L | 16 | 30606 | Door Pin for RT500L | 32 | | | |
| 60924 | Front Poles of Shelves for RT500L | 17 | 60939 | Digital Controller for RT500L | 33 | | | |

Electrical Schematics

Model RS-CN-0500 34874

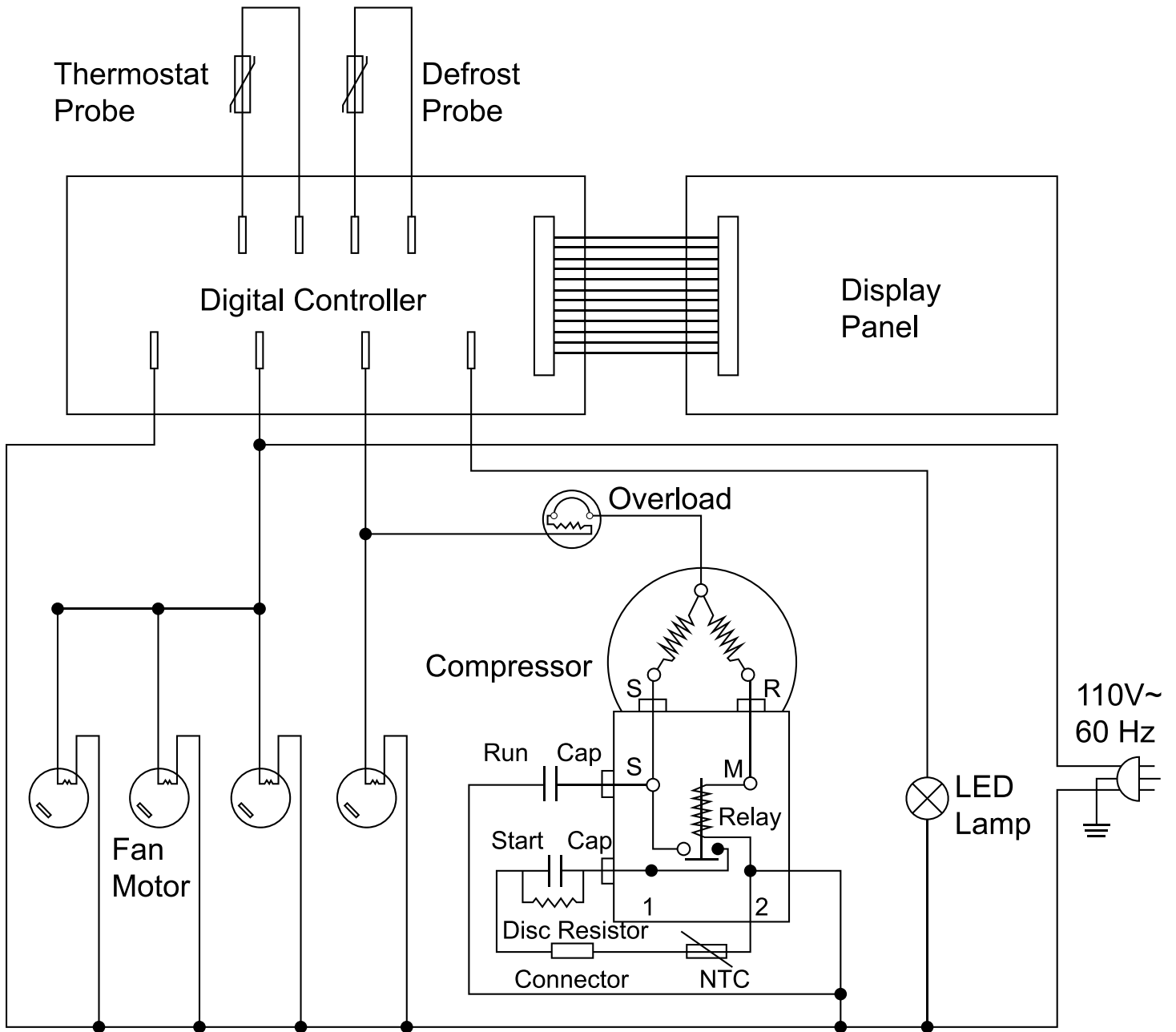



Warranty Registration

Thank you for purchasing an Omcan product. To register your warranty for this product, complete the information below, tear off the card at the perforation and then send to the address specified below. You can also register online by visiting:

Merci d'avoir acheté un produit Omcan. Pour enregistrer votre garantie pour ce produit, complétez les informations ci-dessous, détachez la carte au niveau de la perforation, puis l'envoyer à l'adresse spécifiée ci-dessous. Vous pouvez également vous inscrire en ligne en visitant:

Gracias por comprar un producto Omcan usted. Para registrar su garantía para este producto, complete la información a continuación, cortar la tarjeta en la perforación y luego enviarlo a la dirección indicada a continuación. También puede registrarse en línea en:

<https://omcan.com/warranty-registration/>

For mailing in Canada

Pour postale au Canada

Por correo en Canadá

For mailing in the US

Pour diffusion aux États-Unis

Por correo en los EE.UU.

OMCAN

PRODUCT WARRANTY REGISTRATION

3115 Pepper Mill Court,

Mississauga, Ontario

Canada, L5L 4X5

OMCAN

PRODUCT WARRANTY REGISTRATION

4450 Witmer Industrial Estates, Unit 4,

Niagara Falls, New York

USA, 14305

or email to: service@omcan.com



Purchaser's Information

Name: _____

Address: _____

City: _____ Province or State: _____ Postal or Zip: _____

Country: _____

Dealer from which Purchased: _____

Dealer City: _____ Dealer Province or State: _____

Invoice: _____

Model Name: _____ Model Number: _____

Machine Description: _____

Date of Purchase (MM/DD/YYYY): _____

Would you like to extend the warranty? Yes No

Company Name: _____

Telephone: _____

Email Address: _____

Type of Company:

Restaurant Bakery Deli

Butcher Supermarket Caterer

Institution (specify): _____

Other (specify): _____

Serial Number: _____

Date of Installation (MM/DD/YYYY): _____

Thank you for choosing Omcan | Merci d'avoir choisi Omcan | Gracias por elegir Omcan



Since 1951 Omcan has grown to become a leading distributor of equipment and supplies to the North American food service industry. Our success over these many years can be attributed to our commitment to strengthen and develop new and existing relationships with our valued customers and manufacturers. Today with partners in North America, Europe, Asia and South America, we continually work to improve and grow the company. We strive to offer customers exceptional value through our qualified local sales and service representatives who provide convenient access to over 5,000 globally sourced products.

Depuis 1951 Omcan a grandi pour devenir un des “leaders” de la distribution des équipements et matériel pour l’industrie des services alimentaires en Amérique du Nord. Notre succès au cours de ces nombreuses années peut être attribué à notre engagement à renforcer et à développer de nouvelles et existantes relations avec nos clients et les fabricants de valeur. Aujourd’hui avec des partenaires en Amérique du Nord, Europe, Asie et Amérique du Sud, nous travaillons continuellement à améliorer et développer l’entreprise. Nous nous efforçons d’offrir à nos clients une valeur exceptionnelle grâce à nos ventes locales qualifiées et des représentants de service qui offrent un accès facile à plus de 5000 produits provenant du monde entier.

Desde 1951 Omcan ha crecido hasta convertirse en un líder en la distribución de equipos y suministros de alimentos en América del Norte industria de servicios. Nuestro éxito en estos años se puede atribuir a nuestro compromiso de fortalecer y desarrollar nuevas relaciones existentes con nuestros valiosos clientes y fabricantes. Hoy con socios de América del Norte, Europa, Asia y América del Sur, que trabajan continuamente para mejorar y crecer la empresa. Nos esforzamos por ofrecer a nuestros clientes valor excepcional a través de nuestro local de ventas y representantes de los servicios que proporcionan un fácil acceso a más de 5,000 productos con origen a nivel mundial.

