



Refrigerated Showcases

Models RS-CN-0072-R*, 0400-R, 0100-R*
Items 39552*, 40440, 41466*

Instruction Manual



STOP
DO NOT RETURN
THIS PRODUCT TO THE STORE

For questions or assistance with this product call OMCAN Toll Free:
1 800 465 0234
Customer Service
or
visit the Support section of
www.omcan.com

Revised - 11/12/2019



Toll Free: 1-800-465-0234
Fax: 905-607-0234
Email: service@omcan.com
www.omcan.com

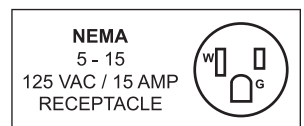

Table of Contents

Model RS-CN-0072-R / Model RS-CN-0400-R / Model RS-CN-0100-R

Section	Page
General Information -----	3 - 4
Safety and Warranty -----	4 - 6
Technical Specifications -----	6
Operation -----	7 - 8
Maintenance -----	8
Troubleshooting -----	8 - 9
Parts Breakdown -----	10 - 15
Electrical Schematics -----	16 - 18
Warranty Registration -----	19



General Information

Omcan Manufacturing and Distributing Company Inc., Food Machinery of America, Inc. dba Omcan and Omcan Inc. are not responsible for any harm or injury caused due to any person's improper or negligent use of this equipment. The product shall only be operated by someone over the age of 18, of sound mind, and not under the influence of any drugs or alcohol, who has been trained in the correct operation of this machine, and is wearing authorized, proper safety clothing. Any modification to the machine voids any warranty, and may cause harm to individuals using the machine or in the vicinity of the machine while in operation.

CHECK PACKAGE UPON ARRIVAL

Upon receipt of an Omcan shipment please inspect for external damage. If no damage is evident on the external packaging, open carton to ensure all ordered items are within the box, and there is no concealed damage to the machine. If the package has suffered rough handling, bumps or damage (visible or concealed), please note it on the bill of lading before accepting the delivery and contact Omcan within 24 hours, so we may initiate a claim with the carrier. A detailed report on the extent of the damage caused to the machine must be filled out within three days, from the delivery date shown in the shipping documents. Omcan has no recourse for damaged products that were shipped collect or third party.

Before operating any equipment, always read and familiarize yourself with all operation and safety instructions.

Omcan would like to thank you for purchasing this machine. It's of the utmost importance to save these instructions for future reference. Also save the original box and packaging for shipping the equipment if servicing or returning of the machine is required.

Omcan Fabrication et distribution Compañie Limité et Food Machinery d'Amérique, dba Omcan et Omcan Inc. ne sont pas responsables de tout dommage ou blessure causé du fait que toute personne ait utilisé cet équipement de façon irrégulière. Le produit ne doit être exploité que par quelqu'un de plus de 18 ans, saine d'esprit, et pas sous l'influence d'une drogue ou d'alcool, qui a été formé pour utiliser cette machine correctement, et est vêtu de vêtements de sécurité approprié. Toute modification de la machine annule toute garantie, et peut causer un préjudice à des personnes utilisant la machine ou des personnes à proximité de la machine pendant son fonctionnement.

VÉRIFIEZ LE COLIS DÈS RÉCEPTION

Dès réception d'une expédition d'Omcan veuillez inspecter pour dommages externes. Si aucun dommage n'est visible sur l'emballage externe, ouvrez le carton afin de s'assurer que tous les éléments commandés sont dans la boîte, et il n'y a aucun dommage dissimulé à la machine. Si le colis n'a subi aucune mauvaises manipulations, de bosses ou de dommages (visible ou cachée), notez-le sur le bond de livraison avant d'accepter la livraison et contactez Omcan dans les 24 heures qui suivent, pour que nous puissions engager une réclamation auprès du transporteur. Un rapport détaillé sur l'étendue des dommages causés à la machine doit être rempli dans un délai de trois jours, à compter de la date de livraison indiquée dans les documents d'expédition. Omcan n'a aucun droit de recours pour les produits endommagés qui ont été expédiés ou cueilli par un tiers transporteur.

General Information

Avant d'utiliser n'importe quel équipement, toujours lire et vous familiariser avec toutes les opérations et les consignes de sécurité.

Omcan voudrais vous remercier d'avoir choisi cette machine. Il est primordial de conserver ces instructions pour une référence ultérieure. Également conservez la boîte originale et l'emballage pour l'expédition de l'équipement si l'entretien ou le retour de la machine est nécessaire.

Omcan Empresa De Fabricacion Y Distribucion Inc. Y Maquinaria De Alimentos De America, Inc. dba Omcan y Omcan Inc. no son responsables de ningun daño o perjuicio causado por cualquier persona inadecuada o el uso descuidado de este equipo. El producto solo podra ser operado por una persona mayor de 18 años, en su sano juicio y no bajo alguna influencia de droga o alcohol, y que este ha sido entrenado en el correcto funcionamiento de esta máquina, y ésta usando ropa apropiada y autorizada. Cualquier modificación a la máquina anula la garantía y puede causar daños a las personas usando la máquina mientras esta en el funcionamiento.

REVISE EL PAQUETE A SU LLEGADA

Tras la recepcion de un envio Omcan favor inspeccionar daños externos. Si no hay daños evidentes en el empaque exterior, Habra el carton para asegurarse que todos los articulos solicitados estén dentro de la caja y no encuentre daños ocultos en la máquina. Si el paquete ha sufrido un manejo de poco cuidado, golpes o daños (visible o oculto) por favor anote en la factura antes de aceptar la entrega y contacte Omcan dentro de las 24 horas, de modo que podamos iniciar una reclamación con la compañía. Un informe detallado sobre los daños causados a la máquina debe ser llenado en el plazo de tres días, desde la fecha de entrega que se muestra en los documentos de envío. Omcan no tiene ningun recurso por productos dañados que se enviaron a recoger por terceros.

Antes de utilizar cualquier equipo, siempre lea y familiarizarse con todas las instrucciones de funcionamiento y seguridad.

Omcan le gustaría darle las gracias por la compra de esta máquina. Es de la mayor importancia para salvar estas instrucciones para futuras consultas. Además, guarda la caja original y el embalaje para el envío del equipo si servicio técnico o devolución de la máquina que se requiere.

Safety and Warranty

HANDLING AND INSTALLATION

Handle with care Unplug wall socket before moving. Never tilt the refrigerator over 45 degrees during handling.	Storage Always store the refrigerator in a dry place.
---	---



Safety and Warranty

Sufficient space To allow for proper air circulation and increased refrigeration capabilities, the refrigerator must have at least 4 inches of space between wall and unit.	Proper ventilation Always place the refrigerator in an area with good ventilation. For first time use, wait at least 2 hours before plugging into wall socket.
Away from heat source Never place the refrigerator near any type of heat source or in direct sunlight, as it reduces refrigeration capabilities.	No heavy load Never put heavy items on top of the refrigerator.
No altercations/tampering Never tamper with or make changes to the refrigerator. Changes and add-ons should not be installed to the inside or outside of the refrigerator.	Stable location Unpack and place the refrigerator on flat, solid ground.

PREPARATION AND POWER SUPPLY

Exclusive power outlet Power supply should be 115-120V, single phase AC with exclusive single phase three pin outlet (250V/10A) and fuse (6A). The power outlet must be in close proximity to the ground.	No shared power outlets Refrigerator cable should never share the power outlet with any other appliance, as cable will overheat and may result in a fire.
Protect cables Extra caution should be used when handling cables, as broken or damaged cables can cause sparking and may result in a fire.	No water flushing Never flush the refrigerator surface. This can cause leakage, which may result in electrical damage or fire.
Never store flammables and explosives No explosives or flammables should be stored in, or in proximity to, the refrigerator, such as gasoline, alcohol, and adhesives.	No spray Never spray flammables such as paint or coating near the refrigerator. This may cause fire or malfunction.
After power outage After a power outage or the unplugging of the refrigerator, wait at least 5 minutes before plugging it back in.	No medicine Medicine should not be stored inside of the refrigerator.

1 YEAR PARTS AND LABOUR WARRANTY

Within the warranty period, contact Omcan Inc. at 1-800-465-0234 to schedule an Omcan authorized service technician to repair the equipment locally.

Unauthorized maintenance will void the warranty. Warranty covers electrical and part failures, not improper use.

Please see <https://omcan.com/disclaimer> for complete info.

Safety and Warranty

WARNING:

The packaging components are classified as normal solid urban waste and can therefore be disposed of without difficulty.

In any case, for suitable recycling, we suggest disposing of the products separately (differentiated waste) according to the current norms.

DO NOT DISCARD ANY PACKAGING MATERIALS IN THE ENVIRONMENT!

Technical Specifications

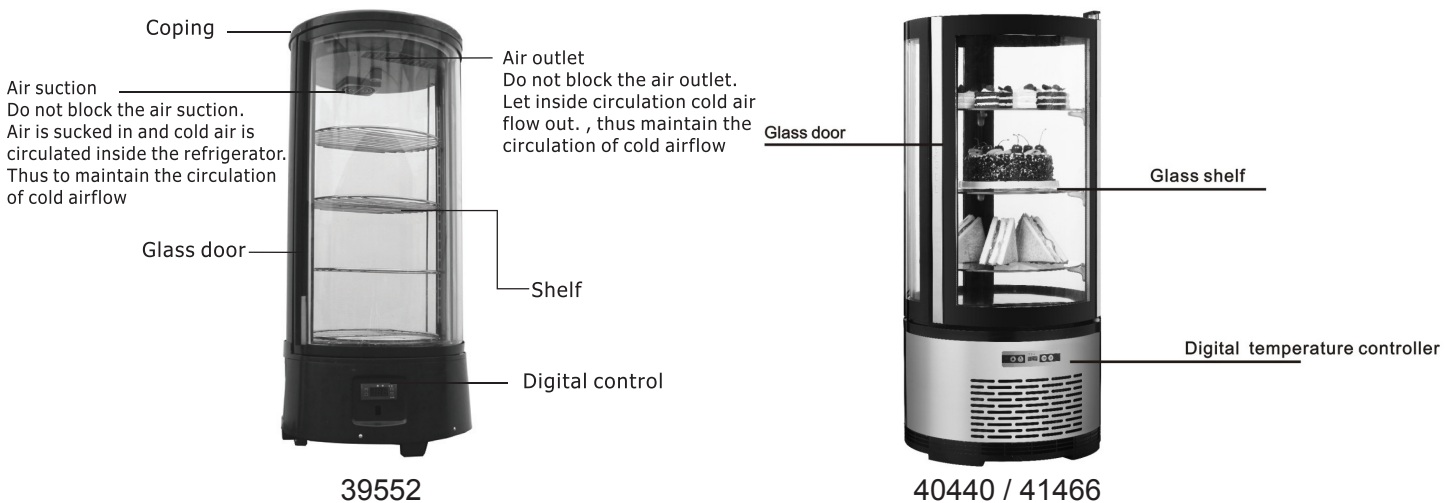

Model	RS-CN-0072-R	RS-CN-0400-R	RS-CN-0100-R
Capacity	72 L / 2.54 cu. ft.	400 L / 14.1 cu. ft.	100 L / 3.53 cu. ft.
Power	0.17 kW	0.50 kW	0.23 kW
Electrical	110V / 60Hz / 1Ph		
Refrigerant	R134a		
Lamp Power	1.5 W x 2 (LED)	5 W x 2 (LED)	6 W
Type of Climate	N		6
Rated Current	1.34A / 1.2A	6A	2.6A
Temperature Range	0 - 12°C / 32 - 50°F	2 - 8°C / 35.6 - 46.4°F	
Maximum Load	22 lbs. / 10 kgs.	88.2 lbs. / 40 kgs.	44 lbs. / 20 kgs.
Dimensions	17.7" x 17.7" x 38.7" 450 x 450 x 983mm	26.8" x 26.8" x 68.9" 681 x 681 x 1750mm	18.9" x 18.9" x 40.6" 480 x 480 x 1030mm
Weight	84.9 lbs. / 38.5 kgs.	275 lbs. / 124.7 kgs.	110 lbs. / 49.9 kgs.
Item Number	39552	40440	41466

The device is installed with an enclosed compressor with refrigerant R134a which has been indicated as an environmentally friendly agent. The product is operated under an air cooling system, maintaining the body temperature evenly.

1. Double hollow transparent glasses are used on the door and body, it features an artistic and elegant appearance, perfect perspective and easy access.
2. The device is commonly for commercial use, such as restaurants, convenience stores, clubs, ect.

BEFORE USE

- Plug refrigerator into the 115-120V exclusive socket.
- After the refrigerator is running, confirm that air suction/filtration is in order and that it is sufficiently cold. After checking to make sure the refrigerator is working properly, it may be used.

DIGITAL TEMPERATURE CONTROLLER

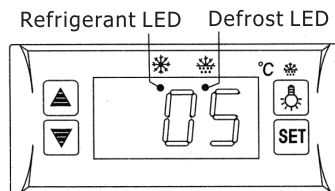

FEATURES OF FUNCTION

- Small, integrated digital controller, which is applicable to the compressor of 1 Hp.
- Main functions are: Temperature Display/Temperature Control/Manual-Automatic /Light Control/Value Storing/Self-Testing/Parameter Locking.

FRONT PANEL OPERATION

3. Set temperature: Press **SET** button; set temperature will be displayed. Press **▲** or **▼** button to modify and store the displayed value. Press **SET** button to exit the adjustment and display the cold-room temperature.
4. If no button is pressed within 10 seconds, the cold-room temperature will be displayed.
5. Lighting: Press **☞** button to activate light in refrigerator; press again to turn off. Manual start/stop defrost: Press **☞** button and hold for 6 seconds to either defrost or to stop defrost.
6. Refrigeration LED: During refrigeration, the LED is on. When the cold room temperature is constant, the LED is off. During delay start, the LED flashes.
7. Defrost LED: During defrosting, the LED is on. When it stops defrosting, the LED is off. During the delay of defrost, the LED flashed.

CAUTION

- Minimizing time the time and frequency that the door is open will maintain temperature.
- Never block the air outlet and suction to keep the air circulation and refrigeration capability constant.

Operation

- Do not overfill refrigerator with food, as it will influence the cooling effect. If needed, adjust the rack height for proper food storage.
- Cool down hot food to room temperature before placing inside the refrigerator.
- When power supply has been cut off, reduce opening times and maintain cool temperature in refrigerator.
- To avoid scalding, never touch the compressor.
- If the supply cord is damaged, it must be replaced by the manufacturer, its service agent, or similarly qualified persons in order to avoid hazard.
- This appliance is not intended for use by persons (including children) with reduced physical, sensory or mental capabilities, or lack of experience and knowledge, unless they have been given supervision or instruction concerning use of the appliance by a person responsible for their safety.
- Children should be supervised to ensure that they do not play with the appliance.

Maintenance

1. Cabinet Cleaning:
 - a. The product should be maintained and cleaned periodically with power supply disconnected. In cleaning, please use mild-rinsing water or non-corrosive products. Do not wash directly with water faucet.
 - b. Clean outside of unit using a soft cloth with neutral detergent, and dry with a separate soft cloth.
 - c. Clean inside racks by removing them from the unit and clean with water.
2. When shutting down unit for a long period of time, take out all food and unplug wall socket. Clean inside and outside thoroughly, and keep door open to sufficiently dry.
3. As glass breaks easily, keep far away from children.
4. Frequently observe the operation of the product. In case of any abnormal noise or smell, cut off the power supply immediately and call professionals. Do not restart the product before source of trouble is found.
5. We will not be responsible for any accidents acquired through failure to follow previous notices.

Troubleshooting

Trouble	Cause and Remedy
No Refrigeration	Is the plug securely in the socket?
	Is the fuse broken?
	Is there no power?

Troubleshooting

Poor Refrigeration	Is it under sunlight? Is there any heat source nearby?
	Is the surrounding ventilation poor?
	Is the door seal strip deformed or damaged?
	Is the food congested or is there too much food?
	Does food block the air suction or outlet?
	Regulate the temperature controller.
Noisy	The refrigerator is not level.
	The refrigerator is making contact with the wall or other objects.
	There is a loose part in the refrigerator.
Contact Omcan for help if simple trouble shooting does not solve the problems.	

NOTE

Following occurrences are not problems:

- The murmur of water is heard when the refrigerator is working. It is a normal occurrence as the coolant is circulating in the system.
- When the weather is damp, condensation might be found on the outside of the refrigerator. It is caused by high humidity. Simply use cloth to wipe it off.

REFERENCE

Item Number	Model Number	Description	Manufacturer Model Number
39552	RS-CN-0072-R	Refrigerated Showcase Countertop Cylinder 72 L / 2.5 cu. ft. cQPSus ETL Sanitation	RTC-72L
40440	RS-CN-0400-R	Refrigerated Showcase Cylinder 400 L / 14.1 cu. ft. cQPSus	ARC-400R
41466	RS-CN-0100-R	Refrigerated Showcase Cylinder 100 L / 3.53 cu. ft. 110V/60/1 cQPS ETL Sanitation	ARC-100R

Parts Breakdown

Model RS-CN-0072-R 39552

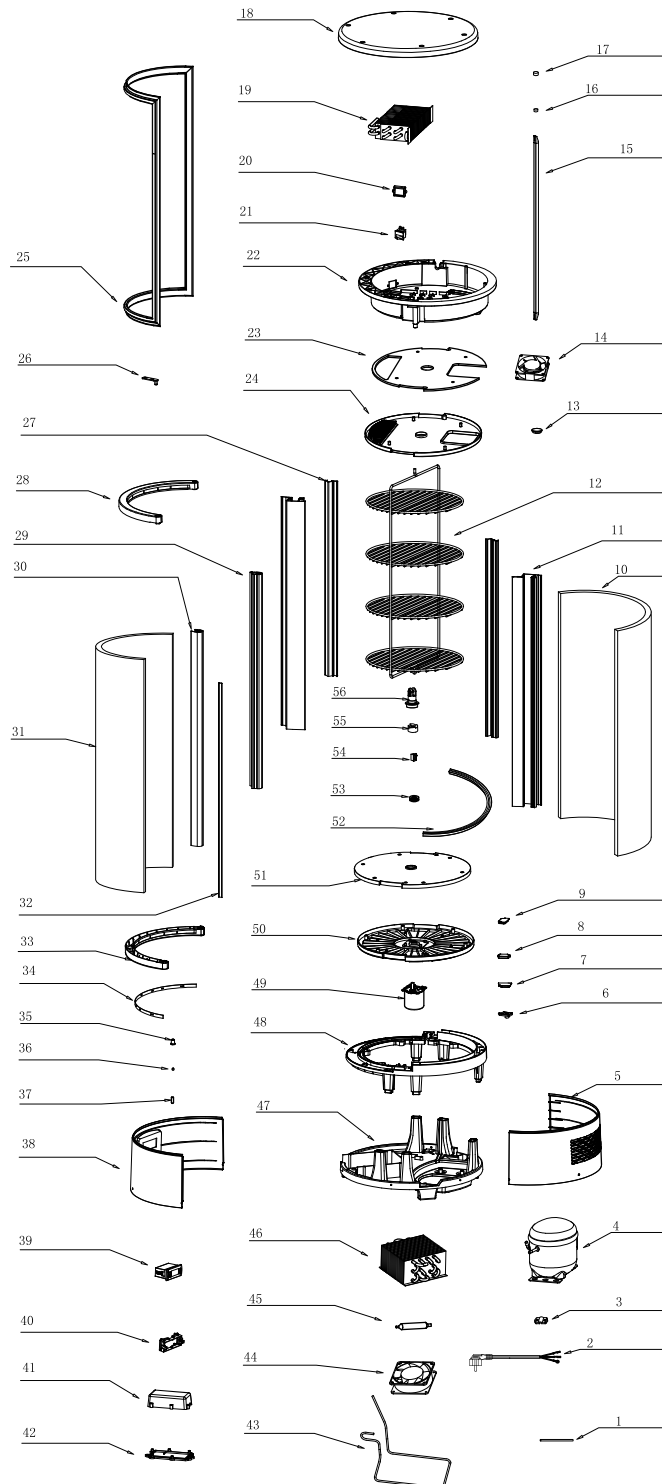

Parts Breakdown

Model RS-CN-0072-R 39552

Item No.	Description	Position	Item No.	Description	Position	Item No.	Description	Position
71320	Charging Tube for RTC72L	1	71339	Door Switch Unit for RTC72L	20	71358	Mainboard for RTC72L	39
30621	Power Cord for RTC72L	2	71340	Door Switch for RTC72L	21	71359	Clip for Controller for RTC72L	40
71322	Wire Clip Cover for RTC72L	3	71341	Evaporator Holder for RTC72L	22	71360	Circuit Board Box for RTC72L	41
71323	Compressor for RTC72L	4	71342	Insulation Sheet for RTC72L	23	71361	Box Cover for RTC72L	42
71324	Rear Base Panel for RTC72L	5	71343	Ventilated Tray for RTC72L	24	71362	Copper Pipe for RTC72L	43
71325	Door Washer for RTC72L	6	71344	Door Gasket for RTC72L	25	71363	Condenser Fan for RTC72L	44
71326	Washer 1 for RTC72L	7	71345	Upper Gemel for RTC72L	26	71364	Dry Filter for RTC72L	45
71327	Washer 2 for RTC72L	8	71346	Pillar Decoration for RTC72L	27	71365	Condenser for RTC72L	46
71328	Washer 3 for RTC72L	9	71347	Upper Door Frame for RTC72L	28	71366	Bottom Base of Compressor for RTC72L	47
71329	Rear Glass for RTC72L	10	71348	Door Handle for RTC72L	29	71367	Fixed Tray for RTC72L	48
71330	Pillar for RTC72L	11	71349	Bottom Door Frame for RTC72L	30	71368	Motor for the Rotational Rack for RTC72L	49
71331	Rotate Shelf for RTC72L	12	71350	Door Glass for RTC72L	31	71369	Bottom Cover of Fixed Tray for RTC72L	50
71332	Cap of Evaporator Holder for RTC72L	13	71351	Side Magnetic Strip for RTC72L	32	71370	Upper Cover of Fixed Tray for RTC72L	51
71333	Fan Motor for Evaporator for RTC72L	14	71352	Bottom Door Frame for RTC72L	33	71371	Seal for RTC72L	52
71334	LED Lamp for RTC72L	15	71353	Magnetic Strip for RTC72L	34	71372	Plane Bearing for RTC72L	53
71335	Small Cap for RTC72L	16	71354	Bush for RTC72L	35	71373	Switch for RTC72L	54
71336	Screw Cover for RTC72L	17	71355	Steel Ball for RTC72L	36	71374	Lower Clutch for RTC72L	55
71337	Top Cover for RTC72L	18	71356	Door Pin for RTC72L	37	71375	Upper Clutch for RTC72L	56
71338	Evaporator for RTC72L	19	71357	Front Panel for RTC72L	38			

Parts Breakdown

Model RS-CN-0400-R 40440

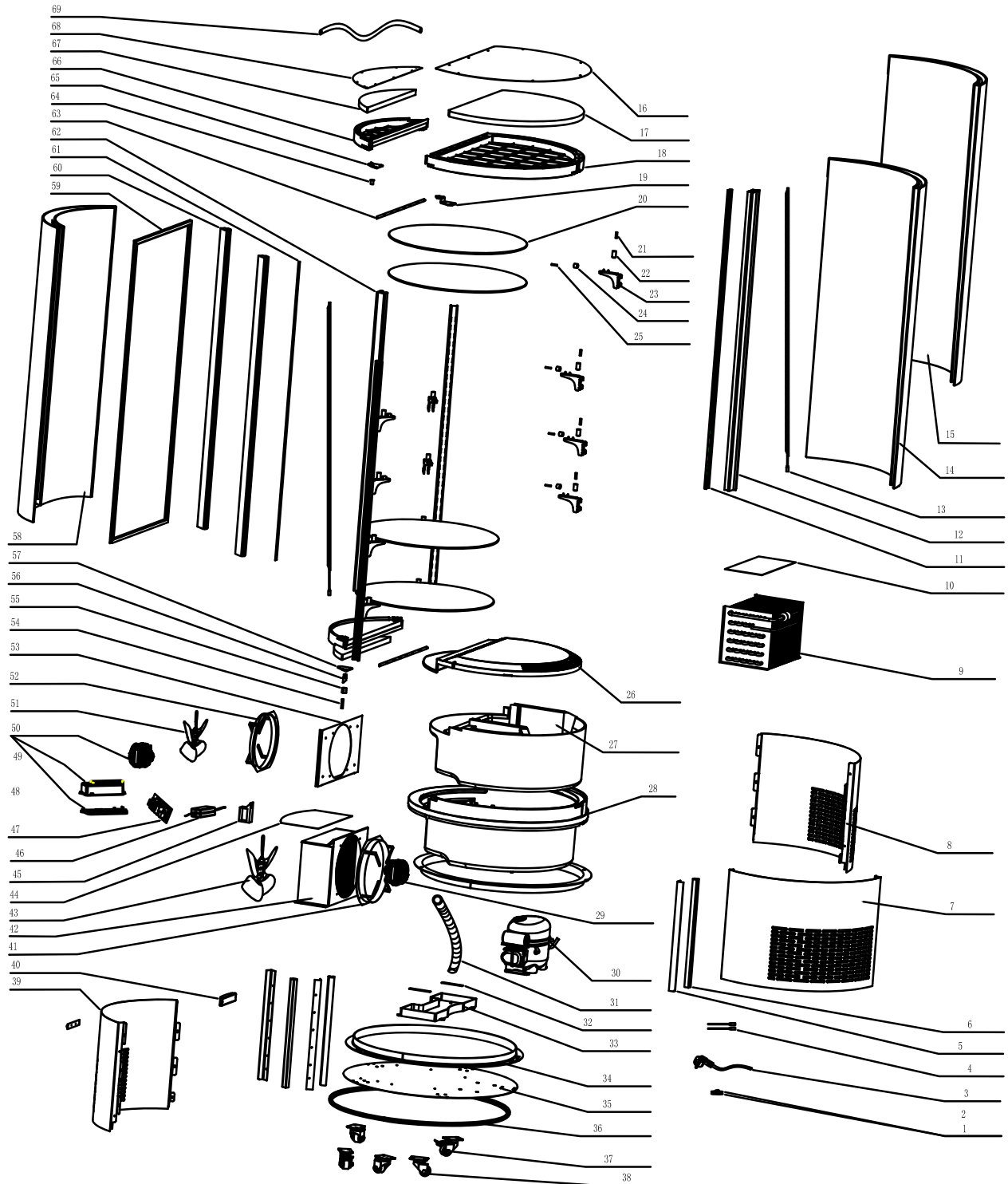

Parts Breakdown

Model RS-CN-0400-R 40440

Item No.	Description	Position	Item No.	Description	Position	Item No.	Description	Position
30621	Power Cord for ARC400R	1 - 3	71276	Ventilation Cover for ARC400R	26	71299	PCB Box for ARC400R	49
71254	LED Cord for ARC400R	4	71277	Insulation for ARC400R	27	71300	Evaporator Motor for ARC400R	50
71255	Angle Iron for ARC400R	5	71278	Plastic Base for ARC400R	28	71301	Evaporator Fan Blade for ARC400R	51
71256	Trim Strip for ARC400R	6	71279	Condenser Motor for ARC400R	29	71302	Evaporator Flange for ARC400R	52
71257	Left Panel for ARC400R	7	71280	Compressor for ARC400R	30	71303	Evaporator Fixer for ARC400R	53
71258	Right Panel for ARC400R	8	71281	Drain Tube for ARC400R	31	71304	Door Shaft for ARC400R	54
71259	Evaporator for ARC400R	9	71282	Fixer for ARC400R	32	71305	Bottom Door Closer for ARC400R	55
71260	Evaporator Cover for ARC400R	10	71283	Drip Tray for ARC400R	33	71306	Top Door Closer for ARC400R	56
71261	Shelf Holder for ARC400R	11	71284	Angle Iron Flange for ARC400R	34	71307	Hinge Fixer for ARC400R	57
71262	Middle Pole for ARC400R	12	71285	Bottom Plate for ARC400R	35	71308	Door Glass for ARC400R	58
71263	LED for ARC400R	13	71286	Strip for ARC400R	36	71309	Door Seal for ARC400R	59
71264	Left Glass for ARC400R	14	71287	Front Caster for ARC400R	37	71310	Door Pole for ARC400R	60
71265	Right Glass for ARC400R	15	71288	Rear Caster for ARC400R	38	71311	Door Stopper 1 for ARC400R	61
71266	Top Cover for ARC400R	16	71289	Front Panel for ARC400R	39	71312	Side Pole for ARC400R	62
71267	Top Insulation for ARC400R	17	71290	Displayer Cover for ARC400R	40	71313	Door Stopper 2 for ARC400R	63
71268	Top Plastic Cover for ARC400R	18	71291	Condenser Flange for ARC400R	41	71314	Hinge Sleeve for ARC400R	64
71269	Top Hinge Fixer for ARC400R	19	71292	Condenser for ARC400R	42	71315	Bottom Shaft Plate for ARC400R	65
71270	Class Shelf for ARC400R	20	71293	Fan Blade for ARC400R	43	71316	Door Frame for ARC400R	66
71271	Roller Shaft for ARC400R	21	71294	Condenser Cover for ARC400R	44	71317	Door Insulation for ARC400R	67
71272	Roller for ARC400R	22	71295	LED Power Holder for ARC400R	45	71318	Door Cover for ARC400R	68
71273	Bracket for ARC400R	23	71296	LED Power for ARC400R	46	71319	Water Tube for ARC400R	69
71274	Roller 2 for ARC400R	24	71297	Electron Control for ARC400R	47			
71275	Roller Shaft 2 for ARC400R	25	71298	PCB Cover for ARC400R	48			

Parts Breakdown

Model RS-CN-0100-R 41466

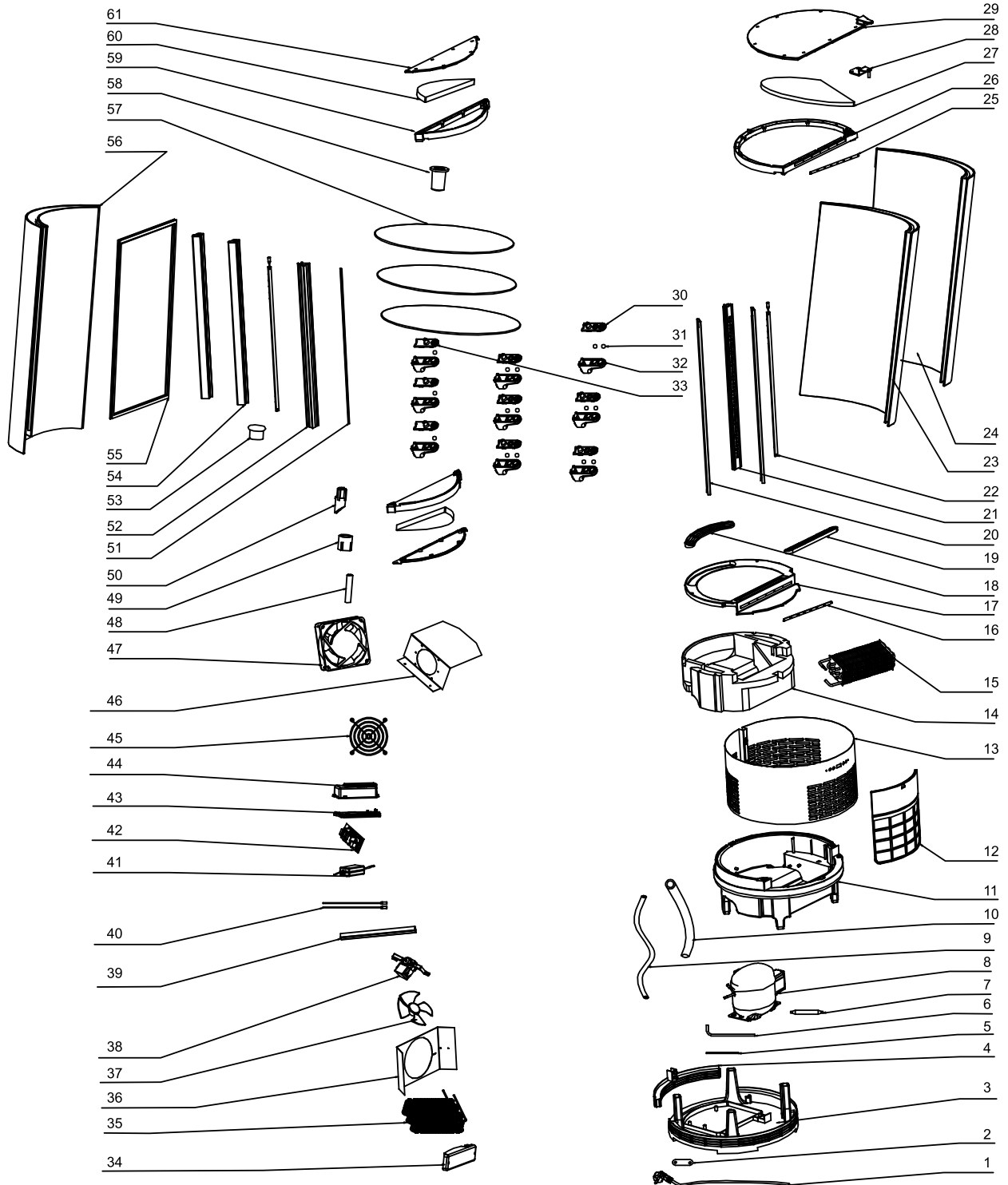

Parts Breakdown

Model RS-CN-0100-R 41466

Item No.	Description	Position	Item No.	Description	Position	Item No.	Description	Position
30621	Power Cord for ARC100R	1 - 2	71211	LED Light for ARC100R	22	71231	Digital Controller for ARC100R	42
71192	Plastic Base for ARC100R	3	71212	Left Glass for ARC100R	23	71232	Base Panel of Controller for ARC100R	43
71193	Bottom Frame for ARC100R	4	71213	Right Glass for ARC100R	24	71233	Controller Cover for ARC100R	44
71194	Accumulator for ARC100R	5	71214	Horizontal Door Stopper for ARC100R	25	71234	Fan Net for ARC100R	45
71195	Gas Return Pipe for ARC100R	6	71215	Top Plastic Cover for ARC100R	26	71235	Evaporator Fixer for ARC100R	46
71196	Dry Filter for ARC100R	7	71216	Top Insulation for ARC100R	27	71236	Evaporator Motor for ARC100R	47
71197	Compressor for ARC100R	8	71217	Top Hinge Fixer for ARC100R	28	71237	Lower Door Shaft for ARC100R	48
71198	Small Water Pipe for ARC100R	9	71218	Top Cover for ARC100R	29	71238	Bottom Door Closer for ARC100R	49
71199	Large Water Pipe for ARC100R	10	71219	Cover of a Double Hole for ARC100R	30	71239	Top Door Closer for ARC100R	50
71200	Plastic Base for ARC100R	11	71220	Roller for ARC100R	31	71240	Vertical Door Stopper for ARC100R	51
71201	Filter Screen for ARC100R	12	71221	Bracket for ARC100R	32	71241	Side Pole for ARC100R	52
71202	Round Frame for ARC100R	13	71222	Cover of a Single Span for ARC100R	33	71242	Door Cover Plug for ARC100R	53
71203	Middle Insulation for ARC100R	14	71223	Switch Cover for ARC100R	34	71243	Door Pole for ARC100R	54
71204	Evaporator for ARC100R	15	71224	Condenser for ARC100R	35	71244	Door Seal for ARC100R	55
71205	Horizontal Door Stopper for ARC100R	16	71225	Condenser Fixer for ARC100R	36	71245	Curved Door Glass for ARC100R	56
71206	Ventilation Cover for ARC100R	17	71226	Condenser Fan Blade for ARC100R	37	71246	Put Aside Frame Glass for ARC100R	57
71207	Cover of Air Outlet for ARC100R	18	71227	Condenser Motor for ARC100R	38	71247	Hinge Sleeve for ARC100R	58
71208	Cover of Air Suction for ARC100R	19	71228	Decorating Strip for ARC100R	39	71248	Door Frame for ARC100R	59
71209	Decorating Pole for ARC100R	20	71229	LED Cord for ARC100R	40	71249	Door Insulation for ARC100R	60
71210	Middle Pole for ARC100R	21	71230	LED Power for ARC100R	41	71250	Door Cover for ARC100R	61

Electrical Schematics

Model RS-CN-0072-R 39552

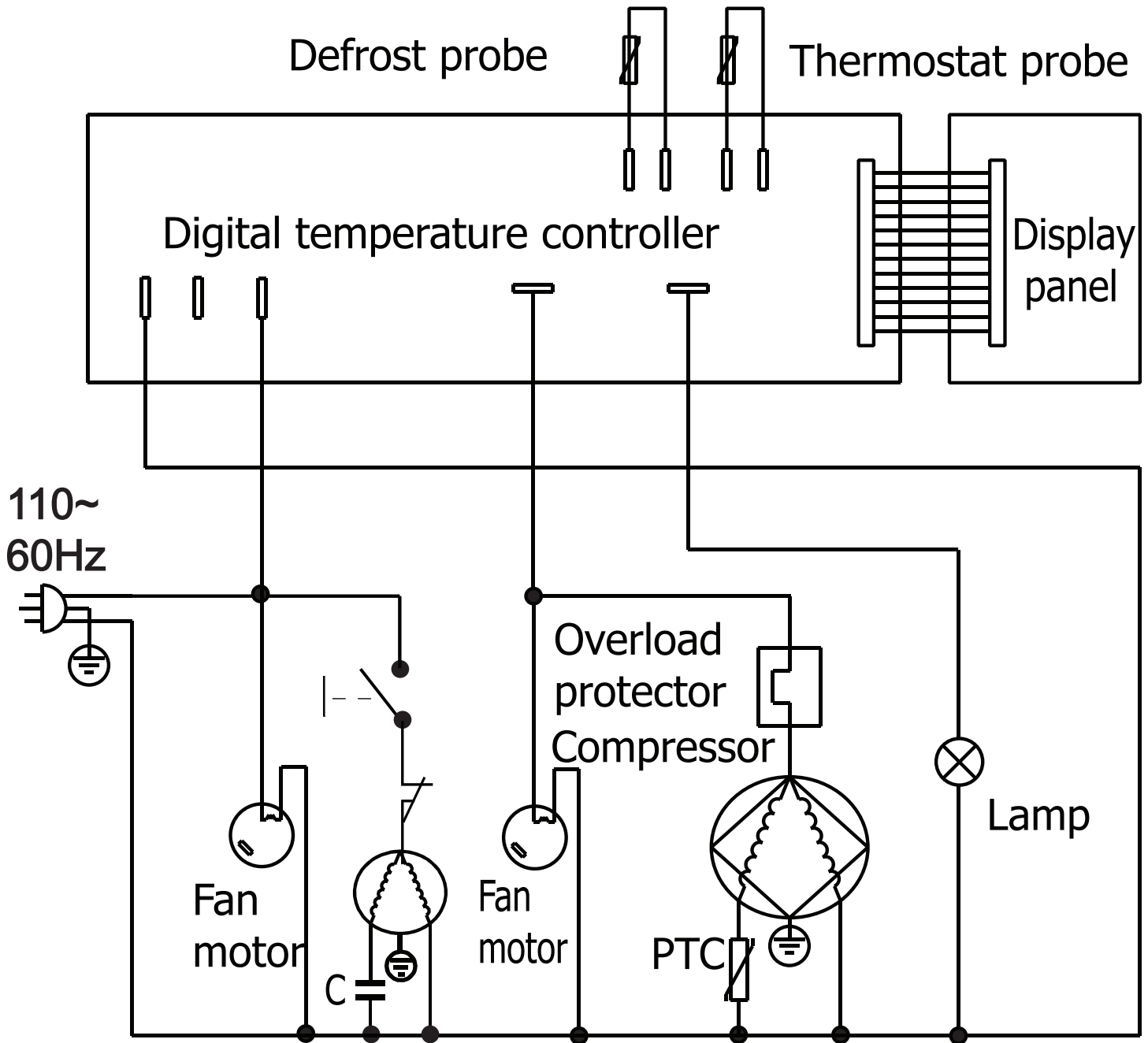

Electrical Schematics

Model RS-CN-0400-R 40440

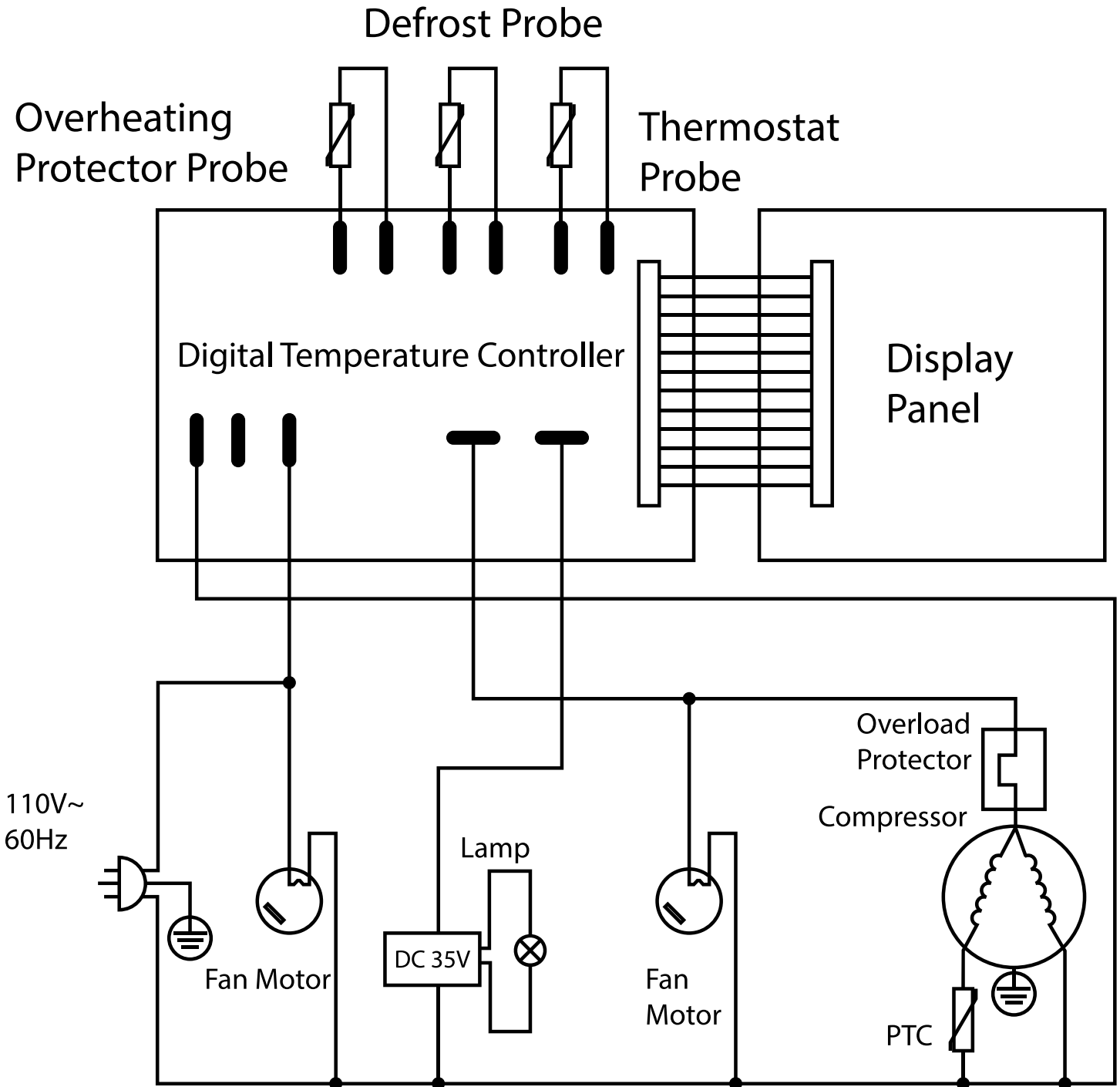

Electrical Schematics

Model RS-CN-0100-R 41466

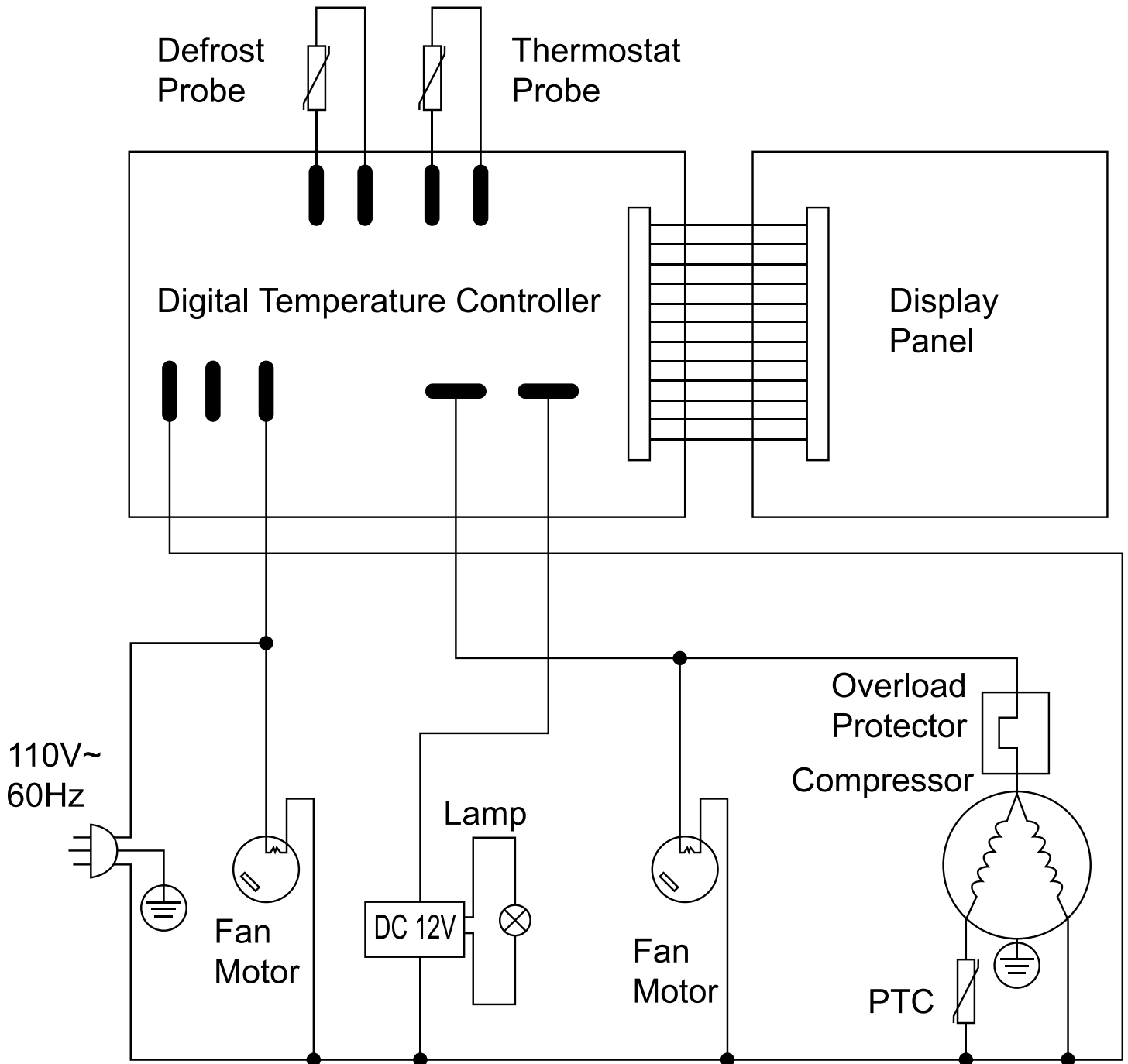



Warranty Registration

Thank you for purchasing an Omcan product. To register your warranty for this product, complete the information below, tear off the card at the perforation and then send to the address specified below. You can also register online by visiting:

Merci d'avoir acheté un produit Omcan. Pour enregistrer votre garantie pour ce produit, complétez les informations ci-dessous, détachez la carte au niveau de la perforation, puis l'envoyer à l'adresse spécifiée ci-dessous. Vous pouvez également vous inscrire en ligne en visitant:

Gracias por comprar un producto Omcan usted. Para registrar su garantía para este producto, complete la información a continuación, cortar la tarjeta en la perforación y luego enviarlo a la dirección indicada a continuación. También puede registrarse en línea en:

<https://omcan.com/warranty-registration/>

For mailing in Canada

Pour postale au Canada

Por correo en Canadá

OMCAN

PRODUCT WARRANTY REGISTRATION

3115 Pepper Mill Court,

Mississauga, Ontario

Canada, L5L 4X5

For mailing in the US

Pour diffusion aux États-Unis

Por correo en los EE.UU.

OMCAN

PRODUCT WARRANTY REGISTRATION

4450 Witmer Industrial Estates, Unit 4,

Niagara Falls, New York

USA, 14305

or email to: service@omcan.com



Purchaser's Information

Name: _____

Address: _____

City: _____ Province or State: _____ Postal or Zip: _____

Country: _____

Dealer from which Purchased: _____

Dealer City: _____ Dealer Province or State: _____

Invoice: _____

Model Name: _____ Model Number: _____

Machine Description: _____

Date of Purchase (MM/DD/YYYY): _____

Would you like to extend the warranty? Yes No

Company Name: _____

Telephone: _____

Email Address: _____

Type of Company:

Restaurant Bakery Deli

Butcher Supermarket Caterer

Institution (*specify*): _____

Other (*specify*): _____

Serial Number: _____

Date of Installation (MM/DD/YYYY): _____

Thank you for choosing Omcan | Merci d'avoir choisi Omcan | Gracias por elegir Omcan



Since 1951 Omcan has grown to become a leading distributor of equipment and supplies to the North American food service industry. Our success over these many years can be attributed to our commitment to strengthen and develop new and existing relationships with our valued customers and manufacturers. Today with partners in North America, Europe, Asia and South America, we continually work to improve and grow the company. We strive to offer customers exceptional value through our qualified local sales and service representatives who provide convenient access to over 5,000 globally sourced products.

Depuis 1951 Omcan a grandi pour devenir un des “leaders” de la distribution des équipements et matériel pour l’industrie des services alimentaires en Amérique du Nord. Notre succès au cours de ces nombreuses années peut être attribué à notre engagement à renforcer et à développer de nouvelles et existantes relations avec nos clients et les fabricants de valeur. Aujourd’hui avec des partenaires en Amérique du Nord, Europe, Asie et Amérique du Sud, nous travaillons continuellement à améliorer et développer l’entreprise. Nous nous efforçons d’offrir à nos clients une valeur exceptionnelle grâce à nos ventes locales qualifiées et des représentants de service qui offrent un accès facile à plus de 5000 produits provenant du monde entier.

Desde 1951 Omcan ha crecido hasta convertirse en un líder en la distribución de equipos y suministros de alimentos en América del Norte industria de servicios. Nuestro éxito en estos años se puede atribuir a nuestro compromiso de fortalecer y desarrollar nuevas relaciones existentes con nuestros valiosos clientes y fabricantes. Hoy con socios de América del Norte, Europa, Asia y América del Sur, que trabajan continuamente para mejorar y crecer la empresa. Nos esforzamos por ofrecer a nuestros clientes valor excepcional a través de nuestro local de ventas y representantes de los servicios que proporcionan un fácil acceso a más de 5,000 productos con origen a nivel mundial.

