



Pasta Machine
Model PM-IT-0080
Item 13286
Instruction Manual



Revised - 08/21/2017



Toll Free: 1-800-465-0234
Fax: 905-607-0234
Email: service@omcan.com
www.omcan.com



Table of Contents

Model PM-IT-0080

Section	Page
General Information -----	3 - 4
Safety and Warranty -----	4 - 6
Technical Specifications -----	6
Installation -----	6 - 8
Operation -----	8 - 11
Maintenance -----	11 - 13
Troubleshooting -----	13 - 14
Figure Drawings -----	14 - 21
Parts Breakdown -----	22 - 25
Electrical Schematics -----	26 - 30
Warranty Registration -----	31



General Information

Omcan Manufacturing and Distributing Company Inc., Food Machinery of America, Inc. dba Omcan and Omcan Inc. are not responsible for any harm or injury caused due to any person's improper or negligent use of this equipment. The product shall only be operated by someone over the age of 18, of sound mind, and not under the influence of any drugs or alcohol, who has been trained in the correct operation of this machine, and is wearing authorized, proper safety clothing. Any modification to the machine voids any warranty, and may cause harm to individuals using the machine or in the vicinity of the machine while in operation.

CHECK PACKAGE UPON ARRIVAL

Upon receipt of an Omcan shipment please inspect for external damage. If no damage is evident on the external packaging, open carton to ensure all ordered items are within the box, and there is no concealed damage to the machine. If the package has suffered rough handling, bumps or damage (visible or concealed), please note it on the bill of lading before accepting the delivery and contact Omcan within 24 hours, so we may initiate a claim with the carrier. A detailed report on the extent of the damage caused to the machine must be filled out within three days, from the delivery date shown in the shipping documents. Omcan has no recourse for damaged products that were shipped collect or third party.

Before operating any equipment, always read and familiarize yourself with all operation and safety instructions.

Omcan would like to thank you for purchasing this machine. It's of the utmost importance to save these instructions for future reference. Also save the original box and packaging for shipping the equipment if servicing or returning of the machine is required.

Omcan Fabrication et distribution Compañie Limité et Food Machinery d'Amérique, dba Omcan et Omcan Inc. ne sont pas responsables de tout dommage ou blessure causé du fait que toute personne ait utilisé cet équipement de façon irrégulière. Le produit ne doit être exploité que par quelqu'un de plus de 18 ans, saine d'esprit, et pas sous l'influence d'une drogue ou d'alcool, qui a été formé pour utiliser cette machine correctement, et est vêtu de vêtements de sécurité approprié. Toute modification de la machine annule toute garantie, et peut causer un préjudice à des personnes utilisant la machine ou des personnes à proximité de la machine pendant son fonctionnement.

VÉRIFIEZ LE COLIS DÈS RÉCEPTION

Dès réception d'une expédition d'Omcan veuillez inspecter pour dommages externes. Si aucun dommage n'est visible sur l'emballage externe, ouvrez le carton afin de s'assurer que tous les éléments commandés sont dans la boîte, et il n'y a aucun dommage dissimulé à la machine. Si le colis n'a subi aucune mauvaises manipulations, de bosses ou de dommages (visible ou cachée), notez-le sur le bond de livraison avant d'accepter la livraison et contactez Omcan dans les 24 heures qui suivent, pour que nous puissions engager une réclamation auprès du transporteur. Un rapport détaillé sur l'étendue des dommages causés à la machine doit être rempli dans un délai de trois jours, à compter de la date de livraison indiquée dans les documents d'expédition. Omcan n'a aucun droit de recours pour les produits endommagés qui ont été expédiés ou cueilli par un tiers transporteur.

General Information

Avant d'utiliser n'importe quel équipement, toujours lire et vous familiariser avec toutes les opérations et les consignes de sécurité.

Omcan voudrais vous remercier d'avoir choisi cette machine. Il est primordial de conserver ces instructions pour une référence ultérieure. Également conservez la boîte originale et l'emballage pour l'expédition de l'équipement si l'entretien ou le retour de la machine est nécessaire.

Omcan Empresa De Fabricacion Y Distribucion Inc. Y Maquinaria De Alimentos De America, Inc. dba Omcan y Omcan Inc. no son responsables de ningun daño o perjuicio causado por cualquier persona inadecuada o el uso descuidado de este equipo. El producto solo podra ser operado por una persona mayor de 18 años, en su sano juicio y no bajo alguna influencia de droga o alcohol, y que este ha sido entrenado en el correcto funcionamiento de esta máquina, y ésta usando ropa apropiada y autorizada. Cualquier modificación a la máquina anula la garantía y puede causar daños a las personas usando la máquina mientras esta en el funcionamiento.

REVISE EL PAQUETE A SU LLEGADA

Tras la recepcion de un envio Omcan favor inspeccionar daños externos. Si no hay daños evidentes en el empaque exterior, Habra el carton para asegurarse que todos los articulos solicitados estén dentro de la caja y no encuentre daños ocultos en la máquina. Si el paquete ha sufrido un manejo de poco cuidado, golpes o daños (visible o oculto) por favor anote en la factura antes de aceptar la entrega y contacte Omcan dentro de las 24 horas, de modo que podamos iniciar una reclamación con la compañía. Un informe detallado sobre los daños causados a la máquina debe ser llenado en el plazo de tres días, desde la fecha de entrega que se muestra en los documentos de envío. Omcan no tiene ningun recurso por productos dañados que se enviaron a recoger por terceros.

Antes de utilizar cualquier equipo, siempre lea y familiarizarse con todas las instrucciones de funcionamiento y seguridad.

Omcan le gustaría darle las gracias por la compra de esta máquina. Es de la mayor importancia para salvar estas instrucciones para futuras consultas. Además, guarda la caja original y el embalaje para el envío del equipo si servicio técnico o devolución de la máquina que se requiere.

Safety and Warranty

- Read all warning labels applied to any part of the machine, and promptly replace them when they become worn or illegible.
- Only trained and authorised personnel should operate the machine.
- If any part jams or locks up, before clearing make sure you first switch off the motor. DO NOT clean, oil or grease by hand any moving parts of the machine. In addition, all repair and setting operations of any moving parts with the motor running, are prohibited, unless the necessary precautions to prevent any accidents have been taken beforehand.

Safety and Warranty

- All moving parts are fitted with adequate guards and protections. Always remount them after removal for servicing.

WEAR ADEQUATE CLOTHING

Be sure to wear tight-fitting clothing without any loose parts. Never wear open or unfastened jackets, shirts or overalls.

IMPORTANT

To prevent accidents and ensure best performance the machine must not be modified or altered unless authorised by the manufacturer. Nor must it be used in conditions or for purposes other than those for which it has been expressly designed. Any arbitrary modification implemented in this machine will automatically exempt the manufacturer from any liabilities for ensuing damage or injury. This machine has been designed and engineered in conformity to European directives 89/392 EC, 91/368 EC, 93/44 EC and 93/68 EC.

ELECTRICAL SHOCK

For your own personal safety, before connecting the machine to mains:

- Check that power mains leading to distribution socket is fitted with an appropriate multipolar switch protected against overloads and shortcircuits.
- Carry out all phase connections, as well as any neutral and ground connections (compulsory) with a standard plug compatible with the above mentioned socket. The protection lead (ground) is the one with the yellow/green insulating sheath; make sure that the power supply cable is appropriate to its use, according to length, mains voltage and machine consumption.
- Unless adequate protections against electrical shock are fitted, do not operate the machine in damp or wet environments.

Strictly do not start up the machine without the protective panelling. This may jeopardise personnel safety and machine serviceability.

1 YEAR PARTS AND LABOUR WARRANTY

Within the warranty period, contact Omcan Inc. at 1-800-465-0234 to schedule an Omcan authorized service technician to repair the equipment locally.

Unauthorized maintenance will void the warranty. Warranty covers electrical and part failures, not improper use.

Please see www.omcan.com/warranty.html for complete info.

WARNING:

The packaging components are classified as normal solid urban waste and can therefore be disposed of without difficulty.

In any case, for suitable recycling, we suggest disposing of the products separately (differentiated waste) according to the current norms.

Safety and Warranty

DO NOT DISCARD ANY PACKAGING MATERIALS IN THE ENVIRONMENT!

Technical Specifications

Model	PM-IT-0080
Tank Capacity	110 lbs. / 50 kgs.
Power for Worm	5.5 HP / 4.1 kW
Power for Paddle	2.5 HP / 1.86 kW
Output per Hour	176 lbs. / 80 kgs.
Electrical	208V / 60Hz / 3
Weight	948 lbs. / 430 kgs.
Dimensions	53.1" x 33" x 63" / 1350 x 840 x 1600mm
Item Number	13286

Installation

TRANSPORTATION AND HANDLING

The machine, pallet-mounted at origin, is shipped enclosed in appropriate packaging and strapped to the wooden pallet itself. Apart from the machine, you can find the operating instructions and the conformity declaration to the EC 89/392 directive. The accessories furnished and the cutting groups must be put inside the packing case, suitably wrapped and protected. When unloading the machine from the transport vehicle, lift at the points marked on the packaging using suitable equipment. Unless you need to check the contents, you are recommended not to open the packaging until the moment of installation. After opening the case, remove packaging, straps, packaging and polystyrene strips. Dispose of this material according to the regulations in force. Lift the machine and place on the installation site and take-away the support pallet, using a hoist of appropriate capacity.

The lifting and positioning of the machine must be carried out by at least two people.

To position the machine definitively or when moving it for cleaning insert the tip of the lever in its proper hole (Fig.18) fully equipped with wheels; thereafter, pull the lever downwards in order to lift the machine to a forward position (Fig.19). At this point the machine is ready to be moved and can easily be put in its final position. Make sure that the manoeuvring board is horizontal and compact. To move the machine, lean on it in order to push it, while remembering always to keep the lever pressed downwards and make sure that there are no obstacles or impediments along the way that may prevent the normal rotation of the wheels. At the end, carefully release the lifting lever and check that the machine is firmly established on its four foot-supports.

INSTALLATION, CONNECTION AND SET-UP

Install and use the machine in a room that can be efficiently ventilated, and where the floor is smooth and compact and easy to clean.

WARNING: While the machine is operating, in order to obtain a product with the right thickness and humidity, avoid air currents which will cause precocious drying of the product together with its deterioration.

To assure machine stability, make sure that the wheels and feet are well positioned on the floor. Otherwise, thicken the front feet, by helping yourself with the lifting lever.

WARNING: This thickening operation must be carried out by at least two people.

Position the machine in the desired place with a free back space of around 50 centimeters and a side space of 70-80 centimeters in order to guarantee easy use of the machine and its cleaning (Fig.20). When continuous loading is foreseen, provide space for the mixer, elevator or manual loading as well. Check that the voltage of the machine which is written on the identification label matches the one foreseen by the system on your premises. Attach the right plug to the machine power cable in order to make the electrical connection to the system.

WARNING: Have the plug fitted to the power supply by qualified personnel. Take the necessary precautions to prevent the cable from being crimped or damaged.

INSTALLING THE CUTTING GROUPS

Both cutting groups must be installed. Unscrew the handwheel (Fig.21 A) with the plastic-moulded washer (Fig.21 B), set up the group and block it with the handwheel, positioning the washer correctly. Insert the feeding plug (Fig.22 A and B) to the group in the right machine outlet, note that the feeding tension are various and it is, therefore, not necessary to modify the plugs (Fig.22).

CONNECTION TO THE WATER SYSTEM



The machine comes equipped with a cooling system of the extrusion sleeve; to connect the machine to the water system (Fig.23) install the sending tube (Fig.23 B), (when it is non-existent: use a tap, possibly with screw-control) to the outer part of the machine, in order to regulate the water flow. The exit-flow tube (Fig.23 A) must allow free water discharge. We recommend that the water pressure inside the machine, does not exceed the 1.0 - 1.5 bar. To connect the external parts, use a flexible tube with an inside diameter of 13 mm, safely fixed by a metal band with a screw that can be closed with a screw-driver or key (Fig.24). After inserting the plug into the electrical socket the machine is ready to be used, after checking that all the elements of the machine are operating correctly.

Installation

CONTROL OF THE INSTALLATION

NOTE: Every drive is voluntarily run by the start button

Turn the general switch to position “1” (Fig.25 A) and check the following:

- Make sure that the mixer is rotating counter-clockwise, facing the front of the machine, when the switch (Fig.26) is placed on the “mix” position , (the Archimedean screw also turns counter-clockwise) (Fig.26 A). In the “0” position all of the machine’s elements should be still; in the drawplate position , the mixer turns clockwise, the Archimedean screw should turn the same way (check from the cover slits).
- Check the efficiency of the double safety device on the cover. The device sets off two micro-switches; one is controlled by the lever on the cover (Fig.28 A), inside the bar hole; and the other from the cover itself (Fig.28 B). To verify, check that the internal micro-switch starts to intervene only when the rod has not yet left the bar itself; you should hear the cover-microswitch click when the cover is loosened 10-15 mm.
- For functioning of push-buttons and flashing lights.
- The knife in its working position should be turning clockwise (Fig.27).
- The correct connection of the water cooling system, should include checking for eventual water leaks (Fig.24).

If the machine or some of its parts breakdown, call your local authorised dealer or concessionaire for repairs.

Operation

Only after making sure that the machine is completely clean, especially all the parts which are directly in contact with the product (extrusion sleeve, Archimedean screw, pool, mixer, drawplate, knife, guards, control system; if it is necessary, use some warm water; see CLEANING) you can carry out the requested operations in order to have the desired dough.

After having turned the machine off:

- Position the main switch on “0” (Fig.1 A) and check the correct set-up of the Archimedean screw, making sure that the cylinder part is sustained by the dragging shaft.
- Then make sure that the plastic cap (Fig.2 A) which replaces the drawplate is correctly positioned and the ring nut (Fig.2 B) is well-screwed on.
- Finally block the mixer in its place, thanks to the head-knob (Fig.2 C).

Lift the pool cover or hopper (Fig.3 B), by pulling the hooking lever (Fig.3 A), and always put in the pre-established ingredients in the following sequence: flour and then, after closing the cap, all the other liquid elements. In order to obtain the right dough, you need to create the precise ratio between the weight of the flour and the weight of the liquid part; in order to obtain a very good product, the flour has to contain a humidity percentage of no more than 15%; this allows the addition of water equal to 33% or up to 35% of the flour’s weight.

If you are using flours with different humidity contents, please change the quantity of the liquid in the opposite

ratio. Moreover, in order to better use the machine, the product inside the pool has to be higher than at a minimum level which coincides more or less with the position of the mixer axle.

USEFUL ADVICE IN ORDER TO OBTAIN A GOOD DOUGH

Any kind of flour can be used (bran or bran flour). The dough can be kneaded only with eggs or with a mix of water and eggs. Water can be partially replaced by spinach or well cut vegetables in order to obtain green noodles. Because the flour's humidity changes according to the kind used, the environment and the place where it is stocked, the quantities indicated have to be adapted to the kind of flour which is used, lowering or increasing the quantity of water. The dough is the right one when, at the end of kneading process, it is as big as coffee beans. If the lumps form in the flour you have poured in too much liquid. In this case, before turning the switch FROM KNEADING (Fig.4 A) TO DRAWING (Fig.4 B) you will have to add some more flour and knead a little longer. If the flour does not form a ball and is too floury, add some more water. For the dough for the sheet of pasta which is to be re-kneaded, use "00" flour and add two eggs per kilo of flour (maximum). With these quantities you will obtain a very stretchy dough which is easy to knead.

QUANTITIES IN ORDER TO OBTAIN A GOOD DOUGH

- Supposed weight of an egg: 50 grams.
- If you take 1 egg away you need to add 50 grams of water.
- To obtain a good dough: 1 kg of flour + 350 grams of humidity-liquid.

Close the cover or the hopper, position the general switch to "1" (Fig.5 A) and put the selector on position  (Fig.6 A). Push the start button (Fig.6 B). Add the liquid part pouring it gradually but as quickly as possible through the small hole in the cover. At the end of the kneading operation, which should take around 10 minutes, make sure the product has the right thickness and should look like coffee beans (check through the small holes of the cover). Turn the machine off by switching the selector to "0" (Fig.6 A).

INSTALLATION OF THE DRAWPLATE AND START-UP OF PRODUCTION

Make sure the machine is switched off.

Withdraw the drawplate and the filter requested from the container filled with water where it was put after its last use. Thoroughly rinse with plenty of running, warm water, in order to have the piece at the right temperature (see CLEANING). Dry it with a soft cloth. Unscrew the blocking ring nuts (Fig.7 A) and carefully clean the internal part including the edging. Take the plastic cap off (Fig.7 B). Set up the filter and the hopper while taking good care of the Archimedean screw frame at the center of the filter disk and drawplate (Fig.9 A and B). Close the metal ring with the help of the wrench supplied (Fig.8 A) and check that all the pieces are in the right places and not axially moved (see correct setting up procedure of the Archimedean screw). In order to start production, position the selector on the position  (Fig.6 A) and push the start button (Fig.6 B). The initial product coming out of the machine has an unacceptable appearance; this is the reason why it has to be eliminated. After a short time (a couple of minutes) the product coming out is acceptable, the colour goes from whitish to yellow and it has a greater consistency.

In order to cut the pasta to the desired length it is necessary to set up the cutting device, made up of motor and knife, chosen from those available.

Operation

CUTTING GROUP

The cutting group is chosen on the basis of the length of the pasta to be cut.

LONG-TYPE PASTA

Use group 1 with knife with alternative movement. Release the fixed handwheel (Fig.10 A) and wheel the group (Fig.10 B) until reaching the edge of the guide slit, the knife (Fig.10 C) must be at about the same height as the drawplate axle). Block the handwheel in the new position.

NOTE: Make sure that group 2 (Fig.10 D) which controls the rotating knife is in the stop position.

WARNING: The group position is signalled by a safety microswitch which prevents the functioning of the knife, if the group is not inserted in its correct functioning position.

Position the selector (Fig.11 A) on position 1 and regulate the potentiometer (Fig.11 B) to the number desired, bearing in mind that the numbers indicate the interval shown in seconds x 2, which pass between one cut and another.

SHORT-TYPE PASTA

Use group 2 (Fig.12 A) with rotating knife. Make sure that the control group 1 (Fig.12 B) is not in the functioning position, in order to avoid interference between the two groups. Prepare the group, by simply mounting the knife (Fig.12 C) on the control shaft (the knife must not be blocked in the shaft) while it is in the stop position. Position the cutting group (Fig.12 A) after having released the handwheel (Fig.13 A) in front of the drawplate (Fig.12 D), paying attention that the knife (Fig.12 C) moves axially towards the motor and adheres well to the drawplate (Fig.12 D). To complete this operation, facilitate the movement of the knife by helping yourself, with your hands, closing the knife tang between two fingers (Fig.12).

NOTE: This group is also controlled by a micro-switch that does not allow the knife to function in a different position from the one illustrated above.

NOTE: Remember to position the cutting group protection correctly.

Block the handwheel (Fig.13 A) and the selector on position 2 (Fig.11 A) and regulate the knife speed according to the desired pasta length, by turning the speed-control knob (Fig.11 D). The speed increases steadily from 0 to maximum, the numbers go from 0 to 10. If the product is quite wet and tends to be sticky, it is best to dry the surface in any case, by switching on the fan (Fig.14 A).

COOLING SYSTEM OF THE EXTRUSION SLEEVE

The machine is equipped with a cooling device of the extrusion sleeve that can be on, while bearing in mind some functioning parameters: Mixture consistency and room temperature. Open the regulating tap before beginning this operation.

NOTE: If the product is kneaded at an excessive temperature, it tends to change colour and/or blanch slightly.

Operation

The system functions automatically and maintains the same temperature shown on the extrusion sleeve.

FUNCTIONING OF THE DISPLAY CONTROL (FIG.15 C) AND TEMPERATURE SETTING

When the machine is turned on, the display button flashes for a few seconds and, therefore, shows the momentary temperature on the extrusion sleeve. To see the last temperature selected, press button "SET" (Fig.15 A) once. If you want to vary the sleeve control temperature, press the button "SET" and at the same time button "UP" or "DOWN" (Fig.15 B) depending on whether you want to increase or decrease the controlled temperature, until you see the desired temperature appear on the display unit. Release the pressed button, the system memorizes the new temperature, even if the machine is turned off. After a few seconds, the temperature shown on the sleeve will appear on the display unit. The feeler, positioned on the inside of the extrusion sleeve shows the temperature taken continuously and while comparing its value with the one defined, controls the opening and closing of the electrovalve which checks the water for cooling.

At the end of this operation:

- Stop the machine by positioning the pushbutton to start KNEADING/DRAWING and the other control buttons on the "0" position.
- Rotate the cutting group to the stop position (Fig.8).
- Put the selector on the mixture position for 10-15 seconds in order to eliminate the pressure on the drawplate caused by the product.
- Return the switch to "0".
- Turn off the machine pressing the general switch (Fig.1 A).
- Disassemble and wash the movable parts and clean the machine (see CLEANING).
- Turn off the water tap.

Maintenance

CLEANING

Warning: For healthy and hygienic processing of food products, be sure to keep your machine and the surrounding environment clean.

DANGER: Always cut off the power supply before cleaning.

You have to properly clean all the elements which are in contact with the product (Fig.29) protection cover, pool, mixer, Archimedean screw, drawplate, filter, ring nut and knife, when the product is still soft.

The moving parts have to be disassembled as follows:

- Mixer: make sure the external shovel is in the upper vertical position (Fig.29 A) (only this position allows the disassembling of the piece). Disassemble the mixer by unscrewing the external movable support until releasing the mixer; unthread the shaft from its place and at the same time, rotate the external pin towards the top. If you want to assemble the piece follow these instructions vice versa. Line the central point of the shaft with the peg of the moving support (Fig.34 A); thereafter, screw the support, but without blocking it.

Maintenance

- Metal ring, drawplate and filter: unscrew the metal ring with the appropriate wrench (Fig.30 A) being careful not to let any pieces fall, since the metal ring is moved from its place, the product and parts still weigh a few kilos and can easily slip from your hands, causing damage both to people or to the pieces themselves.
- Archimedean screw: after disassembling the ring nut, the drawplate and the filter, the Archimedean screw can easily be taken off the machine by pushing its spiral from the internal end.

COVER AND POOL CLEANING

Eliminate the dough residue and be sure to thoroughly clean the most remote-access pieces: connections of the Archimedean screw (Fig.31 B) and mixer (Fig.31 A) movements, extrusion sleeve, pool internal parts and cover grid. Use some warm water in order to eliminate the residual product and then rinse; dry the surfaces with the help of blotting paper and disinfectant, with a soft cloth dipped in odourless disinfectant.

WARNING: Never use non-nutritional, abrasive or corrosive chemicals to clean. Also never use coarse or abrasive objects such as steel wool, abrasive sponges and so on.

To clean the internal and external parts of the machine:

- Remove power supply plug from power mains socket.
- Clean coated surfaces with soft cloth and disinfect with alcohol.
- For the inside parts of the machine, take off the bigger back panel (Fig.33 A) and carry out the cleaning of the machine, bearing in mind the grease and dust, that are sometimes present; when finished, replace panel.

CLEANING OF MIXER, ARCHIMEDEAN SCREW, METAL RING, FILTER, DRAWPLATE AND KNIVES

WARNING: The alternative knife must not be taken apart: remove product left overs with a soft brush.

Eliminate the dough residue and wash the pieces with water; you may use a soft brush or a plastic pallet knife. These elements can be thoroughly washed in a dishwasher. Rinse and dry the mixer, the Archimedean screw, the metal ring and the knife and reassemble them on the machine. The drawplate and filter must be kept in a container placed in water for the entire period in which they are not being used. For reasons of hygiene, please change the water every day.

WARNING: Clean the surface below the machine daily, if necessary, temporarily move the machine from its usual working position.

MAINTENANCE AND ADJUSTMENT

WARNING: Remember that all maintenance operations are dangerous if you do not first disconnect the power supply plug from the power mains.

The machine parts requiring maintenance are the following: the Archimedean screw reducer, the upright push-bearing support, the movable mixer support, the sliding chains and belts. Disassemble the bigger back panel (Fig.33 A) upright.

Maintenance

MIXER SUPPORT (FIG.34)

Use registered fats for foods (USDA-H1) (in case of requirement contact your local dealer); perform maintenance daily.

PUSH-BEARING SUPPORT (FIG.35 A) AND CHAIN (FIG.36 A)

Use mineral grease type SAE MR3; maintenance needs to be carried out every six months. When controlling, grease the chains with as much oil as required.

REDUCER FOR EXTRUSION SHAFT (FIG.37)

Change oil after the first 500 - 1000 functioning hours, letting the carter oil drain out completely from the cap (Fig.37 A), afterwards, change the oil every 2000 working hours. To check level, see transparent cap positioned on the left-hand side of the pan (Fig.37 B). Pour the oil through the oil filler cap (Fig.37 C).

BELT STRETCHING

When performing the above mentioned maintenance or when the machine is not working properly, (loss of rounds) check the correct stretching of the transmission belt (Fig.36 B). For this reason, disassemble the left-hand side panel (Fig.36 C) from the machine and make sure that the belt is tight enough. If necessary, use the regulating system, by moving the motor and therefore, putting tension on the belt, without of course exaggerating. When finished, reset the panel.

Never use the machine with any missing, disassembled or open guards and shields.

If servicing operations require repairs to the electrical system and/or replacement of bearings or mechanical components, call an expert technician or your local dealer.

Troubleshooting

Problem	Cause	Solution
Machine operation Failure	Disconnected plug.	Connect plug.
	Plug leads not correctly connected.	Check lead connections.
	Trip switch adjusted for insufficient values.	Adjust trip switch accordingly.
	Unsuitable trip switch.	Replace trip switch.
	Fuses burnt out.	Replace fuse.
	Safety rod on pool cover not properly inserted	Position rod at end of stroke.
The product gets stuck when being poured out.	Too humid dough is used.	Reduce the quantity of water used for the dough respecting the abovementioned percentage.

Troubleshooting

The product looks unacceptable even after the initial minutes: it breaks and loses flour.	Too short kneading time.	Increase the kneading time.
	Not enough water percentage.	Increase the quantity of water in order to respect the aforementioned percentage.
The product does not come out of the drawplate.	The blocking of the drawplate because of dried dough.	Disassemble and clean the drawplate.
The product crushed at an edge during cutting.	Cutting speed not adequate (too low).	Increase cutting speed: remember that the length of the pasta cut, depends on the pasta and drawplate diameter.

Figure Drawings

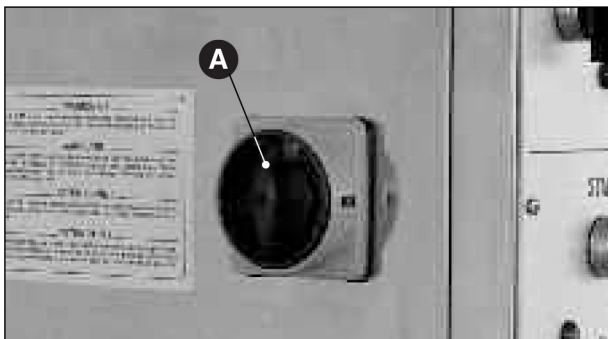

Fig. 1

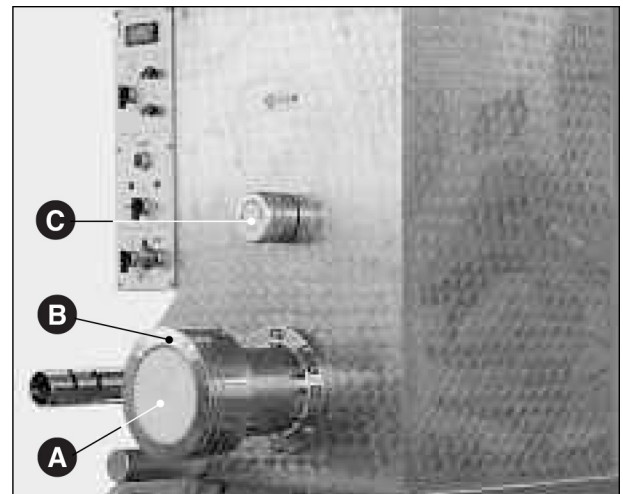

Fig. 2

Figure Drawings

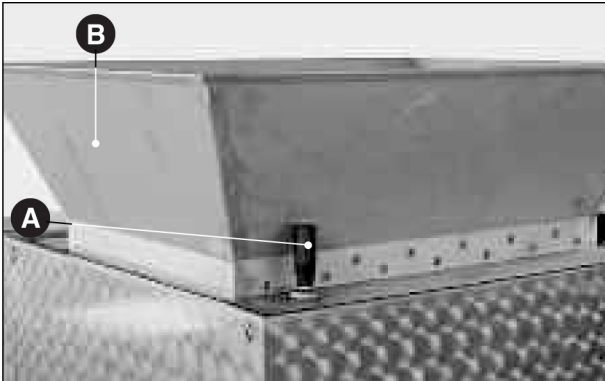

Fig. 3

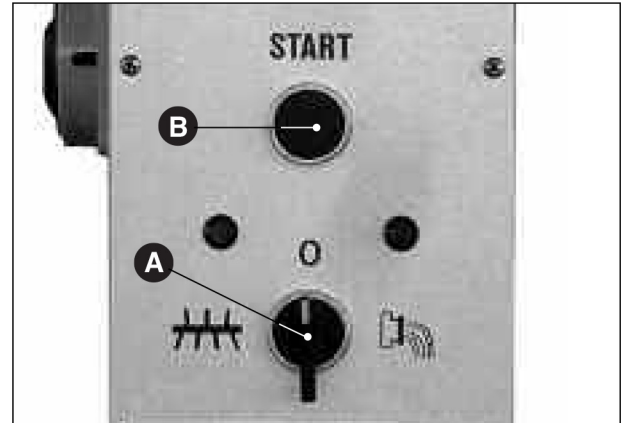

Fig. 6

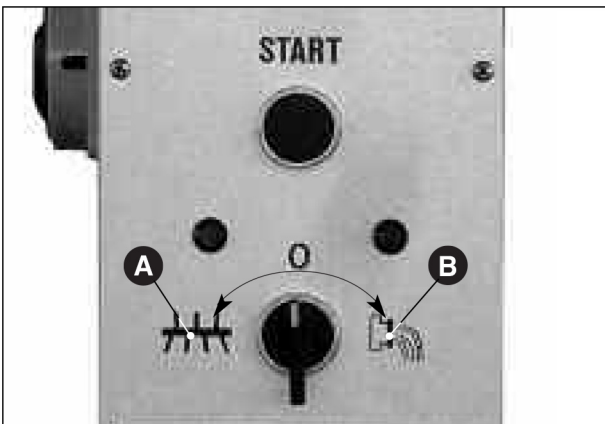

Fig. 4

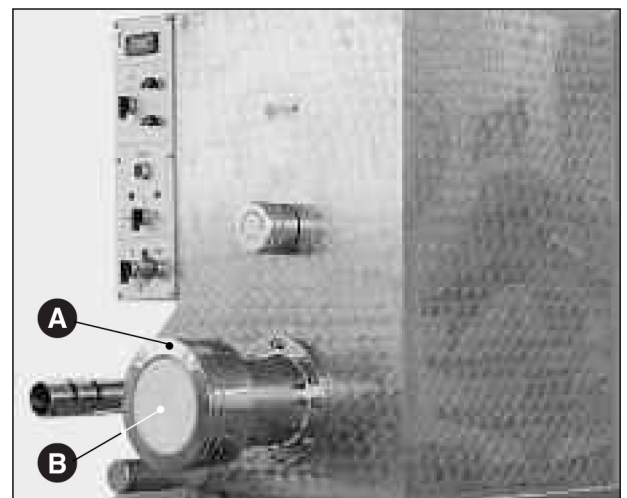

Fig. 7



Fig. 5

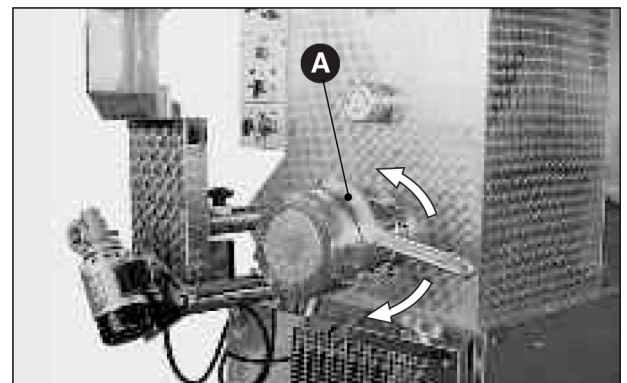

Fig. 8

Figure Drawings

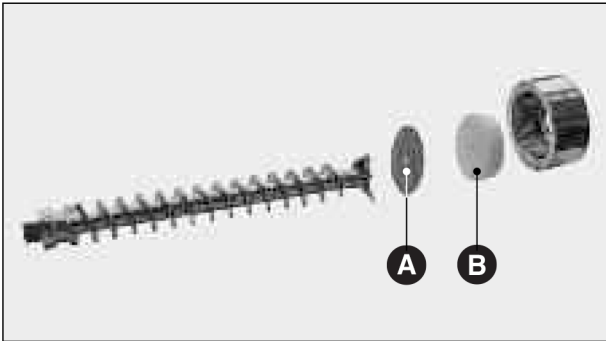

Fig. 9

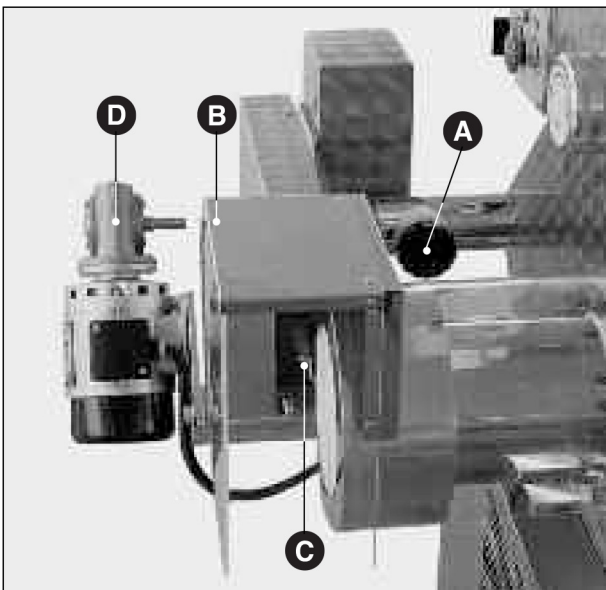

Fig. 10

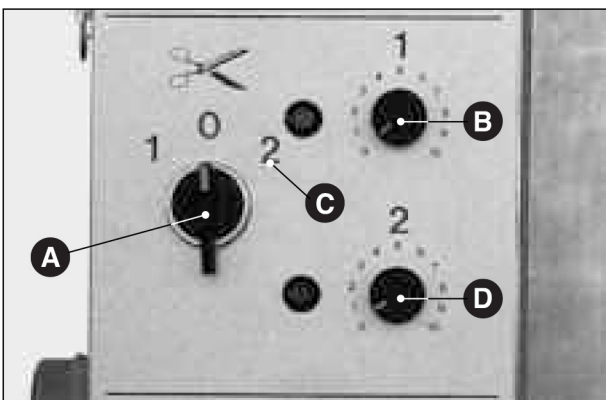

Fig. 11

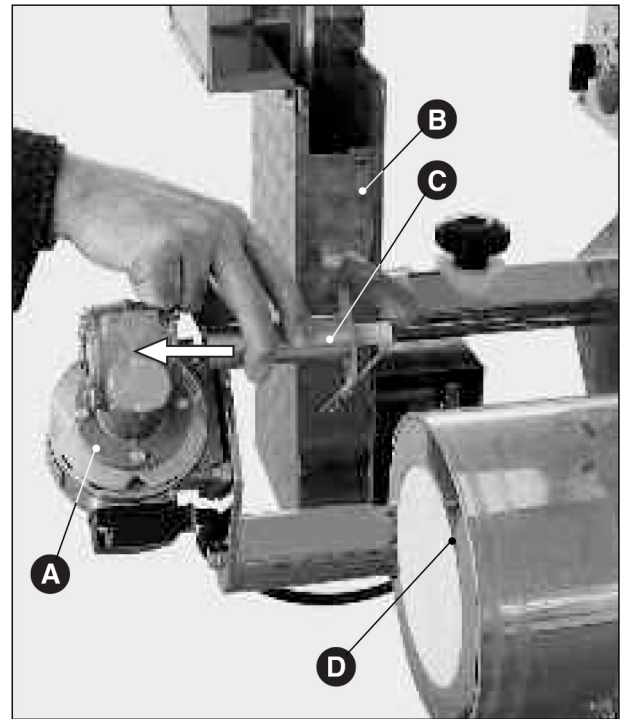

Fig. 12

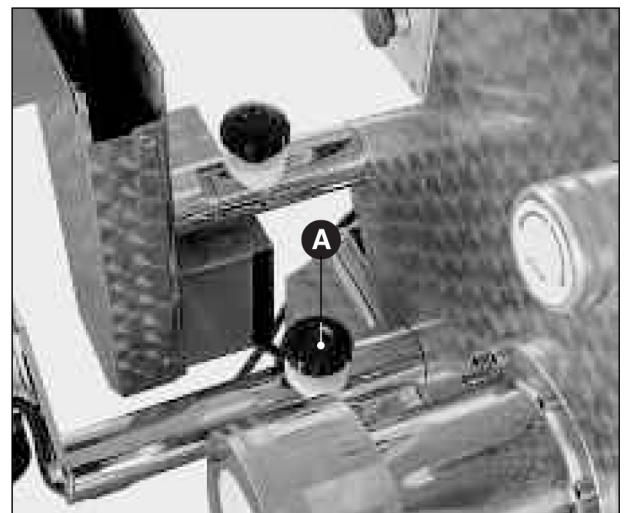

Fig. 13

Figure Drawings

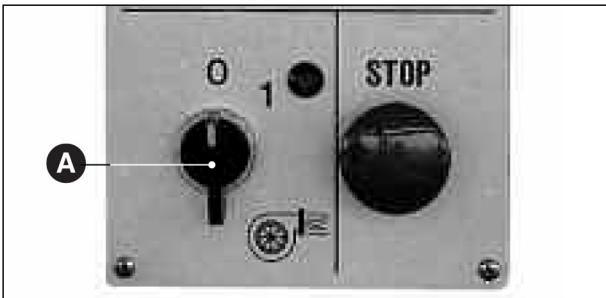

Fig. 14

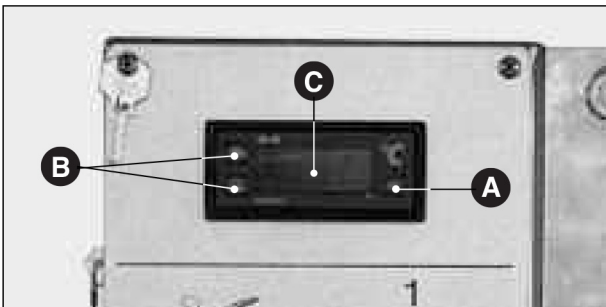

Fig. 15



Fig. 18



Fig. 17

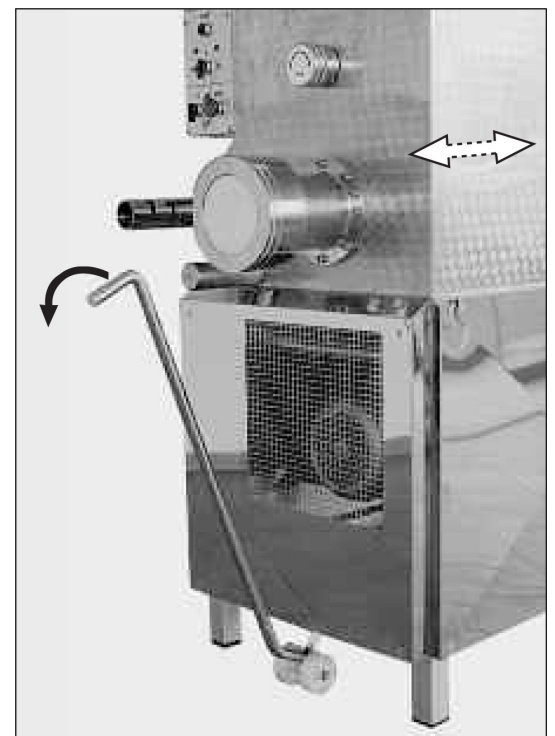

Fig. 19

Figure Drawings

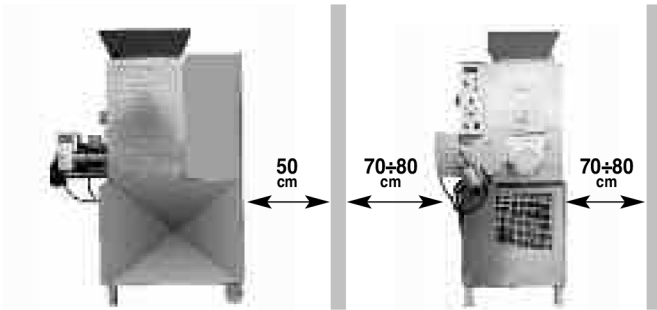

Fig. 20

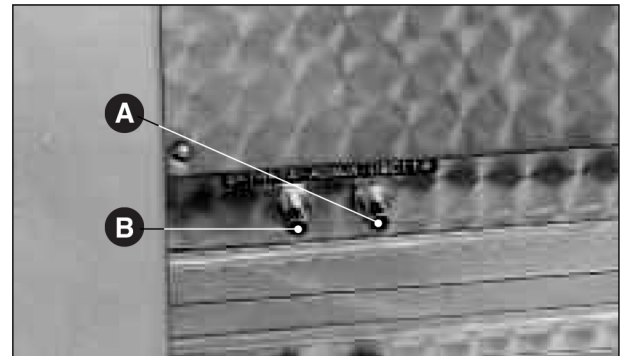

Fig. 23

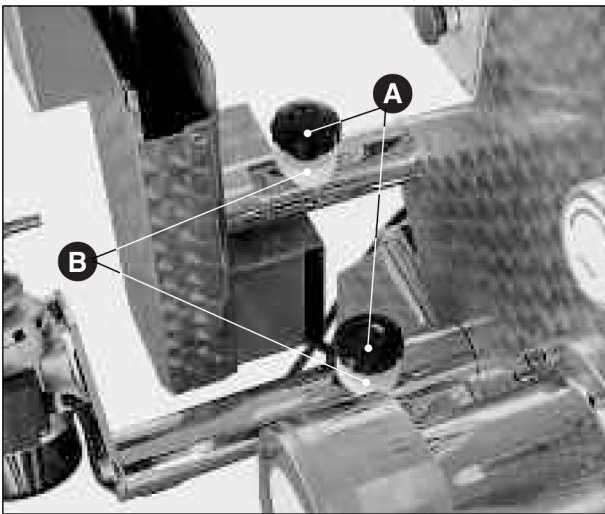

Fig. 21



Fig. 24

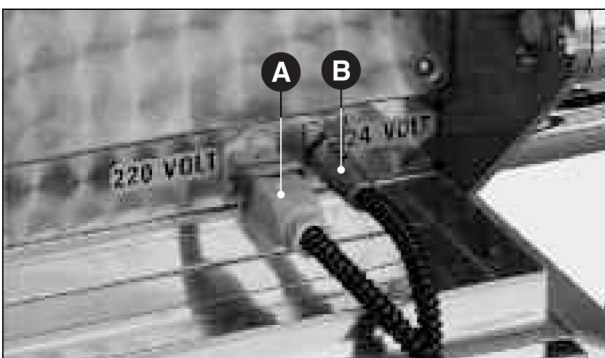

Fig. 22



Fig. 25

Figure Drawings

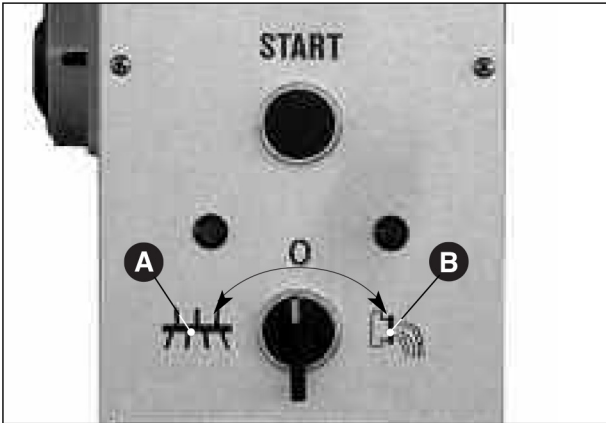

Fig. 26

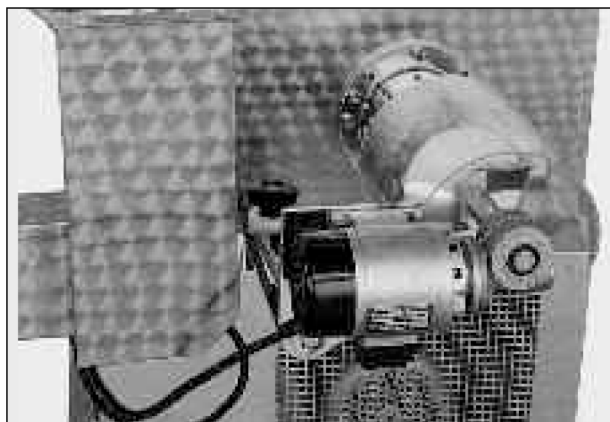

Fig. 27

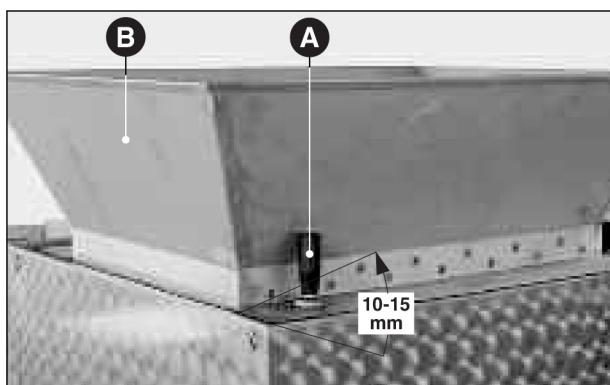

Fig. 28

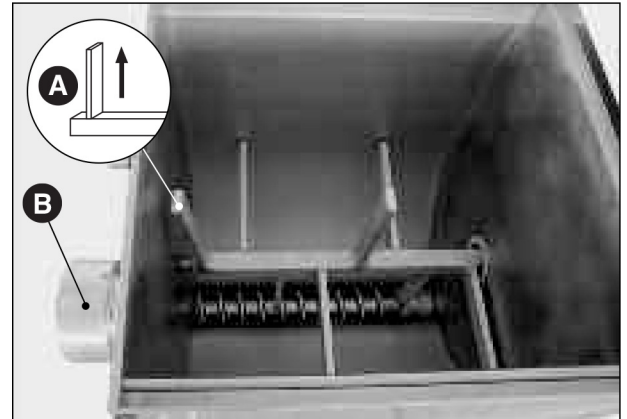

Fig. 29

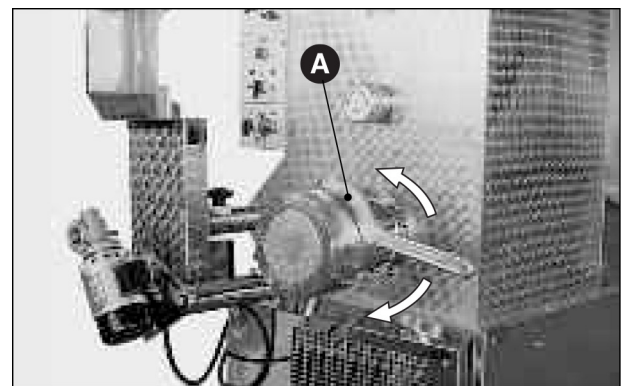

Fig. 30

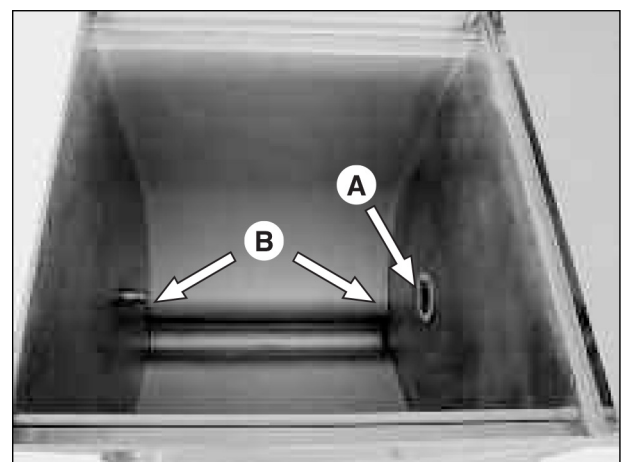

Fig. 31

Figure Drawings

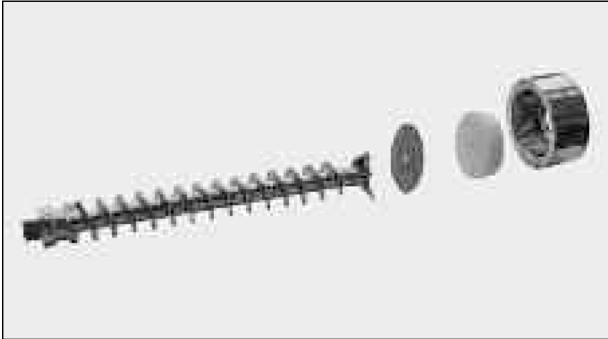

Fig. 32

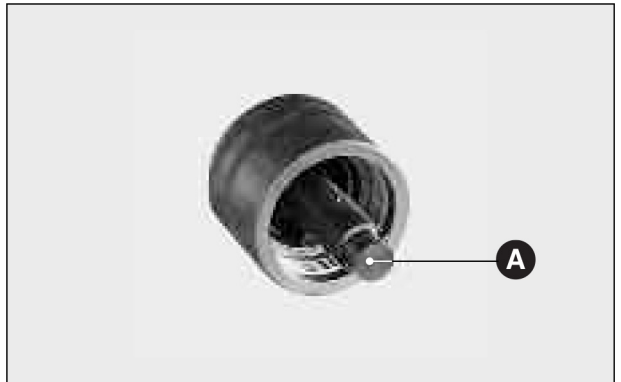

Fig. 34

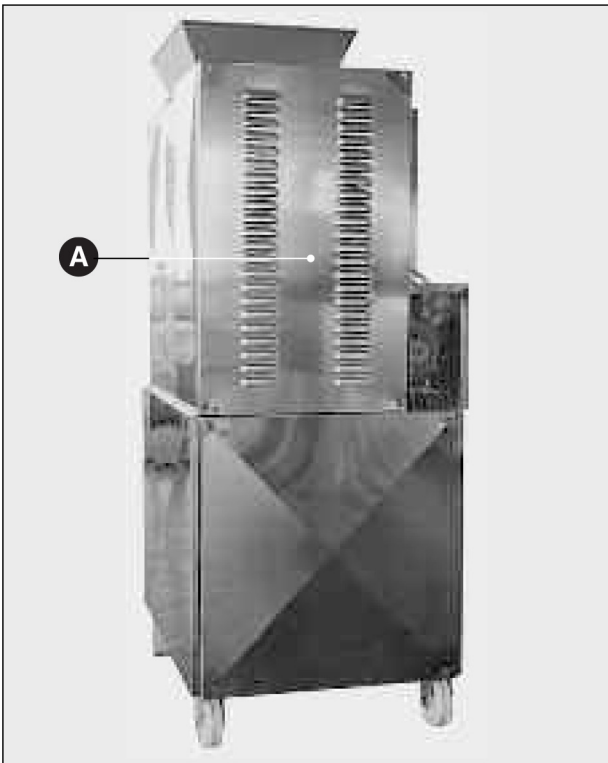

Fig. 33

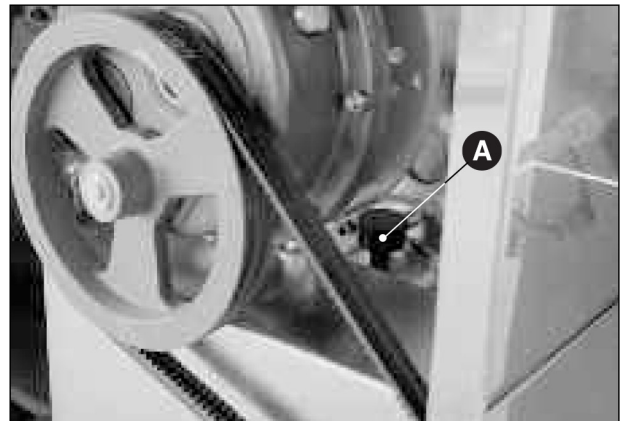

Fig. 35

Figure Drawings

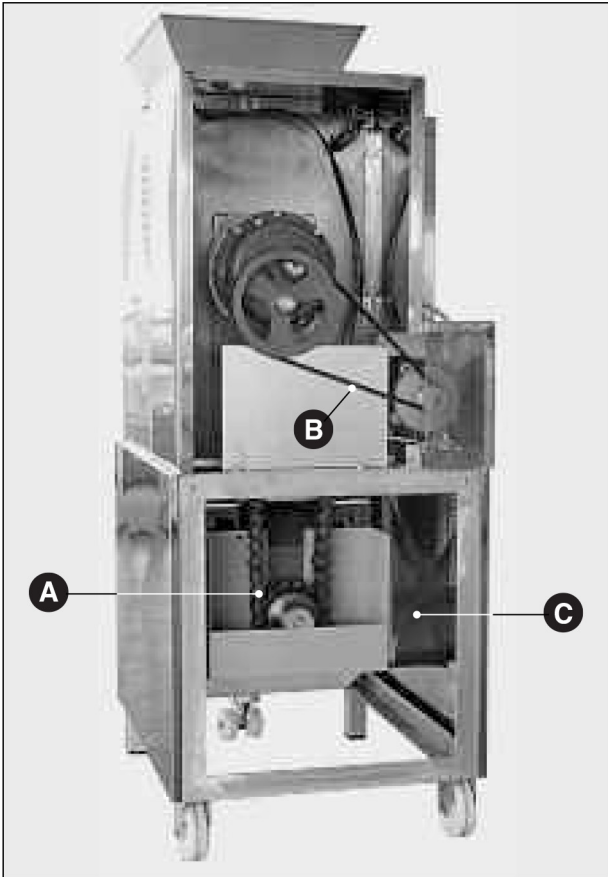

Fig. 36

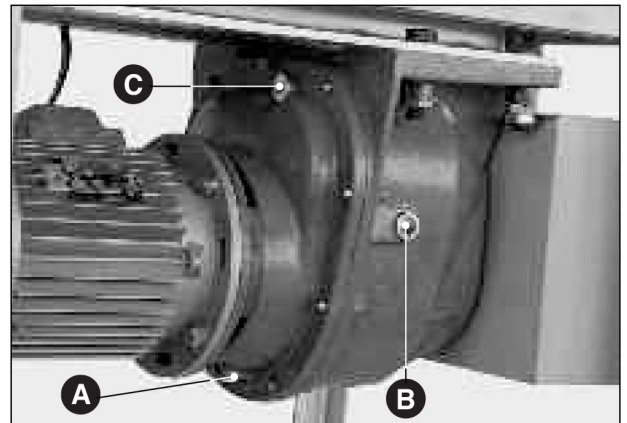
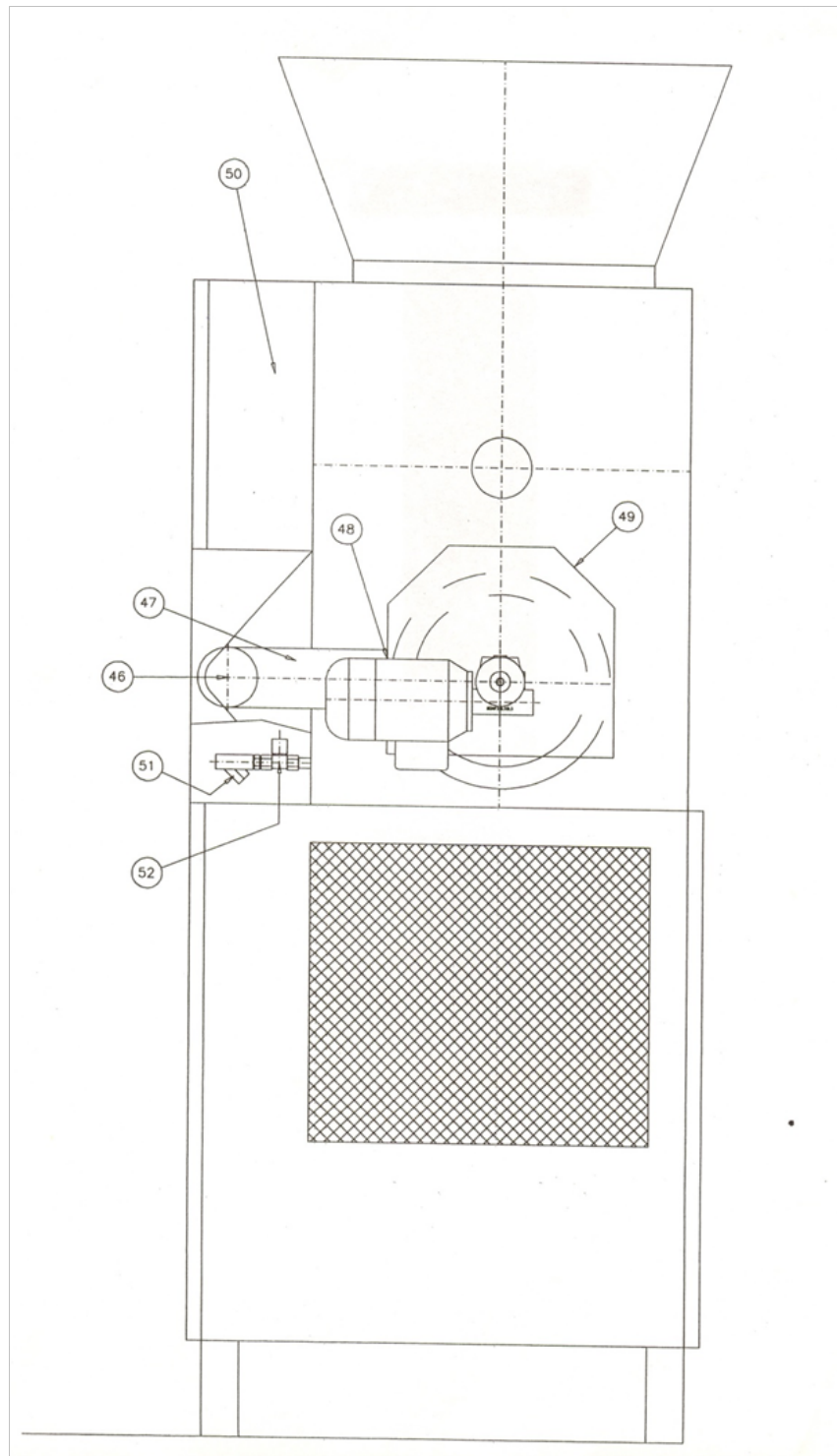

Fig. 37

Parts Breakdown

Model PM-IT-0080 13286



Parts Breakdown

Model **PM-IT-0080** 13286

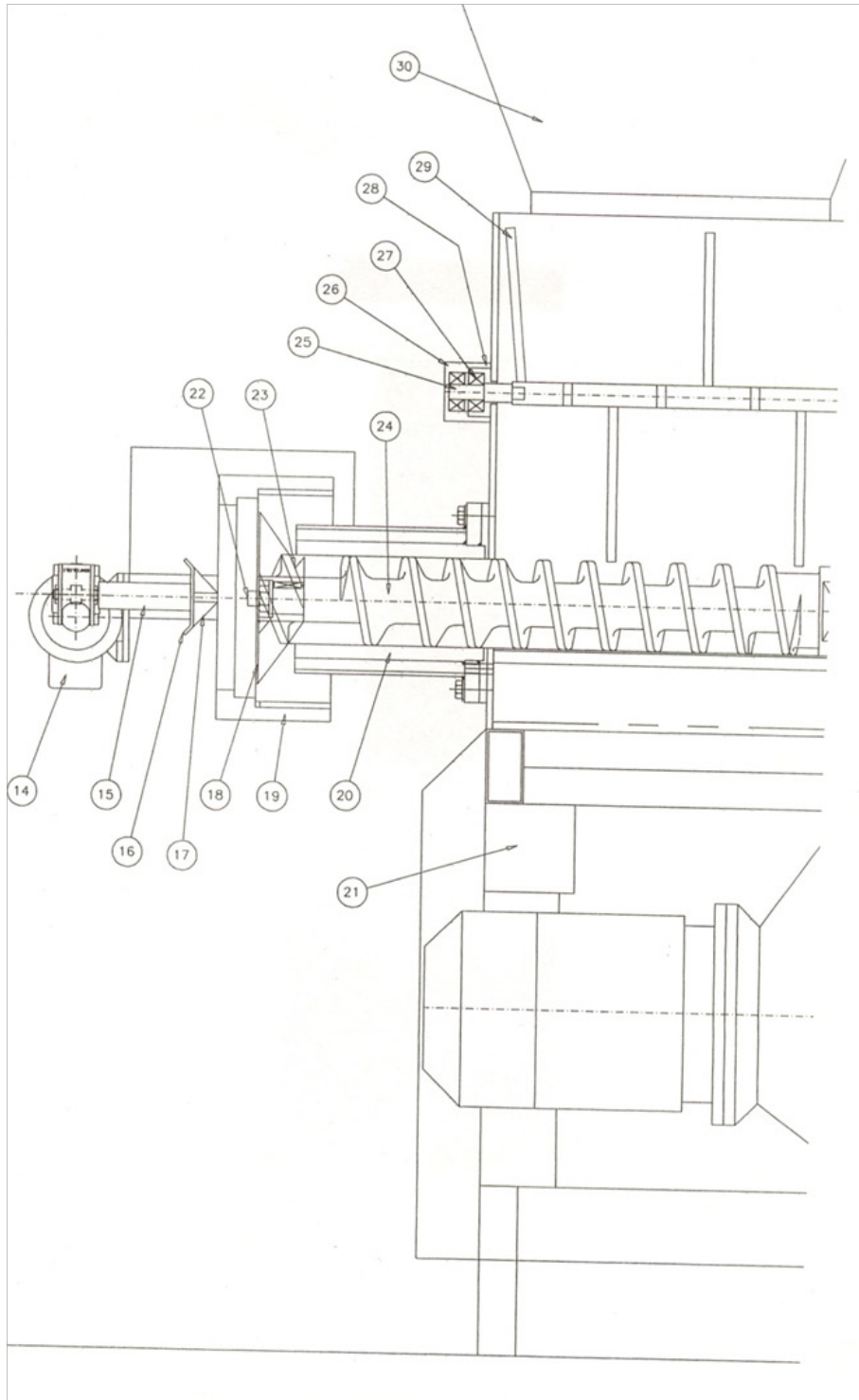

Parts Breakdown

Model PM-IT-0080 13286

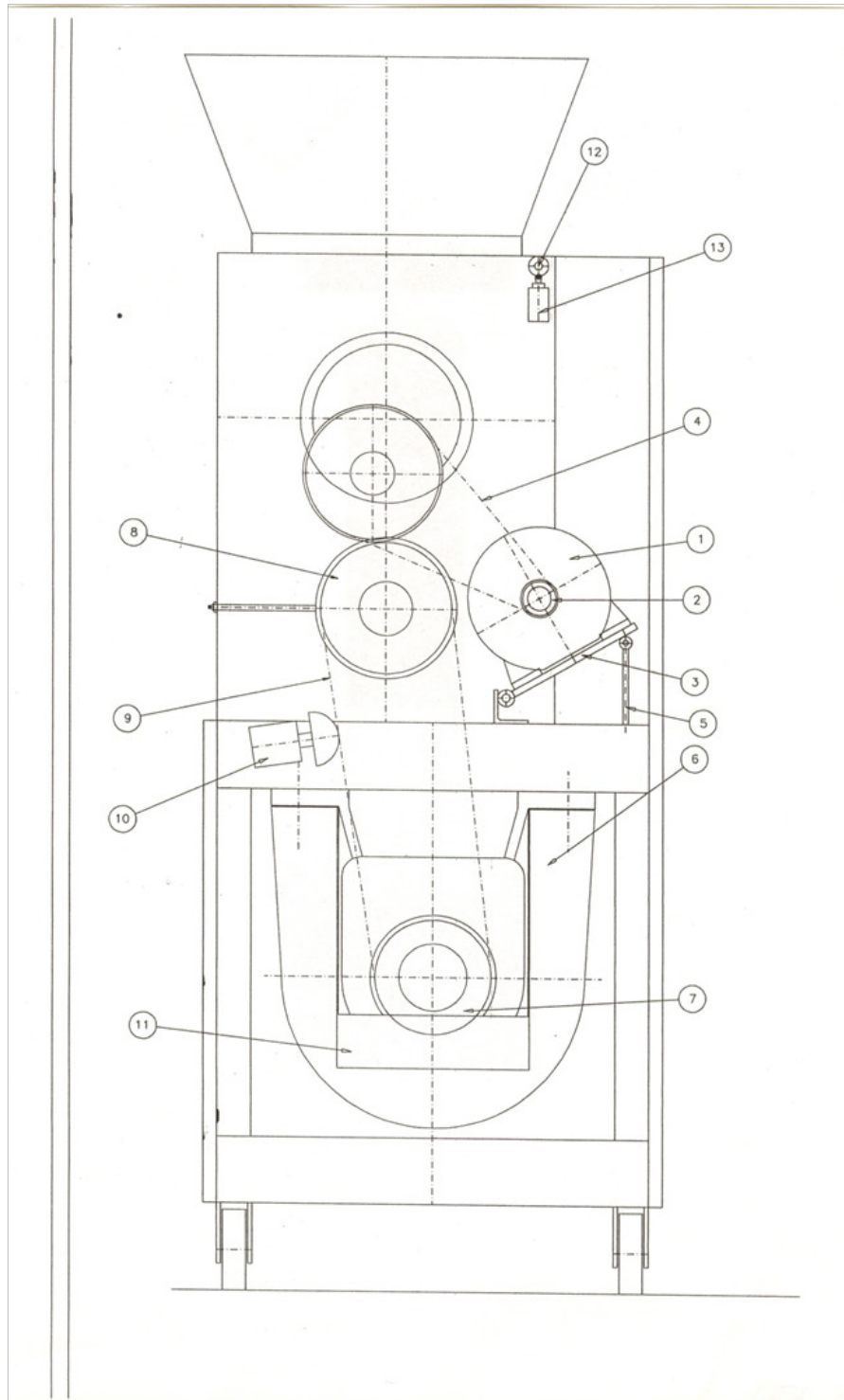

Parts Breakdown

Model PM-IT-0080 13286

Item No.	Description	Position	Item No.	Description	Position	Item No.	Description	Position
62520	Mixer Motor for TR150	1	62538	Ring for TR150	19	62556	Distance for TR150	37
62521	Motor Pulley for TR150	2	62539	Cylinder for TR150	20	62557	Bearing for TR150	38
62522	Motor Support for TR150	3	62540	Fan for TR150	21	62558	Red Cover for TR150	39
62523	Belt for TR150	4	62541	Central Steering Wheel for TR150	22	62559	Pin for TR150	40
62524	Tightener for TR150	5	62542	Front Mixer for TR150	23	62560	Lower Support for TR150	41
62525	Motor Screw for TR150	6	62543	Compression Screw for TR150	24	62561	Sealing Ring for TR150	42
62526	Pinion for TR150	7	62544	Mobile Tree Mixer for TR150	25	62562	Distance for TR150	43
62527	Pinion Duct for TR150	8	62545	Mobile Mixer Support for TR150	26	62563	Distance for TR150	44
62528	Chain for TR150	9	62546	Bearing for TR150	27	62564	Wheel for TR150	45
62529	Idler Chain for TR150	10	62547	Fixed Mixer Support for TR150	28	62565	Fixed Motor Knife for TR150	46
62530	Oil Tank for TR150	11	62548	Mixer for TR150	29	62566	Mobile Support for TR150	47
62531	Cam for TR150	12	62549	Hopper for TR150	30	62567	Base Motor Knife for TR150	48
62532	Micro Switch for TR150	13	62550	Superior Support for TR150	31	62568	Knife Protection for TR150	49
62533	Cutting Motor for TR150	14	62551	Tree for TR150	32	62569	Electrical Frame for TR150	50
62534	Tri-Blade for TR150	15	62552	Bearing for TR150	33	62570	Filter for TR150	51
62535	Light Support for TR150	16	62553	Mixer Reducer for TR150	34	62571	Electric Valve for TR150	52
62536	Long for TR150	17	62554	Conducted Pulley for TR150	35			
62537	Filter for TR150	18	62555	Lower Tree for TR150	36			

Electrical Schematics

Model PM-IT-0080 13286

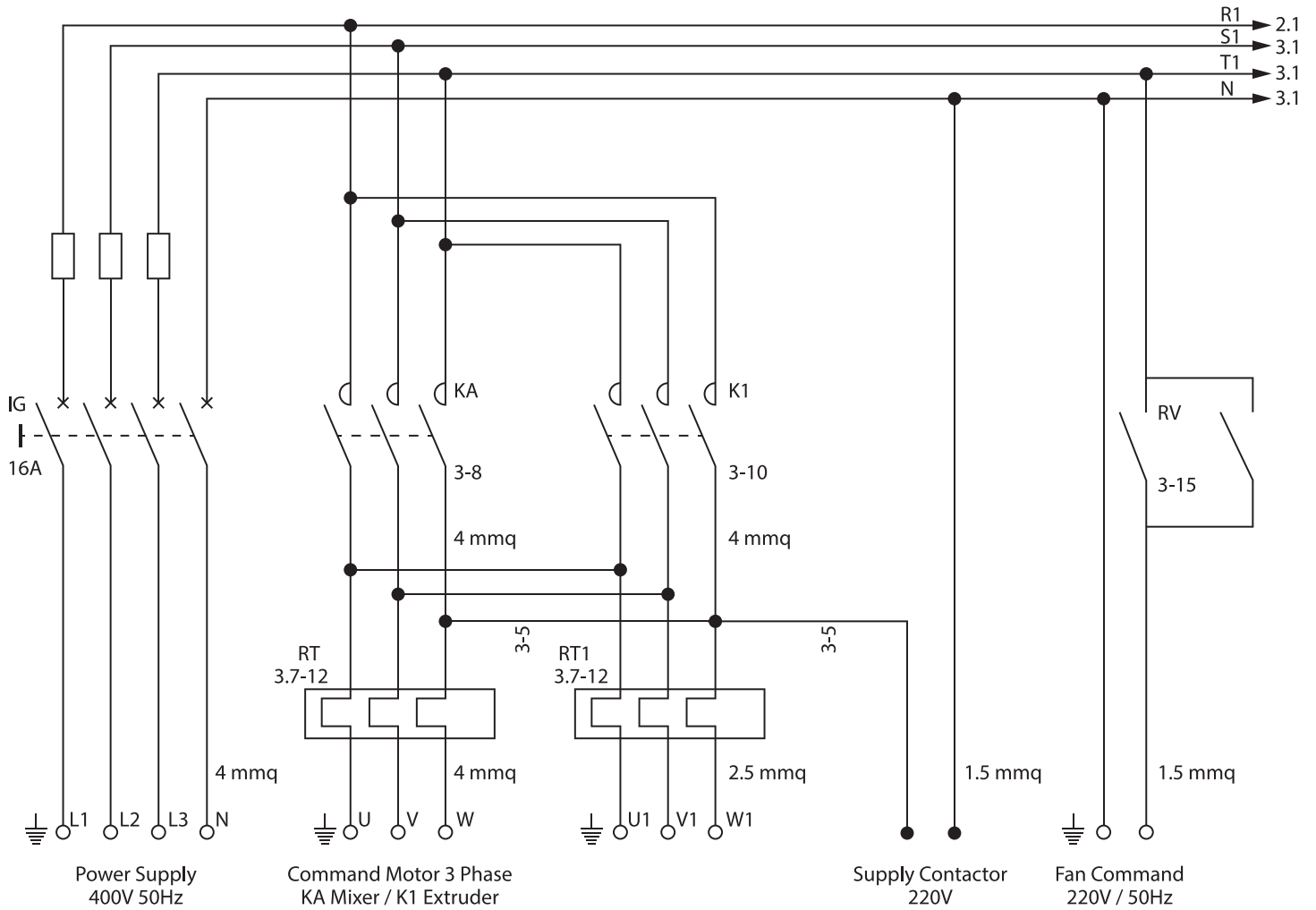

Electrical Schematics

Model PM-IT-0080 13286

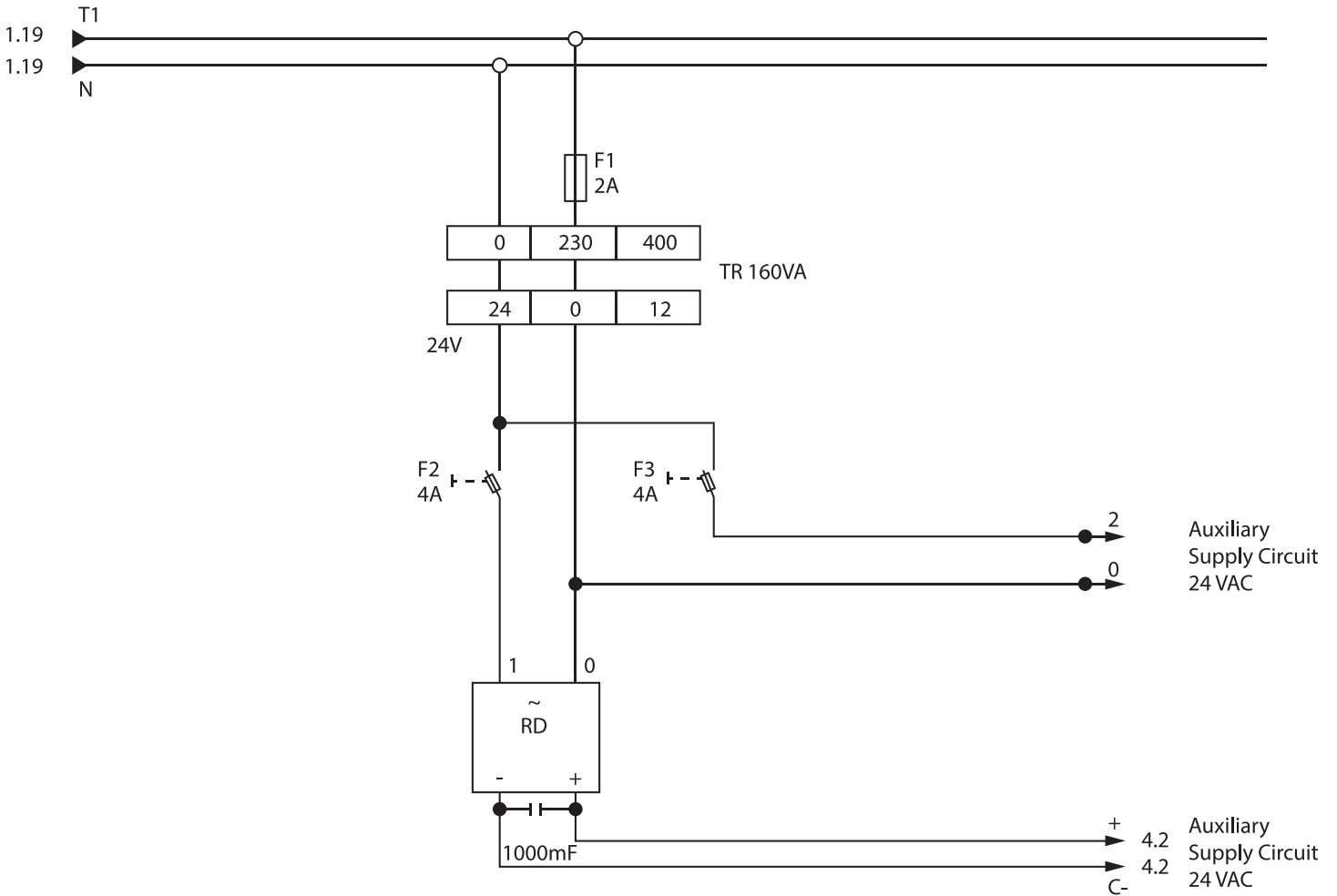

Electrical Schematics

Model PM-IT-0080 13286

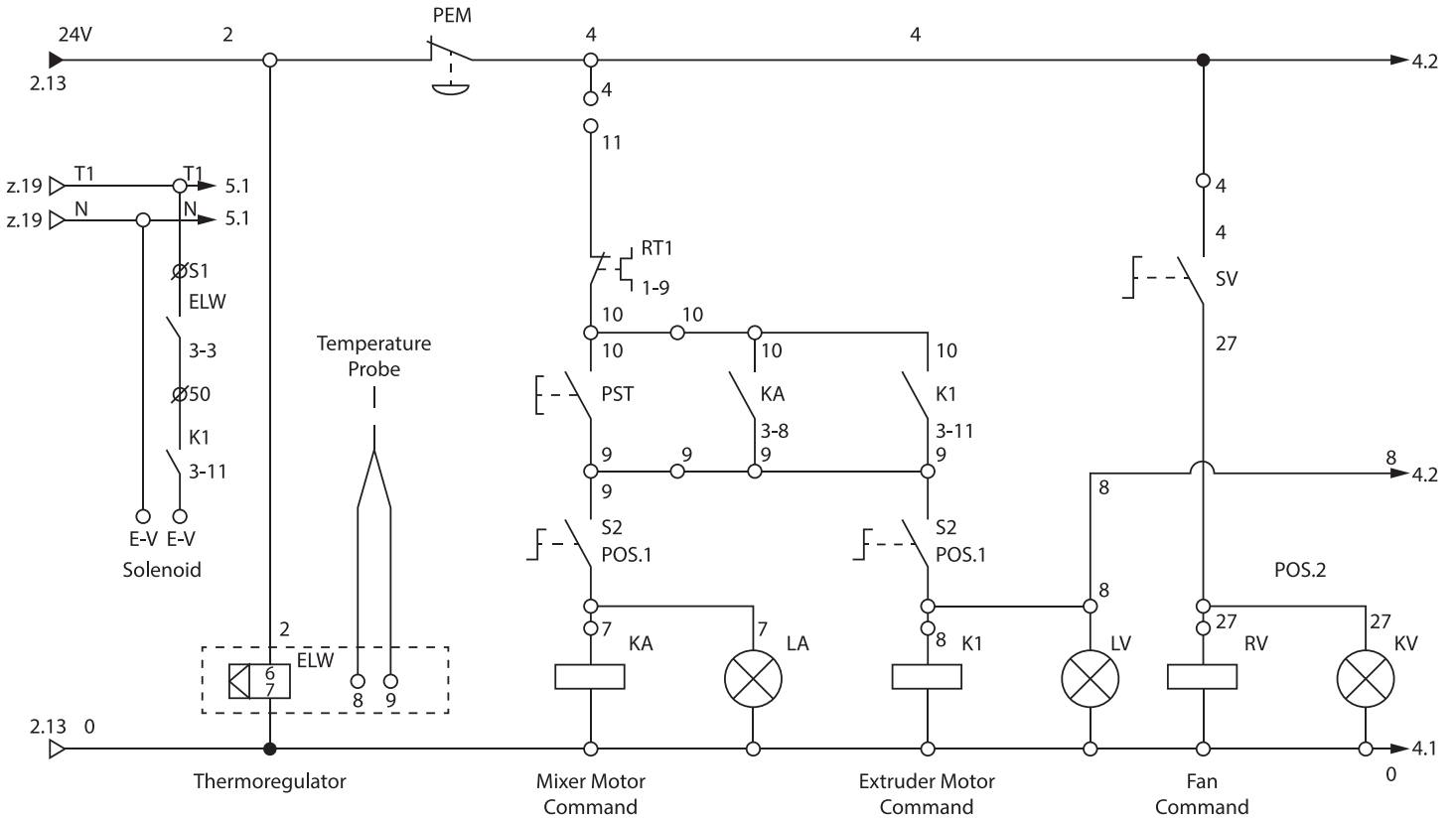

Electrical Schematics

Model PM-IT-0080 13286

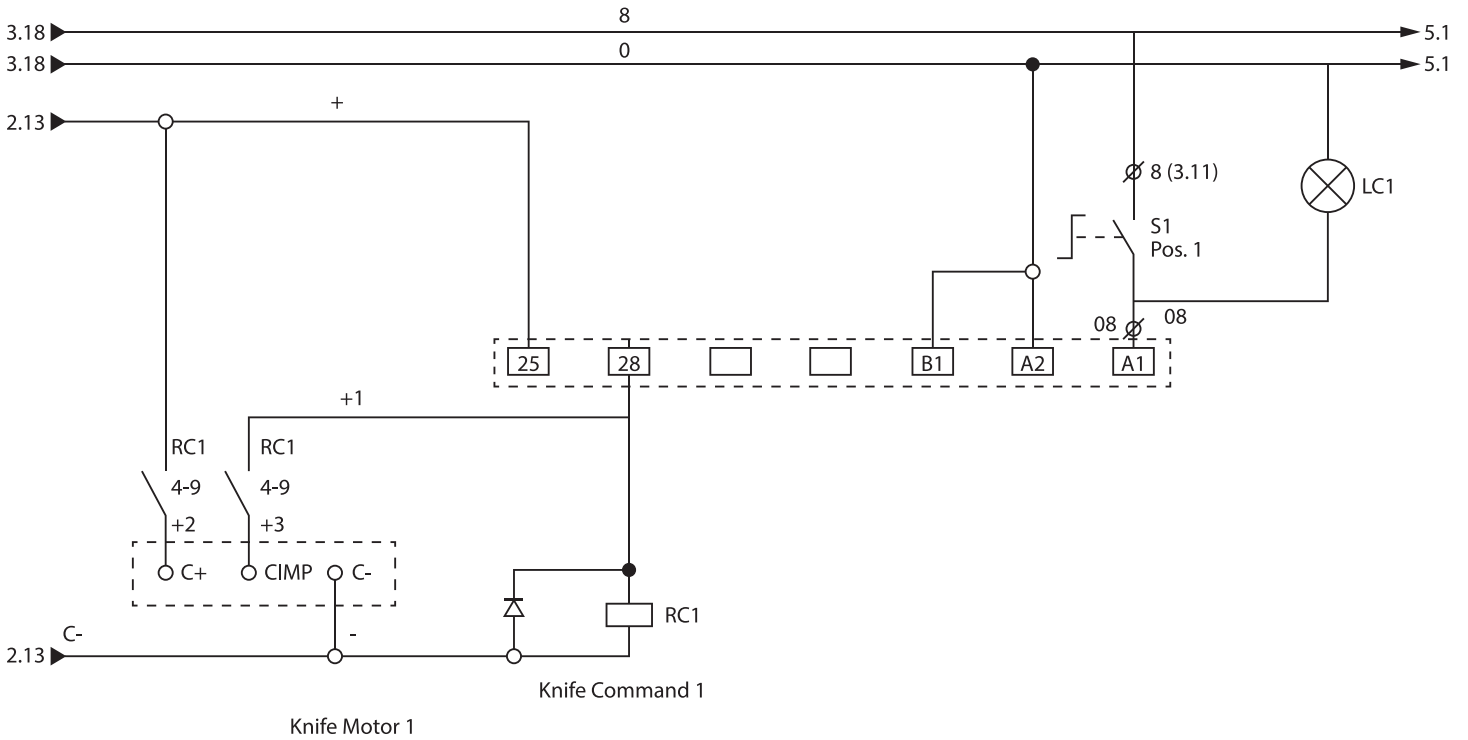

Electrical Schematics

Model PM-IT-0080 13286

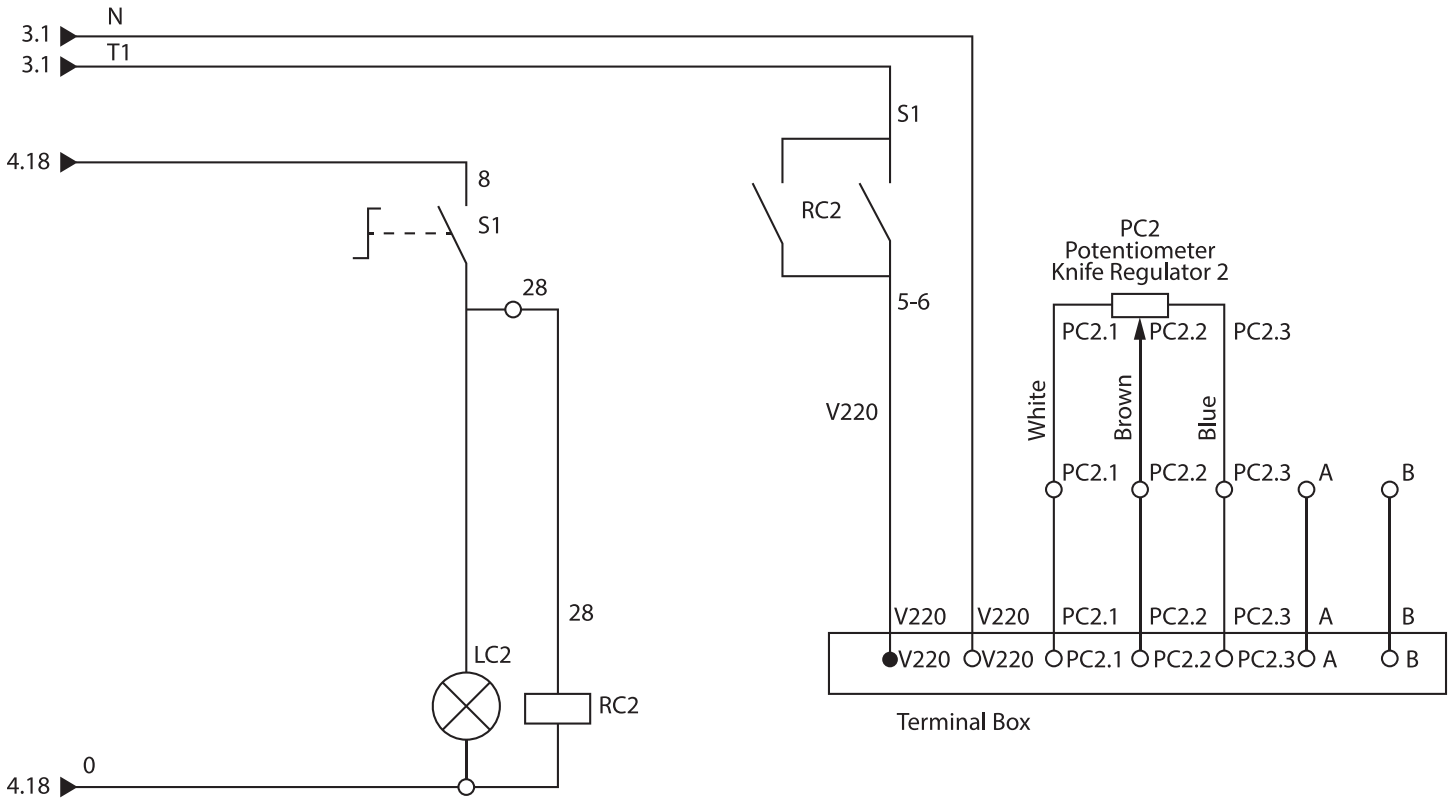



Warranty Registration

Thank you for purchasing an Omcan product. To register your warranty for this product, complete the information below, tear off the card at the perforation and then send to the address specified below. You can also register online by visiting:

Merci d'avoir acheté un produit Omcan. Pour enregistrer votre garantie pour ce produit, complétez les informations ci-dessous, détachez la carte au niveau de la perforation, puis l'envoyer à l'adresse spécifiée ci-dessous. Vous pouvez également vous inscrire en ligne en visitant:

Gracias por comprar un producto Omcan usted. Para registrar su garantía para este producto, complete la información a continuación, cortar la tarjeta en la perforación y luego enviarlo a la dirección indicada a continuación. También puede registrarse en línea en:

www.omcan.com/warrantyregistration.html

For mailing in Canada

Pour postale au Canada

Por correo en Canadá

OMCAN

PRODUCT WARRANTY REGISTRATION

3115 Pepper Mill Court,

Mississauga, Ontario

Canada, L5L 4X5

For mailing in the US

Pour diffusion aux États-Unis

Por correo en los EE.UU.

OMCAN

PRODUCT WARRANTY REGISTRATION

4450 Witmer Industrial Estates, Unit 4,

Niagara Falls, New York

USA, 14305

or email to: service@omcan.com



Purchaser's Information

Name: _____

Address: _____

City: _____ Province or State: _____ Postal or Zip: _____

Country: _____

Dealer from which Purchased: _____

Dealer City: _____ Dealer Province or State: _____

Invoice: _____

Model Name: _____ Model Number: _____

Machine Description: _____

Date of Purchase (MM/DD/YYYY): _____

Would you like to extend the warranty? Yes No

Company Name: _____

Telephone: _____

Email Address: _____

Type of Company:

Restaurant Bakery Deli

Butcher Supermarket Caterer

Institution (*specify*): _____

Other (*specify*): _____

Serial Number: _____

Date of Installation (MM/DD/YYYY): _____

Thank you for choosing Omcan | Merci d'avoir choisi Omcan | Gracias por elegir Omcan



Since 1951 Omcan has grown to become a leading distributor of equipment and supplies to the North American food service industry. Our success over these many years can be attributed to our commitment to strengthen and develop new and existing relationships with our valued customers and manufacturers. Today with partners in North America, Europe, Asia and South America, we continually work to improve and grow the company. We strive to offer customers exceptional value through our qualified local sales and service representatives who provide convenient access to over 3,500 globally sourced products.

Depuis 1951 Omcan a grandi pour devenir un des “leaders” de la distribution des équipements et matériel pour l’industrie des services alimentaires en Amérique du Nord. Notre succès au cours de ces nombreuses années peut être attribué à notre engagement à renforcer et à développer de nouvelles et existantes relations avec nos clients et les fabricants de valeur. Aujourd’hui avec des partenaires en Amérique du Nord, Europe, Asie et Amérique du Sud, nous travaillons continuellement à améliorer et développer l’entreprise. Nous nous efforçons d’offrir à nos clients une valeur exceptionnelle grâce à nos ventes locales qualifiées et des représentants de service qui offrent un accès facile à plus de 3500 produits provenant du monde entier.

Desde 1951 Omcan ha crecido hasta convertirse en un líder en la distribución de equipos y suministros de alimentos en América del Norte industria de servicios. Nuestro éxito en estos años se puede atribuir a nuestro compromiso de fortalecer y desarrollar nuevas relaciones existentes con nuestros valiosos clientes y fabricantes. Hoy con socios de América del Norte, Europa, Asia y América del Sur, que trabajan continuamente para mejorar y crecer la empresa. Nos esforzamos por ofrecer a nuestros clientes valor excepcional a través de nuestro local de ventas y representantes de los servicios que proporcionan un fácil acceso a más de 3,500 productos con origen a nivel mundial.

