



Pizza Ovens

Models PE-IT-0024-S, 0048-D, 0049-D, 0049-DD
Items 40637, 40638, 40641, 40643

Instruction Manual



Revised - 12/11/2019



Toll Free: 1-800-465-0234
Fax: 905-607-0234
Email: service@omcan.com
www.omcan.com



Table of Contents

Model PE-IT-0024-S / Model PE-IT-0048-D
Model PE-IT-0049-D / Model PE-IT-0049-DD

Section	Page
General Information -----	3 - 4
Safety and Warranty -----	4 - 6
Technical Specifications -----	6
Installation -----	6 - 7
Operation -----	8 - 14
Maintenance -----	15
Troubleshooting -----	16 - 17
Parts Breakdown -----	18 - 27
Electrical Schematics -----	28 - 31
Notes -----	32 - 34
Warranty Registration -----	35



General Information

Omcan Manufacturing and Distributing Company Inc., Food Machinery of America, Inc. dba Omcan and Omcan Inc. are not responsible for any harm or injury caused due to any person's improper or negligent use of this equipment. The product shall only be operated by someone over the age of 18, of sound mind, and not under the influence of any drugs or alcohol, who has been trained in the correct operation of this machine, and is wearing authorized, proper safety clothing. Any modification to the machine voids any warranty, and may cause harm to individuals using the machine or in the vicinity of the machine while in operation.

CHECK PACKAGE UPON ARRIVAL

Upon receipt of an Omcan shipment please inspect for external damage. If no damage is evident on the external packaging, open carton to ensure all ordered items are within the box, and there is no concealed damage to the machine. If the package has suffered rough handling, bumps or damage (visible or concealed), please note it on the bill of lading before accepting the delivery and contact Omcan within 24 hours, so we may initiate a claim with the carrier. A detailed report on the extent of the damage caused to the machine must be filled out within three days, from the delivery date shown in the shipping documents. Omcan has no recourse for damaged products that were shipped collect or third party.

Before operating any equipment, always read and familiarize yourself with all operation and safety instructions.

Omcan would like to thank you for purchasing this machine. It's of the utmost importance to save these instructions for future reference. Also save the original box and packaging for shipping the equipment if servicing or returning of the machine is required.

Omcan Fabrication et distribution Compañie Limité et Food Machinery d'Amérique, dba Omcan et Omcan Inc. ne sont pas responsables de tout dommage ou blessure causé du fait que toute personne ait utilisé cet équipement de façon irrégulière. Le produit ne doit être exploité que par quelqu'un de plus de 18 ans, saine d'esprit, et pas sous l'influence d'une drogue ou d'alcool, qui a été formé pour utiliser cette machine correctement, et est vêtu de vêtements de sécurité approprié. Toute modification de la machine annule toute garantie, et peut causer un préjudice à des personnes utilisant la machine ou des personnes à proximité de la machine pendant son fonctionnement.

VÉRIFIEZ LE COLIS DÈS RÉCEPTION

Dès réception d'une expédition d'Omcan veuillez inspecter pour dommages externes. Si aucun dommage n'est visible sur l'emballage externe, ouvrez le carton afin de s'assurer que tous les éléments commandés sont dans la boîte, et il n'y a aucun dommage dissimulé à la machine. Si le colis n'a subi aucune mauvaises manipulations, de bosses ou de dommages (visible ou cachée), notez-le sur le bond de livraison avant d'accepter la livraison et contactez Omcan dans les 24 heures qui suivent, pour que nous puissions engager une réclamation auprès du transporteur. Un rapport détaillé sur l'étendue des dommages causés à la machine doit être rempli dans un délai de trois jours, à compter de la date de livraison indiquée dans les documents d'expédition. Omcan n'a aucun droit de recours pour les produits endommagés qui ont été expédiés ou cueilli par un tiers transporteur.

General Information

Avant d'utiliser n'importe quel équipement, toujours lire et vous familiariser avec toutes les opérations et les consignes de sécurité.

Omcan voudrais vous remercier d'avoir choisi cette machine. Il est primordial de conserver ces instructions pour une référence ultérieure. Également conservez la boîte originale et l'emballage pour l'expédition de l'équipement si l'entretien ou le retour de la machine est nécessaire.

Omcan Empresa De Fabricacion Y Distribucion Inc. Y Maquinaria De Alimentos De America, Inc. dba Omcan y Omcan Inc. no son responsables de ningun daño o perjuicio causado por cualquier persona inadecuada o el uso descuidado de este equipo. El producto solo podra ser operado por una persona mayor de 18 años, en su sano juicio y no bajo alguna influencia de droga o alcohol, y que este ha sido entrenado en el correcto funcionamiento de esta máquina, y ésta usando ropa apropiada y autorizada. Cualquier modificación a la máquina anula la garantía y puede causar daños a las personas usando la máquina mientras esta en el funcionamiento.

REVISE EL PAQUETE A SU LLEGADA

Tras la recepcion de un envio Omcan favor inspeccionar daños externos. Si no hay daños evidentes en el empaque exterior, Habra el carton para asegurarse que todos los articulos solicitados estén dentro de la caja y no encuentre daños ocultos en la máquina. Si el paquete ha sufrido un manejo de poco cuidado, golpes o daños (visible o oculto) por favor anote en la factura antes de aceptar la entrega y contacte Omcan dentro de las 24 horas, de modo que podamos iniciar una reclamación con la compañía. Un informe detallado sobre los daños causados a la máquina debe ser llenado en el plazo de tres días, desde la fecha de entrega que se muestra en los documentos de envío. Omcan no tiene ningun recurso por productos dañados que se enviaron a recoger por terceros.

Antes de utilizar cualquier equipo, siempre lea y familiarizarse con todas las instrucciones de funcionamiento y seguridad.

Omcan le gustaría darle las gracias por la compra de esta máquina. Es de la mayor importancia para salvar estas instrucciones para futuras consultas. Además, guarda la caja original y el embalaje para el envío del equipo si servicio técnico o devolución de la máquina que se requiere.

Safety and Warranty

WARNINGS FOR THE INSTALLER

Check that the location of the oven is in compliance with local and national regulations.

- Adhere to the instructions in this manual.
- Do not execute electrical connections using temporary or uninsulated cables.
- Check that the ground connection of the electrical system is functioning properly.
- Always use individual safety devices and other means of protection in compliance with the law.

Safety and Warranty

WARNING FOR THE USER

The conditions in the surrounding area where the machine will be installed must have the following characteristics:

- The area must be dry.
- The area must have water and heat sources at an adequate distance.
- Ventilation and lighting must be suitable and comply with the hygiene and safety standards foreseen by current laws.
- The floor must be flat and compact to facilitate thorough cleaning.
- There must be no obstacles of any kind in the immediate vicinity of the machine that could effect the machine's normal ventilation.

In addition, the user must:

- Make certain to keep children away from the machine when it is operating.
- Adhere to the instructions in this manual.
- Not remove or tamper with the safety devices on the machine.
- Always pay careful attention to the work at hand and not use the machine when in a distracted state.
- Perform all operations with maximum safety and calm.
- Respect the instructions and warnings displayed on the machine labels.

The labels are accident prevention devices, and therefore must always be perfectly legible. If these should be damaged and illegible, it is mandatory to replace them by requesting replacements from the Manufacturer.

- At the end of each working shift, before cleaning, maintenance or transfer operations, disconnect electrical power.

WARNINGS FOR THE MAINTENANCE OPERATOR

Observe the instructions indicated in this manual.

- Always use individual safety devices and other protection means.
- Before starting any maintenance operations, make sure that the oven, it was used, is cooled down.
- If any of the safety devices is worn or faulty, the oven is also considered faulty and not to be used.
- Disconnect electrical power before intervening on electrical or electronic parts and connectors.

1 YEAR PARTS AND LABOUR WARRANTY

Within the warranty period, contact Omcan Inc. at 1-800-465-0234 to schedule an Omcan authorized service technician to repair the equipment locally.

Unauthorized maintenance will void the warranty. Warranty covers electrical and part failures, not improper use.

Please see <https://omcan.com/disclaimer> for complete info.

Safety and Warranty

WARNING:

The packaging components are classified as normal solid urban waste and can therefore be disposed of without difficulty.

In any case, for suitable recycling, we suggest disposing of the products separately (differentiated waste) according to the current norms.

DO NOT DISCARD ANY PACKAGING MATERIALS IN THE ENVIRONMENT!

Technical Specifications

Model	PE-IT-0024-S	PE-IT-0048-D	PE-IT-0049-D	PE-IT-0049-DD
Maximum Temperature	450° C / 842° F			
Electrical	220V / 60Hz / 3Ph			
Power	6600 W	13200 W	18000 W	
Pizza per Hour	80 - 14" pizzas	120 - 14" pizzas	200 - 14" pizzas	
Chamber Dimensions	27.6" x 27.6" x 5.9" 701 x 701 x 150mm	(27.6" x 27.6" x 5.9") x 2 (701 x 701 x 150mm) x 2	(41.3" x 27.6 x 5.9") x 2 (1049 x 701 x 150mm) x 2	
External Dimensions	43" x 39.8" x 16.9" 1092 x 1011 x 429mm	43" x 39.8" x 29.5" 1092 x 1011 x 749mm	56.9" x 39.8" x 29.5" 1445 x 1011 x 749mm	
Weight	253 lbs. / 114.8 kgs.	403.4 lbs. / 183 kgs.	509 lbs. / 230.9 kgs.	508.2 lbs. / 230.5 kgs.
Item Number	40637	40638	40641	40643

Installation

Installation must be executed by qualified personnel in compliance with local and national regulations.

OVEN POSITIONING

Ensure that the oven is put on a stand with the suitable carrying capacity and that is flat.

After unpacking the oven from its packing, position it in prepared location, taking into account the minimum distances.

Remove possible protections in polystyrene and take off the protecting film (F)

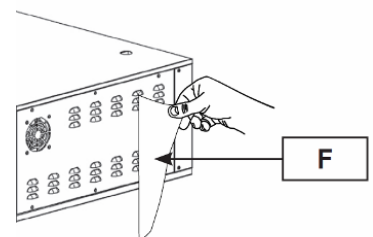

Installation

avoiding to use tools which can damage the surfaces.

EQUIPMENT HOOK-UP

Electrical connection

The oven is not provided with power supply cable. When connecting the appliance electrically, an automatic RCD must be interposed with an opening distance between contacts of at least 3 mm. To connect the appliance electrically it is essential to proceed in the following way:

- Remove the right side panel.
- Connect to the terminal block the power cable.

The power supply cable must be of H07-RNF type, with approved minimum cross section as prescribed by the specific directive.

The electrical outlet must be easy to access, no moving should be necessary.

The electrical connection (plug) must be easily accessible, also following oven installation.

The distance between the machine and the socket must be adequate to not cause tension in the power supply cable. In addition, the cable must not be located beneath the machine support base.

If the electrical power supply cable is damaged, it must be replaced by the technical assistance service or by a qualified technician to prevent any risks.

GROUND CONNECTION

It is mandatory that the electrical system is equipped with a ground connection.

The appliance must be part of an equipotential system. The connection is done on terminal marked with symbol which you will find near the cable clamp. The section of the equipotential wire must be at least 10mm². The equipotential symbol is showed in the following figure.



Operation

DIGITAL OVEN START UP AND USE

COMMAND PANEL DESCRIPTION



The digital control panel allows the separate setting of top heating's elements and bottom heating's elements, furnishing in real time the information on the temperatures. It also allows the activation and set point of the timer, and the delay of lighting.

FUNCTION OF THE KEYS

ON/OFF KEY

When the digital control panel is in position Off (switched off) one push enables the switch on of the same. When the digital control panel is "on", the continuous push for three seconds enables shifting into "Off" (switched off).

TOP KEY / P1 PROGRAM

When the digital control panel is active (and the display shows the average baking chamber temperature), pushing once the touch programme 1 is taken back and signal "P1" is shown. A minimum three seconds lasting push enables the modification of top temperature set (of the selected programme).

BOTTOM KEY / P2 PROGRAM

When the digital control panel is active (and the display shows the average baking chamber temperature), by

pushing once the touch Programme 2 is taken back and "P2" is shown. A minimum three seconds lasting push enables the modification of the bottom temperature (of the selected programme).

INCREMENT VALUE KEY / VISUALIZATION TOP TEMPERATURE

When the display shows the average baking chamber temperature, pushing once the touch top temperature is shown. When programme modalities (p1 or p2) or other modalities active, same touch enables the increase of the selected value.

DECREMENT VALUE KEY / VISUALIZATION BOTTOM TEMPERATURE

When the display shows the average baking chamber temperature, pushing once the touch bottom temperature is shown. When programme modalities (p1 or p2) or other modalities, same touch enables decrease of the selected value.

CLOCK KEY / DELAY TIME

When the digital control panel is active, three seconds continuous push enables to modify the switch on delay (clock signal blinks)

COOKING TIMER KEY

When the digital control panel is active, a three seconds continuous push enables to modify the baking time (timer signal blinks).

START/STOP KEY

When the digital control panel is active:







- After setting the delayed switch-on, the single push of start/stop touch enables the countdown of the delayed switch on.
- When the delayed switch on countdown is under process, a three seconds lasting push of the start/stop touch enables to disconnect the same.
- After setting the baking timer the single push of start/stop touch enables the baking timer countdown.
- When the baking timer countdown is under process a single push of start/stop enables to stop counting. A further single push enables to activate again the counting.
- When the baking timer countdown is working, the three seconds lasting start/stop push enables to deactivate the timer.

MEANING OF DISPLAY ICONS

°C CELSIUS ICON: It is active when the temperature is set in Celsius.

°F FAHRENHEIT ICON: It is active when the temperature is set in Fahrenheit.

Operation

-  **TOP TEMPERATURE ICON:** It is active when the top probe temperature is showed on the display. This icon flashes during the variation of the top temperature set point.
-  **BOTTOM TEMPERATURE ICON:** It is active when the bottom probe temperature is showed on the display. This icon flashes during the variation of the bottom temperature set-point.
-  **TIMER ICON:** It is active during the timer countdown. This icon flashes during the timer set-point.
-  **CLOCK ICON:** It is active during the delay time countdown. This icon flashes during the delay time set-point.
-  **TOP HEATING ELEMENTS ICON:** It is active when the top heating elements are turned on.
-  **BOTTOM HEATING ELEMENTS ICON:** It is active when the bottom heating elements are turned on.

FIRST LIGHTING OF THE OVEN

At the first use of the appliance it is advisable to heat the empty oven to eliminate bad smells caused by the refractory stones evaporation and the inner metallic parts.

Procedure:

- Fully open the exhauster valve.
- Set the main switch in the position “1” after checking that the oven is connected with the power supply.
- Heat up the heating elements by pushing the on/off switch on the digital control panel.
- Leave the oven working (empty) for at least 8 hours at the temperature of 300° C before proceeding to the first baking.

START UP PHASE

After connecting the oven to the electric net rotate the main switch in position “1”. The digital control panel light on and the word off is shown on the display. At this stage it is possible to start heating the oven by pushing the on/off touch, with the consequent the heating elements start-up (top and bottom) of the baking chamber. By pushing the on/off touch a short lamp-test takes place, after that for roughly 5 seconds the programme under process is shown (p1 or p2). At this stage the display shows the average baking chamber temperature and the thermostat setting takes place. This operation consists of the electronic and automatic use of the heating elements to reach and maintain the temperatures set in the used programme (p1 or p2).

FUNCTION OF DIGITAL CONTROL PANEL

The main functions of the digital control panel are:

- Visualization of the baking chamber temperatures (average top and bottom).
- Top and bottom temperatures setting of baking programmes p1 or p2 (see ex. nr.1).
- Baking timer setting and activation (see ex. nr 2).
- Delayed switch-on setting and activation (see ex. nr 3).

GENERAL INDICATIONS FOR A GOOD COOKING

Generally for the food products it is not advisable to give precise temperature and baking time, because of their different characteristics. Particularly, regarding pizza and similar products, time and temperatures depend on the shape and thickness of the dough, as well as on the quantity and typology of the additional ingredients. For those reasons it is always advisable to carry out previously some baking tests, (particularly when it is an absolute new oven), with the aim of understanding as much as possible the characteristics and the functioning of the oven.

Ideal time and temperature choice is determinant for a right pizza baking; mostly they depend on the operator's experience.

WORKING PHASE

While working, at any time the oven can be modified in its temperature parameters and programs; in addition, pizza baking operation can be verified by inner chamber light. Once the oven has reached the set temperature (visible on the display), it is possible to put in the pizza/s for baking, proceeding as follows:

- Open the door of the oven by the suitable handles.
- To light the inner chamber, set the lighting button (B) in the position "1".
- Put in the oven the pizza/s to bake with suitable instruments for said use.
- Close the door again by the suitable handles and check the baking through the door glass. If wished, it is possible to set the baking timer, which will warn with an acoustic signal the set baking time expiry.
- At baking over, open the door by the suitable handles and take out the pizza/s by suitable instruments for said use.

When opening the door while the oven is on, it is important to stay at the right distance, to avoid being invested by the heat coming out from the chamber.

Use suitable instruments to bake in and displace the pizzas in the baking chamber, to avoid burns.

When opening the door to bake the pizza/s, do not leave it opened for long time, to avoid heat dispersion and consequently chamber temperature drop.

Avoid oil and fats to drop on bottom; if brought at high temperature can burn.

QUICK PROGRAM ACCESS

Press the TOP key to access the temperature setpoints related to program 1 (parameters P3 and P4), press instead the BOTTOM key to access the temperature setpoints related to program 2 (parameters P5 and P6). When pressing the TOP or BOTTOM key, the display shows the selected program for 5 seconds (Pr 1 in green or Pr 2 in red). The setpoints are updated when the label disappears. If while Pr 1 or Pr 2 is displayed the TOP or BOTTOM key is pressed, this display will disappear and the setpoints are updated. With the card ON, press the TOP and BOTTOM keys for 3 seconds to display the program in use for 5 seconds. The selected program is maintained also if the card is set to OFF or if the power is interrupted.

Operation

SETTING THE DATE AND TIME

The date and time must be set when the expansion with RTC is used for delayed start (parameter P20 = 2). With the card OFF, press the CLOCK key for 3 seconds, and the display will show the label dd followed by the day of the week from 1 to 7 (1= Monday, 7 = Sunday). Use the UP and DOWN keys to set the day of the week and confirm by pressing the CLOCK key. Set the hours (label hh) and minutes (label mm) in the same way. After confirming the minutes with the CLOCK key, the card will return to OFF.

NOTE: if P20=2, but the correct expansion is not installed (with RTC) an error is displayed (RTC label flashing) at the end of the date and time setting procedure.

SETTING DELAYED START

The delayed start can be set only when the card is on and the timer is not being used for counting. Delayed start can be set for the same day and for the following 6 days (for example, on Wednesday it is possible to set the programmed start until maximum next Tuesday). From the day on which the first delayed start is set, the card will turn on EVERY DAY at the set time until the delayed start is turned off. Press the CLOCK key for 3 seconds, the display will show the flashing dd label followed by the day of the week from 0 to 7 (0=delayed start off, 1=Monday, 7=Sunday). Use the UP and DOWN keys to set the day of the week and confirm by pressing the CLOCK key. Set the hours (flashing hh label) and minutes (flashing mm label) in the same way. After confirming the minutes with the CLOCK key, the card will turn OFF and with the clock icon on and the central dotpoints flashing. To display the programmed start date, press the CLOCK key and the day of the week, time and minutes of the programmed start time will be displayed. The card can be used by pressing the ON/OFF key and setting it to the on status. If the card is turned off, the indication of the delayed start will be redisplayed (flashing dotpoints and clock icon on). To disable the programmed start, turn on the card, access the delayed start setting and disable it by setting dd to zero.

NOTE: If the card turns on in error because the user forgot to turn off the daily delayed start, the oven will turn off automatically after P23 hours after starting if no key is pressed. Set P23=0 to disable this function.

USE OF EXHAUSTER VALVE

By the exhauster valve the operator can regulate the baking steams and fumes flow out from the baking chamber, while in the same the heat is kept. It is advisable to keep the valve fully closed when the oven is under heating; so, the set temperature is reached in shortest possible time. While baking regulate the valve according to the exigencies.

SHUT DOWN PHASE

To shut down the oven, press the power button on the digital control panel and then turn the main switch to the position "0".

MECHANICAL OVEN START UP AND USE

COMMAND PANEL DESCRIPTION

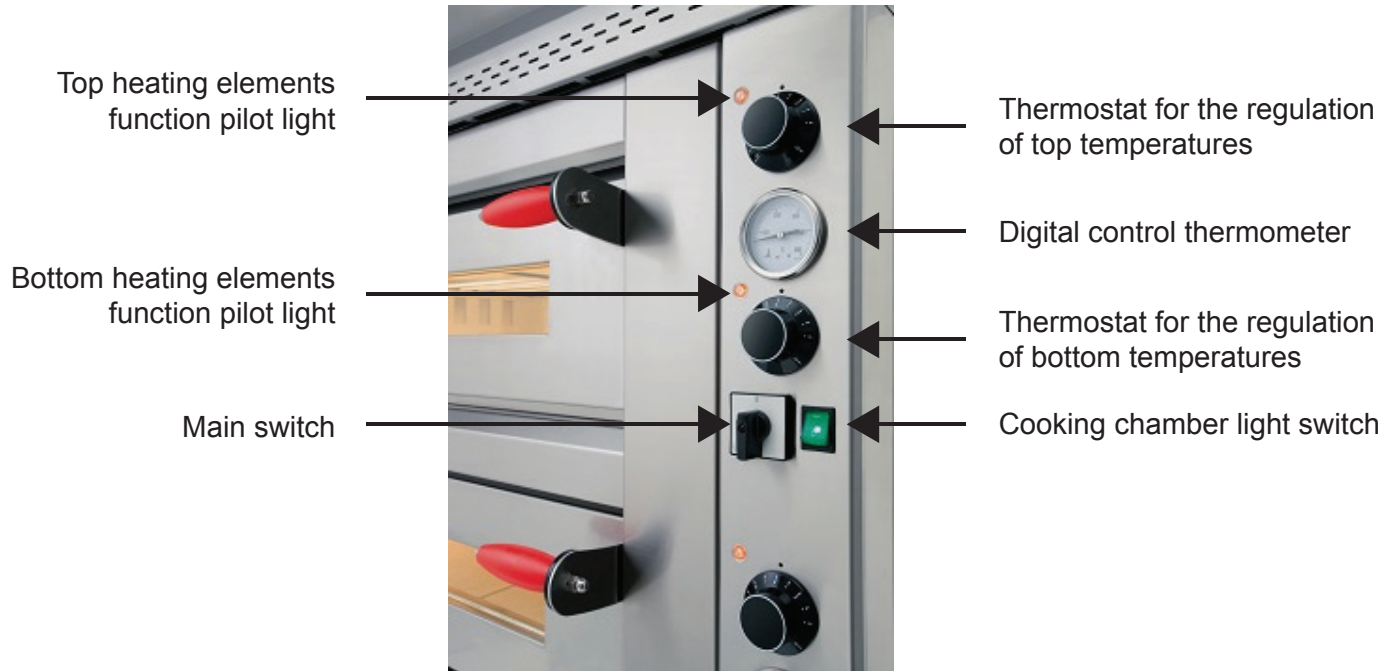

FIRST LIGHTING OF THE OVEN

At the first use of the appliance it is advisable to heat the empty oven to eliminate bad smells caused by the refractory stones evaporation and the inner metallic parts.

Procedure:

- Fully open the exhauster valve.
- Set the main switch in the position “1” after checking that the oven is connected with the power supply.
- Leave the oven working (empty) for at least 8 hours at the temperature of 300° before proceeding to the first baking.

START UP PHASE

After connecting the oven to the electric net rotate the main switch in position “1”. The digital thermometer display shows the actual average temperature of the baking chamber. Rotate the thermostat knobs and until the expected temperature. In this way top and bottom heating elements are under working and the relevant light signals switch on.

GENERAL INDICATIONS FOR A GOOD COOKING

Generally for the food products it is not advisable to give precise temperature and baking time, because of their different characteristics. Particularly, regarding pizza and similar products, time and temperatures depend on

Operation

the shape and thickness of the dough, as well as on the quantity and typology of the additional ingredients. For those reasons it is always advisable to carry out previously some baking tests, (particularly when it is an absolute new oven), with the aim of understanding as much as possible the characteristics and the functioning of the oven.

Ideal Time and temperature choice is determinant for a right pizza baking; mostly they depend on the operator's experience.

WORKING PHASE

While working, at any time the oven can be modified in its temperature parameters; in addition, pizza baking operation can be verified by inner chamber light. Once the oven has reached the set temperature (visible on the display), it is possible to put in the pizza/s for baking, proceeding as follows:

- Open the door of the oven by the suitable handles.
- To light the inner chamber, set the lighting button (B) in the position "1".
- Put in the oven the pizza/s to bake with suitable instruments for said use.
- Close the door again by the suitable handles and check the baking through the door glass.
- At baking over, open the door by the suitable handles and take out the pizza/s by suitable instruments for said use.

When opening the door while the oven is on, it is important to stay at the right distance, to avoid being invested by the heat coming out from the chamber.

Use suitable instruments to bake in and displace the pizzas in the baking chamber, to avoid burns.

When opening the door to bake the pizza/s, do not leave it opened for long time, to avoid heat dispersion and consequently chamber temperature drop.

Avoid oil and fats to drop on bottom; if brought at high temperature can burn.

USE OF EXHAUSTER VALVE

While baking regulate the valve according to the exigencies. Oven is under heating; so, the set temperature is reached in shortest possible time. By the exhauster valve the operator can regulate the baking steams and fumes flow out from the baking chamber, while in the same the heat is kept.

SHUT DOWN PHASE

To shut down the oven turn the main switch to the position "0".

Before performing any maintenance operations, including cleaning, take the following precautions:

- Ensure that the oven is not working and completely cold.
- Ensure that the electrical power is not present.
- Make certain that the electrical power cannot be accidentally reinserted. Disconnect the plug from the electrical power socket.
- Use individual protection devices in compliance with the directive 89/391/CEE.
- Always operate using appropriate maintenance tools.
- Once maintenance and repairs are finished, before starting up the oven, reinstall all of the protection devices and reactivate all of the safety devices.

ORDINARY MAINTENANCE FOR THE USER

As any equipment also our ovens requires simple, frequent and careful cleaning to ensure efficient, regular functioning.

It is recommended to never use chemical products which are not specific for food preparation areas, abrasives or corrosives for any reason. Avoid by all means using water jets, tools, rough or abrasive instruments, such as steel wool, brillo sponges or any other item which could damage the surface of the machine, and especially those that could compromise health safety.

CLEANING OF REFRACTORY PLAN

The oven must be cleaned at the end of each use, in compliance with the hygiene regulations and to safeguard machine operation. Before proceeding the oven temperature must be at 350° C for roughly 60 minutes (setting 350° on the top and on the bottom as well), for an easy baking scoriae carbonization. Once reached the temperature, switch off the oven and wait until the temperature drops until roughly 100°C (the best temperature for cleaning). At this stage disconnect the electric power supply. After dressing in gloves and suitable dresses as protection from burns, open the door and by a brush in natural fiber with a long handle, proceed to a first removal of baking fragments from the refractory stones, then take them out by a suitable vacuum cleaner. At the end, clean the refractory stone with an humid cloth.

EXTERNAL CLEANING OF THE OVEN

Oven external areas cleaning, external parts in stainless steel, door glass, and switch panel, must be carried out at cold oven and at disconnected electric power supply. Use a sponge or a soft cloth, not abrasive, slightly humidified with water or possibly with a neutral detergent not corrosive. In any case, do not use water jets which can penetrate through the electric parts and heavily damage them, as well as bring a possible danger for people.

Troubleshooting

WORKING ERRORS

SYMPTOM	POSSIBLE CAUSE	SUGGESTED REMEDY
The oven does not switch on.	No electric Energy in the net.	Check the general contactor, the socket, the plug, and the supply cable.
	Main switch off (positioned on "0").	Rotate the main switch to position "1".
The display is off in spite of the main switch being on position 1 and the electric supply is in order.	Digital thermo/timer defective.	Replace the digital thermo/timer.
Inner light bulb does not switch on.	Burned inner light bulb.	Replace inner light bulb.
	Inner light bulb switch defected.	Replace light bulb switch.
	No electric supply power on the light bulb.	Check electric connection with the light bulb.
The door is closed, but fume comes out.	Exhauster butterfly valve closed.	Open more the valve and check the right functioning.
The baking chamber does not heat suitably.	The set temperature are too low.	Set the right temperature.
The baking chamber does not heat suitably in spite of the temperature being set rightly.	One or more heating elements are defected.	Replace the defective heating elements.
The temperature continues going up over the set by thermo/timer.	Power card contactors contacts blocked (heating elements always supplied).	Check and, if necessary, replace contactors card.
	Thermo/timer contacts defective.	Check and if necessary replace the thermo/timer.

CONTROLLER ERRORS

DISPLAY ALARMS	ALARMS MEANING	POSSIBLE CAUSES	EFFECT	SOLUTIONS
ER1	Top probe damage or probe connection anomaly.	Top probe defective or anomaly probe connection.	Top heating elements disconnection and intermittent buzzer sound.	Connect again and/or replace the top probe.
ER2	Bottom probe damage or probe connection anomaly.	Bottom probe damaged or probe connection anomaly.	Bottom heating elements disconnection and buzzer intermittent sound.	Connect again and/or replace the bottom probe.

Troubleshooting

ERR	Card probe damage.	Card probe damage.	All heating elements disconnection (top and bottom) and buzzer intermittent sound.	Replace the card probe.
HIT	Probe temperature too high.	Insufficient oven air circulation due to non respect of the minimum distances from surrounding walls.	Disconnection of all heating elements (top and bottom) and intermittent buzzer sound.	Wait until the temperature of the switch panel area decreases below the security temperature and check the causes of the overheating.
		Power card contactor contacts blocked (heating elements always power supplied).	Disconnection of all heating elements (top and bottom) and intermittent buzzer sound.	
		Switch panel cooling fan damage (the fan is fitted in some models only).	Disconnection of all heating elements (top and bottom) and intermittent buzzer sound.	

REFERENCE

Item Number	Model Number	Description	Manufacturer Model Number
40637	PE-IT-0024-S	Pizza Oven Pyralis Series Single Chamber 27.5" x 27.5" x 5.9" 220/60/3 Pyralis M4 cQPSus	PYRALIS M4
40638	PE-IT-0048-D	Pizza Oven Pyralis Series Double Chamber 27.5" x 27.5" x 5.9" 220/60/3 Pyralis M8 cQPSus	PYRALIS M8
40641	PE-IT-0049-D	Pizza Oven Pyralis Series Double Chamber 27.5" x 41.3" x 5.9" 220/60/3 Pyralis M12L cQPSus	PYRALIS M12L
40643	PE-IT-0049-DD	Pizza Oven Pyralis Series Double Chamber 41.3" x 27.5" x 5.9" 220/60/3 Pyralis D12L cQPSus	PYRALIS D12L

Parts Breakdown

Model PE-IT-0024-S 40637

Model PE-IT-0048-D 40638

Model PE-IT-0049-D 40641

Model PE-IT-0049-DD 40643

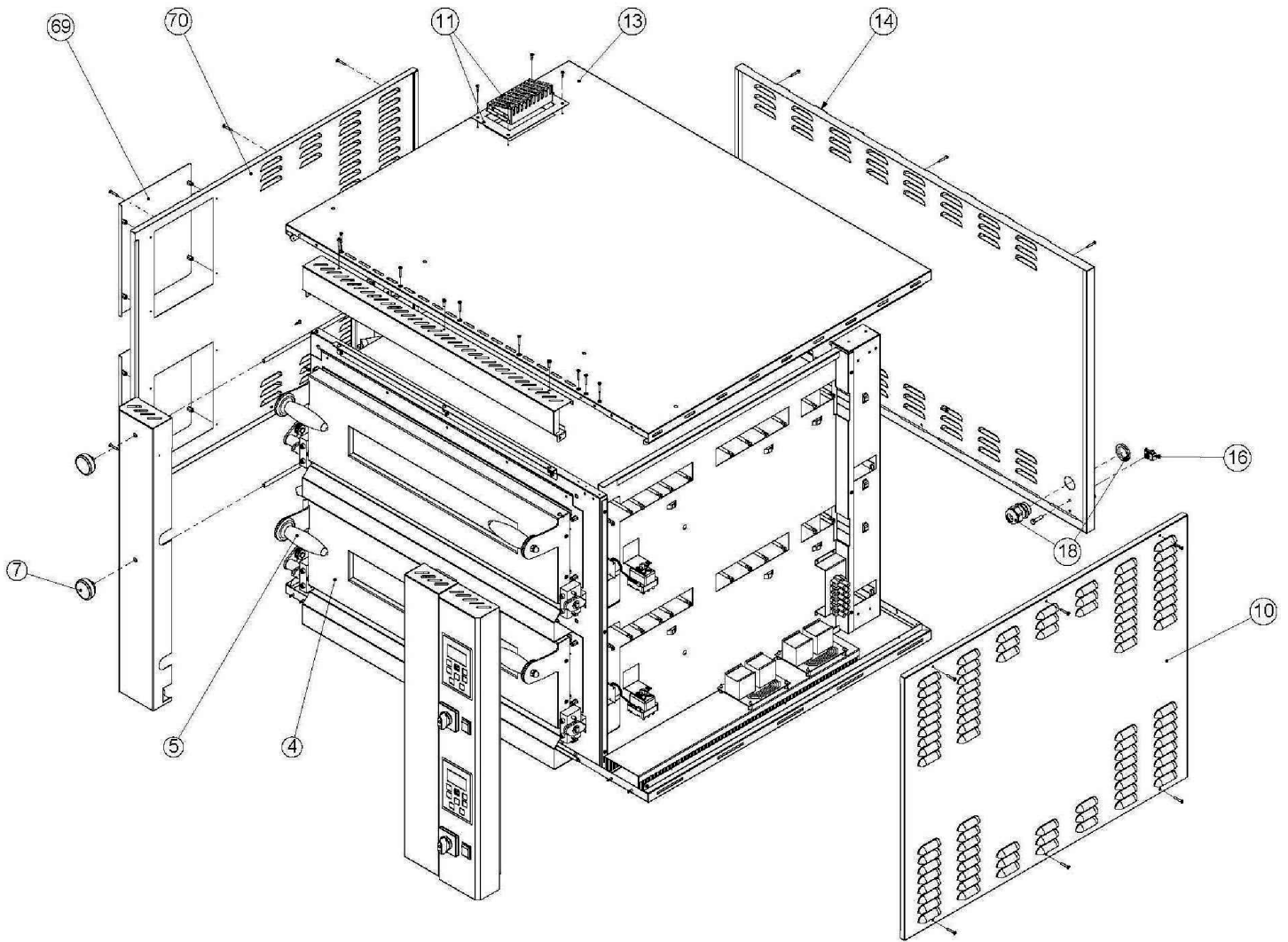

Parts Breakdown

- Model PE-IT-0024-S** 40637
- Model PE-IT-0048-D** 40638
- Model PE-IT-0049-D** 40641
- Model PE-IT-0049-DD** 40643

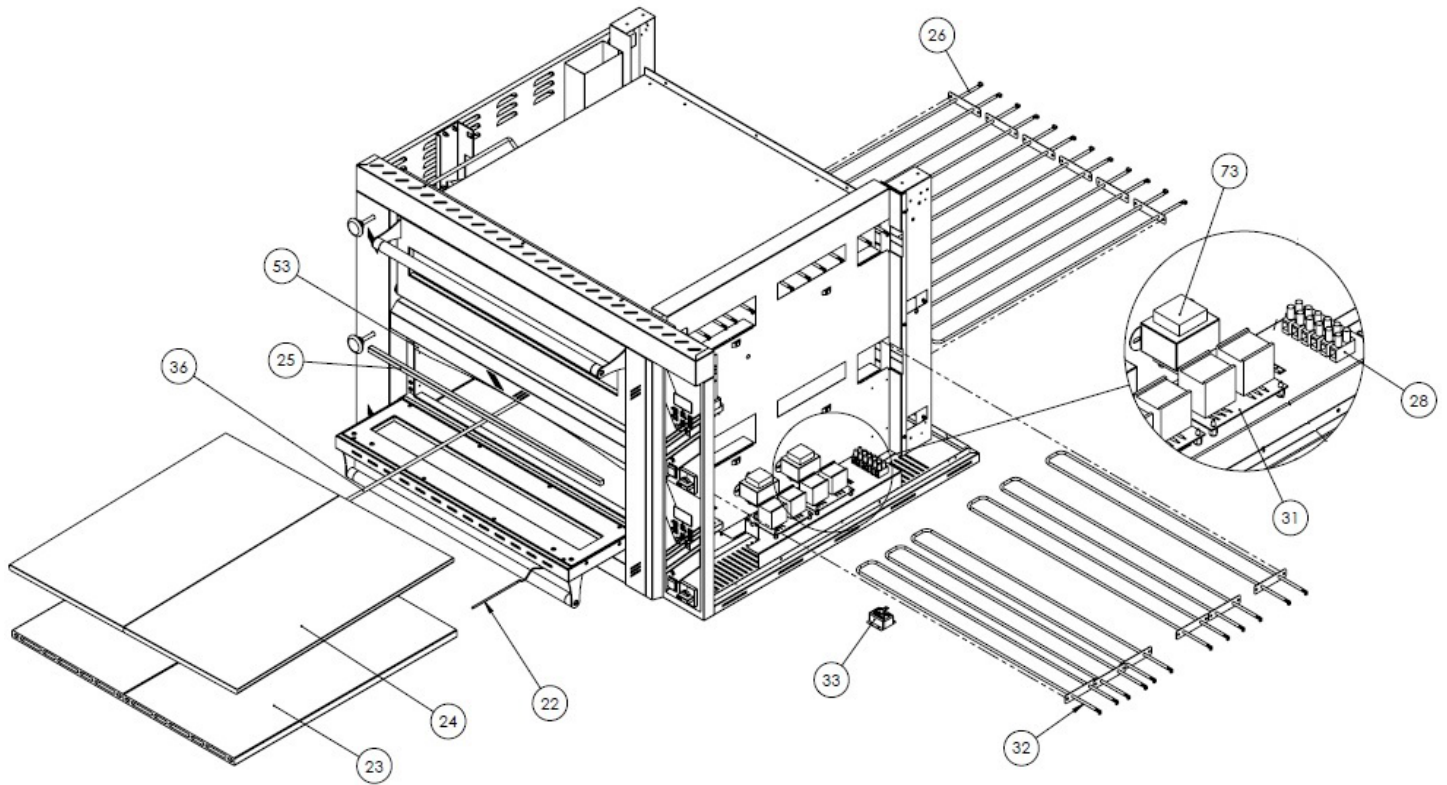

Parts Breakdown

Model PE-IT-0024-S 40637

Model PE-IT-0048-D 40638

Model PE-IT-0049-D 40641

Model PE-IT-0049-DD 40643

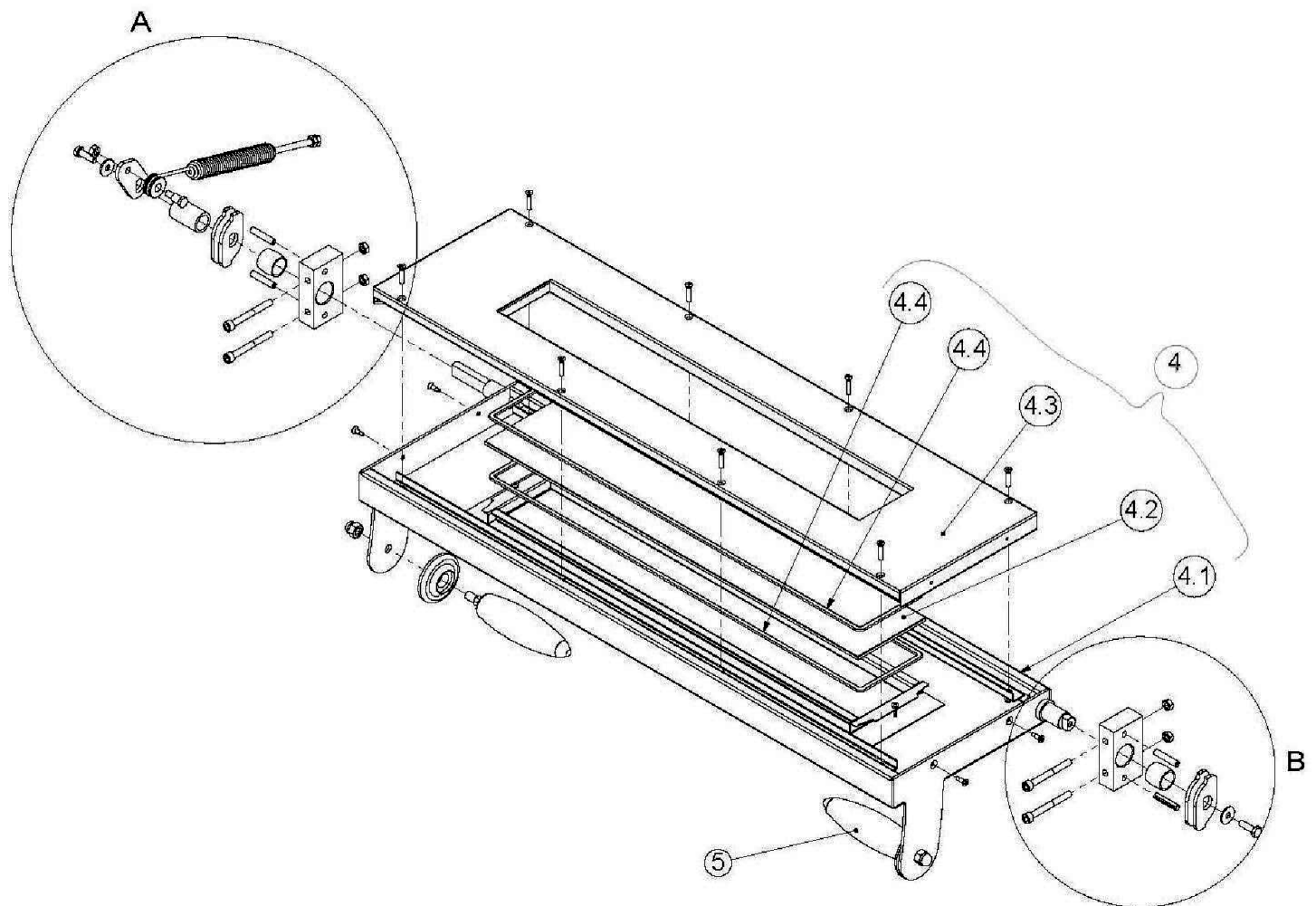

Parts Breakdown

- Model PE-IT-0024-S** 40637
- Model PE-IT-0048-D** 40638
- Model PE-IT-0049-D** 40641
- Model PE-IT-0049-DD** 40643

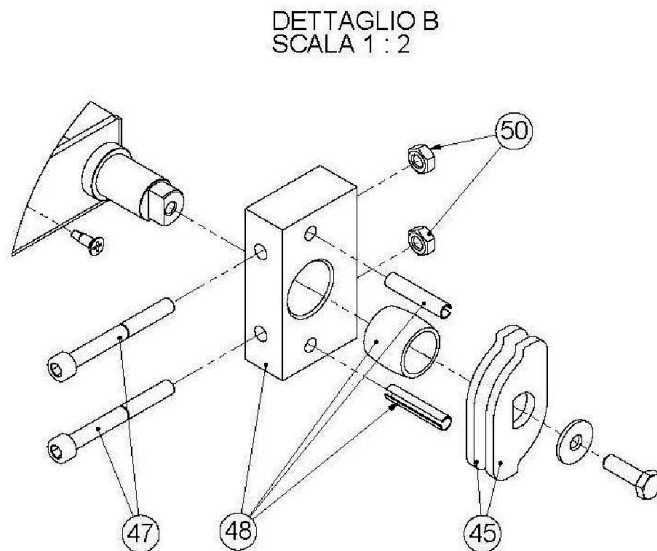
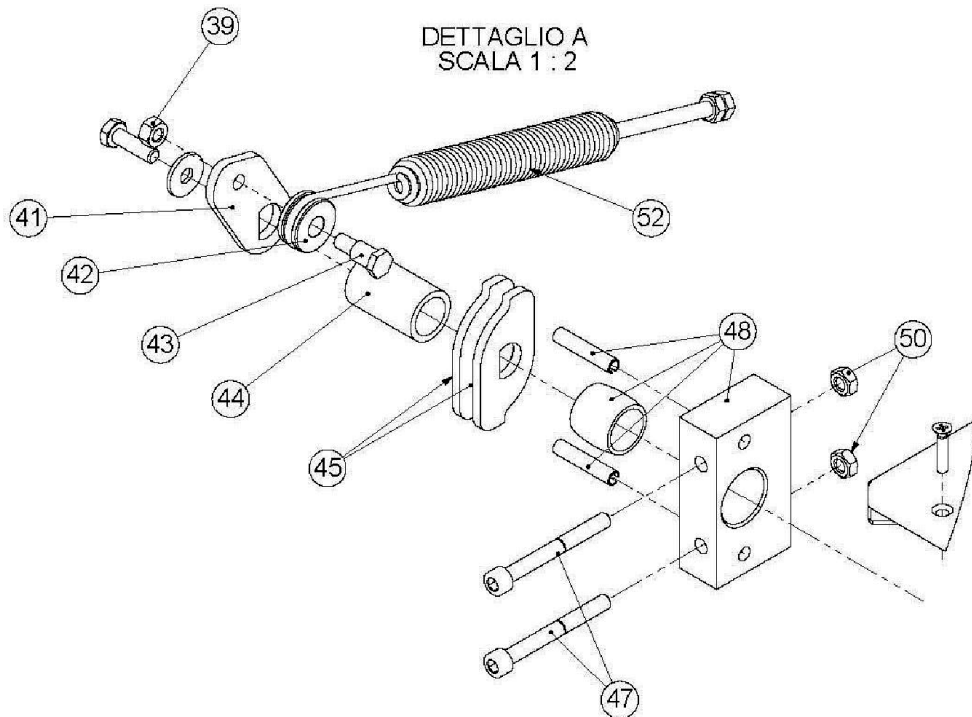

Parts Breakdown

Model PE-IT-0024-S 40637

Model PE-IT-0048-D 40638

Model PE-IT-0049-D 40641

Model PE-IT-0049-DD 40643

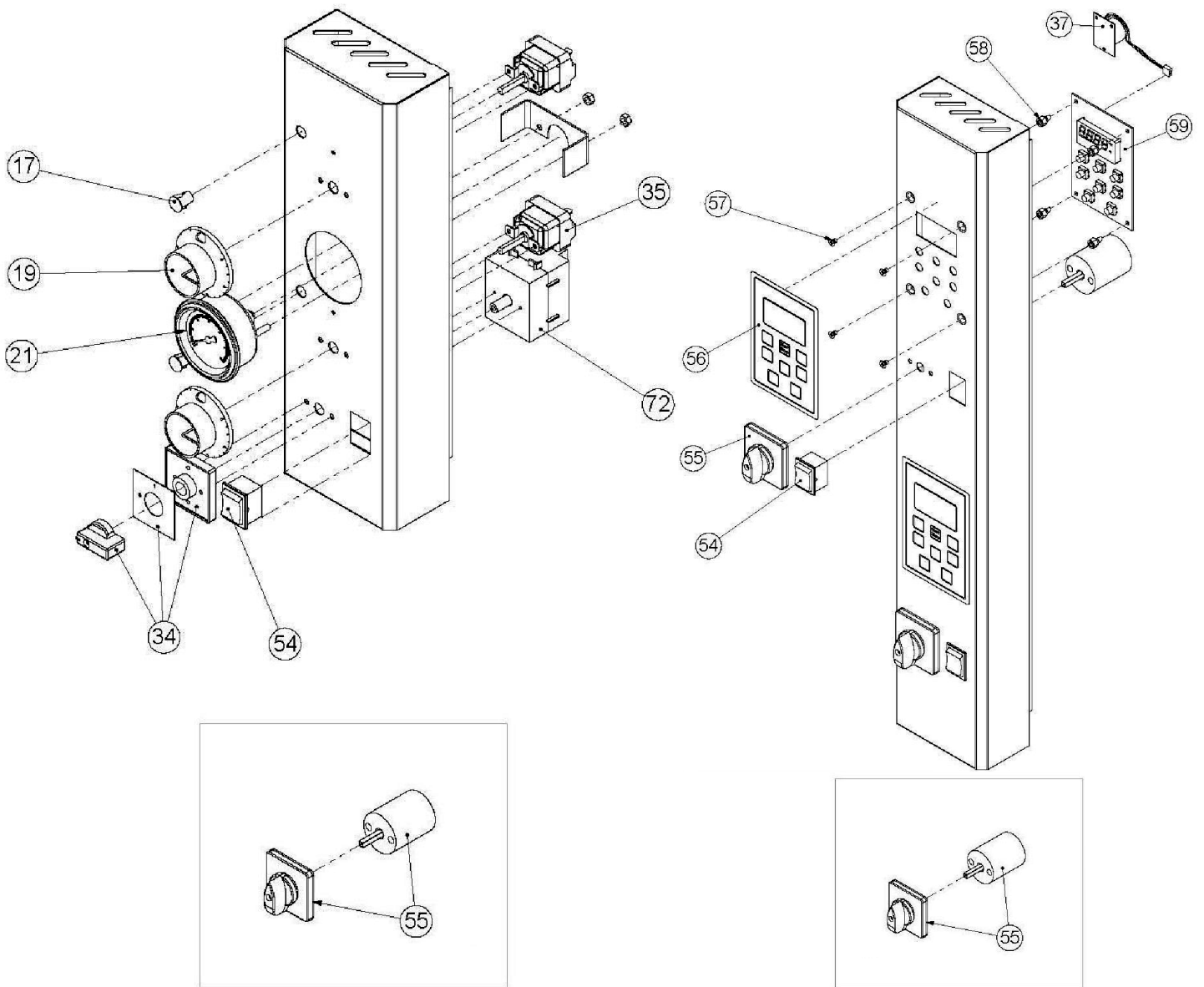

Parts Breakdown

- Model PE-IT-0024-S** 40637
- Model PE-IT-0048-D** 40638
- Model PE-IT-0049-D** 40641
- Model PE-IT-0049-DD** 40643

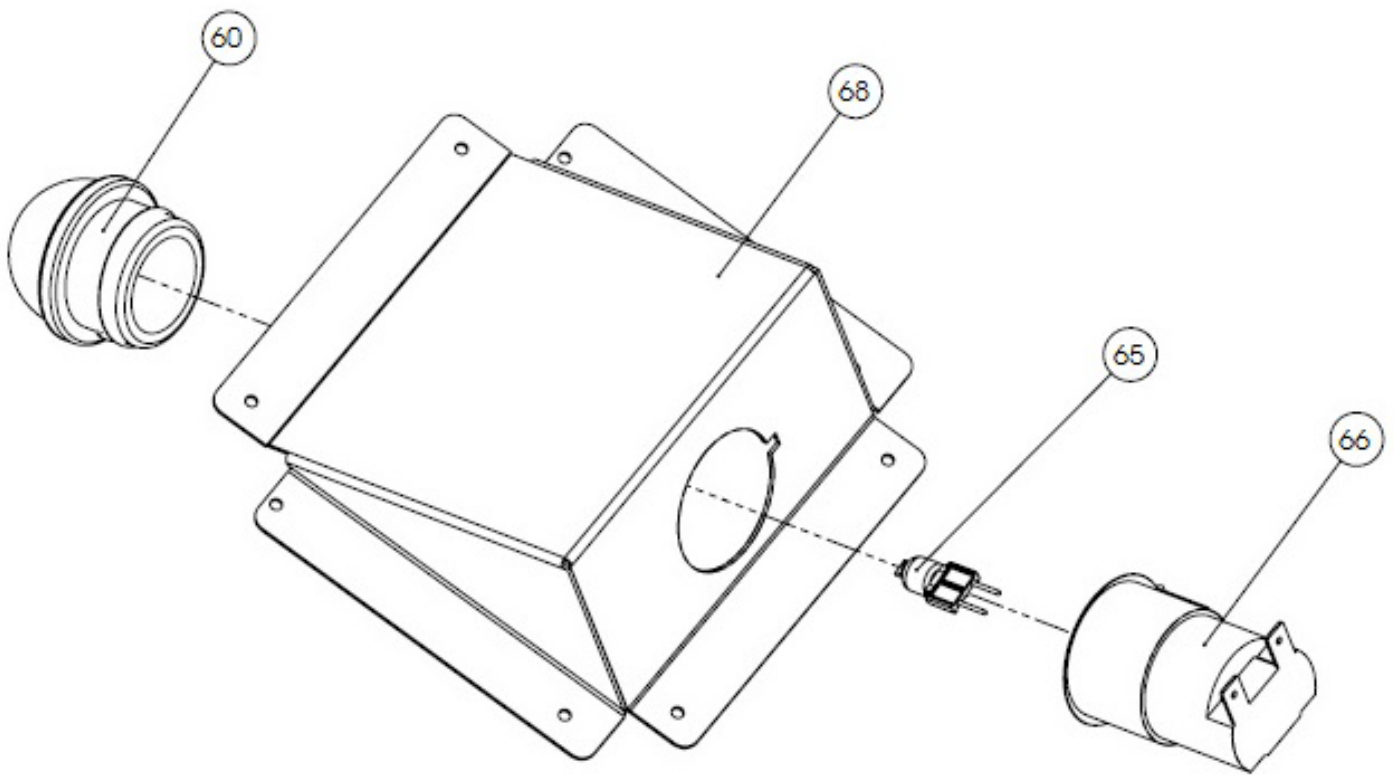

Parts Breakdown

Model PE-IT-0024-S 40637

Item No.	Description	Position	Item No.	Description	Position	Item No.	Description	Position
76630	Complete Oven Door for Pyralis M4	4	74750	Probe T4JA44VH25IPD-F S/M 600° for Pyralis M4	22	74770	Door Spline Shim for Pyralis M4	44
77257	Door Assembly for Pyralis M4	4.1	44772	Perforated Block 700x350x22 for Pyralis M4	23	74767	Door Retainer Spline for Pyralis M4	45
76632	Professional Glass Ceramic Sheet for Pyralis M4	4.2	76650	Block 350x700x14 for Pyralis M4	24	74772	Countersunk Hex Head Screw M6x55 for Pyralis M4	47
76633	Oven Door-Frame Assembly for Pyralis M4	4.3	74753	Cord for Pyralis M4	25	74773	Door Fixing Block for Pyralis M4	48
74801	Tape in White Glass Fibre with Adhesive 6x2mm for Pyralis M4	4.4	42041	Resistance 400 W 230 V for Pyralis M4	26	74774	Door Rotation Bush for Pyralis M4	48
74737	Oven Door Handle Assembly for Pyralis M4	5	42831	Terminal Board PA220FV 12 Poles 16sqmm 750V-76A for Pyralis M4	28	74775	Shot Pin Ø 3x16 for Pyralis M4	48
74738	Lobed Hand Wheel for Pyralis M4	7	42030	Pizza Oven Relays Board for Pyralis M4	31	74776	Hexagonal Nut DIN 934 M6 for Pyralis M4	50
76637	Oven Side Panel for Pyralis M4	10	42042	Resistance 700 W 230 V for Pyralis M4	32	42033	Professional Spring for Pyralis M4	52
74740	Plaque for Flue Cover for Pyralis M4	11	74824	Unipolar Safety Thermostat for Pyralis M4	33	74778	Cord Support for Pyralis M4	53
74741	Flue Cover Assembly for Pyralis M4	11	74760	Actuator 48x48 Grey/Black INT.Mask 32A for Pyralis M4	34	42844	Luminous Bi-Polar Switch 0-1 CV2 for Pyralis M4	54
77266	Superior Cover for Pyralis M4	13	42050	EGO Unipolar Thermostat for 470° Ovens Bulb 163mm for Pyralis M4	35	42035	16 A Actuator P0160004R001 4-Polar Switch for Pyralis M4	55
76641	Rear Panel for Pyralis M4	14	74762	Heaters Support for Pyralis M4	36	42046	Dome-Form Lamp Glass 77.222.-503.00 for Pyralis M4	60
42837	Equipotential Attachment (OBO. T5012+OBO.5016M5) for Pyralis M4	16	77287	Washer Ø 6.4 DIN 9021 for Pyralis M4	38	74855	Halogen Bulb 12V 20W G4 for Pyralis M4	65
42848	Transparent LED Bulb 380V (Including Hood) for Pyralis M4	17	74765	Self-Locking Nut M6 DIN 980 V for Pyralis M4	39	74856	Bulb Holder G4 12V 20W BJB 77.912 for Pyralis M4	66
74746	Nut for Cable Gland OBO 106 PG 11 for Pyralis M4	18	74766	Hex Head Nut DIN 933 M6x20 for Pyralis M4	40	74858	Bulb Holder Support for Pyralis M4	68
74747	Cable Gland OBO 106 PG 21 for Pyralis M4	18	74767	Spring Fixing Spline for Pyralis M4	41	42036	Actuator 32A Switch for Pyralis M4	72
42049	AP10 Pizzagroup Oven (°C) Thermostat Knob for Pyralis M4	19	74768	Wheel Rotation Pin Professional Release 2011 for Pyralis M4	42	62493	Transformer 40VA 50/60HZ 230V-12V for Pyralis M4	73
74749	Thermometer Ø 60 TAR. 0+500°C for Pyralis M4	21	74769	Spring Rotation Wheel Professional Release 2011 for Pyralis M4	43			

Parts Breakdown

Model PE-IT-0048-D 40638

Item No.	Description	Position	Item No.	Description	Position	Item No.	Description	Position
76630	Complete Oven Door for Pyralis M8	4	74750	Probe T4JA44VH25IPD-F S/M 600° for Pyralis M8	22	74770	Door Spline Shim for Pyralis M8	44
77257	Door Assembly for Pyralis M8	4.1	44772	Perforated Block 700x350x22 for Pyralis M8	23	74767	Door Retainer Spline for Pyralis M8	45
76632	Professional Glass Ceramic Sheet for Pyralis M8	4.2	76650	Block 350x700x14 for Pyralis M8	24	74772	Countersunk Hex Head Screw M6x55 for Pyralis M8	47
76633	Oven Door-Frame Assembly for Pyralis M8	4.3	74753	Cord for Pyralis M8	25	74773	Door Fixing Block for Pyralis M8	48
74801	Tape in White Glass Fibre with Adhesive 6x2mm for Pyralis M8	4.4	42041	Resistance 400 W 230 V for Pyralis M8	26	74774	Door Rotation Bush for Pyralis M8	48
74737	Oven Door Handle Assembly for Pyralis M8	5	42831	Terminal Board PA220FV 12 Poles 16sqmm 750V-76A for Pyralis M8	28	74775	Shot Pin Ø 3x16 for Pyralis M8	48
74738	Lobed Hand Wheel for Pyralis M8	7	42030	Pizza Oven Relays Board for Pyralis M8	31	74776	Hexagonal Nut DIN 934 M6 for Pyralis M8	50
74739	Oven Side Panel for Pyralis M8	10	42042	Resistance 700 W 230 V for Pyralis M8	32	42033	Professional Spring for Pyralis M8	52
74740	Plaque for Flue Cover for Pyralis M8	11	74824	Unipolar Safety Thermostat for Pyralis M8	33	74778	Cord Support for Pyralis M8	53
74741	Flue Cover Assembly for Pyralis M8	11	74760	Actuator 48x48 Grey/Black INT.Mask 32A for Pyralis M8	34	42844	Luminous Bi-Polar Switch 0-1 CV2 for Pyralis M8	54
77266	Superior Cover for Pyralis M8	13	42050	EGO Unipolar Thermostat for 470° Ovens Bulb 163mm for Pyralis M8	35	42035	16 A Actuator P0160004R001 4-Polar Switch for Pyralis M8	55
74743	Oven Rear Panel for Pyralis M8	14	74762	Heaters Support for Pyralis M8	36	42046	Dome-Form Lamp Glass 77.222.-503.00 for Pyralis M8	60
42837	Equipotential Attachment (OBO. T5012+OBO.5016M5) for Pyralis M8	16	77287	Washer Ø 6.4 DIN 9021 for Pyralis M8	38	74855	Halogen Bulb 12V 20W G4 for Pyralis M8	65
42848	Transparent LED Bulb 380V (Including Hood) for Pyralis M8	17	74765	Self-Locking Nut M6 DIN 980 V for Pyralis M8	39	74856	Bulb Holder G4 12V 20W BJB 77.912 for Pyralis M8	66
74746	Nut for Cable Gland OBO 106 PG 21 for Pyralis M8	18	74766	Hex Head Nut DIN 933 M6x20 for Pyralis M8	40	74858	Bulb Holder Support for Pyralis M8	68
74747	Cable Gland OBO 106 PG 21 for Pyralis M8	18	74767	Spring Fixing Spline for Pyralis M8	41	42036	Actuator 32A Switch for Pyralis M8	72
42049	AP10 Pizzagroup Oven (°C) Thermostat Knob for Pyralis M8	19	74768	Wheel Rotation Pin Professional Release 2011 for Pyralis M8	42	62493	Transformer 40VA 50/60HZ 230V-12V for Pyralis M8	73
74749	Thermometer Ø 60 TAR. 0-500°C for Pyralis M8	21	74769	Spring Rotation Wheel Professional Release 2011 for Pyralis M8	43			

Parts Breakdown

Model PE-IT-0049-D 40641

Item No.	Description	Position	Item No.	Description	Position	Item No.	Description	Position
74732	Complete Oven Door for Pyralis M12L	4	74750	Probe T4JA44VH25IPD-F S/M 600° for Pyralis M12L	22	74770	Door Spline Shim for Pyralis M12L	44
74733	Complete Oven Assembly for Pyralis M12L	4.1	44772	Perforated Block 700x350x22 for Pyralis M12L	23	74767	Door Retainer Spline for Pyralis M12L	45
74734	Glass Ceramic Sheet 865x94x4mm for Pyralis M12L	4.2	76650	Block 350x700x14 for Pyralis M12L	24	74772	Countersunk Hex Head Screw M6x55 for Pyralis M12L	47
74735	Oven Door-Frame Assembly for Pyralis M12L	4.3	74753	Cord for Pyralis M12L	25	74773	Door Fixing Block for Pyralis M12L	48
74801	Tape in White Glass Fibre with Adhesive 6x2mm for Pyralis M12L	4.4	42041	Resistance 400 W 230 V for Pyralis M12L	26	74774	Door Rotation Bush for Pyralis M12L	48
74737	Oven Door Handle Assembly for Pyralis M12L	5	42831	Terminal Board PA220FV 12 Poles 16sqmm 750V-76A for Pyralis M12L	28	74775	Shot Pin Ø 3x16 for Pyralis M12L	48
74738	Lobed Hand Wheel for Pyralis M12L	7	42030	Pizza Oven Relays Board for Pyralis M12L	31	74776	Hexagonal Nut DIN 934 M6 for Pyralis M12L	50
74739	Oven Side Panel for Pyralis M12L	10	74823	Resistance 900 W 230 V for Pyralis M12L	32	42033	Professional Spring for Pyralis M12L	52
74740	Plaque for Flue Cover for Pyralis M12L	11	74824	Unipolar Safety Thermostat for Pyralis M12L	33	74778	Cord Support for Pyralis M12L	53
74741	Flue Cover Assembly for Pyralis M12L	11	74760	Actuator 48x48 Grey/Black INT.Mask 32A for Pyralis M12L	34	42844	Luminous Bi-Polar Switch 0-1 CV2 for Pyralis M12L	54
74742	Superior Cover for Pyralis M12L	13	42050	EGO Unipolar Thermostat for 470° Ovens Bulb 163mm for Pyralis M12L	35	42035	16 A Actuator P0160004R001 4-Polar Switch for Pyralis M12L	55
74743	Rear Panel for Pyralis M12L	14	74762	Heaters Support for Pyralis M12L	36	42046	Dome-Form Lamp Glass 77.222.-503.00 for Pyralis M12L	60
42837	Equipotential Attachment (OBO. T5012+OBO.5016M5) for Pyralis M12L	16	74746	Washer Ø 6.4 DIN 9021 for Pyralis M12L	38	74855	Halogen Bulb 12V 20W G4 for Pyralis M12L	65
42848	Transparent LED Bulb 380V (Including Hood) for Pyralis M12L	17	74765	Self-Locking Nut M6 DIN 980 V for Pyralis M12L	39	74856	Bulb Holder G4 12V 20W BJB 77.912 for Pyralis M12L	66
74746	Nut for Cable Gland OBO 106 PG 21 for Pyralis M12L	18	74766	Hex Head Nut DIN 933 M6x20 for Pyralis M12L	40	74858	Bulb Holder Support for Pyralis M12L	68
74747	Cable Gland OBO 106 PG 21 for Pyralis M12L	18	74767	Spring Fixing Spline for Pyralis M12L	41	42036	Actuator 32A Switch for Pyralis M12L	72
42049	AP10 Pizzagroup Oven (°C) Thermostat Knob for Pyralis M12L	19	74768	Wheel Rotation Pin Professional Release 2011 for Pyralis M12L	42	62493	Transformer 40VA 50/60HZ 230V-12V for Pyralis M12L	73
74749	Thermometer Ø 60 TAR. 0-500°C for Pyralis M12L	21	74769	Spring Rotation Wheel Professional Release 2011 for Pyralis M12L	43			

Parts Breakdown

Model PE-IT-0049-DD 40643

Item No.	Description	Position	Item No.	Description	Position	Item No.	Description	Position
74732	Complete Oven Door for Pyralis D12L	4	74753	Cord for Pyralis D12L	25	74774	Door Rotation Bush for Pyralis D12L	48
74733	Complete Oven Assembly for Pyralis D12L	4.1	42041	Resistance 400 W 230 V for Pyralis D12L	26	74775	Shot Pin Ø 3x16 for Pyralis D12L	48
74734	Glass Ceramic Sheet 865x94x4mm for Pyralis D12L	4.2	42831	Terminal Board PA220FV 12 Poles 16sqmm 750V-76A for Pyralis D12L	28	74776	Hexagonal Nut DIN 934 M6 for Pyralis D12L	50
74735	Oven Door-Frame Assembly for Pyralis D12L	4.3	42030	Pizza Oven Relays Board for Pyralis D12L	31	42033	Professional Spring for Pyralis D12L	52
74801	Tape in White Glass Fibre with Adhesive 6x2mm for Pyralis D12L	4.4	74823	Resistance 900 W 230 V for Pyralis D12L	32	74778	Cord Support for Pyralis D12L	53
74737	Oven Door Handle Assembly for Pyralis D12L	5	74824	Unipolar Safety Thermostat for Pyralis D12L	33	42844	Luminous Bi-Polar Switch 0-1 CV2 for Pyralis D12L	54
74738	Lobed Hand Wheel for Pyralis D12L	7	74762	Heaters Support for Pyralis D12L	36	42035	16 A Actuator P0160004R001 4-Polar Switch for Pyralis D12L	55
74739	Oven Side Panel for Pyralis D12L	10	77287	Buzzer Expansion with Cable L=20cm (Code CT1TS0020000) for Pyralis D12L	37	60355	Thermo/Timer "2000" L Label for Pyralis D12L	56
74740	Plaque for Flue Cover for Pyralis D12L	11	74746	Washer Ø 6.4 DIN 9021 for Pyralis D12L	38	74782	Flat Head Screw DIN 964 A M4x6 for Pyralis D12L	57
74741	Flue Cover Assembly for Pyralis D12L	11	74765	Self-Locking Nut M6 DIN 980 V for Pyralis D12L	39	61377	Plastic Shim CF06H4080-1806 for Pyralis D12L	58
74742	Superior Cover for Pyralis D12L	13	74766	Hex Head Nut DIN 933 M6x20 for Pyralis D12L	40	42032	P1-P2 Professional "2009" Thermo/Timer Control Unit for Pyralis D12L	59
74743	Rear Panel for Pyralis D12L	14	74767	Spring Fixing Spline for Pyralis D12L	41	42046	Dome-Form Lamp Glass 77.222.-503.00 for Pyralis D12L	60
42837	Equipotential Attachment (OBO. T5012+OBO.5016M5) for Pyralis D12L	16	74768	Wheel Rotation Pin Professional Release 2011 for Pyralis D12L	42	74855	Halogen Bulb 12V 20W G4 for Pyralis D12L	65
74746	Nut for Cable Gland OBO 106 PG 21 for Pyralis D12L	18	74769	Spring Rotation Wheel Professional Release 2011 for Pyralis D12L	43	74856	Bulb Holder G4 12V 20W BJB 77.912 for Pyralis D12L	66
74747	Cable Gland OBO 106 PG 21 for Pyralis D12L	18	74770	Door Spline Shim for Pyralis D12L	44	74858	Bulb Holder Support for Pyralis D12L	68
74750	Probe T4JA44VH25IPD-F S/M 600° for Pyralis D12L	22	74767	Door Retainer Spline for Pyralis D12L	45	62493	Transformer 40VA 50/60HZ 230V-12V for Pyralis D12L	73
44772	Perforated Block 700x350x22 for Pyralis D12L	23	74772	Countersunk Hex Head Screw M6x55 for Pyralis D12L	47			
76650	Block 350x700x14 for Pyralis D12L	24	74773	Door Fixing Block for Pyralis D12L	48			

Electrical Schematics

Model PE-IT-0024-S 40637

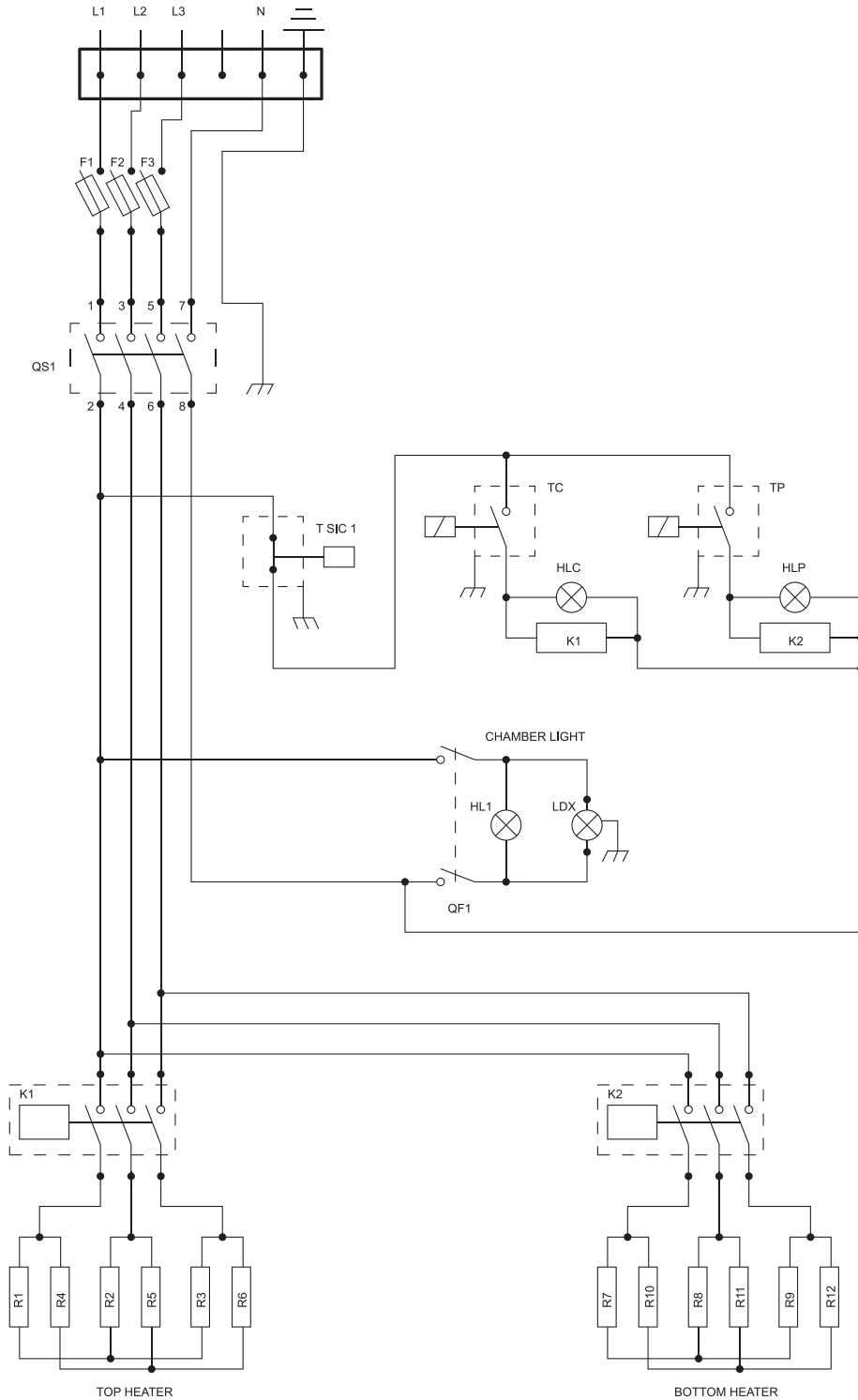

Electrical Schematics

Model PE-IT-0048-D 40638

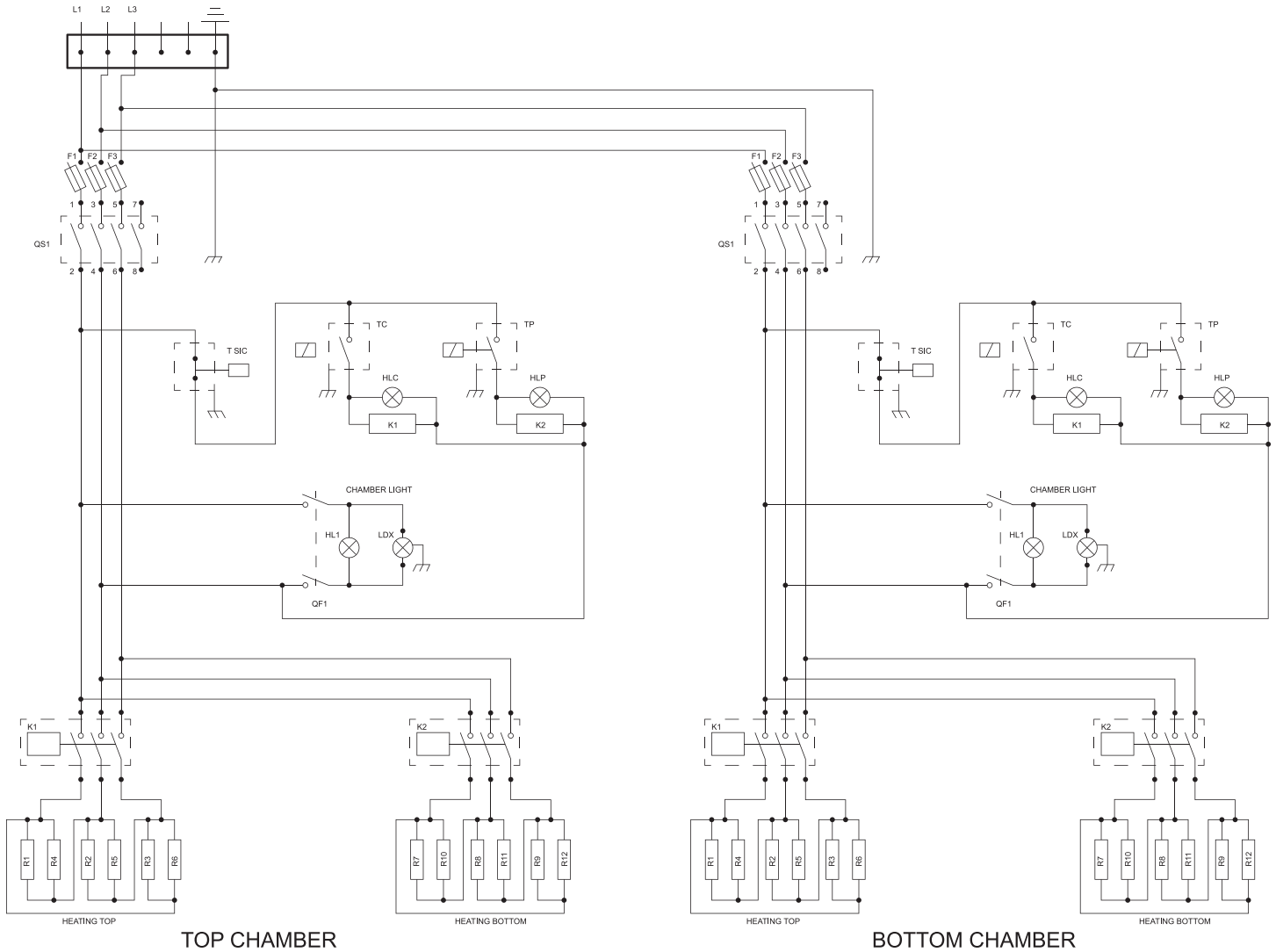

Electrical Schematics

Model PE-IT-0049-D 40641

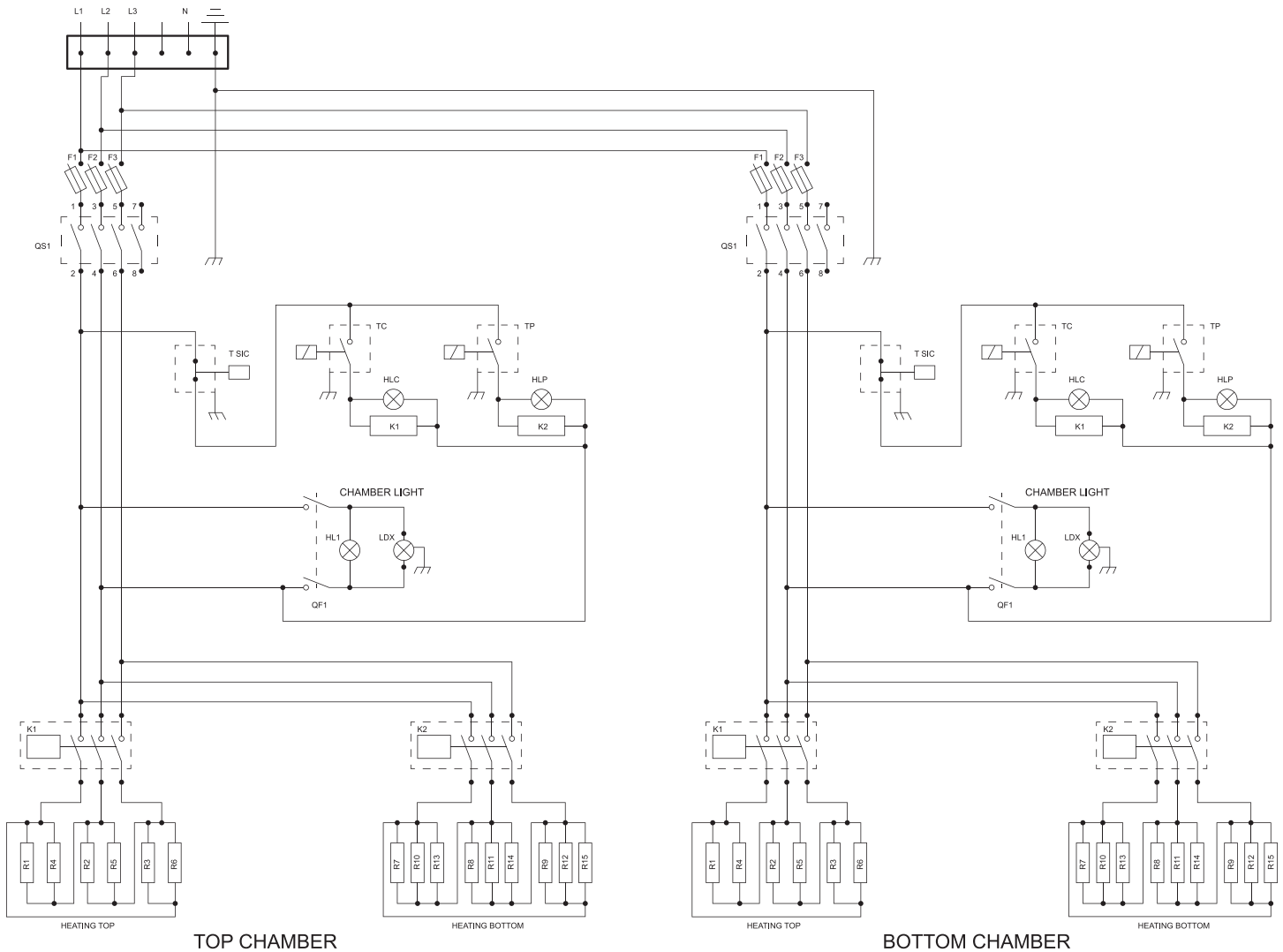

Electrical Schematics

Model PE-IT-0049-DD 40643

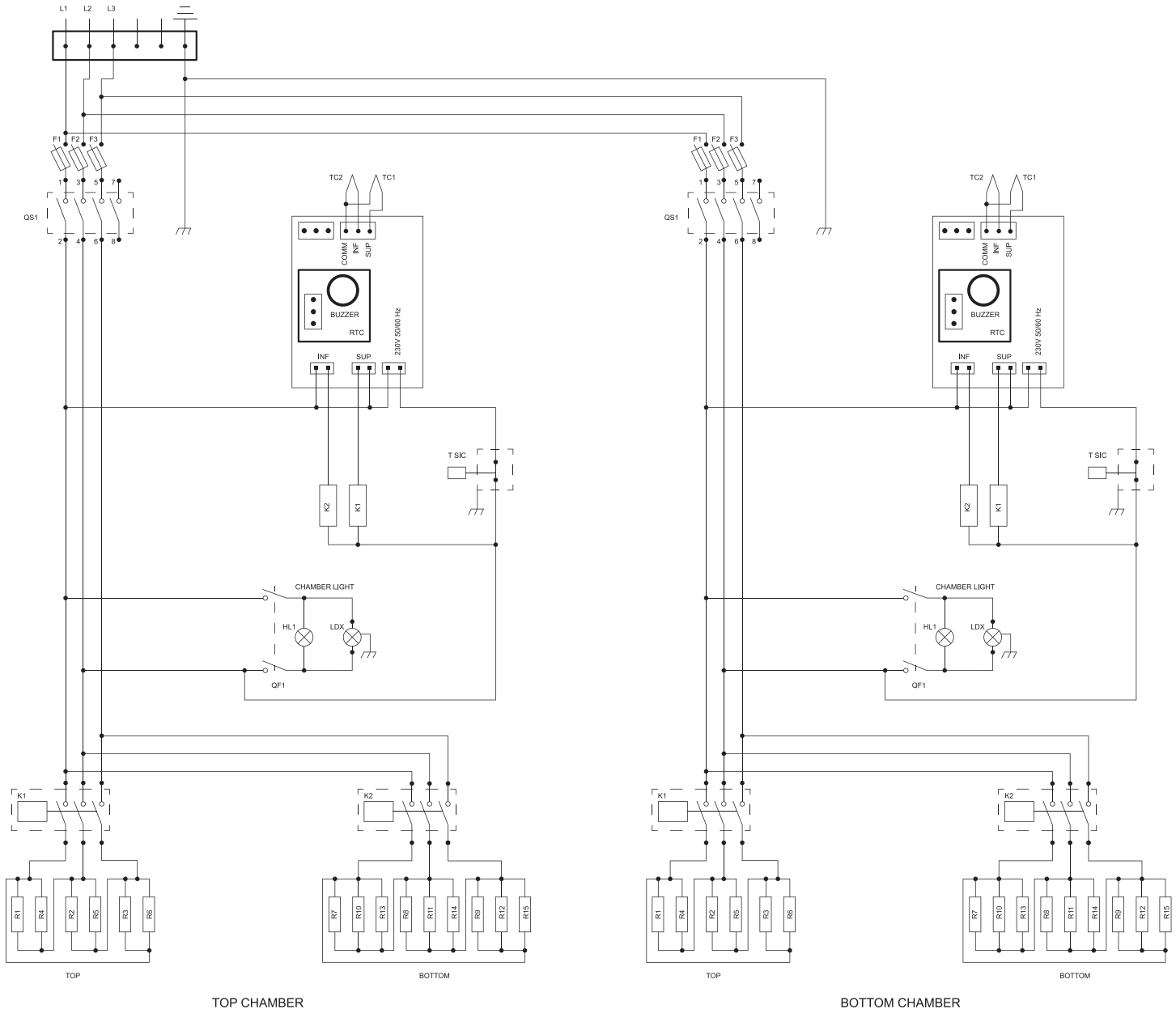



Warranty Registration

Thank you for purchasing an Omcan product. To register your warranty for this product, complete the information below, tear off the card at the perforation and then send to the address specified below. You can also register online by visiting:

Merci d'avoir acheté un produit Omcan. Pour enregistrer votre garantie pour ce produit, complétez les informations ci-dessous, détachez la carte au niveau de la perforation, puis l'envoyer à l'adresse spécifiée ci-dessous. Vous pouvez également vous inscrire en ligne en visitant:

Gracias por comprar un producto Omcan usted. Para registrar su garantía para este producto, complete la información a continuación, cortar la tarjeta en la perforación y luego enviarlo a la dirección indicada a continuación. También puede registrarse en línea en:

<https://omcan.com/warranty-registration/>

For mailing in Canada

Pour postale au Canada

Por correo en Canadá

OMCAN

PRODUCT WARRANTY REGISTRATION

3115 Pepper Mill Court,

Mississauga, Ontario

Canada, L5L 4X5

For mailing in the US

Pour diffusion aux États-Unis

Por correo en los EE.UU.

OMCAN

PRODUCT WARRANTY REGISTRATION

4450 Witmer Industrial Estates, Unit 4,

Niagara Falls, New York

USA, 14305

or email to: service@omcan.com



Purchaser's Information

Name: _____

Address: _____

City: _____ Province or State: _____ Postal or Zip: _____

Country: _____

Dealer from which Purchased: _____

Dealer City: _____ Dealer Province or State: _____

Invoice: _____

Model Name: _____ Model Number: _____

Machine Description: _____

Date of Purchase (MM/DD/YYYY): _____

Would you like to extend the warranty? Yes No

Company Name: _____

Telephone: _____

Email Address: _____

Type of Company:

Restaurant Bakery Deli

Butcher Supermarket Caterer

Institution (specify): _____

Other (specify): _____

Serial Number: _____

Date of Installation (MM/DD/YYYY): _____

Thank you for choosing Omcan | Merci d'avoir choisi Omcan | Gracias por elegir Omcan



Since 1951 Omcan has grown to become a leading distributor of equipment and supplies to the North American food service industry. Our success over these many years can be attributed to our commitment to strengthen and develop new and existing relationships with our valued customers and manufacturers. Today with partners in North America, Europe, Asia and South America, we continually work to improve and grow the company. We strive to offer customers exceptional value through our qualified local sales and service representatives who provide convenient access to over 5,000 globally sourced products.

Depuis 1951 Omcan a grandi pour devenir un des “leaders” de la distribution des équipements et matériel pour l’industrie des services alimentaires en Amérique du Nord. Notre succès au cours de ces nombreuses années peut être attribué à notre engagement à renforcer et à développer de nouvelles et existantes relations avec nos clients et les fabricants de valeur. Aujourd’hui avec des partenaires en Amérique du Nord, Europe, Asie et Amérique du Sud, nous travaillons continuellement à améliorer et développer l’entreprise. Nous nous efforçons d’offrir à nos clients une valeur exceptionnelle grâce à nos ventes locales qualifiées et des représentants de service qui offrent un accès facile à plus de 5000 produits provenant du monde entier.

Desde 1951 Omcan ha crecido hasta convertirse en un líder en la distribución de equipos y suministros de alimentos en América del Norte industria de servicios. Nuestro éxito en estos años se puede atribuir a nuestro compromiso de fortalecer y desarrollar nuevas relaciones existentes con nuestros valiosos clientes y fabricantes. Hoy con socios de América del Norte, Europa, Asia y América del Sur, que trabajan continuamente para mejorar y crecer la empresa. Nos esforzamos por ofrecer a nuestros clientes valor excepcional a través de nuestro local de ventas y representantes de los servicios que proporcionan un fácil acceso a más de 5,000 productos con origen a nivel mundial.

