



Potato Peelers
Models PE-IT-0010, 0018
Items 44184, 44185
Instruction Manual



Revised - 07/04/2018



Toll Free: 1-800-465-0234
Fax: 905-607-0234
Email: service@omcan.com
www.omcan.com

*Optional Refuse
Bin not included.*

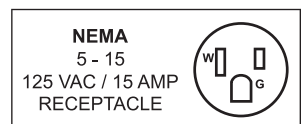

Table of Contents

Model PE-IT-0010 / Model PE-IT-0018

Section	Page
General Information -----	3 - 4
Safety and Warranty -----	4 - 9
Technical Specifications -----	9
Installation -----	9 - 11
Operation -----	11 - 13
Maintenance -----	13 - 15
Troubleshooting -----	15 - 18
Parts Breakdown -----	19 - 21
Electrical Schematics -----	22
Warranty Registration -----	23



General Information

Omcan Manufacturing and Distributing Company Inc., Food Machinery of America, Inc. dba Omcan and Omcan Inc. are not responsible for any harm or injury caused due to any person's improper or negligent use of this equipment. The product shall only be operated by someone over the age of 18, of sound mind, and not under the influence of any drugs or alcohol, who has been trained in the correct operation of this machine, and is wearing authorized, proper safety clothing. Any modification to the machine voids any warranty, and may cause harm to individuals using the machine or in the vicinity of the machine while in operation.

CHECK PACKAGE UPON ARRIVAL

Upon receipt of an Omcan shipment please inspect for external damage. If no damage is evident on the external packaging, open carton to ensure all ordered items are within the box, and there is no concealed damage to the machine. If the package has suffered rough handling, bumps or damage (visible or concealed), please note it on the bill of lading before accepting the delivery and contact Omcan within 24 hours, so we may initiate a claim with the carrier. A detailed report on the extent of the damage caused to the machine must be filled out within three days, from the delivery date shown in the shipping documents. Omcan has no recourse for damaged products that were shipped collect or third party.

Before operating any equipment, always read and familiarize yourself with all operation and safety instructions.

Omcan would like to thank you for purchasing this machine. It's of the utmost importance to save these instructions for future reference. Also save the original box and packaging for shipping the equipment if servicing or returning of the machine is required.

Omcan Fabrication et distribution Compañie Limité et Food Machinery d'Amerique, dba Omcan et Omcan Inc. ne sont pas responsables de tout dommage ou blessure causé du fait que toute personne ait utilisé cet équipement de façon irrégulière. Le produit ne doit être exploité que par quelqu'un de plus de 18 ans, saine d'esprit, et pas sous l'influence d'une drogue ou d'acohol, qui a été formé pour utiliser cette machine correctement, et est vêtu de vêtements de sécurité approprié. Toute modification de la machine annule toute garantie, et peut causer un préjudice à des personnes utilisant la machine ou des personnes à proximité de la machine pendant son fonctionnement.

VÉRIFIEZ LE COLIS DÈS RÉCEPTION

Dès réception d'une expédition d'Omcan veuillez inspecter pour dommages externes. Si aucun dommage n'est visible sur l'emballage externe, ouvrez le carton afin de s'assurer que tous les éléments commandés sont dans la boîte, et il n'y a aucun dommage dissimulé à la machine. Si le colis n'a subi aucune mauvaises manipulations, de bosses ou de dommages (visible ou cachée), notez-le sur le bond de livraison avant d'accepter la livraison et contactez Omcan dans les 24 heures qui suivent, pour que nous puissions engager une réclamation auprès du transporteur. Un rapport détaillé sur l'étendue des dommages causés à la machine doit être rempli dans un délai de trois jours, à compter de la date de livraison indiquée dans les documents d'expédition. Omcan n'a aucun droit de recours pour les produits endommagés qui ont été expédiées ou cueilli par un tiers transporteur.

General Information

Avant d'utiliser n'importe quel équipement, toujours lire et vous familiariser avec toutes les opérations et les consignes de sécurité.

Omcan voudrais vous remercier d'avoir choisi cette machine. Il est primordial de conserver ces instructions pour une référence ultérieure. Également conservez la boîte originale et l'emballage pour l'expédition de l'équipement si l'entretien ou le retour de la machine est nécessaire.

Omcan Empresa De Fabricacion Y Distribucion Inc. Y Maquinaria De Alimentos De America, Inc. dba Omcan y Omcan Inc. no son responsables de ningun daño o perjuicio causado por cualquier persona inadecuada o el uso descuidado de este equipo. El producto solo podra ser operado por una persona mayor de 18 años, en su sano juicio y no bajo alguna influencia de droga o alcohol, y que este ha sido entrenado en el correcto funcionamiento de esta máquina, y ésta usando ropa apropiada y autorizada. Cualquier modificación a la máquina anula la garantía y puede causar daños a las personas usando la máquina mientras esta en el funcionamiento.

REVISE EL PAQUETE A SU LLEGADA

Tras la recepcion de un envio Omcan favor inspeccionar daños externos. Si no hay daños evidentes en el empaque exterior, Habra el carton para asegurarse que todos los articulos solicitados estén dentro de la caja y no encuentre daños ocultos en la máquina. Si el paquete ha sufrido un manejo de poco cuidado, golpes o daños (visible o oculto) por favor anote en la factura antes de aceptar la entrega y contacte Omcan dentro de las 24 horas, de modo que podamos iniciar una reclamación con la compañía. Un informe detallado sobre los daños causados a la máquina debe ser llenado en el plazo de tres días, desde la fecha de entrega que se muestra en los documentos de envío. Omcan no tiene ningun recurso por productos dañados que se enviaron a recoger por terceros.

Antes de utilizar cualquier equipo, siempre leer y familiarizarse con todas las instrucciones de operación y seguridad.

Omcan quisiera darles las gracias por la compra de esta máquina. Es de la máxima importancia para guardar estas instrucciones para referencias en el futuro. También guarde la caja original y el embalaje para envío del equipo si el mantenimiento o la devolución de la máquina es necesaria.

Safety and Warranty

The following clearly specifies the definitions meaning, which will be used in the present document.

DANGER

It shows the danger presence for who works on the machine and for who is the vicinity, so the indicated activity must be performed in accordance with the actual accident prevention standards and with the indications showed in the present manual.

Safety and Warranty

PRECAUTION

It shows a warning on useful information and/or further recommendations and/or shrewdness about the actual operation.

ATTENTION

It shows an operation to perform with attention to avoid damage to the machine.

The peeler is designed to peel potatoes using the peeler abrasive dish.

The machine is constituted from an electric motor inserted inside the STAINLESS steel hull, where the motor shaft is connected through appropriate transmission belt to the rotation pivot where the cleaning dish is inserted manually.

In its basic configuration the machine is constituted from:

1. STAINLESS steel hull where the feed products to treat are inserted.
The STAINLESS basin internal surface where the product to treat is introduced, is covered with a removable abrasive length of material and washable manually.
2. Abrasive dish to insert manually in the rotation pivot, used to peel the potatoes.
3. Transparent superior lid that allows observing the working progress, this lid is equipped of handle and safety sensor that surveys the closure position.
4. Lateral unloading door that allows the product unloading at the working end. The door is equipped with safety sensor that surveys the closure position.
5. Drawer in STAINLESS steel sheet metal inserted manually under the bottom of the hull, on which the water and the product dresses are unloaded. Inside the drilled drawer 1 filter in STAINLESS steel sheet metal is placed for the dresses harvest. In the drawer inferior zone a collector for the water falling is present on well with battery.
6. Plastic cover fastened laterally to the carcass and sealed with appropriate gasket, containing the electric material and in its superior zone the control panel is present for the machine functioning.

All direct contact materials with the feed product are in accordance with the actual hygienic standards for foods. The machine is provided with the rating plate on which the appropriate data is shown.

NORMAL USE, IMPROPER USE, NOT CORRECT USE OR FORBIDDEN

The machine described in the present instructions manual for the use is foreseen to be driven from an only operator skilled and prepared on residual risks, but with the competence, in safety matter, of maintenance employees. The operator should have at least the minimum age foreseen from the social laws about the work and having had the necessary technical training at least from a more expert operator that had him preliminarily trained for the correct use of the machine.

PRECAUTION

In its NORMAL USE, and reasonably foreseeable, the machine can be used only to peel potatoes with the cover and doors closed and blocked.

Safety and Warranty

ATTENTION

The machine must not be used IN IMPROPER WAY; in particular:

1. It must not be used for domestic uses.
2. It must not functioned with parameters different from those showed in the technical characteristics table.
3. For every use of the machine with modalities different from those showed in the present manual, the manufacturer declines every responsibility.
4. The user is responsible of the damages resulting from the lacked exercise conditions observance in accordance with the agreed technical specifications and order confirmation.
5. Introduce only the listed food products.
6. Not tamper or damage intentionally nor remove or hide the labels.

ATTENTION

The machine must not be used IN NOT CORRECT WAY or FORBIDDEN so some damages or injuries could be caused for the operator; in particular:

1. It is forbidden to move the machine when it is connected to the electric feeding.
2. It is forbidden to draw the electric feeding cable or the machine to disconnect the feeding.
3. It is forbidden to draw the electric feeding cable or the drinking water flexible pipe or draw the superior cover or the lateral handle to move the machine.
4. It is forbidden to put weights on the machine or on the electric feeding cable, on the drinking water flexible pipe or on the discharging pipe.
5. It is forbidden to put the electric feeding cable on sharp parts or with burn danger.
6. It is forbidden the machine use with the damaged and not integer electric feeding cable or with the control devices.
7. It is forbidden the machine use with the drinking water flexible pipe, with the discharging pipe or with the superior cover packing or the lateral door damaged and not integer and however with the evident presence of water losses from any machine component.
8. It is forbidden to leave the machine off with the electric feeding cable connected with the feeding plug or with the drinking water flexible pipe connected to the feeding plant.
9. It is forbidden to leave the machine charged unguarded switched off or in function.
10. It is forbidden to insert any type of object inside the motor ventilation cap.
11. It is forbidden the machine functioning without have closet the dresses harvest drawer with inside the filter or without have fastened the pipe for the charge to the lateral connector (if present).
12. It is forbidden to thread any type of object under the machine base or put clothes or other between the machine support stems and the floor.
13. It is forbidden the use of inflammable substances, corrosive or harmful or high pressure water jets for the cleaning.
14. It is forbidden to plunge the machine in water or in other liquids.
15. It is forbidden the not authorized personnel use and with clothes different from that showed for the use.
16. It is forbidden to introduce in the basin or in correspondence of the service mouth, during the dish rotation, the hands or any other part of the body or any other object (for example poles, cutlery, etc...), to remove and to facilitate the food product charge.
17. It is forbidden to maintain the charging door completely open during the dish rotation, to facilitate the food product charge.
18. It is forbidden the functioning with the fixed and moving protection shelters not blocked correctly or removed.

Safety and Warranty

19. It is forbidden the partial removal of the protections and of the danger signals.
20. It is forbidden the functioning without that all the precautions about the residual risks elimination have been adopted on behalf of the user.
21. It is forbidden to smoke or use free flame devices and manipulate incandescent materials, unless some suitable safety measures aren't adopted.
22. It is forbidden to activate or set the control and blockage devices as knobs or similar both during the machine functioning both if you aren't authorized.

PRECAUTION

The user is however responsible of the damages resulting from the lacked observance of the specified normal use conditions. For possible doubts you can enquire at the Authorized Assistance Center.

PRECAUTION

The lacked standards and safety procedures applications can be danger and damage sources. The machine means bound in the use for the respect, on behalf of the final user, of:

1. All rules, of insertion in the environment and of people behavior, fixed from the laws and/or applicable standards; with particular reference to the fixed plant upstream of the supplied machine and for its connection / functioning.
2. All further instructions and use warnings making part of the technical / graphic documentation annexed to the same machine.

ATTENTION

Except where differently specified, the personnel which performs the installation interventions, connection, maintenance, reassembly, and reuse, damages or breakdowns, demolition and dismantling must be a skilled personnel qualified in safety matter and educated on the residual risks, with the competencies, in safety matter, of the maintenance employees.

ENVIRONMENTS, WORKING AND PASSING PLACES

The work environment must answer to the directive 89/654/CEE requirements. In the working area foreign object must not be present. The employer, in the directive 89/391/CEE respect, concerning the measures realization turned to promote the safety and workers health improvement during the work, must provide to eliminate or reduce the showed residual risks as foreseen in the present manual.

WARNINGS ON THE RESIDUAL RISKS

RESIDUAL RISK DUE TO THE FIXED AND MOVING PROTECTION FOR INTERVENTIONS WITHIN THE BASIN

DANGER

For any occasion the operator must not try to open or remove a fixed or moving protection or tamper a safety device. In the phase of equipment, maintenance, dish change and cleaning, and during all further manual operations that happens introducing the hands or other body parts in the machine dangerous areas, a residual risk remains due above all to:

1. Knocks with machine manufacturing parts.

Safety and Warranty

2. Grazing and/or abrasion with machine rough parts.
3. Sharp pain with the sharpened parts.

The operator and the maintenance man must be skilled for the intervention connected to the manual operations with open protections, must be trained on the joined consequent risks and must be authorized from a responsible person and must use adequate individual protection devices, five fingers anti abrasion gloves.

RESIDUAL RISK DUE TO THE DISCHARGING OPERATIONS

DANGER

During the food product discharging operations, the operator must place a bowl in correspondence of the discharge mouth before to open the door. Subsequently, with the superior cover closed and blocked, to facilitate the products leakage with continue action on the control device the operator can activate the dish rotation. In this phase and during the other discharge phases remains a risk due above all to:

1. Food product projection.

The operator must however always place the adequately great bowl and must maintain the lateral discharge door handle lightly opened to convey and direct the food products in the bowl. Besides both the operator both the other people must place laterally and not frontally to the discharge mouth.

RESIDUAL RISK DUE TO THE WATER USE

DANGER

During the functioning the machine is connected to the drinking water plant to allow the treated product washing. The water and the treated food product dross are after fall discharged or from the machine inferior or lateral side. In this phase and during all machine functioning remains a residual risk die above all to:

1. Flooding possibility.
2. Water splashes.

Independently from the discharge position, inferior or lateral, the machine must always be placed above a well with drain for the water harvest. Besides if the machine is equipped with lateral discharge, it is the maintenance man duty to foresee and insert a dress harvest filter coming from the basin and connect the pipe for the discharge to the lateral collector.

1 YEAR PARTS AND LABOR WARRANTY

Within the warranty period, contact Omcan Inc. at 1-800-465-0234 to schedule an Omcan authorized service technician to repair the equipment locally.

Unauthorized maintenance will void the warranty. Warranty covers electrical and part failures, not improper use.

Please see www.omcan.com/warranty.html for complete info.

Safety and Warranty

WARNING:

The packaging components are classified as normal solid urban waste and can therefore be disposed of without difficulty.

In any case, for suitable recycling, we suggest disposing of the products separately (differentiated waste) according to the current norms.

DO NOT DISCARD ANY PACKAGING MATERIALS IN THE ENVIRONMENT!

Technical Specifications

Model	PE-IT-0010	PE-IT-0018
Production/H	661.4 lbs. / 300 kgs.	1102.3 lbs. / 500 kgs.
Cycle Time	90-120 seconds	120-150 seconds
Maximum Volume	22 lbs. / 10 kgs.	39.6 lbs. / 18 kgs.
RPM	320	
Power	0.75 HP / 550W	1.2 HP / 900W
Electrical	115V / 60Hz / 1	
Dimensions	20.9" x 26" x 43.3" 530 x 660 x 1100mm	20.9" x 26" x 47.2" 530 x 660 x 1200mm
Packaging Dimensions	26.4" x 23.6" x 48" 670 x 600 x 1220mm	26.4" x 23.6" x 52" 670 x 600 x 1320mm
Weight	98.1 lbs. / 44.5 kgs.	109.1 lbs. / 49.5 kgs.
Packaging Weight	120.2 lbs. / 54.5 kgs.	131.2 lbs. / 59.5 kgs.
Item Number	44184	44185

Installation

PREPARATION PRELIMINARY OPERATIONS

STABILITY

The machine stability is designed so that, in the foreseen functioning conditions, taking into account of the climatic conditions is such as to allow the use without reversal risk, fall, or inopportune movement. Taking into account of the conformation and its position, the machine results to be intrinsically steady without any fastening needs to the trampling flat. All support feet placed under the base must lay on a solid, uniform and well leveled

Installation

surface.

ELECTRIC FEEDING

The electric feeding connection must be in conformance with the country legislation in which is used. The electric feeding so must be maintained in conformance with the following technical prescriptions:

1. The electric feeding must be always of type and have an intensity corresponding to the specifications indicated in the machine plate. If excessive voltages are applied, some components will be damaged irreparably.
2. A differential device must be foreseen coordinated with the protection circuit, respecting the legislation, the legislative and regulation disposals in force in the installation country.
3. The electric feeding cable outside the machine cover must be made pass in the spaces prepared from You and adequately protected.
4. If present the neutral conductor (N) before feeding the electric equipment, as for you its continuity must be guaranteed (connected and available).
5. Before to feed the electric equipment, as for you must be guaranteed the continuity of the green yellow conductor of the protection equipotential circuit.

DRINKING WATER FEEDING

The drinking water feeding connection must be in conformance with the country pertinent legislation where is used. The feeding must so present the following technical prescriptions:

1. The machine must be connected to a drinking water piping.
2. The flexible pipe must be connected to a tap for the water opening and closure.
3. For the protection against the over pressures, a protection device must be foreseen coordinated with the machine drinking water system, with the aim to respect the legislative and regulation disposal using in the installation country.
4. The connection manifold sizes of the flexible pipe in endowment, the flux pressure and the water temperature are showed in the technical data table. If the pressure is superior to the maximum agreed, a pressure reducer valve must be assembled.
5. After having performed the connection open slowly the tap to verify that the connection is hermetic. Eventually correct the gasket seat and the connector.
6. The drinking water flexible pipe for the feeding must be made pass in the spaces prepared from You and adequately protected.

WATER AND DROSS DISCHARGE

The machine allows alternatively to discharge the water and the product working dross in two ways:

1. With inferior fall: the machine must be simply placed above a drain well having care to verify that the dross drawer discharge hole is aligned with the well.
2. Floor discharge: on such models the lower discharge pipe (not included in the standard supply) has to be connected to a tube inserted into the floor draining grill.

The discharge water from the machine isn't drinking, so it must be conveyed directly towards floor harvest systems.

Installation

ASSEMBLY / DISASSEMBLY

DANGER

The assembly / disassembly operations of any machine part are performed with the stop machine, with the plug disconnected from the socket and with water tap closed, or with the sectioning device in OFF and with the basin completely empty, without nor water nor food products.

LATERAL DISCHARGE COLLECTOR ASSEMBLY

In the case that the machine is equipped with inferior fall water discharge of the cross drawer, the water and cross discharge can be foreseen through the lateral fall discharge collector. The transformation and the intervention can be performed only from the Authorized Assistance Center.

DISH AND ABRASIVE TELO DISASSEMBLY/ASSEMBLY INSIDE THE BASIN

1. Struggle on the handle (1) of the transparent superior cover (2) and lift it up to carry as back as possible.
2. Remove manually possible food products present within the basin (3).
3. Grasp manually and lift the dish (4) within the basin and extract it.
4. In correspondence of the discharge mouth, push manually the abrasive cloth (5) towards inside the basin. After grasp it with both the hands and lift it completely from the basin.

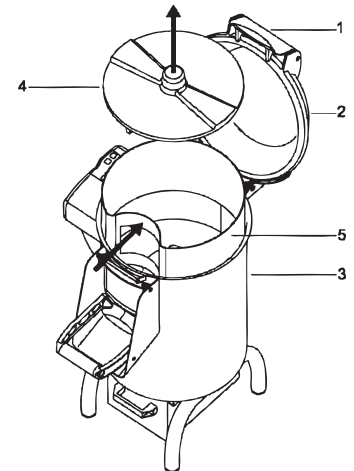

For the assembly repeat on the contrary the above described operations.

DANGER

After having inserted the flat, check the correct bayonet hook in the rotating pivot.

Operation

FUNCTIONING DESCRIPTION

The control devices are designed and manufactured so as much sure and reliable and resistant to the service normal stresses, to the foreseeable strains and to the external agents. Besides they are clearly visible, locatable and marked from a suitable marking. Here follow the main control devices are showed:

Button	Description
On/Off	Button for the general switching on and switching off of the controls panel.
O	Button for the machine stop control.
I	Button for the machine starting control with impulse.
⊕	Button for the maintained action machine starting control with the opened discharge lateral door (if any).

Operation

+	Button for the functioning time increase (of 10 sec in 10 sec) keeping pushed it (of 1 sec in 1 sec).
-	Button for the functioning time decrease (of 10 sec in 10 sec) keeping pushed it (of 1 sec in 1 sec).
	Red Display: Functioning time visualization.

SWITCHING ON / SWITCHING OFF

The impulse switching on and switching off of the controls panel and the display is possible only with a voluntary action on the control device foreseen with this aim: **On/Off button**.

FUNCTIONING TIME

Before the machine starting the functioning time setting is possible only with a voluntary action on the control device foreseen with this aim: **+** button to increase the time, or the **-** button to decrease the time.

STARTING

The machine impulse starting is possible, after the switching on, only with a voluntary action on the control device foreseen for this aim: **I button** for the machine starting control.

STOP

For the stop control of the machine work function, without have a display complete switching off, activate the **O button**.

MAINTAINED ACTION STARTING

The machine maintained action starting is possible only with a voluntary action on the control device foreseen for this aim: **⊕ button**. The maintained action control is used in the 10-18 Kg versions for the product unloading operations. During the button releasing the machine stops.

VOLTAGE LACKING

In case of electric feeding breaking or if the machine is disconnected from the electric net, this last one will be able to be restarted only following the starting function, after the electric feeding back or the reconnection to the electric net.

TRANSPARENT SUPERIOR COVER OPENING AND LATERAL DISCHARGE DOOR

Lifting the superior cover or the lateral discharge door (if any) the machine stops immediately for the safety micro switch functioning. The machine can be restarted only closing and blocking the superior cover and the lateral discharge door and following successively the starting function.

PUT IN FUNCTION

The machine operator can put in function the machine following in order the under reported indications:

1. Close and block the discharge lateral door pushing it towards the machine body and lowering the handle for the block.
2. Introduce manually the food product with the superior transparent cover completely opened, inside the basin. The filling must happen in accordance with the limits established in the machine technical data.

Operation

3. Control positive result of the drinking water injunction nozzle, that must not be clogged.
4. Close and block the superior transparent cover pushing towards the machine body and lowering the handle for the block.
5. Put in the machine lateral zone and switch on the machine and the display, activating with impulse the **On/Off button**. Successively set the functioning time with impulses on the **+ button** to increase the time, or the **- button** to decrease it and start the functioning activating the **I button**.
6. At the end of the set time the machine stops and on the display the last working time appears. If you want to reactivate the functioning follow the indications of the previous point or push the **I button** to repeat the cycle. If on the contrary you want to stop the functioning before the end of the set time, activate with impulse the **O button**.

UNLOADING

The machine operator can perform the basin discharge following in order the showed indications:

1. Put an adequate great bowl in correspondence of the discharge mouth.
 2. Unblock and open the discharge lateral door pull towards up the block handle.
 3. Put laterally and not frontally to the discharge mouth, open lightly the discharge lateral door to convey and make direct the food products in the bowl.
 4. Push with continue action the **⊕ button**, to activate the flat rotation so to facilitate the food product leakage.
- For the food products discharge remained in the basin bottom, it is also possible to open the superior transparent cover and draw manually the food product from the basin superior zone.

SWITCHING OFF

In succession, the switching off must follow what here under indicated:

1. Before the switching off discharge completely the basin content.
2. Stop the machine activating the **On/Off button**.
3. Close the drinking water tap and unscrew the feeding pipe union of the drinking water from the tap.
4. Disconnect the machine plug from the feeding socket.
5. Perform the cleaning interventions.

Maintenance

DANGER

The machine must be turned off and unplugged from the power supply before any maintenance can be performed.

CLEANING

DANGER

It is forbidden to clean by hand the organs and the elements in motion. All cleaning interventions must be started only and exclusively, after having unloaded the machine with the food product in working and having

Maintenance

insulated from the electric feeding source and from external energy.

The machine, the electric equipment and the machine board components must not be ever washed utilizing water, and not in any kind of jets form and quantity; so, without “bucket” nor “rubber” nor “towel”. Don’t put ever directly the machine in the sink or under the tap. The machine hygiene level classification and the associated equipment, for the foreseen use, are 2 (two): machine that, after a hygiene risk evaluation, is in conformance with applicable international standards requirements, but requests a programmed disassembly for the cleaning.

All the surface and the machine parts destined to come in contact with the food product or with the food zones ((basin internal surface, transparent superior cover, discharge lateral door, the flats) and the splashes zones (machine external surface), must be cleaned with the following modalities and order:

1. Discharge all food products inside the basin.
2. Close and block the transparent superior cover and the discharge lateral door and perform a cycle of at least 10 seconds with the connected drinking water but without food products.
3. Unblock and open the cover and the lateral door and remove both the basin bottom flat, both the coating abrasive cloth of the basin internal surface.
4. The easy removal happens lifting the basin surface cloth before from the anterior zone in correspondence of the discharge mouth, after from the other parts.
5. Close and block the cover and the lateral door and perform a cycle of at least 10 seconds with the connected drinking water but without food products.
6. Unthread the steel sheet drawer from the keel bottom and empty the working dross. If the lateral discharge is present, make the same with the filter connected with the discharge pipe.
7. Wash the flat and the abrasive cloth under the drinking water jet.
8. The abrasive plate cannot be washed in the dishwasher.
9. Unblock and open the cover and the lateral door and:
 - Scrape the surfaces from the possible food product residuals (for example with plastic scrapers).
 - Clean all the food zone surfaces and jets zone with a morbid dampened clothes (not draining) with detergent diluted in hot water (also common soap for dishes is good). Don’t soak them. With a towel clean inside the grinding mouth. Use specific products for steel, which must be liquids (not in cream or pastries however abrasive) and above all must not contain chlorine. Against the fat substances the denatured alcohol.
 - Rinse with cleaned hot water and successively dry all food zone surfaces and jets zone with soft clothes that don’t lose coats.
 - The reassembly must happen only after a working requirement, leave the pieces wrapped in a dry soft clothes that don’t lose coats.

PERIODS OF LONG INACTIVITY

During the machine long inactivity periods provide to pass vigorously on all steel surfaces (especially if stainless) a clothes soaked of Vaseline oil so that to spread a protective veil.

THINGS NOT TO DO BEFORE OR DURING THE CLEANING:

- Enter towards the moving elements without to be previously checked of their stop.
- Enter towards the moving elements without have stopped it in safety stop (blockage in zero position of the electric feeding sectioning devices).

Maintenance

PRODUCTS NOT TO USE:

- Compressed air with jets towards the machine.
- A high pressure cleaner or a continue water jet.
- Vapor equipment or water jets in pressure.
- Detergent that contains CHLORINE (also if diluted) or its compounds as: the bleach, the muriatic acid, products to clear the drain, products for the marble cleaning, in general decalcifying, etc. can attack the steel composition, staining and oxidizing it unavoidable. The only above described products fumes can oxidize and in any case corrode the steel.
- Steel wool, brushes or abrasive discs produced with other metals or alloys (ex. Common steel, aluminum, brass, etc...) or tools that have previously cleaned other metals or alloys, that except to scratch the surface.
- Detergents in abrasive dust.
- Fuel, solvents or inflammable and/or corrosive fluids.
- Substances used to clean the silver.

Troubleshooting

TYPE	POTENTIAL CAUSES	Solutions
Net voltage lacking.	General Black out.	Contact the electric energy distributor.
	Fuses or magneto thermals intervention place upstream of the machine feeding line.	After having eliminated the causes that have determined the protection device intervention, restore it. In case of problem persistency contact an electrician technician.

Troubleshooting

Functioning intervention.	Protection device intervention inside the machine.	Contact an electrician technician: after having eliminated the causes that have determined the protection device intervention, restore it. In case of fuses intervention, change them with types of the same model, calibration and intervention curve.
	Unblock and opening of the transparent superior cover or of the discharge lateral door (if any).	Unblocking and opening the cover or the door, the machine stops immediately for the safety micro switches functioning. Close and block the cover and the door handles.
	Cause/s not identifiable.	Contact directly the Authorized Assistance Center.
The machine doesn't function: the flat doesn't rotate.	Feeding voltage lacking.	Check and restore the electric energy.
	Sectioning devices on "O".	Turn the sectioning devices in the position "ON "
	Lacked working time setting.	Set the timer in the controls panel.
	Intervened fuses or not functioning magneto thermals.	Change the intervened fuses, check the magneto thermal switches condition.
	Lacked buttons functioning.	Check the buttons efficiency and eventually contact directly the Authorized Assistance Centre.
	Damaged micro switches.	Contact directly the Authorized Assistance Centre.
	Slow drive belt determines also noise or creaking emission.	Contact directly the Authorized Assistance Centre.
The potatoes don't peel correctly.	Worn flat surface.	Contact directly the Authorized Assistance Centre for the change.
	Abrasive cloth surface inside the worn basin.	Contact directly the Authorized Assistance Centre for the change.

Troubleshooting

Drinking water absence inside the basin during the functioning.	Drinking water flexible pipe not connected.	Connect the drinking water flexible pipe, screwing the piping union to the tap male joint.
	Tap closed.	Rotate the superior part in clockwise for the drinking water flow.
	Water emission nozzle inside the obstructed basin.	Perform the nozzle holes cleaning as showed, with the switched off machine and insulated from the external feeding sources.
	Damage in the plant inside the machine.	Contact directly the Authorized Assistance Centre
Excessive water presence inside the basin that doesn't discharge or splash in the machine inferior zone.	Dross separation filter obstructed.	Clean it.
	Drawer in steel in the body inferior zone mal inserted.	Insert on the drawer bottom so that the basin discharge happens completely inside the drawer.
	Presence of losses from the lateral discharge pipe union	Discharge pipe not inserted correctly or not blocked with strip.
Presence of evident water drops or wire drawings in the machine superior and/or inferior surface.	Drinking water flexible pipe unions not screwed correctly to the tap or to the machine.	Switch off the machine, insulate it from the external feeding sources and tighten the pipe unions to the relative male joints. In the case the pipe union thread is stripped or the gaskets are absent, contact directly the Authorized Assistance Centre.
	Worn transparent superior cover gasket.	Contact directly the Authorized Assistance Centre for the change.
	Worn discharge inferior door gasket.	Contact directly the Authorized Assistance Centre for the change.
	Water losses presence in the plastic wrapping perimeter zone.	Contact directly the Authorized Assistance Centre.
	Water splashes coming from the flexible pipe or wire drawings.	Flexible pipe with holes or cracks, contact directly the Authorized Assistance Centre for the change. Change the pipe at least every 3 years.

Troubleshooting

REFERENCE

Item Number	Model Number	Description	Manufacturer Model Number
44184	PE-IT-0010	Potato Peeler 22 lb./10 kg. with Microswitch and Floor Water Discharge 0.75 HP/550 W 115V/60/1 QPS	FP100
44185	PE-IT-0018	Potato Peeler 39.6 lb./18 kg. with Microswitch and Floor Water Discharge 1.2 HP/900 W 115V/60/1 QPS	FP102

Parts Breakdown

Model PE-IT-0010 44184

Model PE-IT-0018 44185

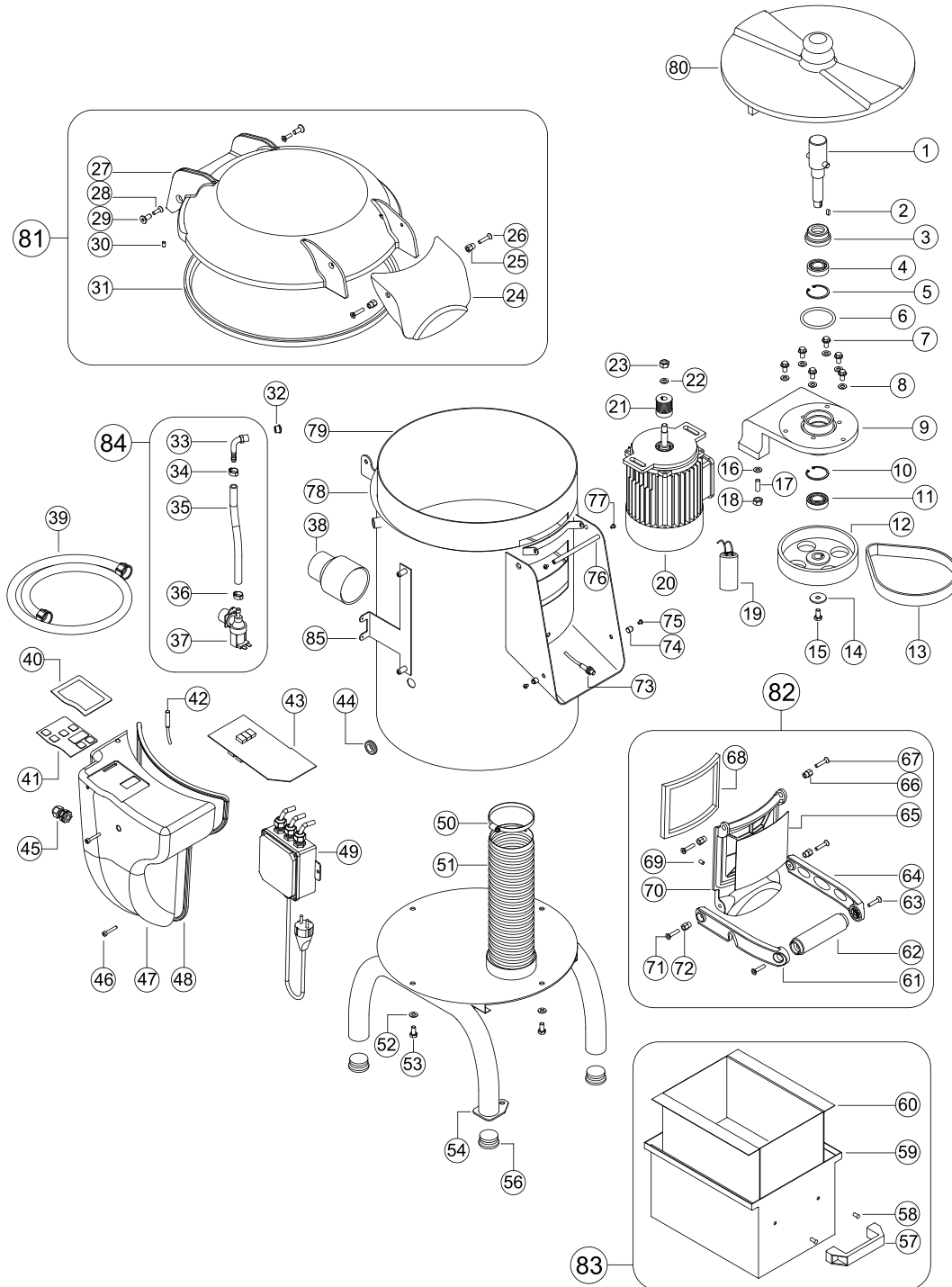

Parts Breakdown

Model PE-IT-0010 44184

Item No.	Description	Position	Item No.	Description	Position	Item No.	Description	Position
64598	Pin for FP100	1	64625	INOX Screw Cover (2 pcs.) for FP100	29	64651	Drawer Handle for FP100	57
64599	5x5x15 Key for FP100	2	64626	Magnet 6x20 Cover for FP100	30	64652	Waste Drawer for FP100	59
64600	Mechanical Seal D.25 for FP100	3	64627	Cover Gasket for FP100	31	64653	Waste Filter for FP100	60
64601	Bearing 6004 2RS for FP100	4,11	64628	Nozzle of Water for FP100	32	64654	Left Arm Handle for FP100	61
64602	Seeger from 42 for FP100	5,10	64629	Resca for Water Jet Nozzle for FP100	33	64656	Handle Grip for FP100	62
64603	Ring OR 6225 for FP100	6	64630	Strap 13/15 for FP100	34	64657	M6x25 Stainless Steel Screw Head (2 pcs.) for FP100	63
64604	M8x16 Flanged Screw (6 pcs.) for FP100	7	64631	Water Tube 8x22 for FP100	35	64658	Right Arm Handle for FP100	64
64605	Flange Seal Gasket (6 pcs.) for FP100	8	64632	Strap 15/18 for FP100	36	64659	Door Sticker for FP100	65
64606	Motor Flange for FP100	9	64633	Solenoid Valve for FP100	37	64660	Door Gasket for FP100	68
64607	Conduit Pulley for FP100	12	64634	80/50 Discharge Reduction for FP100	38	64661	Magnet 6x15 Door for FP100	69
64608	Belt J12 for FP100	13	64635	Water Load Tube for FP100	39	64662	Door for FP100	70
15364	Washer 8x32x2 for FP100	14	64636	Keyboard Cover for FP100	40	64663	Micro Magnetic Door for FP100	73
15440	Screw 8x25 for FP100	15	64637	Digital Keypad for FP100	41	64664	Stainless Steel Bush (2 pcs.) for FP100	74
70181	Washer 8x16x1,5 (4 pcs.) for FP100	16	64638	Micro Magnetic Cover for FP100	42	64665	Screw 6x8 INOX Button (2 pcs.) for FP100	75
64610	Stainless Grain M8x40 (2 pcs.) for FP100	17	64639	Electronic Control Board for FP100	43	64666	Cover Handle Bar for FP100	76
64611	Nut M8 (2 pcs.) for FP100	18	64640	Rubber Handle 20mm for FP100	44	64667	Screw 5x8 INOX (2 pcs.) for FP100	77
64612	20 uF Capacitor for FP100	19	64641	Cable Gland PG13.5 for FP100	45	64668	Stainless Steel for FP100	78
64614	Complete Motor V.110/60Hz for FP100	20	15372	Screw 5x25 (4pcs.) for FP100	46	64670	Abrasive Canvas for FP100	79
64616	Motor Pulley for FP100	21	64642	Electric Box for FP100	47	64672	Pelapated Abrasive Plate for FP100	80
64617	Washer 10x20x2 for FP100	22	64643	Electric Box Gasket for FP100	48	64673	Transparent Cover Complete for FP100	81
64618	Nut M10 for FP100	23	64644	Power Board B.T. V.110/60Hz for FP100	49	64674	Stainless Steel Cover Complete for FP100	81
64619	Upper Cover Handle for FP100	24	64645	Cable Tie 80/100 for FP100	50	64675	Complete Door for FP100	82
64620	Special Stainless Nut M6 (2 pcs.) for FP100	25,66,72	64646	80mm Exhaust Pipe for FP100	51	64676	Drawer Complete for FP100	83
64621	Stainless Steel Screw M6x14 (2 pcs.) for FP100	26,67	64647	8x16x1,5 INOX Washer (4 pcs.) for FP100	52	64677	Electrovalve Kit Complete for FP100	84
64622	Transparent Cover for FP100	27	64648	Screw 8x18 INOX (4 pcs.) for FP100	53	64678	Bracket and Electrical Panel and No. 2 Bushings for FP100	85
64623	Stainless Steel Cover for FP100	27	64649	Bottom C / Gambe INOX for FP100	54			
64624	Screw 6x8 INOX T.E. (2 pcs.) for FP100	28,58	64650	Foot (4 pcs.) for FP100	56			

Parts Breakdown

Model PE-IT-0018 44185

Item No.	Description	Position	Item No.	Description	Position	Item No.	Description	Position
64598	Pin for FP102	1	64625	INOX Screw Cover (2 pcs.) for FP102	29	64651	Drawer Handle for FP102	57
64599	5x5x15 Key for FP102	2	64626	Magnet 6x20 Cover for FP102	30	64652	Waste Drawer for FP102	59
64600	Mechanical Seal D.25 for FP102	3	64627	Cover Gasket for FP102	31	64653	Waste Filter for FP102	60
64601	Bearing 6004 2RS for FP102	4/11	64628	Nozzle of Water for FP102	32	64654	Left Arm Handle for FP102	61
64602	Seeger from 42 for FP102	5/10	64629	Resca for Water Jet Nozzle for FP102	33	64656	Handle Grip for FP102	62
64603	Ring OR 6225 for FP102	6	64630	Strap 13/15 for FP102	34	64657	M6x25 Stainless Steel Screw Head (2 pcs.) for FP102	63
64604	M8x16 Flanged Screw (6 pcs.) for FP102	7	64631	Water Tube 8x22 for FP102	35	64658	Right Arm Handle for FP102	64
64605	Flange Seal Gasket (6 pcs.) for FP102	8	64632	Strap 15/18 for FP102	36	64659	Door Sticker for FP102	65
64606	Motor Flange for FP102	9	64633	Solenoid Valve for FP102	37	64660	Door Gasket for FP102	68
64607	Conduit Pulley for FP102	12	64634	80/50 Discharge Reduction for FP102	38	64661	Magnet 6x15 Door for FP102	69
64608	Belt J12 for FP102	13	64635	Water Load Tube for FP102	39	64662	Door for FP102	70
15364	Washer 8x32x2 for FP102	14	64636	Keyboard Cover for FP102	40	64663	Micro Magnetic Door for FP102	73
15440	Screw 8x25 for FP102	15	64637	Digital Keypad for FP102	41	64664	Stainless Steel Bush (2 pcs.) for FP102	74
70181	Washer 8x16x1,5 (4 pcs.) for FP102	16	64638	Micro Magnetic Cover for FP102	42	64665	Screw 6x8 INOX Button (2 pcs.) for FP102	75
64609	Stainless Grain M8x35 (2 pcs.) for FP102	17	64639	Electronic Control Board for FP102	43	64666	Cover Handle Bar for FP102	76
64611	Nut M8 (2 pcs.) for FP102	18	64640	Rubber Handle 20mm for FP102	44	64667	Screw 5x8 INOX (2 pcs.) for FP102	77
64613	50 uF Capacitor for FP102	19	64641	Cable Gland PG13.5 for FP102	45	64669	Stainless Steel for FP102	78
64615	Complete Motor V.110/60Hz for FP102	20	15372	Screw 5x25 (4 pcs.) for FP102	46	64671	Abrasive Canvas for FP102	79
64616	Motor Pulley for FP102	21	64642	Electric Box for FP102	47	64672	Pelapated Abrasive Plate for FP102	80
64617	Washer 10x20x2 for FP102	22	64643	Electric Box Gasket for FP102	48	64673	Transparent Cover Complete for FP102	81
64618	Nut M10 for FP102	23	64644	Power Board B.T. V.110/60Hz for FP102	49	64674	Stainless Steel Cover Complete for FP102	81
64619	Upper Cover Handle for FP102	24	64645	Cable Tie 80/100 for FP102	50	64675	Complete Door for FP102	82
64620	Special Stainless Nut M6 (2 pcs.) for FP102	25,66,72	64646	80mm Exhaust Pipe for FP102	51	64676	Drawer Complete for FP102	83
64621	Stainless Steel Screw M6x14 (2 pcs.) for FP102	26/67	64647	8x16x1,5 INOX Washer (4 pcs.) for FP102	52	64677	Electrovalve Kit Complete for FP102	84
64622	Transparent Cover for FP102	27	64648	Screw 8x18 INOX (4 pcs.) for FP102	53	64678	Bracket and Electrical Panel and No. 2 Bushings for FP102	85
64623	Stainless Steel Cover for FP102	27	64649	Bottom C / Gambe INOX for FP102	54			
64624	Screw 6x8 INOX T.E. (2 pcs.) for FP102	28/58	64650	Foot (4 pcs.) for FP102	56			

Electrical Schematics

Model PE-IT-0010 44184

Model PE-IT-0018 44185

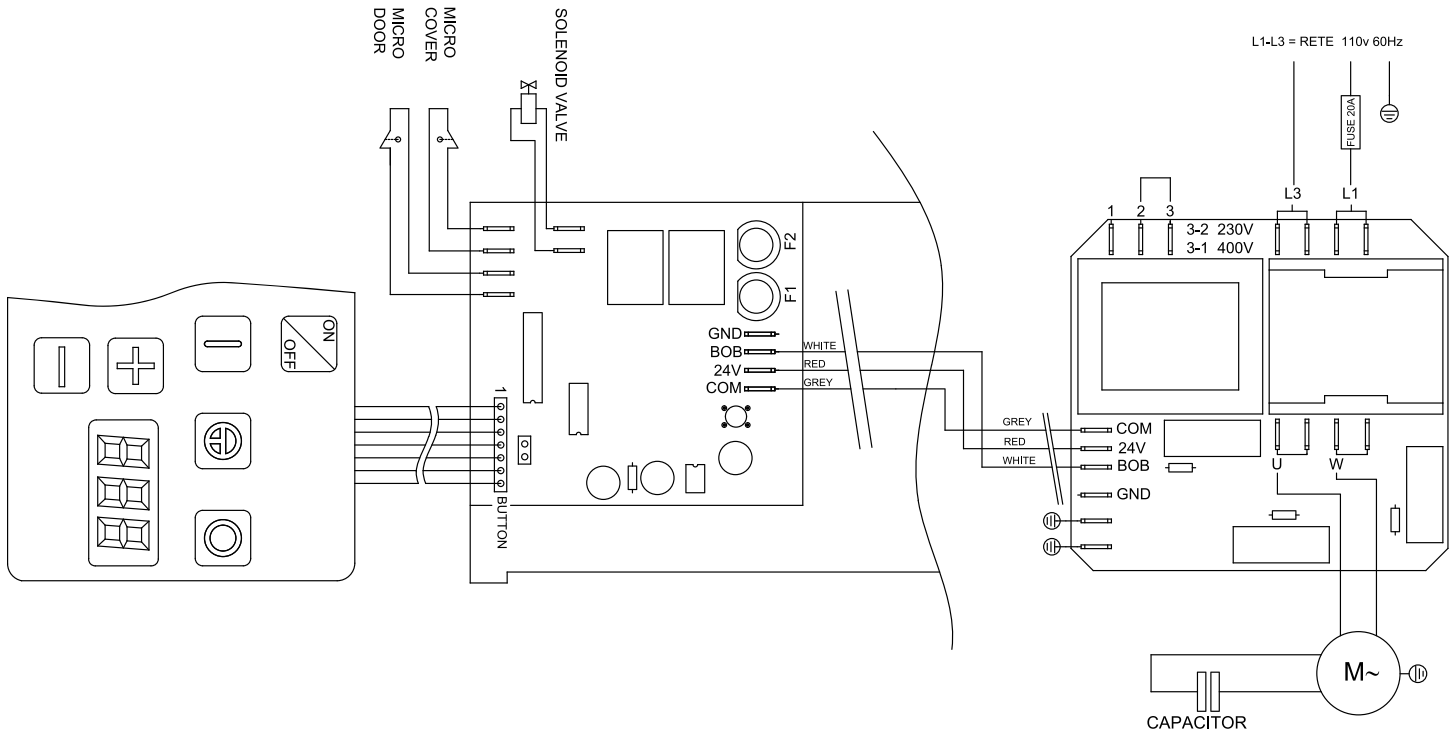



Warranty Registration

Thank you for purchasing an Omcan product. To register your warranty for this product, complete the information below, tear off the card at the perforation and then send to the address specified below. You can also register online by visiting:

Merci d'avoir acheté un produit Omcan. Pour enregistrer votre garantie pour ce produit, complétez les informations ci-dessous, détachez la carte au niveau de la perforation, puis l'envoyer à l'adresse spécifiée ci-dessous. Vous pouvez également vous inscrire en ligne en visitant:

Gracias por comprar un producto Omcan usted. Para registrar su garantía para este producto, complete la información a continuación, cortar la tarjeta en la perforación y luego enviarlo a la dirección indicada a continuación. También puede registrarse en línea en:

www.omcan.com/warrantyregistration.html

For mailing in Canada

Pour postale au Canada

Por correo en Canadá

OMCAN

PRODUCT WARRANTY REGISTRATION

3115 Pepper Mill Court,

Mississauga, Ontario

Canada, L5L 4X5

For mailing in the US

Pour diffusion aux États-Unis

Por correo en los EE.UU.

OMCAN

PRODUCT WARRANTY REGISTRATION

4450 Witmer Industrial Estates, Unit 4,

Niagara Falls, New York

USA, 14305

or email to: service@omcan.com



Purchaser's Information

Name: _____

Address: _____

City: _____ Province or State: _____ Postal or Zip: _____

Country: _____

Dealer from which Purchased: _____

Dealer City: _____ Dealer Province or State: _____

Invoice: _____

Model Name: _____ Model Number: _____

Machine Description: _____

Date of Purchase (MM/DD/YYYY): _____

Would you like to extend the warranty? Yes No

Company Name: _____

Telephone: _____

Email Address: _____

Type of Company:

Restaurant Bakery Deli

Butcher Supermarket Caterer

Institution (*specify*): _____

Other (*specify*): _____

Serial Number: _____

Date of Installation (MM/DD/YYYY): _____

Thank you for choosing Omcan | Merci d'avoir choisi Omcan | Gracias por elegir Omcan



Since 1951 Omcan has grown to become a leading distributor of equipment and supplies to the North American food service industry. Our success over these many years can be attributed to our commitment to strengthen and develop new and existing relationships with our valued customers and manufacturers. Today with partners in North America, Europe, Asia and South America, we continually work to improve and grow the company. We strive to offer customers exceptional value through our qualified local sales and service representatives who provide convenient access to over 3,500 globally sourced products.

Depuis 1951 Omcan a grandi pour devenir un des “leaders” de la distribution des équipements et matériel pour l’industrie des services alimentaires en Amérique du Nord. Notre succès au cours de ces nombreuses années peut être attribué à notre engagement à renforcer et à développer de nouvelles et existantes relations avec nos clients et les fabricants de valeur. Aujourd’hui avec des partenaires en Amérique du Nord, Europe, Asie et Amérique du Sud, nous travaillons continuellement à améliorer et développer l’entreprise. Nous nous efforçons d’offrir à nos clients une valeur exceptionnelle grâce à nos ventes locales qualifiées et des représentants de service qui offrent un accès facile à plus de 3500 produits provenant du monde entier.

Desde 1951 Omcan ha crecido hasta convertirse en un líder en la distribución de equipos y suministros de alimentos en América del Norte industria de servicios. Nuestro éxito en estos años se puede atribuir a nuestro compromiso de fortalecer y desarrollar nuevas relaciones existentes con nuestros valiosos clientes y fabricantes. Hoy con socios de América del Norte, Europa, Asia y América del Sur, que trabajan continuamente para mejorar y crecer la empresa. Nos esforzamos por ofrecer a nuestros clientes valor excepcional a través de nuestro local de ventas y representantes de los servicios que proporcionan un fácil acceso a más de 3,500 productos con origen a nivel mundial.

