



**Pizza Ovens**  
Models PE-IT-0005, 0010  
Items 40633, 40634  
**Instruction Manual**



**STOP**  
**DO NOT RETURN**  
**THIS PRODUCT TO THE STORE**

For questions or assistance with this product call OMCAN Toll Free: 1 800 465 0234 Customer Service or visit the Support section of [www.omcan.com](http://www.omcan.com)

*Revised - 03/27/2019*



Toll Free: 1-800-465-0234  
Fax: 905-607-0234  
Email: [service@omcan.com](mailto:service@omcan.com)  
[www.omcan.com](http://www.omcan.com)



# ***Table of Contents***

Model PE-IT-0005 / Model PE-IT-0010

---

<b>Section</b>	<b>Page</b>
General Information -----	3 - 4
Safety and Warranty -----	4 - 6
Technical Specifications -----	6
Installation -----	6 - 8
Operation -----	9 - 10
Maintenance -----	10 - 11
Troubleshooting -----	11 - 12
Parts Breakdown -----	13 - 16
Electrical Schematics -----	17
Notes -----	18
Warranty Registration -----	19



# General Information

---

Omcan Manufacturing and Distributing Company Inc., Food Machinery of America, Inc. dba Omcan and Omcan Inc. are not responsible for any harm or injury caused due to any person's improper or negligent use of this equipment. The product shall only be operated by someone over the age of 18, of sound mind, and not under the influence of any drugs or alcohol, who has been trained in the correct operation of this machine, and is wearing authorized, proper safety clothing. Any modification to the machine voids any warranty, and may cause harm to individuals using the machine or in the vicinity of the machine while in operation.

## CHECK PACKAGE UPON ARRIVAL

Upon receipt of an Omcan shipment please inspect for external damage. If no damage is evident on the external packaging, open carton to ensure all ordered items are within the box, and there is no concealed damage to the machine. If the package has suffered rough handling, bumps or damage (visible or concealed), please note it on the bill of lading before accepting the delivery and contact Omcan within 24 hours, so we may initiate a claim with the carrier. A detailed report on the extent of the damage caused to the machine must be filled out within three days, from the delivery date shown in the shipping documents. Omcan has no recourse for damaged products that were shipped collect or third party.

**Before operating any equipment, always read and familiarize yourself with all operation and safety instructions.**

Omcan would like to thank you for purchasing this machine. It's of the utmost importance to save these instructions for future reference. Also save the original box and packaging for shipping the equipment if servicing or returning of the machine is required.

---

Omcan Fabrication et distribution Compañie Limité et Food Machinery d'Amérique, dba Omcan et Omcan Inc. ne sont pas responsables de tout dommage ou blessure causé du fait que toute personne ait utilisé cet équipement de façon irrégulière. Le produit ne doit être exploité que par quelqu'un de plus de 18 ans, saine d'esprit, et pas sous l'influence d'une drogue ou d'alcool, qui a été formé pour utiliser cette machine correctement, et est vêtu de vêtements de sécurité approprié. Toute modification de la machine annule toute garantie, et peut causer un préjudice à des personnes utilisant la machine ou des personnes à proximité de la machine pendant son fonctionnement.

## VÉRIFIEZ LE COLIS DÈS RÉCEPTION

Dès réception d'une expédition d'Omcan veuillez inspecter pour dommages externes. Si aucun dommage n'est visible sur l'emballage externe, ouvrez le carton afin de s'assurer que tous les éléments commandés sont dans la boîte, et il n'y a aucun dommage dissimulé à la machine. Si le colis n'a subi aucune mauvaises manipulations, de bosses ou de dommages (visible ou cachée), notez-le sur le bond de livraison avant d'accepter la livraison et contactez Omcan dans les 24 heures qui suivent, pour que nous puissions engager une réclamation auprès du transporteur. Un rapport détaillé sur l'étendue des dommages causés à la machine doit être rempli dans un délai de trois jours, à compter de la date de livraison indiquée dans les documents d'expédition. Omcan n'a aucun droit de recours pour les produits endommagés qui ont été expédiés ou cueilli par un tiers transporteur.

# General Information

---

Avant d'utiliser n'importe quel équipement, toujours lire et vous familiariser avec toutes les opérations et les consignes de sécurité.

Omcan voudrais vous remercier d'avoir choisi cette machine. Il est primordial de conserver ces instructions pour une référence ultérieure. Également conservez la boîte originale et l'emballage pour l'expédition de l'équipement si l'entretien ou le retour de la machine est nécessaire.

---

Omcan Empresa De Fabricacion Y Distribucion Inc. Y Maquinaria De Alimentos De America, Inc. dba Omcan y Omcan Inc. no son responsables de ningun daño o perjuicio causado por cualquier persona inadecuada o el uso descuidado de este equipo. El producto solo podra ser operado por una persona mayor de 18 años, en su sano juicio y no bajo alguna influencia de droga o alcohol, y que este ha sido entrenado en el correcto funcionamiento de esta máquina, y ésta usando ropa apropiada y autorizada. Cualquier modificación a la máquina anula la garantía y puede causar daños a las personas usando la máquina mientras esta en el funcionamiento.

## REVISE EL PAQUETE A SU LLEGADA

Tras la recepcion de un envio Omcan favor inspeccionar daños externos. Si no hay daños evidentes en el empaque exterior, Habra el carton para asegurarse que todos los articulos solicitados estén dentro de la caja y no encuentre daños ocultos en la máquina. Si el paquete ha sufrido un manejo de poco cuidado, golpes o daños (visible o oculto) por favor anote en la factura antes de aceptar la entrega y contacte Omcan dentro de las 24 horas, de modo que podamos iniciar una reclamación con la compañía. Un informe detallado sobre los daños causados a la máquina debe ser llenado en el plazo de tres días, desde la fecha de entrega que se muestra en los documentos de envío. Omcan no tiene ningun recurso por productos dañados que se enviaron a recoger por terceros.

Antes de utilizar cualquier equipo, siempre lea y familiarizarse con todas las instrucciones de funcionamiento y seguridad.

Omcan le gustaría darle las gracias por la compra de esta máquina. Es de la mayor importancia para salvar estas instrucciones para futuras consultas. Además, guarda la caja original y el embalaje para el envío del equipo si servicio técnico o devolución de la máquina que se requiere.

# Safety and Warranty

---

## WARNINGS FOR THE INSTALLER

Check that the location of the oven is in compliance with local, and national regulations.

- Adhere to the instructions in this manual.
- Do not execute electrical connections using temporary or uninsulated cables.
- Check that the ground connection of the electrical system is functioning properly.
- Always use individual safety devices and other means of protection in compliance with the law.

# *Safety and Warranty*

---

## **WARNING FOR THE USER**

The conditions in the surrounding area where the machine will be installed must have the following characteristics:

- The area must be dry.
- The area must have water and heat sources at an adequate distance.
- Ventilation and lighting must be suitable and comply with the hygiene and safety standards foreseen by current laws.
- The floor must be flat and compact to facilitate thorough cleaning.
- There must be no obstacles of any kind in the immediate vicinity of the machine that could effect the machine's normal ventilation.

In addition, the user must:

- Make certain to keep children away from the machine when it is operating.
- Adhere to the instructions in this manual.
- Not remove or tamper with the safety devices on the machine.
- Always pay careful attention to the work at hand and not use the machine when in a distracted state.
- Perform all operations with maximum safety and calm.
- Respect the instructions and warnings displayed on the machine labels.

The labels are accident prevention devices, and therefore must always be perfectly legible. If these should be damaged and illegible, it is mandatory to replace them by requesting replacements from the Manufacturer.

- At the end of each working shift, before cleaning, maintenance or transfer operations, disconnect electrical power.

## **WARNINGS FOR THE MAINTENANCE OPERATOR**

Observe the instructions indicated in this manual.

- Always use individual safety devices and other protection means.
- Before starting any maintenance operations, make sure that the oven, it was used, is cooled down.
- If any of the safety devices is worn or faulty, the oven is also considered faulty and not to be used.
- Disconnect electrical power before intervening on electrical or electronic parts and connectors.

## **1 YEAR PARTS AND LABOUR BENCH WARRANTY**

**Within the warranty period, contact Omcan Inc. at 1-800-465-0234 to schedule a drop off to either an Omcan authorized service depot in the area, or to an Omcan Service warehouse to repair the equipment.**

**Unauthorized maintenance will void the warranty. Warranty covers electrical and part failures, not improper use.**

**Please see <https://omcan.com/disclaimer> for complete info.**

# Safety and Warranty

---

## WARNING:

The packaging components are classified as normal solid urban waste and can therefore be disposed of without difficulty.

In any case, for suitable recycling, we suggest disposing of the products separately (differentiated waste) according to the current norms.

**DO NOT DISCARD ANY PACKAGING MATERIALS IN THE ENVIRONMENT!**

# Technical Specifications

---

Model	PE-IT-0005	PE-IT-0010
Maximum Temperature	450°C / 842°F	
Electrical	220V/60/1	
Power	2.2 kW	3.6 kW
Volume	5.3 Cu. Ft.	9.5 Cu. Ft.
Chamber Dimensions	13.75" x 13.75" x 3.3" 349 x 349 x 84mm	19.6" x 19.6" x 5.11" 498 x 498 x 130mm
External Dimensions	22.8" x 19.6" x 11.3" 579 x 498 x 287mm	29.3" x 26" x 12.6" 744 x 660 x 320mm
Net Weight	66 lbs. / 30 kgs.	77 lbs. / 35 kgs.
Gross Weight	77 lbs. / 35 kgs.	88 lbs. / 40 kgs.
Item Number	40633	40634

# Installation

---

Responsibility for operations executed in the location where the machine is installed is, and remains, of the user. The user is also responsible for execution of controls related to the installation of the machine.

The user must adhere to all local and national safety regulations.

The equipment must be installed on floors with adequate load capacity.

The assembly and disassembly instructions for the oven are reserved for specialized technicians.

It is always recommended that users contact our assistance service for technical requests.

If other technicians intervene, it is recommended to make certain of their skills.

Prior to starting machine assembly or disassembly, the installer must adhere to safety precautions in compliance with the law, and in particular must:

- Not operate in adverse conditions.
- Operate in perfect psycho/physical conditions and must check that the individual accident prevention devices are perfectly functional.
- Wear accident prevention gloves.
- Wear accident prevention footwear.
- Use tools that are electrically insulated.
- Make sure that the area used for assembly and disassembly is free of any obstacles.

## OVEN INSTALLATION LOCATION

The following figure illustrates the minimum distances that must be respected when positioning the machine to facilitate use, cleaning and maintenance of the oven.

The minimum distance that must be respected between the oven and surrounding walls or other machines must be approximately 7.9" / 20 cm.

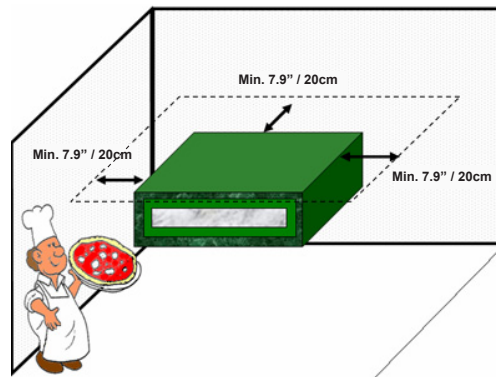

Installation must be executed by qualified personnel in compliance with local and national regulations.

## OVEN POSITIONING

Ensure that the oven is put on a stand with the suitable carrying capacity and that it is flat. After unpacking the oven from its packing, position it in prepared location, taking into account the minimum distances. Remove possible protections in polystyrene and take off the protecting film (F) avoid use of tools which can damage the surfaces.

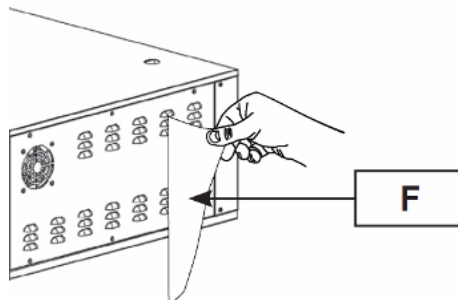

# Installation

---

## EQUIPMENT HOOK-UP

### Electrical connection

The oven is not provided with a power supply cable. When connecting the appliance electrically, an automatic RCD must be interposed with an opening distance between contacts of at least 0.1" / 3 mm. To connect the appliance electrically it is essential to proceed in the following way:

- Raise the cover of the oven.
- Connect to the terminal block the power cable.

The power supply cable must be of H07-RNF type, with approved minimum cross section as prescribed by the specific directive.

The electrical outlet must be easy to access, no moving should be necessary.

**The electrical connection (plug) must be easily accessible, also following oven installation.**

The distance between the machine and the socket must be adequate to not cause tension in the power supply cable. In addition, the cable must not be located beneath the machine support base.

**If the electrical power supply cable is damaged, it must be replaced by the technical assistance service or by a qualified technician to prevent any risks.**

### Ground connection

It is mandatory that the electrical system is equipped with a ground connection. The appliance must be part of an equipotential system. The connection is done on terminal marked with symbol which you will find near the cable clamp. The equipotential symbol is showed in the following figure.



## OVEN START UP AND USE

### COMMAND PANEL DESCRIPTION

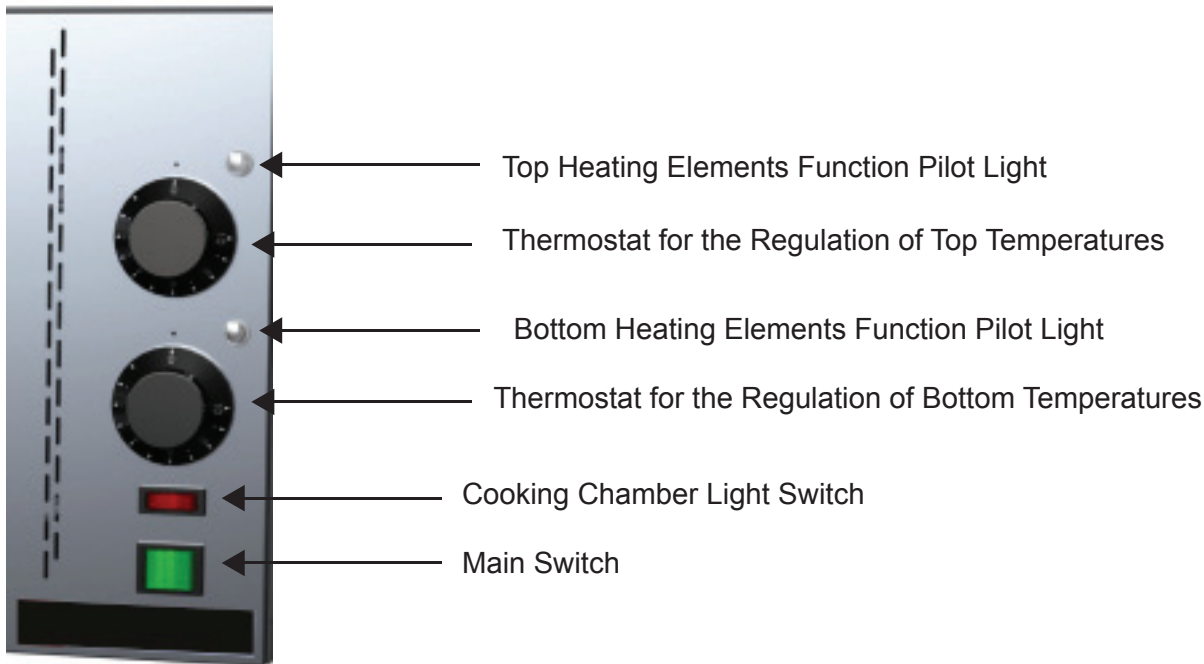

### FIRST LIGHTING OF THE OVEN

At the first use of the appliance it is advisable to heat the empty oven to eliminate bad smells caused by the refractory stones evaporation and the inner metallic parts.

#### Procedure:

- Set the main switch in the position “1” after checking that the oven is connected with the power supply.
- Leave the oven working (empty) for at least 8 hours at the temperature of 300° before proceeding to the first baking.

### START UP PHASE OVEN

After connecting the oven to the electric net set the main switch in position “1”. The analogic thermometer display shows the actual average temperature of the baking chamber. Rotate the thermostat knobs to the expected temperature. In this way top and bottom heating elements are under working and the relevant light signals switch on.

### GENERAL INDICATIONS OF PROPER COOKING

Generally for food products it is not advisable to give precise temperatures and baking time, because of their different characteristics. Particularly, regarding pizza and similar products, time and temperatures depend on the shape and thickness of the dough, as well as on the quantity and typology of the additional ingredients. For those reasons it is always advisable to carry out previously some baking tests, (particularly when it is an absolute new oven), with the aim of understanding as much as possible the characteristics and the functions of the oven.

# Operation

---

**Ideal time and temperature choice varies for baking a pizza correctly; mostly depending on the operator's experience.**

## **WORKING PHASE**

While working, at any time the oven can be modified in its temperature parameters; in addition, pizza baking operation can be verified by inner chamber light. Once the oven has reached the set temperature, it is possible to put in the pizza/s for baking, proceeding as follows:

- Open the door of the oven by the suitable handles.
- To light the inner chamber, set the lighting button in the position "1".
- Put in the oven the pizza/s to bake with suitable instruments for said use.
- Close the door by using the suitable handles and check the baking through the door glass.
- When baking has concluded, open the door by the suitable handles and take out the pizza/s by suitable instruments for said use.

**When opening the door while the oven is on, it is important to stay at the right distance, to avoid being affected by the heat coming out from the chamber.**

**Use suitable instruments to bake in and displace the pizzas in the baking chamber, to avoid burns.**

**When opening the door to bake the pizza/s, do not leave it opened for a long time, to avoid heat dispersion and consequently chamber temperature drop.**

**Avoid oil and fats to drop on bottom; as they will flame at high temperatures.**

## **SHUT DOWN PHASE**

To shut down the oven turn the main switch to the position "0".

# Maintenance

---

**Before performing any maintenance operations, including cleaning, take the following precautions:**

- Ensure that the oven is not working and completely cold.
- Ensure that the electrical power is not present.
- Make certain that the electrical power cannot be accidentally turned on. Disconnect the plug from the electrical power socket.
- Use individual protection devices in compliance with the local directive.
- Always operate using appropriate maintenance tools.
- Once maintenance and repairs are finished, before starting up the oven, reinstall all of the protection devices and reactivate all of the safety devices.

## **ORDINARY MAINTENANCE FOR THE USER**

### **Cleaning of refractory surface**

The oven must be cleaned at the end of each use, in compliance with the hygiene regulations and to safeguard

# Maintenance

machine operation. Before proceeding the oven temperature must be at 350° C for roughly 60 minutes (setting 350° on the top and on the bottom as well), for an easy baking scoriae carbonization. Once the temperature is reached, switch off the oven and wait until the temperature drops to roughly 100°C (the best temperature for cleaning). At this stage disconnect the electric power supply. After dressing in gloves and suitable dresses as protection from burns, open the door and with a brush in natural fiber with a long handle, proceed to a first removal of baking fragments from the refractory stones, then take them out by a suitable vacuum cleaner. At the end, clean the refractory stone with an humid cloth.

## External cleaning of the oven

Oven external areas cleaning, external parts in stainless steel, door glass, and switch panel, must be carried out at cold oven and at disconnected electric power supply. Use a sponge or a soft cloth, not abrasive, slightly humidified with water or possibly with a neutral detergent not corrosive. In any case, do not use water jets which can penetrate through the electric parts and easily damage them, as well as creating hazardous conditions.

# Troubleshooting

SYMPTOM	POSSIBLE CAUSE	SUGGESTED REMEDY
The oven doesn't heat despite the temperatures are correctly set. The pilot lights of the heating elements are off.	Main switch off (positioned on "0").	Set the main switch to position "1".
The oven doesn't heat despite the main switch is on (position 1) and the temperatures are correctly set. The function pilot lights of the heating elements are off.	No electric Energy in the net.	Check the general contactor, the socket, the plug, and the supply cable.
The oven does not switch on and the digital display is off.	Main switch off (positioned on "0").	Set the main switch to position "1".
The display is off in spite of the main switch being on position 1 and the electric supply is in order.	Digital control panel defected.	Replace the Digital control panel.
Inner light bulb does not switch on.	Burned inner light bulb.	Replace inner light bulb.
	Inner light bulb switch defected.	Replace light bulb switch.
	No electric supply power on the light bulb.	Check electric connection with the light bulb.
The baking chamber does not heat suitably.	The set temperature are too low.	Set the right temperature.

# Troubleshooting

The baking chamber does not heat suitably in spite of the temperature being set rightly.	One or more heating elements are defected.	Replace the defecate heating elements.
The temperature continues going up over the set by thermostats.	Thermostat probe or thermostat contacts defective.	Check and if necessary replace the thermostat/s.

## REFERENCE

Item Number	Model Number	Description	Manufacturer Model Number
40633	PE-IT-0005	Pizza Oven Compact Series Single Chamber Dims 13.75 x 13.75 x 3.3 Red 220/60/1 M35/8-M cQPSus	M35/8-M
40634	PE-IT-0010	Pizza Oven Compact Series Single Chamber Dims 19.6 x 19.6 x 5.11 Red 220/60/1 M50/13-M cQPSus	M50/13-M

# Parts Breakdown

Model PE-IT-0005 40633

Model PE-IT-0010 40634

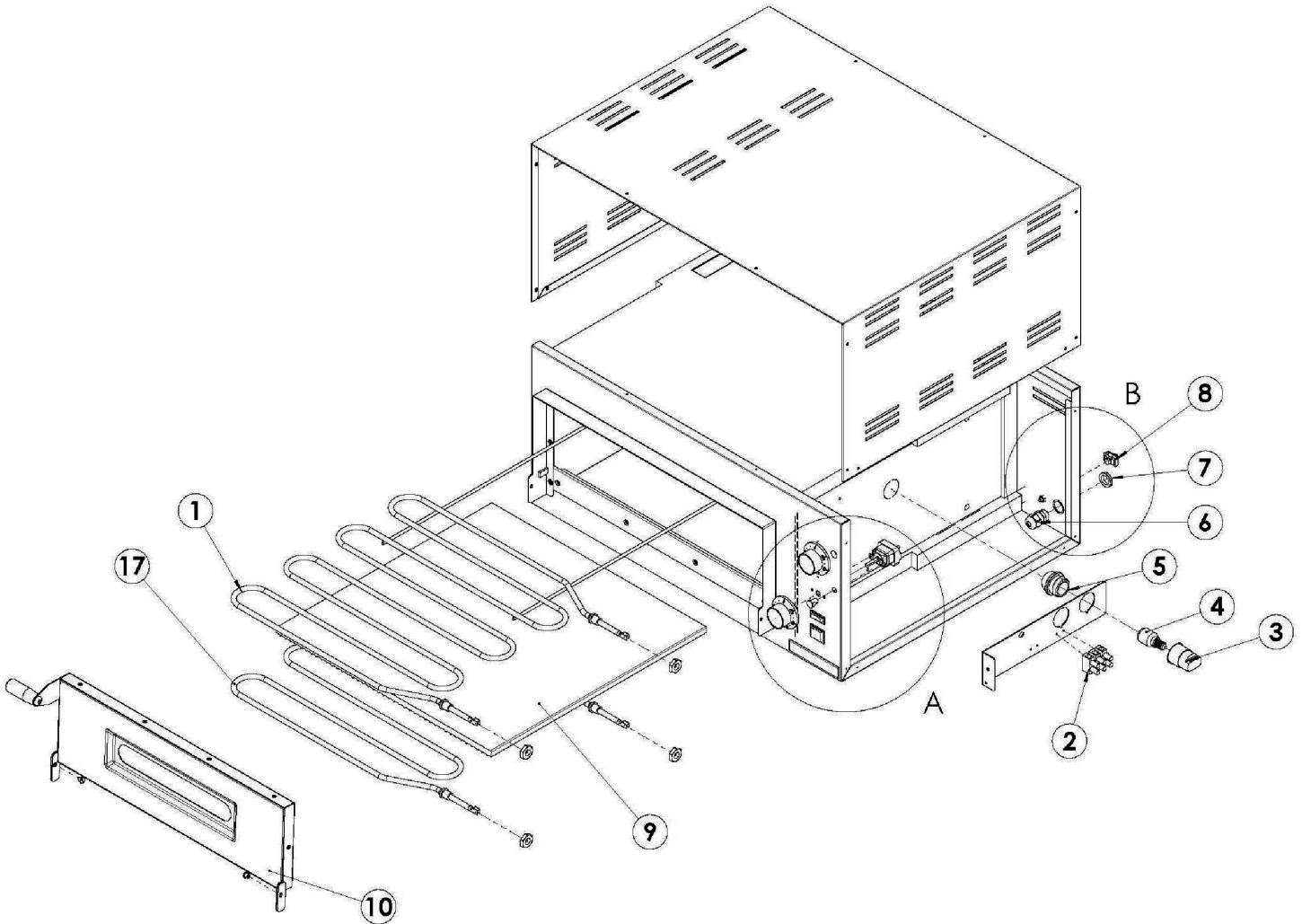

# Parts Breakdown

**Model PE-IT-0005** 40633

**Model PE-IT-0010** 40634

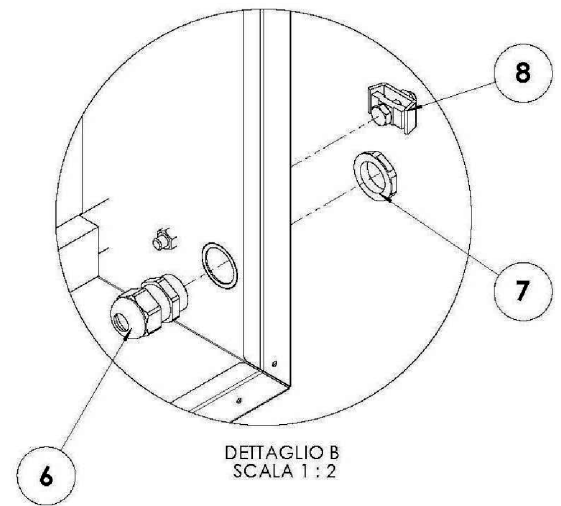
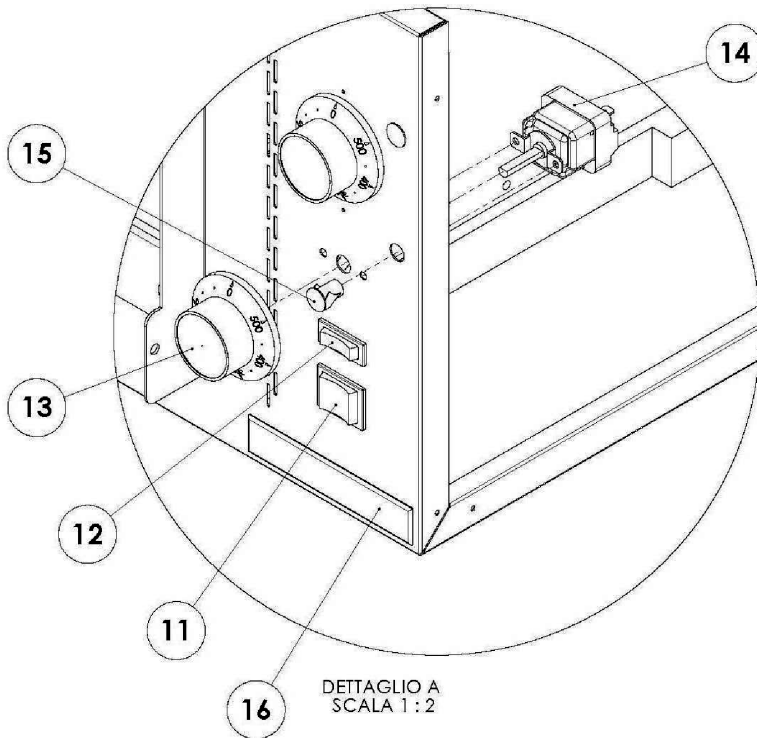

# Parts Breakdown

**Model PE-IT-0005** 40633

**Model PE-IT-0010** 40634

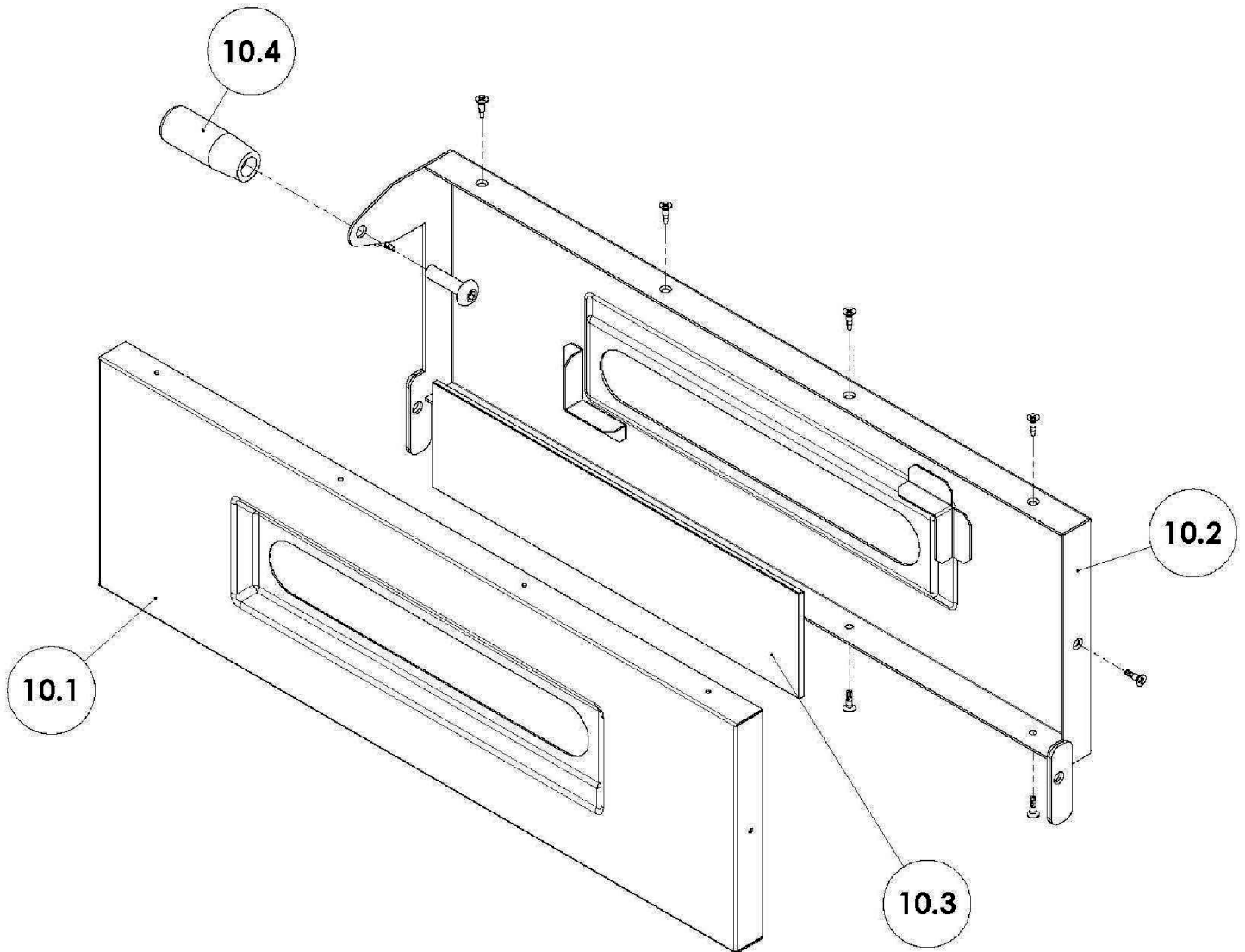

# Parts Breakdown

## Model PE-IT-0005 40633

Item No.	Description	Position	Item No.	Description	Position	Item No.	Description	Position
42830	Heating Element 1400W 230V for M35/8-M	1	42838	Brick 350 x 350 x 19 for M35/8-M	9	42048	Luminous Unipolar Red Switch for M35/8-M	12
42831	Terminal Board 16 SQmm 750V-76A for M35/8-M	2	42839	Ensemble Door for M35/8-M	10	65540	Thermostat Knob AP10 (Deg C) for M35/8-M	13
42040	Lamp Holder E14 Code BJB77.222 for M35/8-M	3	42840	Door for M35/8-M	10.1	42050	Ego Unipolar Thermostat for Ovens-Rating 455 Degrees for M35/8-M	14
43657	Lamp 25W 240V COD2540 for M35/8-M	4	42841	Door Internal Panel Assembly for M35/8-M	10.2	65541	Pilot Light 250V for M35/8-M	15
42046	Dome Form Lamp Glass 77.222.503 for M35/8-M	5	42842	Pyroceram 300 x 75 x 4mm for M35/8-M	10.3	42849	Resin Bonded Label for M35/8-M	16
72483	Cable Fastener for M35/8-M	6, 7	42843	Elesa Handle for M35/8-M	10.4	42859	Heating Element for M35/8-M	17
42837	Equipotential Fitting for M35/8-M	8	42844	Bipolar/Lighted/Green Switch for M35/8-M	11			

## Model PE-IT-0010 40634

Item No.	Description	Position	Item No.	Description	Position	Item No.	Description	Position
42043	Heating Element 1800 W 230V for M50/13-M	1, 17	42837	Equipotential Fitting for M50/13-M	8	42844	Bipolar/Lighted/Green Switch for M50/13-M	11
42831	Terminal Board 16 SQmm 750V-76A for M50/13-M	2	72486	Brick 50x50x14 for M50/13-M	9	42048	Luminous Unipolar Red Switch for M50/13-M	12
42040	Lamp Holder E14 Code BJB77.222 for M50/13-M	3	65542	Ensemble Door Compact for M50/13-M	10	65540	Thermostat Knob AP10 (Deg C) for M50/13-M	13
43657	Lamp 25W 240V COD2540 for M50/13-M	4	65543	Door Compact for M50/13-M	10.1	42050	Ego Unipolar Thermostat for Ovens-Rating 455 Degrees for M50/13-M	14
42046	Dome Form Lamp Glass 77.222.503 for M50/13-M	5	65544	Door Internal Panel Assembly for M50/13-M	10.2	65541	Pilot Light 250V for M50/13-M	15
42835	Cable Fastener for M50/13-M	6	42842	Pyroceram 300 x 75 x 4mm for M50/13-M	10.3	42849	Resin Bonded Label for M50/13-M	16
42836	Binder for M50/13-M	7	42843	Elesa Handle for M50/13-M	10.4			

# Electrical Schematics

**Model PE-IT-0005** 40633

**Model PE-IT-0010** 40634

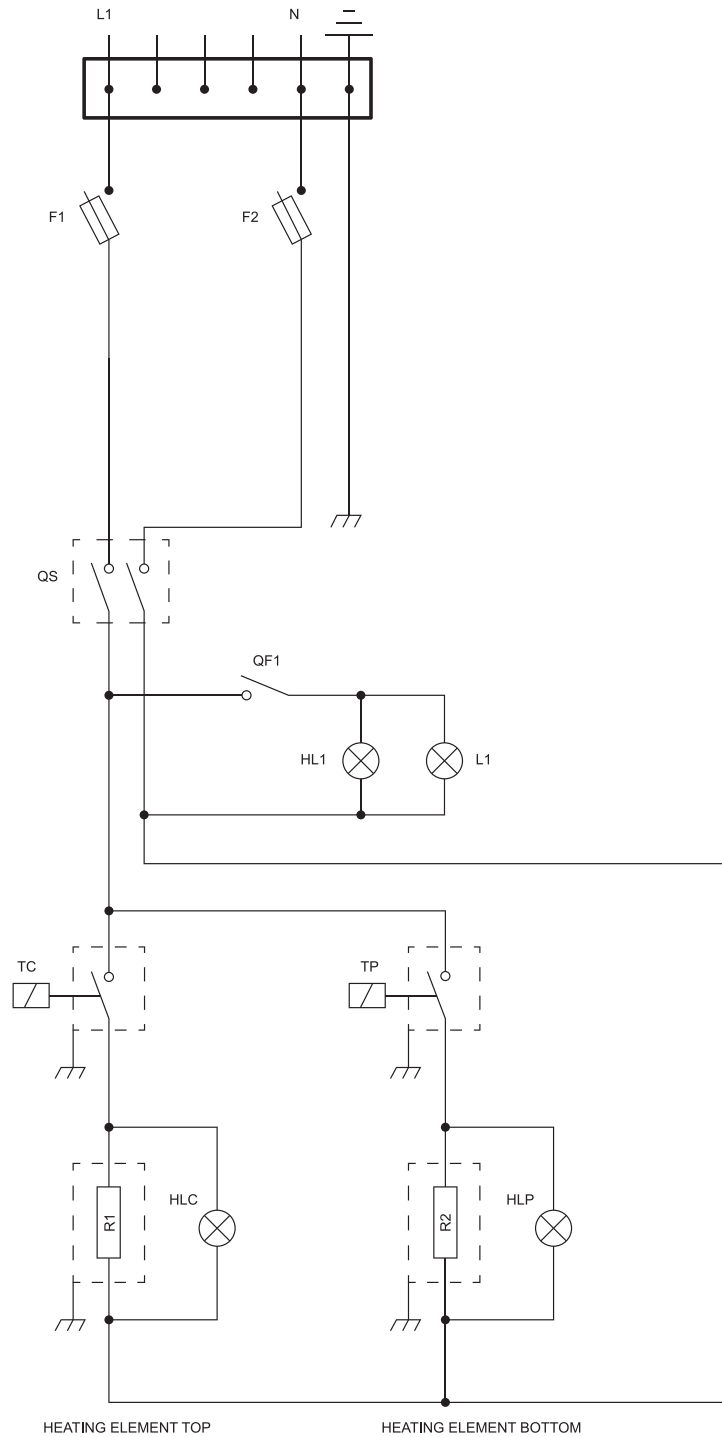





# Warranty Registration

Thank you for purchasing an Omcan product. To register your warranty for this product, complete the information below, tear off the card at the perforation and then send to the address specified below. You can also register online by visiting:

Merci d'avoir acheté un produit Omcan. Pour enregistrer votre garantie pour ce produit, complétez les informations ci-dessous, détachez la carte au niveau de la perforation, puis l'envoyer à l'adresse spécifiée ci-dessous. Vous pouvez également vous inscrire en ligne en visitant:

Gracias por comprar un producto Omcan usted. Para registrar su garantía para este producto, complete la información a continuación, cortar la tarjeta en la perforación y luego enviarlo a la dirección indicada a continuación. También puede registrarse en línea en:

<https://omcan.com/warranty-registration/>

For mailing in Canada

Pour postale au Canada

Por correo en Canadá

**OMCAN**

PRODUCT WARRANTY REGISTRATION

3115 Pepper Mill Court,

Mississauga, Ontario

Canada, L5L 4X5

For mailing in the US

Pour diffusion aux États-Unis

Por correo en los EE.UU.

**OMCAN**

PRODUCT WARRANTY REGISTRATION

4450 Witmer Industrial Estates, Unit 4,

Niagara Falls, New York

USA, 14305

*or email to: [service@omcan.com](mailto:service@omcan.com)*



Purchaser's Information

Name: \_\_\_\_\_

Address: \_\_\_\_\_

City: \_\_\_\_\_ Province or State: \_\_\_\_\_ Postal or Zip: \_\_\_\_\_

Country: \_\_\_\_\_

Dealer from which Purchased: \_\_\_\_\_

Dealer City: \_\_\_\_\_ Dealer Province or State: \_\_\_\_\_

Invoice: \_\_\_\_\_

Model Name: \_\_\_\_\_ Model Number: \_\_\_\_\_

Machine Description: \_\_\_\_\_

Date of Purchase (MM/DD/YYYY): \_\_\_\_\_

Would you like to extend the warranty?  Yes  No

Company Name: \_\_\_\_\_

Telephone: \_\_\_\_\_

Email Address: \_\_\_\_\_

Type of Company:

Restaurant  Bakery  Deli

Butcher  Supermarket  Caterer

Institution (specify): \_\_\_\_\_

Other (specify): \_\_\_\_\_

Serial Number: \_\_\_\_\_

Date of Installation (MM/DD/YYYY): \_\_\_\_\_

**Thank you for choosing Omcan | Merci d'avoir choisi Omcan | Gracias por elegir Omcan**



Since 1951 Omcan has grown to become a leading distributor of equipment and supplies to the North American food service industry. Our success over these many years can be attributed to our commitment to strengthen and develop new and existing relationships with our valued customers and manufacturers. Today with partners in North America, Europe, Asia and South America, we continually work to improve and grow the company. We strive to offer customers exceptional value through our qualified local sales and service representatives who provide convenient access to over 5,000 globally sourced products.

---

Depuis 1951 Omcan a grandi pour devenir un des “leaders” de la distribution des équipements et matériel pour l’industrie des services alimentaires en Amérique du Nord. Notre succès au cours de ces nombreuses années peut être attribué à notre engagement à renforcer et à développer de nouvelles et existantes relations avec nos clients et les fabricants de valeur. Aujourd’hui avec des partenaires en Amérique du Nord, Europe, Asie et Amérique du Sud, nous travaillons continuellement à améliorer et développer l’entreprise. Nous nous efforçons d’offrir à nos clients une valeur exceptionnelle grâce à nos ventes locales qualifiées et des représentants de service qui offrent un accès facile à plus de 5000 produits provenant du monde entier.

---

Desde 1951 Omcan ha crecido hasta convertirse en un líder en la distribución de equipos y suministros de alimentos en América del Norte industria de servicios. Nuestro éxito en estos años se puede atribuir a nuestro compromiso de fortalecer y desarrollar nuevas relaciones existentes con nuestros valiosos clientes y fabricantes. Hoy con socios de América del Norte, Europa, Asia y América del Sur, que trabajan continuamente para mejorar y crecer la empresa. Nos esforzamos por ofrecer a nuestros clientes valor excepcional a través de nuestro local de ventas y representantes de los servicios que proporcionan un fácil acceso a más de 5,000 productos con origen a nivel mundial.

