



Vertical Meat Slicers

***Models MS-IT-0300-V, 0330-V, 0350-V, 0370-V
Items 13647, 13648, 13649, 13650
Instruction Manual***



Revised - 02/02/2018

Toll Free: 1-800-465-0234
Fax: 905-607-0234
Email: service@omcan.com
www.omcan.com

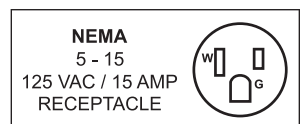

Table of Contents

Model MS-IT-0300-V / Model MS-IT-0330-V
Model MS-IT-0350-V / Model MS-IT-0370-V

Section	Page
General Information -----	3 - 4
Safety and Warranty -----	4 - 6
Technical Specifications -----	6 - 8
Installation and Operation -----	9 - 12
Maintenance -----	12 - 20
Troubleshooting -----	21 - 22
Parts Breakdown -----	23 - 42
Electrical Schematics -----	43
Notes -----	44 - 46
Warranty Registration -----	47



General Information

Omcan Manufacturing and Distributing Company Inc., Food Machinery of America, Inc. dba Omcan and Omcan Inc. are not responsible for any harm or injury caused due to any person's improper or negligent use of this equipment. The product shall only be operated by someone over the age of 18, of sound mind, and not under the influence of any drugs or alcohol, who has been trained in the correct operation of this machine, and is wearing authorized, proper safety clothing. Any modification to the machine voids any warranty, and may cause harm to individuals using the machine or in the vicinity of the machine while in operation.

CHECK PACKAGE UPON ARRIVAL

Upon receipt of an Omcan shipment please inspect for external damage. If no damage is evident on the external packaging, open carton to ensure all ordered items are within the box, and there is no concealed damage to the machine. If the package has suffered rough handling, bumps or damage (visible or concealed), please note it on the bill of lading before accepting the delivery and contact Omcan within 24 hours, so we may initiate a claim with the carrier. A detailed report on the extent of the damage caused to the machine must be filled out within three days, from the delivery date shown in the shipping documents. Omcan has no recourse for damaged products that were shipped collect or third party.

Before operating any equipment, always read and familiarize yourself with all operation and safety instructions.

Omcan would like to thank you for purchasing this machine. It's of the utmost importance to save these instructions for future reference. Also save the original box and packaging for shipping the equipment if servicing or returning of the machine is required.

Omcan Fabrication et distribution Compañie Limité et Food Machinery d'Amerique, dba Omcan et Omcan Inc. ne sont pas responsables de tout dommage ou blessure causé du fait que toute personne ait utilisé cet équipement de façon irrégulière. Le produit ne doit être exploité que par quelqu'un de plus de 18 ans, saine d'esprit, et pas sous l'influence d'une drogue ou d'acohol, qui a été formé pour utiliser cette machine correctement, et est vêtu de vêtements de sécurité approprié. Toute modification de la machine annule toute garantie, et peut causer un préjudice à des personnes utilisant la machine ou des personnes à proximité de la machine pendant son fonctionnement.

VÉRIFIEZ LE COLIS DÈS RÉCEPTION

Dès réception d'une expédition d'Omcan veuillez inspecter pour dommages externes. Si aucun dommage n'est visible sur l'emballage externe, ouvrez le carton afin de s'assurer que tous les éléments commandés sont dans la boîte, et il n'y a aucun dommage dissimulé à la machine. Si le colis n'a subi aucune mauvaises manipulations, de bosses ou de dommages (visible ou cachée), notez-le sur le bond de livraison avant d'accepter la livraison et contactez Omcan dans les 24 heures qui suivent, pour que nous puissions engager une réclamation auprès du transporteur. Un rapport détaillé sur l'étendue des dommages causés à la machine doit être rempli dans un délai de trois jours, à compter de la date de livraison indiquée dans les documents d'expédition. Omcan n'a aucun droit de recours pour les produits endommagés qui ont été expédiées ou cueilli par un tiers transporteur.

General Information

Avant d'utiliser n'importe quel équipement, toujours lire et vous familiariser avec toutes les opérations et les consignes de sécurité.

Omcan voudrais vous remercier d'avoir choisi cette machine. Il est primordial de conserver ces instructions pour une référence ultérieure. Également conservez la boîte originale et l'emballage pour l'expédition de l'équipement si l'entretien ou le retour de la machine est nécessaire.

Omcan Empresa De Fabricacion Y Distribucion Inc. Y Maquinaria De Alimentos De America, Inc. dba Omcan y Omcan Inc. no son responsables de ningun daño o perjuicio causado por cualquier persona inadecuada o el uso descuidado de este equipo. El producto solo podra ser operado por una persona mayor de 18 años, en su sano juicio y no bajo alguna influencia de droga o alcohol, y que este ha sido entrenado en el correcto funcionamiento de esta máquina, y ésta usando ropa apropiada y autorizada. Cualquier modificación a la máquina anula la garantía y puede causar daños a las personas usando la máquina mientras esta en el funcionamiento.

REVISE EL PAQUETE A SU LLEGADA

Tras la recepcion de un envio Omcan favor inspeccionar daños externos. Si no hay daños evidentes en el empaque exterior, Habra el carton para asegurarse que todos los articulos solicitados estén dentro de la caja y no encuentre daños ocultos en la máquina. Si el paquete ha sufrido un manejo de poco cuidado, golpes o daños (visible o oculto) por favor anote en la factura antes de aceptar la entrega y contacte Omcan dentro de las 24 horas, de modo que podamos iniciar una reclamación con la compañía. Un informe detallado sobre los daños causados a la máquina debe ser llenado en el plazo de tres días, desde la fecha de entrega que se muestra en los documentos de envío. Omcan no tiene ningun recurso por productos dañados que se enviaron a recoger por terceros.

Antes de utilizar cualquier equipo, siempre leer y familiarizarse con todas las instrucciones de operación y seguridad.

Omcan quisiera darles las gracias por la compra de esta máquina. Es de la máxima importancia para guardar estas instrucciones para referencias en el futuro. También guarde la caja original y el embalaje para envío del equipo si el mantenimiento o la devolución de la máquina es necesaria.

Safety and Warranty

LIMITS OF USE – SAFETY NORMS

These machine were designed and built to slice foodstuff in compliance to the norms of the CE 2006/95/EEC, 93/68/EEC, 2006/42/EEC, 2002/72/EEC, 2004/108 CE, REG 1935/2004/EEC, 2002/95/CE (RoHS) and to the following regulations EN1974, EN ISO12100-1, EN ISO12100-2, EN 294, EN60204-1, EN60335-1, EN60335-2-64.

Safety and Warranty

GENERAL SAFETY REGULATIONS

The slicers must be used only by suitably trained personnel. Furthermore, this personnel must have read this manual carefully. In particular, please comply to the following instructions:

- Install the machine according to the instructions contained in the “Installation” section;
- Do not remove the transparent protections, do not modify nor exclude the mechanical and electrical safety devices;
- Do not use the machine with improvised connections, or provisional or non insulated cables;
- Check the power cable and gland plate on the machine body regularly and when necessary have them replaced by qualified personnel;
- In case of anomalies, defective operation, incorrect movement, unusual noise, etc stop the machine immediately;
- Before cleaning or servicing, disconnect the machine from the mains;
- Always use scratch-proof and non-slip gloves during cleaning or maintenance;
- Lay or remove the goods to be sliced on the sliding plate only when the latter is completely pushed back and the thickness control knob positioned to 0;
- To move the carriage tray when slicing, use the handle or the product grip handle;
- For extraordinary maintenance (to replace the sharpener wheels, the blade, or others) please contact the manufacturer or qualified and duly authorized personnel;
- Avoid running the slicers with no product on it;
- The slicers are equipped with a ventilated motor. Extended continual use is not recommended. Let the motor cool down after 30 minutes of use.

MANUFACTURER’S WARRANTY AND LIABILITY

The manufacturer’s warranty covering the good functioning of the machines and their compliance to the service for which they have been designed depends on the correct application of the instructions contained in this manual. The Manufacturer assumes no liability either direct or indirect deriving from:

- Failure to comply with the instructions contained in this manual;
- Use of the machine by personnel who has not read or fully understood the content of this manual;
- Use not complying to the specific norms currently applicable in the country of installation;
- Unauthorized modifications and/or repairs;
- Use of non original accessories or spare parts;
- Exceptional events.

ENVIRONMENTAL CONDITIONS OF USE

Temperature: from -5 °C a + 40 °C

Relative humidity: max 95%

OPENING THE BOX

On reception check packaging integrity, otherwise inform the forwarding agent or the area agent immediately. To unpack the machine, proceed as follows:

Safety and Warranty

- Open the box and remove your copy of the manual of use and maintenance, then proceed according to the instructions found on that manual;
- Lift the machine still wrapped in a transparent polyethylene sheet and extract it from the box;
- Now check the box content and make sure it corresponds to what shown on the external label.

1 YEAR PARTS AND LABOR BENCH WARRANTY

Within the warranty period, contact Omcan Inc. at 1-800-465-0234 to schedule a drop off to either an Omcan authorized service depot in the area, or to an Omcan Service warehouse to repair the equipment.

Unauthorized maintenance will void the warranty. Warranty covers electrical and part failures, not improper use.

Please see www.omcan.com/warranty.html for complete info.

WARNING:

The packaging components are classified as normal solid urban waste and can therefore be disposed of without difficulty.

In any case, for suitable recycling, we suggest disposing of the products separately (differentiated waste) according to the current norms.

DO NOT DISCARD ANY PACKAGING MATERIALS IN THE ENVIRONMENT!

Technical Specifications

The machine is essentially made of a base supporting a circular blade mounted in a vertical position. This blade is driven by an electrical motor to slice foodstuffs. The machine is equipped with a carriage holding a product tray and sliding on a bar mounted under the base top, parallel to the blade. Slice thickness is adjusted by means of a gauge plate mounted in front of the blade. This plate, against which rests the product to be sliced is moved transversely with respect to the blade by a value corresponding to the desired slice thickness. The product is fed to the machine towards the gauge plate. All the machine components are made of polished and anodically oxidized aluminium alloy, of stainless steel and food grade plastic material. The blade is driven by an electrical motor, transmission is by means of a longitudinally grooved belt. The machine is started and stopped by a control button or switch. These models have a built-in blade sharpener.

MECHANICAL AND ELECTRICAL SAFETY DEVICES

The following mechanical safety devices were installed:

- A series of aluminium and transparent plastic guards on the product carriage.

Technical Specifications

On request the following are available:

- Safety micro-switch preventing the motor from starting when the blade guard is removed.

WARNING: RESIDUAL RISKS

Notwithstanding all the possible cautions taken during the design and the construction of the machine, residual risks (cutting) still exist during use or during cleaning or maintenance. Therefore be careful and **PAY THE UTMOST ATTENTION** to what you are doing. **DO NOT** use the machine if you are not in perfect psychological and physical conditions. **DO NOT ALLOW** anyone near the machine when it is in use. **ALWAYS** wear gloves that can resist cuts or tears when cleaning, lubricating or sharpening the blade. Slice only the products mentioned as sliceable. **NEVER** try to slice products that have been mentioned as non sliceable.

ACCESSORIES

If not otherwise defined at the moment of order, the machines are supplied together with the following:

- Instructions manual for installation, use and maintenance.

PRODUCTS THAT CAN BE SLICED

- All types of cold cuts (raw, cooked, smoked);
- Meat without bone (raw or cooked, at a temperature not less than + 3 °C);
- Vegetables (all types).

PRODUCTS THAT MUST NOT BE SLICED:

- Frozen or deep-frozen food;
- Food containing bones (meat or fish);
- Any other non-food product;
- Cheese.

Technical Specifications

MAIN COMPONENTS

F300TCV
F330TCV
F350TCV
F370TCV

- | | |
|---------------------------------|---|
| 1. Startup Button | 11. Blade |
| 2. Stop Button | 12. Manufacturer Identification Plate, Machine Data |
| 3. Slice Thickness Control Knob | 13. Product Grip Hand Protection |
| 4. Adjustable Foot | 14. Product Protection |
| 5. Carriage Tray Support | 15. Product Tray Handle |
| 6. Base | 16. Blade Plate Tie-Rod |
| 7. Product Tray | 17. Supply Cord |
| 8. Blade Plate | 18. Gauge Plate |
| 9. Product Grip | 19. Sharpener |
| 10. Blade | 20. Product Tray |
| 11. Product Grip Handle | 21. Slices Guard |

Illustrations may differ from actual machines.

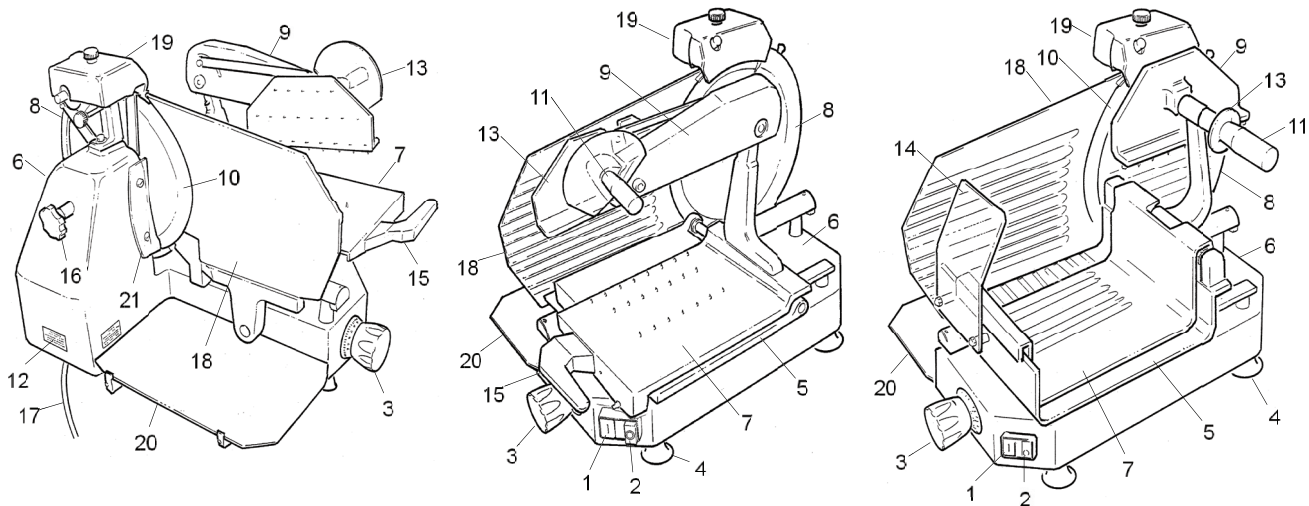

Installation and Operation

INSTALLING THE MACHINE

Position the machine on a well levelled, smooth and dry top suitably dimensioned to withstand the machine weight.

ELECTRICAL CONNECTION

Install the machine near a compliant outlet derived from a system meeting the current norms.

The user is responsible for ascertaining that the electrical system is suitably dimensioned and functions correctly (supply line, outlet, distribution panel, differential protecting breaker, grounding).

Before carrying out the connection ascertain that the mains characteristics correspond to those indicated on the machine plate.

COMMANDS

START AND STOP BUTTONS

- Turn the switch or press the white or green button (1) to start running the blade;
- The light turns on to indicate that the machine works correctly;
- Turn the switch or press the red or black button (3) to stop the blade.

Slice thickness can be adjusted by turning the graduated knob (4) counterclockwise.

Thickness adjustment range: see paragraph "Technical description and conditions of use"

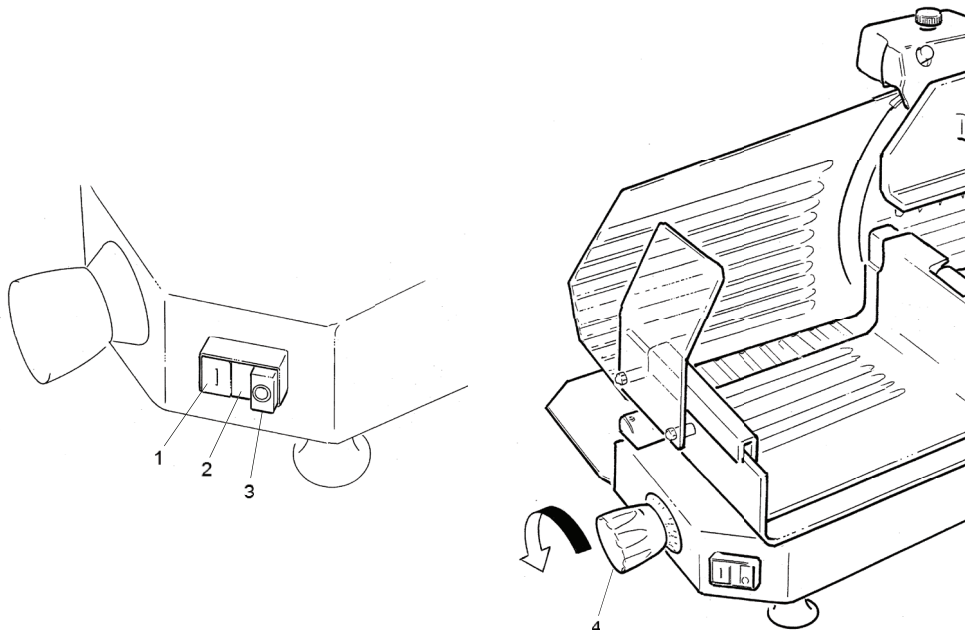

Installation and Operation

FUNCTIONING TEST AND BLADE ROTATION DIRECTION

Start the machine and check whether the light is on; make sure that the blade rotates in the direction indicated by the arrow (counterclockwise if you look at the machine from the blade plate side).

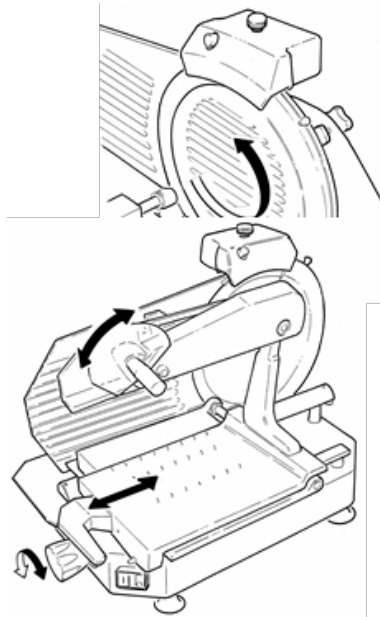

- Ascertain that the carriage and the product grip slide correctly;
- Ascertain that the gauge plate works and adjust thickness to correct value.

USING THE MACHINE

LOADING THE PRODUCT ON THE TRAY AND SLICING

Ascertain that the thickness control knob is correctly positioned to '0';

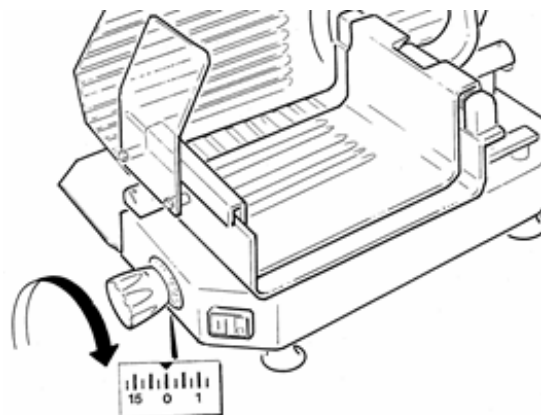

Installation and Operation

- Draw back the carriage completely (towards the operator) to loading position;
- Lift the product grip and set it in at rest position;

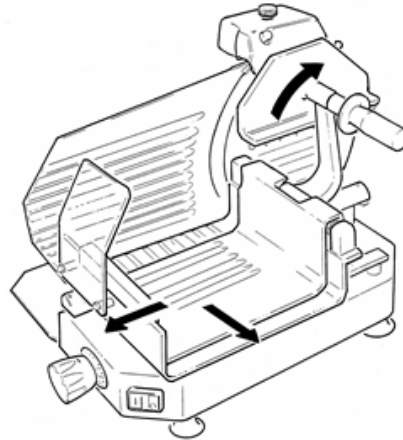

- Lay the product to be sliced on the tray;

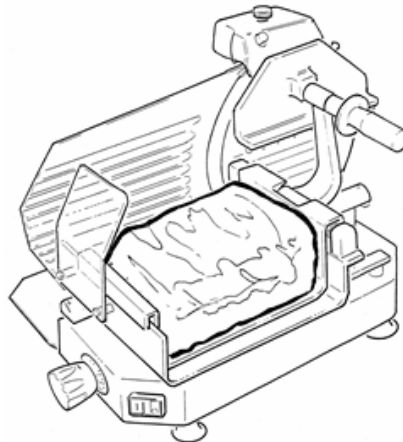

- Secure by means of the product grip by exerting a slight pressure;

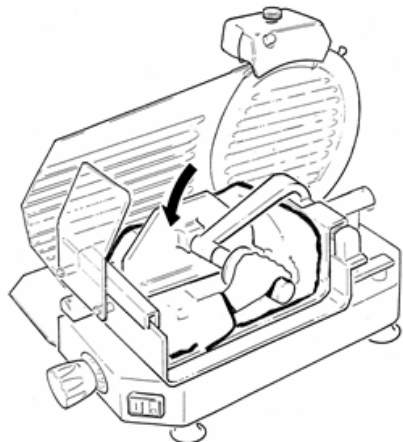

Installation and Operation

- Adjust the thickness gauge. Start the blade by turning the switch or by pressing on the white or green button;
- Grip the handle of the product grip and start the forward and backward slicing movement. The product travels towards the gauge plate by pushing towards the blade;
- When finished, return the thickness control knob to '0' and draw the carriage back.;
- Stop the blade by turning the switch or by pressing the red or black button.

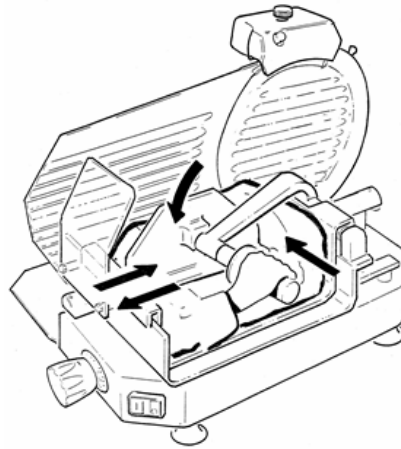

Maintenance

CLEANING THE SLICER

GENERAL

The machine must always be accurately cleaned at least once a day, and more often if necessary. Always wear protective gloves.

DISASSEMBLING THE MACHINE FOR CLEANING

- Disconnect the plug from the mains;
- Turn the gauge plate knob to '0';

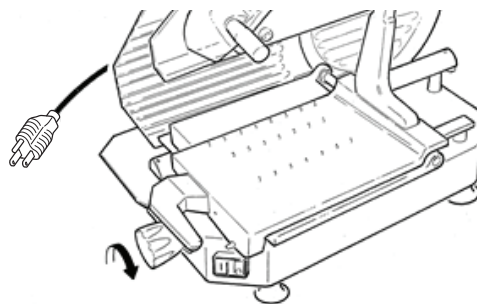

Maintenance

- Remove the various components as described in the following paragraphs.
- Completely unscrew (counterclockwise) the blade guard rod;
- If the blade guard is blocked, press on the rod knob to move it a little;

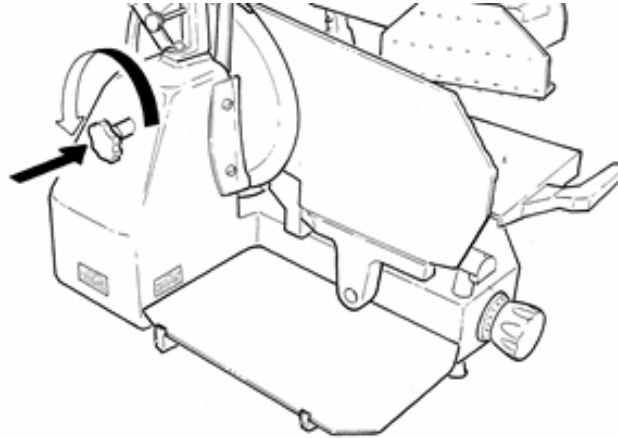

- Extract the rod and remove the blade guard using for this operation only the side knobs.

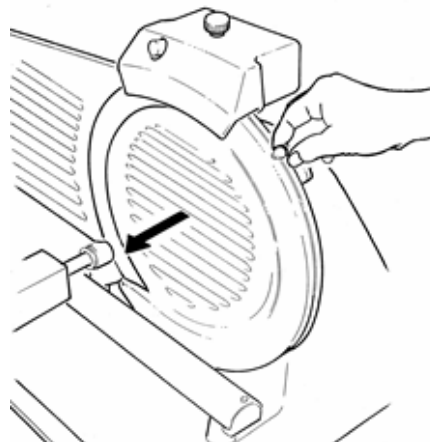

- Loosen and remove the two fixing screws with knurled head;
- Remove the slice guard.

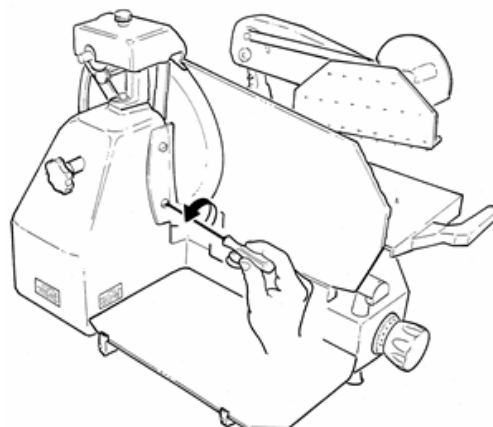

Maintenance

DISASSEMBLING THE SHARPENER

- Loosen the sharpener blocking side knob;

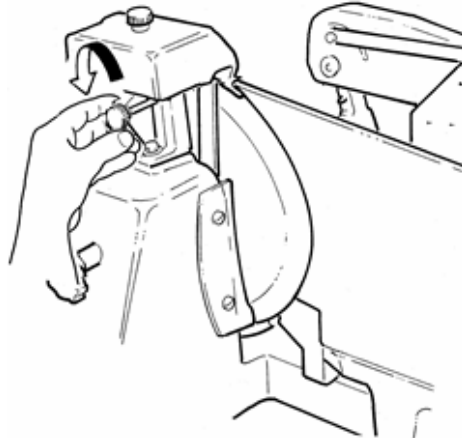

- Remove the complete sharpener unit by pulling it upwards.

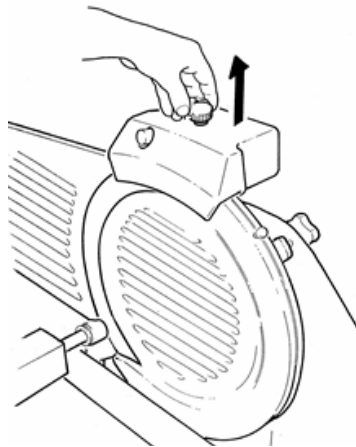

DISASSEMBLING THE PRODUCT TRAY

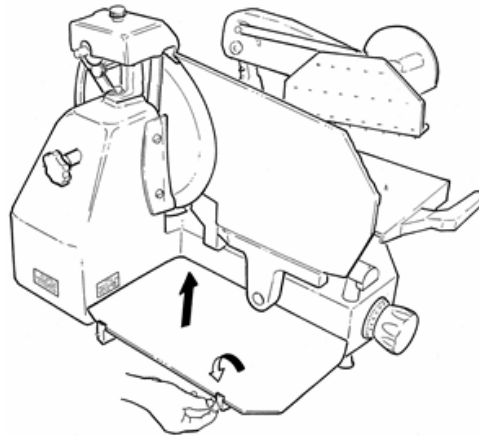

- Loosen the knurled screw as shown in the picture and remove the tray by lifting it.

To clean the machine body and the blade use only a cloth damped with water and biodegradable lathery detergent having 7-8 pH and at a temperature not below + 30°C.

Do not clean the machine by using water or vapor spouts or similar systems.

WARNING: Use scratch proof and non-slip gloves to carry out the following operations. Proceed carefully and pay attention to what you are doing.

DANGER OF CUTTING!

Cleaning the blade:

Press a cloth damped with water over the blade surface and slowly move it from the centre to the external side, as shown in the picture, over the blade guard side and the opposite side.

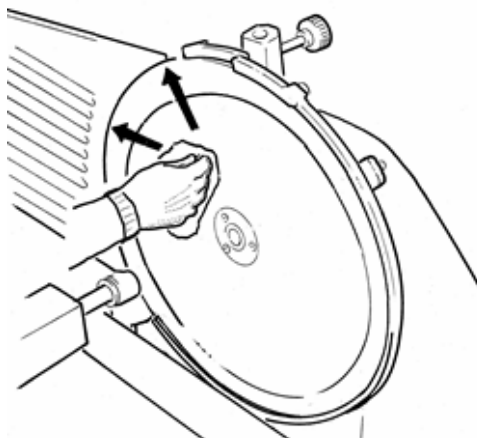

Maintenance

Cleaning the optional safety ring:

Pass a cloth damped with water through the Blade and the safety ring as shown in the picture.

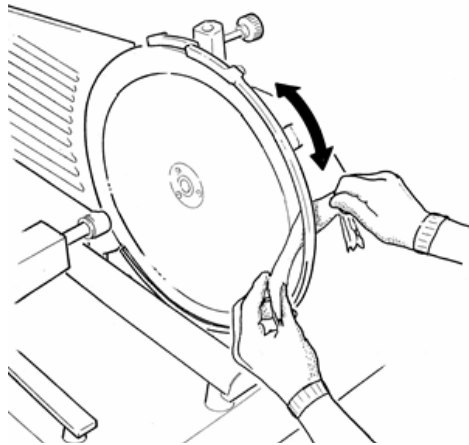

Cleaning of the section under the product tray and of sliding plate

Bring the sliding plate near to the operator and lift the product tray up to the rest position. Clean with a cloth damped with water and carefully dry.

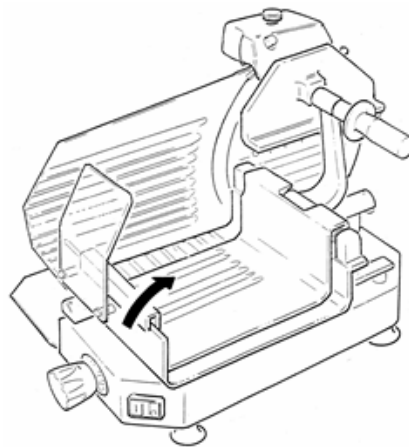

REASSEMBLING THE MACHINE

Proceed as indicated for the previous operations but in reverse order.

GENERAL

The operator is allowed to perform the following maintenance operations:

- Blade sharpening: regularly (intervals and duration obviously depend on the use of the equipment, time of use and type of product sliced);

Maintenance

- Lubrication of carriage sliding guides: once a week.
- Lubrication of product grip sliding bar: once a week.
- Adjustment of motor belt tension: as required.
- Checking the power supply cord conditions and of the gland plate: from time to time.

WARNING: Maintenance must always be carried out when the machine is disconnected from the mains and if no other position is specifically required, with the thickness control knob on '0'.

The following maintenance operations are to be entrusted only to personnel authorized by the manufacturer:

- Replacing the blade;
- Replacing the sharpener wheels;
- Replacing the motor transmission belt;
- Replacing electrical system components under the machine base;
- Repairing structural parts, repairing the components under the base.

BLADE SHARPENING:

Before proceeding, clean the machine accurately as explained in the previous paragraphs:

WARNING: Sharpening can be done only up to 12 mm of the blade diameter value. Beyond this value, the **BLADE MUST BE REPLACED ONLY** by personnel **AUTHORIZED BY THE MANUFACTURER**.

Clean the blade accurately using denaturised alcohol to degrease it; Operate the graduated knob by turning it towards the left to open completely;

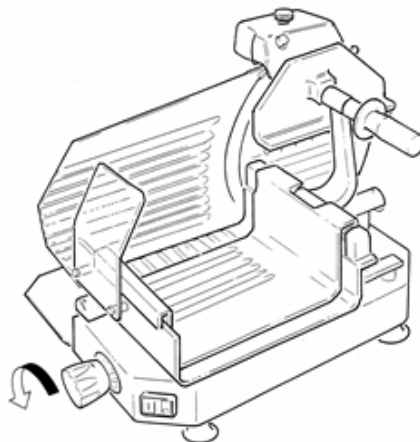

Maintenance

Loosen the knob (1), lift and rotate the sharpener by 180° (2) and insert the wheels on the slicer blade. Tighten the knob;

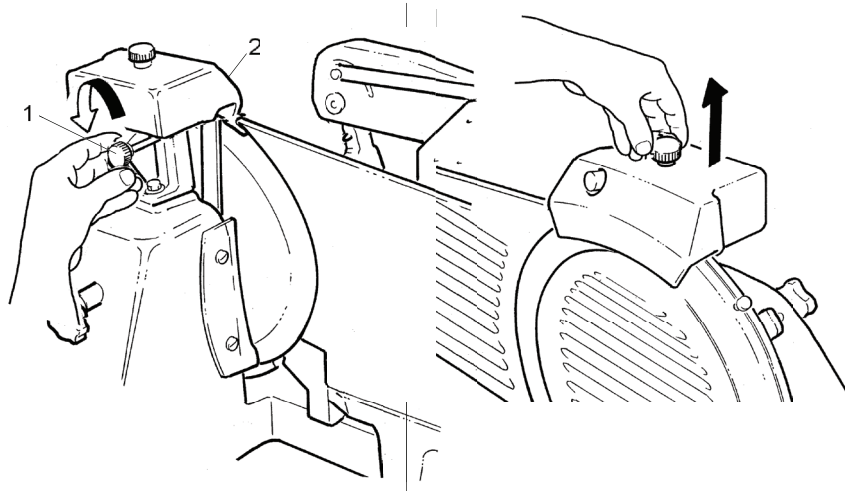

Operate the Blade by using the switch (3), keep the small button (4) pushed; Allow the blade to rotate for about 30 to 40 seconds then use the switch (5) to stop it.

Brush a pencil lightly on the external side of the blade to check for a slight spud; **We advise performing this operation with the utmost care, as the blade is extremely sharp.**

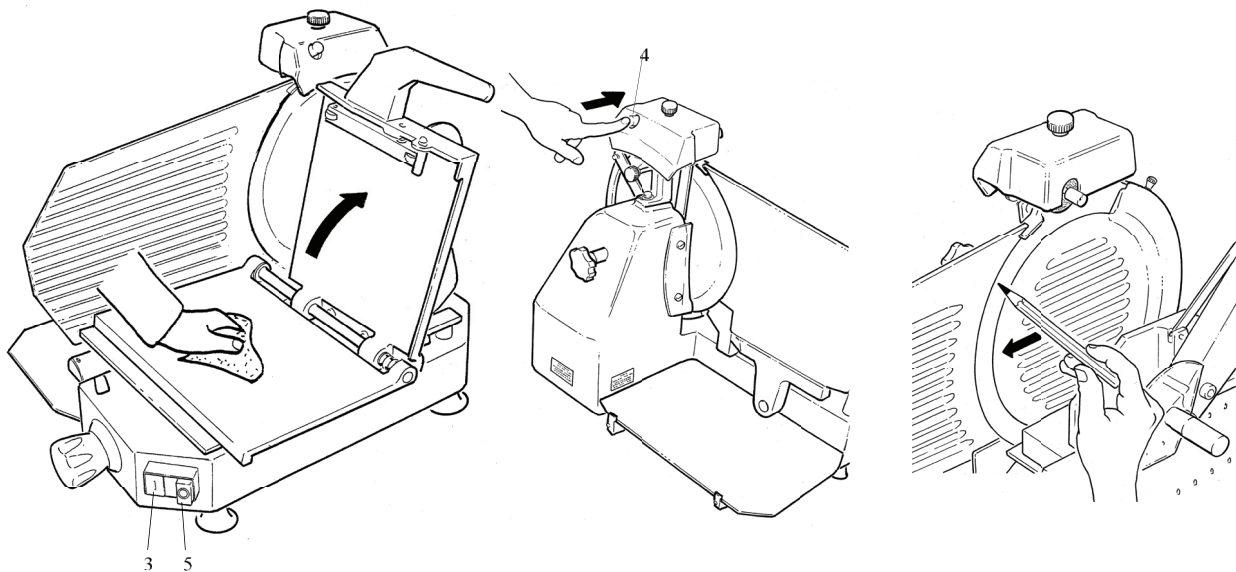

Maintenance

If some spud is found, operate the switch (3) again for 3 to 4 seconds by pressing the buttons 4 and 6 at the same time.

DO NOT PROLONG THIS OPERATION BEYOND THE FEW SECONDS MENTIONED OTHERWISE THE BLADE EDGE WILL WARP.

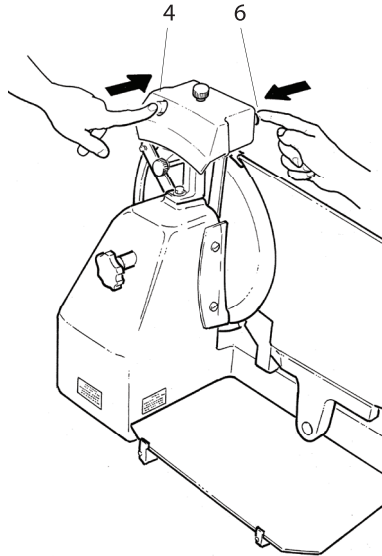

After completing sharpening, we advise cleaning the wheels using a small brush and alcohol. Now return the sharpener to its original position.

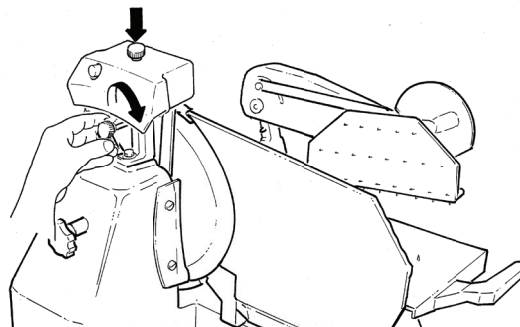

LUBRICATION

Carriage sliding guides product grip (once a week). Use only the oil provided; otherwise use white Vaseline oil. **DO NOT USE VEGETABLE OILS.**

Maintenance

- Spread a small quantity of oil on the bar and move the assembly 3 or 4 times;

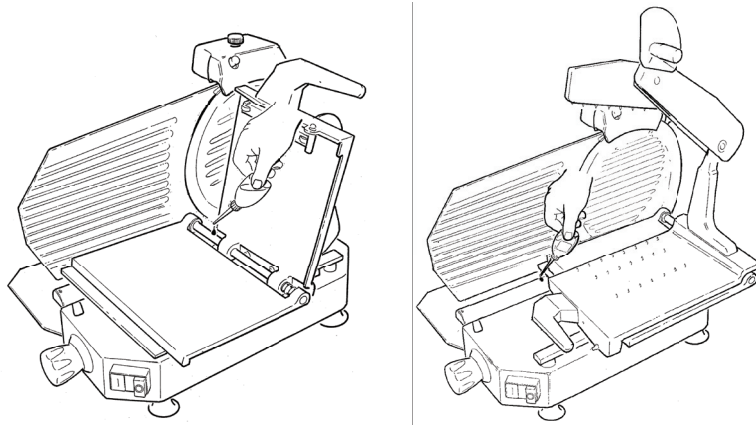

- Clean as required to remove excess of oil.

ADJUSTMENT OF MOTOR BELT TENSION

After a given period of service an unusual noise may occur because of the belt bedding. In this case, tighten the belt-stretcher on the side of the motor under the machine base.

- Disconnect the plug from the mains;
- Lift the machine and turn it on one side as shown in the picture;
- Unscrew the feet (1), unloose the screw (2) and remove the guard (3);
- Partially unscrew the nut (4);
- Turn the belt-stretcher (5) until the optimal tension of the belt is obtained (6);
- Tighten the nut (4) and install the guard (3), the screw (2) and the feet (1).

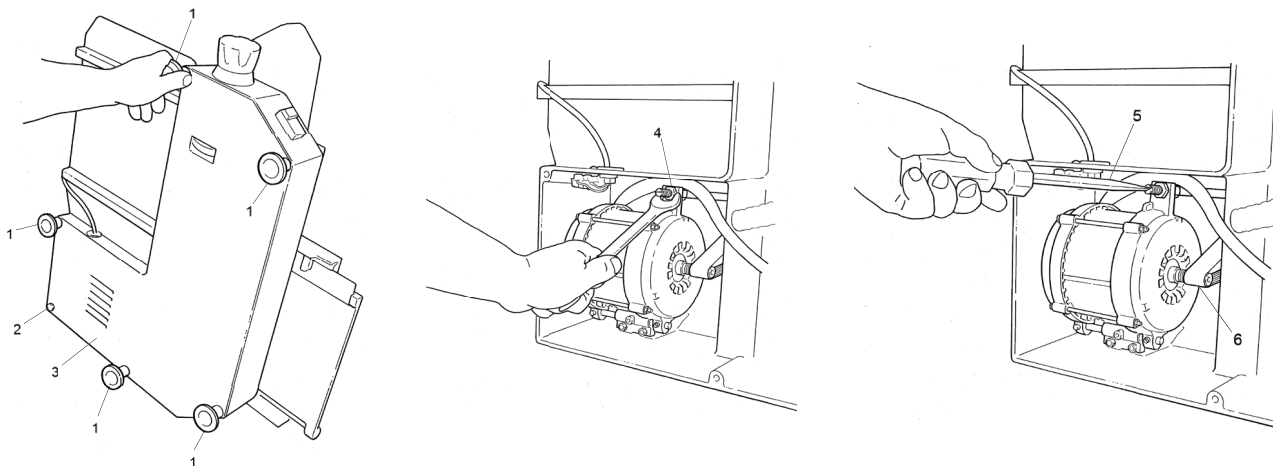

Troubleshooting

The table below indicates the most common problems that may arise during slicing and the necessary remedies.

PROBLEM	POSSIBLE CAUSE	REMEDY
The machine does not start when the start-up button (white or green button) is pressed or switch is turned.	No power supply.	Ascertain that the plug is correctly inserted.
	Defective electrical control circuit.	Check.
		Call technical assistance.
The machine starts, but the functioning light is not on.	Defective indicator.	Do not use the machine when the pilot lamp is not on; promptly ask for technical assistance.
The machine starts, but there are vibrations. The motor is very hot and there is a bad smell.	Defective motor or transmission.	Do not use the machine; promptly ask for technical assistance.
Under strain, the machine slows down or comes to a stop.	Defective transmission.	Ask for technical assistance.
Excessive resistance to product slicing.	The blade is blunt .	Sharpen the blade.
The slices are ragged and/or shaped irregularly.	The blade is blunt.	Sharpen the blade.
	The blade is excessively worn out.	Ask for technical assistance.
Unsatisfactory blade sharpening.	Worn wheels.	Replace the wheels.
		Ask for technical assistance.
The product tray doesn't slide.	Guides are insufficiently lubricated.	Lubricate.
When the stop button is pressed or turned, the machine does not stop.	Defective electrical control circuit.	Stop the machine, unplug from mains and ask for technical assistance.
Unusual noise of transmission.	Loose belt.	Adjust belt tension.

DISMANTLING THE SLICER

These machines are made of the following elements:

- Aluminium frame;
- Stainless steel fittings and others;
- Electrical parts and cords;
- Electrical motor;
- Plastic materials, etc.

Whether dismantling is entrusted to third parties please note that disposal of the materials can only be carried

Troubleshooting

out by duly authorized businesses. Whether dismantling done in-house it is necessary to separate materials according to their category, entrusting disposal skilled and authorised companies. In any case, please comply to the current norms of your country.

WARNING

In any case, to remove the blade and dispose of it, you must contact the manufacturer or personnel duly authorized by the manufacturer. **NEVER DISPOSE OF WASTE IN AREAS WHERE ACCESS IS NOT DELIMITED BY BARRIERS AND FORBIDDEN BY WARNING SIGNS AS THIS WASTE REPRESENTS A SERIOUS DANGER FOR PEOPLE, ESPECIALLY FOR CHILDREN, AND ANIMALS. ANY RESPONSIBILITY ARISING OUT OF INCORRECT DISPOSAL FALLS ON THE OWNER.**

Guide to the treatment of waste equipment

This product complied with Directive 2002/96 /EC.



The crossed out wheeled bin symbol on equipment or its packaging indicates that at the end of its working life the equipment should not be treated as general household waste but taken to one of the recycling centres for electrical and electronic equipment run by local authorities. Alternatively, it may be handed over to the reseller when purchasing new equipment of the same type. The user is responsible for consigning the equipment to appropriate collection facilities at the end of its working life or face the penalties provided for by current waste management legislation. Separate collection for subsequent delivery of waste equipment to environmentally-compatible recycling, treatment and disposal facilities to prevent possible negative impacts on the environment and human health whilst encouraging recycling of the product's components. For further information regarding the available collection facilities, please contact your local refuse collection service or the dealer from whom the purchase was made. The manufacturer and/or importer fulfil their obligations concerning environmentally-compatible recycling, treatment and disposal either individually or by joining a collective scheme.

For parts or service call 1-800-465-0234.

REFERENCE

Item Number	Model Number	Description	Manufacturer Model Number
13647	MS-IT-0300-V	Meat Slicer Belt Driven Horizontal 12" / 300mm Blade 0.5 HP / 373 W 110V/60/1	300TCV
13648	MS-IT-0330-V	Meat Slicer Belt Driven Horizontal 13" / 330mm Blade 0.5 HP / 373 W 110V/60/1	330TCV
13649	MS-IT-0350-V	Meat Slicer Belt Driven Horizontal 14" / 350mm Blade 0.5 HP / 373 W 110V/60/1	350TCV
13650	MS-IT-0370-V	Meat Slicer Belt Driven Horizontal 15" / 370mm Blade 0.5 HP / 373 W 110V/60/1	370TCV

Parts Breakdown

Model MS-IT-0300-V 13647
Model MS-IT-0330-V 13648
Model MS-IT-0350-V 13649
Model MS-IT-0370-V 13650

Stand

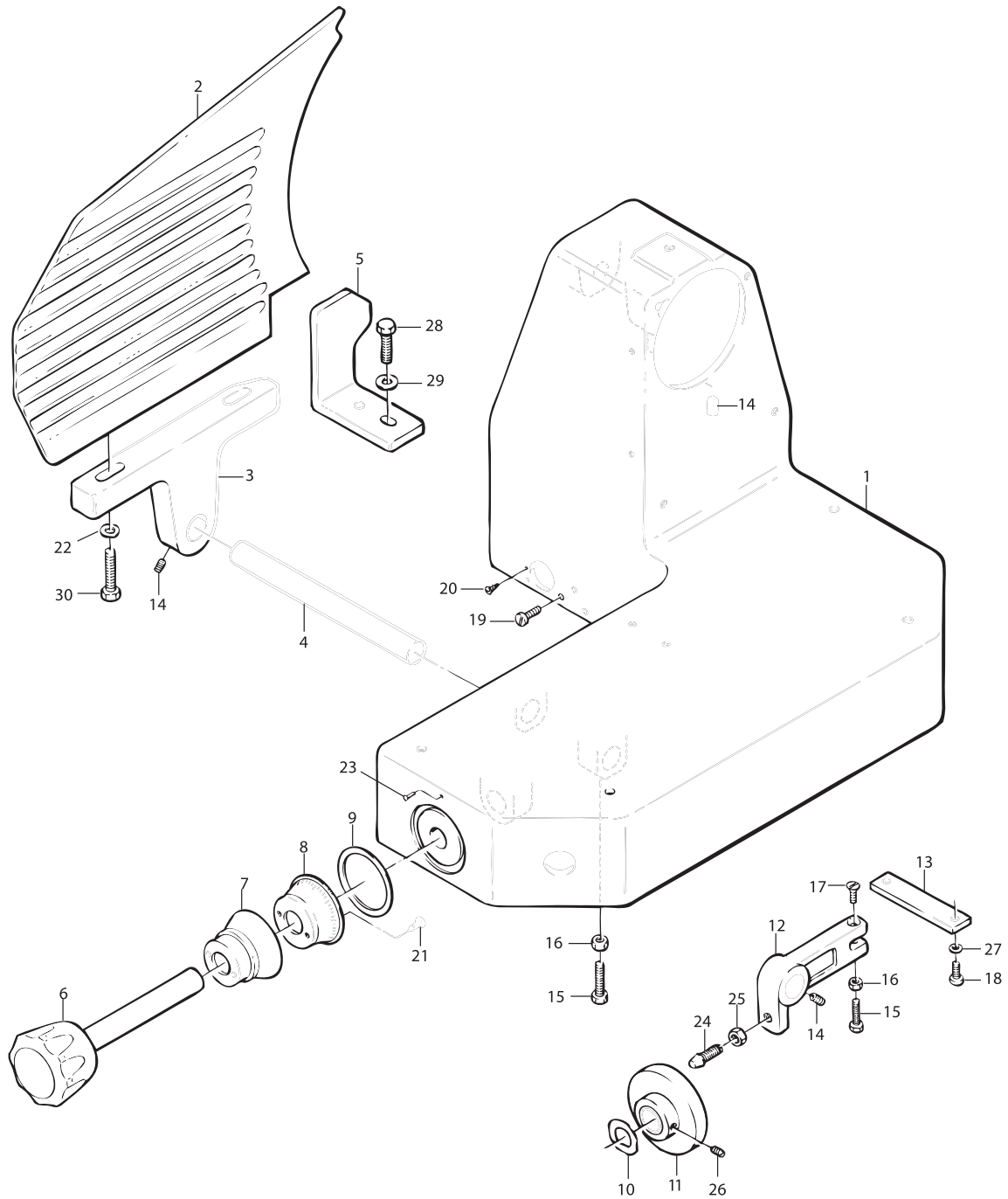

Parts Breakdown

Model MS-IT-0300-V 13647

Model MS-IT-0330-V 13648

Model MS-IT-0350-V 13649

Model MS-IT-0370-V 13650

Guide

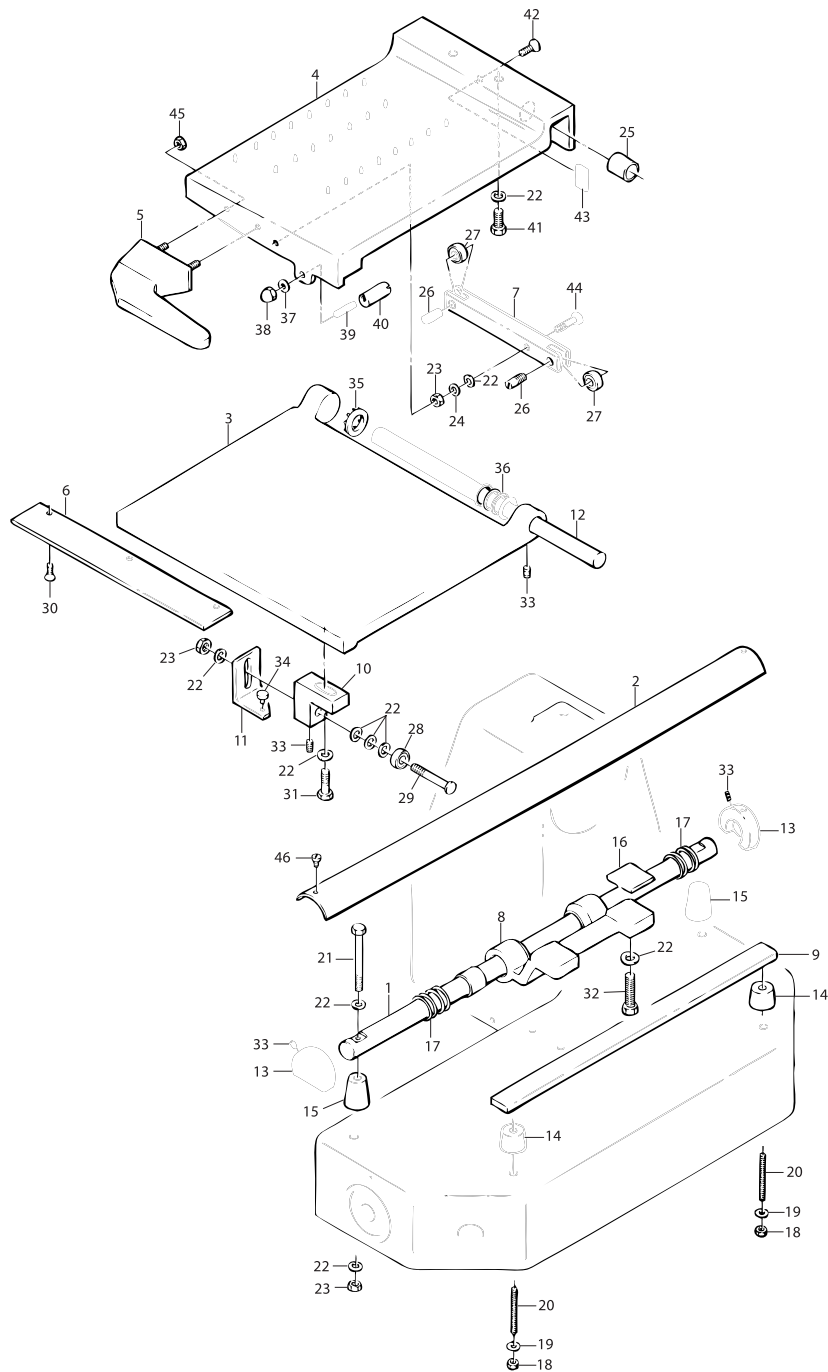

Parts Breakdown

Model MS-IT-0300-V 13647
Model MS-IT-0330-V 13648
Model MS-IT-0350-V 13649
Model MS-IT-0370-V 13650

Blade Assembly

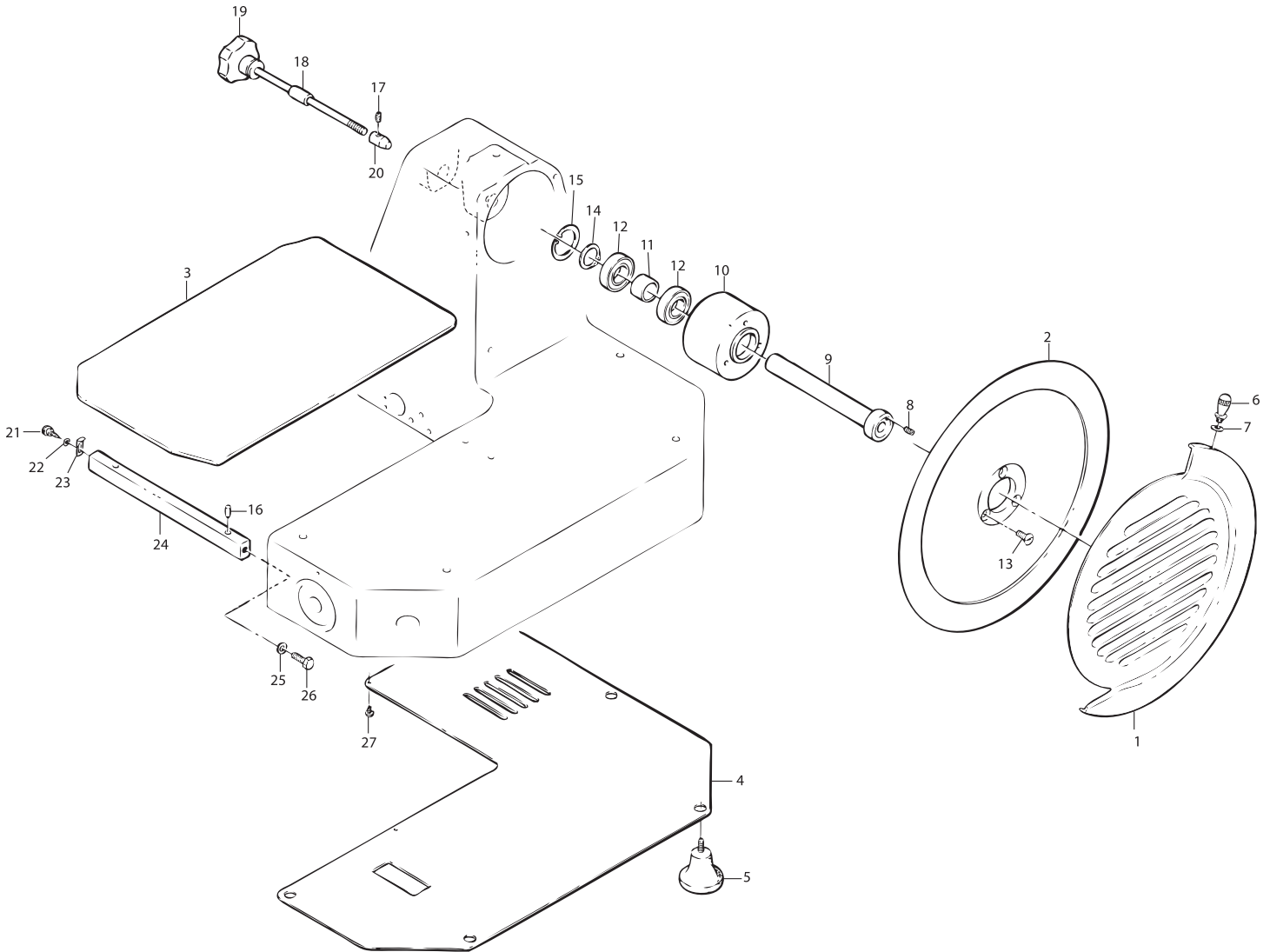

Parts Breakdown

Model MS-IT-0300-V 13647
Model MS-IT-0330-V 13648
Model MS-IT-0350-V 13649
Model MS-IT-0370-V 13650

Meat Tray Assembly

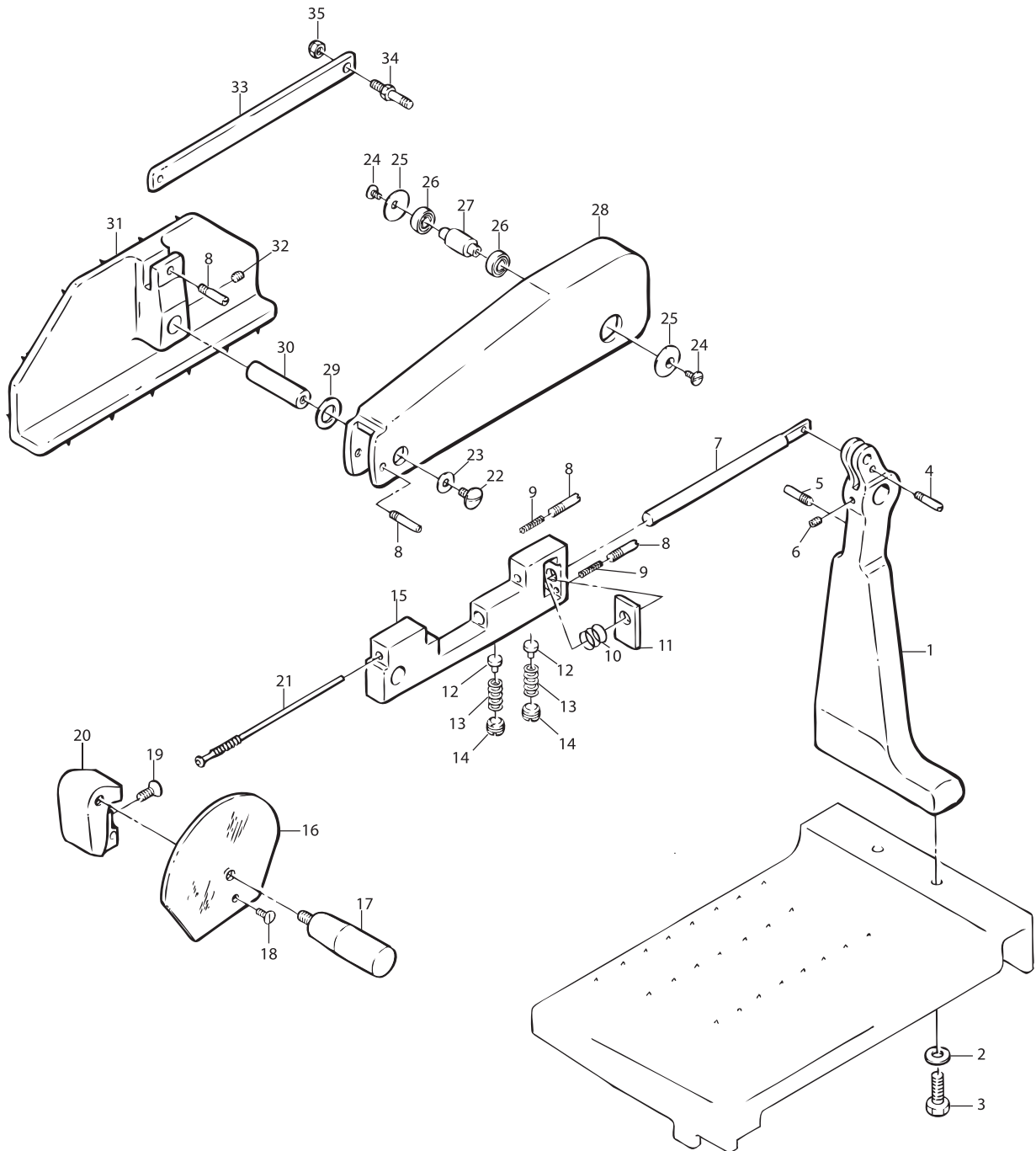

Parts Breakdown

Model MS-IT-0300-V 13647
Model MS-IT-0330-V 13648
Model MS-IT-0350-V 13649
Model MS-IT-0370-V 13650

Blade Guard

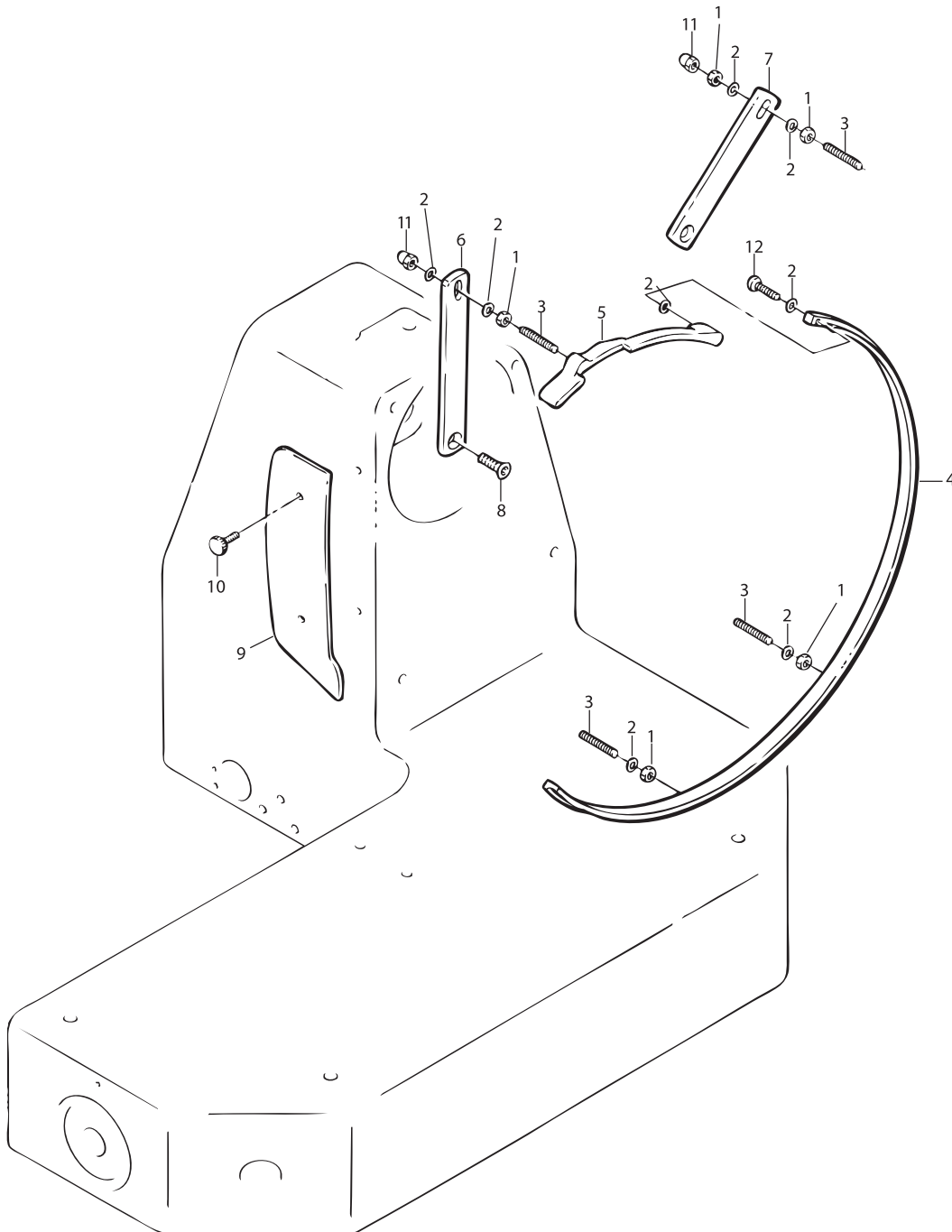

Parts Breakdown

Model MS-IT-0300-V 13647
Model MS-IT-0330-V 13648
Model MS-IT-0350-V 13649
Model MS-IT-0370-V 13650

Sharpening Assembly

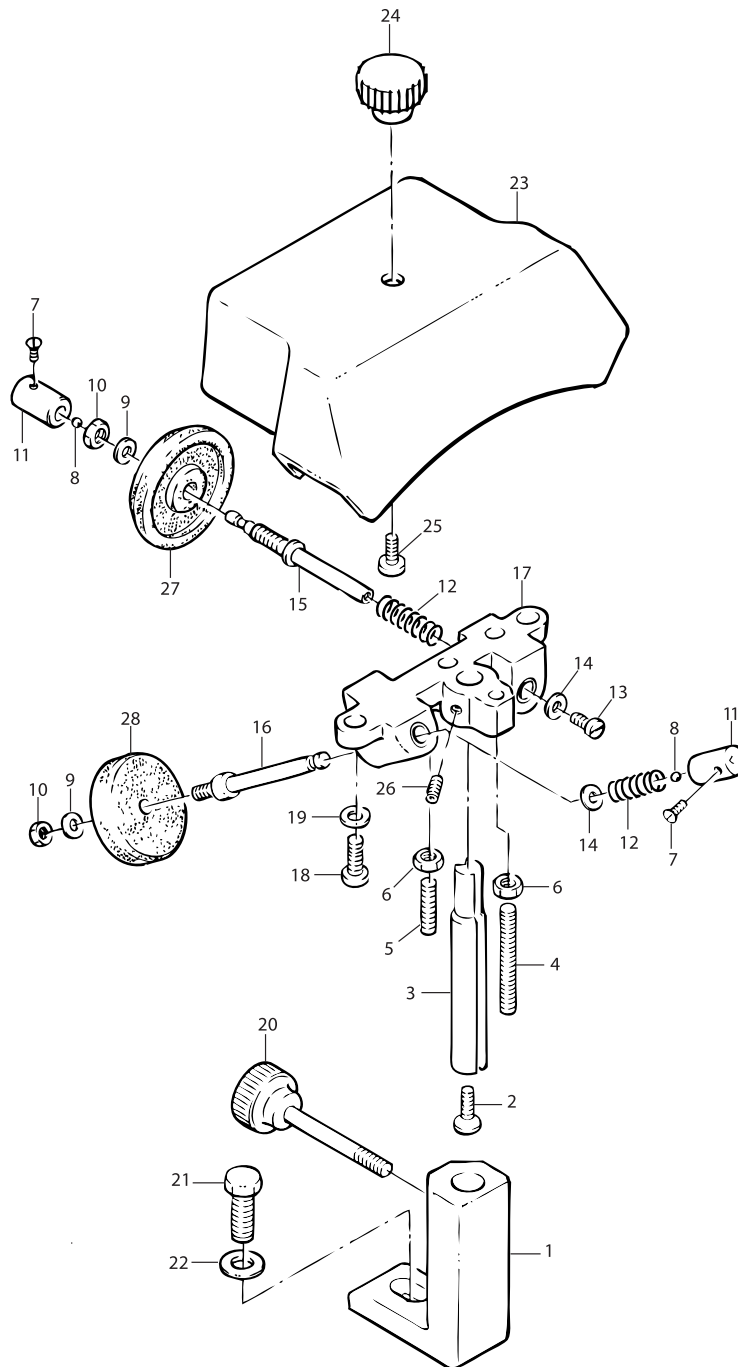

Parts Breakdown

Model MS-IT-0300-V 13647
Model MS-IT-0330-V 13648
Model MS-IT-0350-V 13649
Model MS-IT-0370-V 13650

Food Tray Assembly

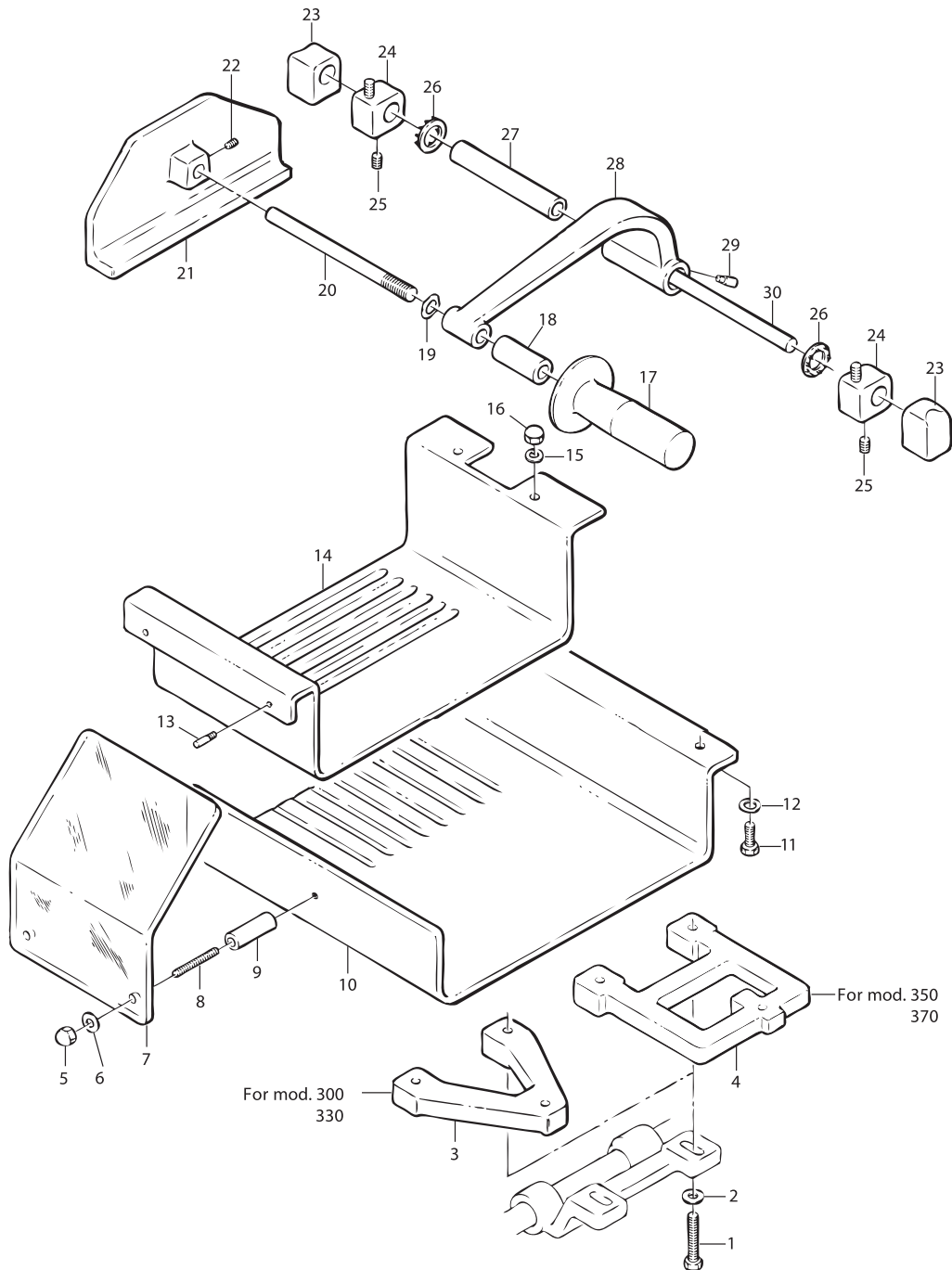



Parts Breakdown

Model MS-IT-0300-V 13647

Stand

Item No.	Description	Position	Item No.	Description	Position	Item No.	Description	Position
31881	Housing for 300TCV	1	31892	Cam Plate for 300TCV	13	31902	Set Screw - Capped for 300TCV	24
31882	Guide Plate for 300TCV	2	31893	Set Screw 8x10 TC for 300TCV	14	31903	Nut 8 for 300TCV	25
31883	Guide Plate Support for 300TCV	3	31894	Bolt 5x20 for 300TCV	15	31904	Set Screw 6x8 TP for 300TCV	26
31884	Guide Plate Shaft for 300TCV	4	31895	Nut 5 for 300TCV	16	31905	Washer 5 for 300TCV	27
31885	Bracket for 300TCV	5	31896	Screw TPSV 5x10 for 300TCV	17	31906	Screw TE 6x12 for 300TCV	28
17865	Index Knob for 300TCV	6 - 8, 21	31897	Screw TC 5x10 for 300TCV	18	31907	Washer 6 for 300TCV	29
31887	Index Knob Bushing for 300TCV	9	31898	Screw TE 6x12 for 300TCV	19	31908	Screw TE 8x40 for 300TCV	30
31888	Wavy Washer for 300TCV	10	31899	Tapping Screw 2.9x12 for 300TCV	20	31891	Cam Assembly for 300TCV	
17851	Cam for 300TCV	11	31900	Washer 8 for 300TCV	22			
31890	Cam Guide for 300TCV	12	31901	Copper Rivet for 300TCV	23			

Guide

Item No.	Description	Position	Item No.	Description	Position	Item No.	Description	Position
31909	Carriage Slide Bar for 300TCV	1	31925	Slide Bar Spring for 300TCV	17	31941	Set Screw 5x8 TC for 300TCV	33
31910	Slide Bar Cover for 300TCV	2	31926	Nut 6 for 300TCV	18	31942	Set Screw PVC for 300TCV	34
31911	Bottom Plate for 300TCV	3	31927	Washer 6 for 300TCV	19	31943	Rubber Washer 15 for 300TCV	35
31912	Top Plate for 300TCV	4	31928	Set Screw 6x30 for 300TCV	20	31944	Carriage Plate Spring for 300TCV	36
17863	Carriage Handle for 300TCV	5	31929	Screw TE 8x40 for 300TCV	21	31945	Washer 5 for 300TCV	37
31914	Flat Bar for 300TCV	6	31930	Washer 8 for 300TCV	22	31946	Acorn Cap for 300TCV	38
31915	Bearing Support Bar for 300TCV	7	31931	Nut 8 for 300TCV	23	31947	Set Screw 5x20 TP for 300TCV	39
31916	Carriage Support for 300TCV	8	31932	Washer 8 for 300TCV	24	31948	Set Screw PVC for 300TCV	40
31917	Carriage Rail for 300TCV	9	31933	Bushing for 300TCV	25	31949	Screw TE 8x20 for 300TCV	41
31918	Bracket for 300TCV	10	31934	Set Screw 6x12 for 300TCV	26	31950	Screw TPSV 4x10 for 300TCV	42
31919	Plate Bracket for 300TCV	11	31935	Bearing 626 for 300TCV	27	31951	Flat Latch for 300TCV	43
31920	Carriage Plate Rod for 300TCV	12	31936	Bearing 608 for 300TCV	28	31952	Threaded Stud 8 for 300TCV	44
31921	Slide Bar Cap for 300TCV	13	31937	Bearing Pin 8 for 300TCV	29	31953	Nut 6 for 300TCV	45
31922	Rail Support for 300TCV	14	31938	Screw TPSV 5x10 for 300TCV	30	31954	Screw TC 4x5 for 300TCV	46
31923	Slide Bar Support for 300TCV	15	31939	Screw TE 8x20 for 300TCV	31			
31924	Spacer Plate for 300TCV	16	31940	Screw TE 8x25 for 300TCV	32			

Parts Breakdown

Model MS-IT-0300-V 13647

Blade Assembly

Item No.	Description	Position	Item No.	Description	Position	Item No.	Description	Position
15182	Blade Shield for 300TCV	1	31964	Pulley for 300TCV	10	31973	Tie Rod Spacer for 300TCV	20
31956	Blade for 300TCV	2	31965	Bearing Spacer for 300TCV	11	31974	Thumb Screw for 300TCV	21
31957	Aluminum Plate for 300TCV	3	31966	Bearing 6004 2RS for 300TCV	12	31975	Washer for 300TCV	22
31958	Bottom Cover for 300TCV	4	31967	Clip for 300TCV	14	31976	Plate Stop for 300TCV	23
31959	Foot for 300TCV	5	31968	Clip for 300TCV	15	31977	Support Rail for 300TCV	24
31960	Blade Shield Knob Screw for 300TCV	6	31969	Set Screw for 300TCV	16	31978	Washer 8 for 300TCV	25
31961	Washer 4 for 300TCV	7	31970	Set Screw 6x8 TC for 300TCV	17	31979	Screw TE 8x20 for 300TCV	26
31962	Set Screw 5x8 TP for 300TCV	8	31971	Set Screw PVC for 300TCV	18	31980	Tapping Screw for 300TCV	27
31963	Bearing and Shaft for 300TCV	9	31972	Tie Rod for 300TCV	19			

Meat Tray Assembly

Item No.	Description	Position	Item No.	Description	Position	Item No.	Description	Position
31981	Support for Pusher Arm for 300TCV	1	31993	Spring 9x15 for 300TCV	13	32005	Washer 4x25 for 300TCV	25
31982	Washer 8 for 300TCV	2	31994	Stud Brake for 300TCV	14	32006	Bearing 608 ZZ for 300TCV	26
31983	Screw TE 8x20 for 300TCV	3	31995	Presser Brake for 300TCV	15	32007	Bearing Spindle for 300TCV	27
31984	Set Screw 5x20 for 300TCV	4	31996	Hand Grip Safety Guard for 300TCV	16	32008	Pusher Arm for 300TCV	28
31985	Set Screw 5x16 for 300TCV	5	17862	Meat Grip Handle for 300TCV	17	32009	PVC Washer 15x25 for 300TCV	29
31986	Set Screw 6x8 TC for 300TCV	6	31998	Screw TPSV 4x10 for 300TCV	18	32010	Presser Spacer for 300TCV	30
31987	Rod Brake for 300TCV	7	31999	Screw TPSV 45x12 for 300TCV	19	32011	Presser Plate for 300TCV	31
31988	Set Screw 6x19 for 300TCV	8	32000	Presser Handle Bracket for 300TCV	20	32012	Set Screw 6x6 TC for 300TCV	32
31989	Spring 3.5x19 for 300TCV	9	32001	Rod and Spring for 300TCV	21	32013	Presser Shaft for 300TCV	33
31990	Spring 13.5x10 for 300TCV	10	32002	Screw Chrome for 300TCV	22	32014	Hex Pin 8x31 for 300TCV	34
31991	Iron Plate for 300TCV	11	32003	Washer 8 for 300TCV	23	32015	Locking Nut for 300TCV	35
31992	Brake Stud for 300TCV	12	32004	Screw TPSV 4x10 for 300TCV	24	32016	Complete Arm Assembly for 300TCV	

Blade Guard

Item No.	Description	Position	Item No.	Description	Position	Item No.	Description	Position
32017	Nut 5 for 300TCV	1	32021	Safety Ring Extension for 300TCV	5	32025	Meat Deflector for 300TCV	9
32018	Washer 5 for 300TCV	2	32022	Support Ring for 300TCV	6	32026	Thumb Screw 5 MA for 300TCV	10
32019	Set Screw 54x30 / 5x25 for 300TCV	3	32023	Support Ring for 300TCV	7	32027	Acorn Cap for 300TCV	11
32020	Ring for 300TCV	4	32024	Set Screw 6x12 for 300TCV	8			

Parts Breakdown

Model MS-IT-0300-V 13647

Electrical Components

Item No.	Description	Position	Item No.	Description	Position	Item No.	Description	Position
17861	Capacitor for 300TCV	1	14859	Power Cord for 300TCV	11	32040	Motor Hinge for 300TCV	18
32029	Capacitor Bracket for 300TCV	2	32035	Wing Nut for 300TCV	12	32041	Set Screw 5x8 TC for 300TCV	19
32030	Washer 5 for 300TCV	3	32036	Washer 6A Wide for 300TCV	13	32042	Screw TC 4x10 for 300TCV	20
32031	Screw 5x10 TC for 300TCV	4	32037	Motor Bracket for 300TCV	14	32043	Terminal Block for 300TCV	21
32032	Switch - On / Off for 300TCV	5 - 7	32038	Adjustment Rod for 300TCV	15	32044	Tapping Screw for 300TCV	22
17866	Motor for 300TCV	9 - 11, 16	32039	Motor Support Shaft for 300TCV	17	32045	Stop Plate for 300TCV	23

Sharpening Assembly

Item No.	Description	Position	Item No.	Description	Position	Item No.	Description	Position
32046	Sharpener Support Bracket for 300TCV	1	32056	Sharpener Push Button for 300TCV	11	32066	Screw TE 8x20 for 300TCV	21
32047	Screw TPSV 6x12 for 300TCV	2	32057	Spring for 300TCV	12	32067	Washer 8 for 300TCV	22
32048	Shaft for Sharpener for 300TCV	3	32058	Screw TC for 300TCV	13	32068	Sharpener Cover for 300TCV	23
32049	Set Screw 5x40 for 300TCV	4	32059	Washer 3 for 300TCV	14	32069	Sharpener Cover Knob for 300TCV	24
32050	Set Screw 5x30 for 300TCV	5	32060	Sharpener Pin for 300TCV	15	32070	Screw TC 6x12 for 300TCV	25
32051	Nut 6 for 300TCV	6	32061	Sharpener Pin for 300TCV	16	32071	Set Screw 6x8 TC for 300TCV	26
32052	Sharpener Screw for 300TCV	7	32062	Sharpener Body for 300TCV	17	33032	Finishing Stone for 300TCV	27
32053	Ball Bearing for 300TCV	8	32063	Screw TC 4x20 for 300TCV	18	18016	Grinding Stone for 300TCV	28
32054	Washer 6 for 300TCV	9	32064	Washer 4 for 300TCV	19	15156	Complete Sharpening Assy for 300TCV	
32055	Nut 6 for 300TCV	10	32065	Sharpener Tie Rod for 300TCV	20			

Food Tray Assembly

Item No.	Description	Position	Item No.	Description	Position	Item No.	Description	Position
32073	Screw TE 8x35 for 300TCV	1	32083	Screw TE 8x20 for 300TCV	11	32093	Presser Plate for 300TCV	21
32074	Washer 8 for 300TCV	2	32084	Washer 8 for 300TCV	12	32094	Set Screw 6x8 TC for 300TCV	22
32075	Carriage Plate Support V for 300TCV	3	32085	Stud 5 MA for 300TCV	13	32095	End Block for 300TCV	23
32076	Carriage Plate Support H for 300TCV	4	32086	Carriage Plate - Small for 300TCV	14	32096	Inside Block for 300TCV	24
32077	Nut for 300TCV	5	32087	Washer 6x18 for 300TCV	15	32097	Set Screw 6x8 TC for 300TCV	25
32078	Washer 6x18 for 300TCV	6	32088	Nut 6 for 300TCV	16	32098	Rubber Washer for 300TCV	26
17860	Carriage Safety Guard for 300TCV	7	32089	Meat Grip Handle for 300TCV	17	32099	Spacer for 300TCV	27
32080	Stud 6x50 for 300TCV	8	32090	Aluminum Spacer for 300TCV	18	32100	Bracket for 300TCV	28
32081	Spacer for 300TCV	9	32091	Wavy Washer for 300TCV	19	32101	Stud PVC for 300TCV	29
32082	Carriage Plate - Large for 300TCV	10	32092	Stud 12 MA for 300TCV	20	32102	Presser Rod for 300TCV	30

Parts Breakdown

Model MS-IT-0330-V 13648

Stand

Item No.	Description	Position	Item No.	Description	Position	Item No.	Description	Position
32103	Housing for 330TCV	1	32114	Cam Plate for 330TCV	13	32124	Set Screw - Capped for 330TCV	24
32104	Guide Plate for 330TCV	2	32115	Set Screw 8x10 TC for 330TCV	14	32125	Nut 8 for 330TCV	25
32105	Guide Plate Support for 330TCV	3	32116	Bolt 5x20 for 330TCV	15	32126	Set Screw 6x8 TP for 330TCV	26
32106	Guide Plate Shaft for 330TCV	4	32117	Nut 5 for 330TCV	16	32127	Washer 5 for 330TCV	27
32107	Bracket for 330TCV	5	32118	Screw TPSV 5x10 for 330TCV	17	32128	Screw TE 6x12 for 330TCV	28
32108	Index Knob for 330TCV	6 - 8, 21	32119	Screw TC 5x10 for 330TCV	18	32129	Washer 6 for 330TCV	29
32109	Index Knob Bushing for 330TCV	9	32120	Screw TE 6x12 for 330TCV	19	32130	Screw TE 8x40 for 330TCV	30
32110	Wavy Washer for 330TCV	10	32121	Tapping Screw 2.9x12 for 330TCV	20	32113	Cam Assembly for 330TCV	
32111	Cam for 330TCV	11	32122	Washer 8 for 330TCV	22			
32112	Cam Guide for 330TCV	12	32123	Copper Rivet for 330TCV	23			

Guide

Item No.	Description	Position	Item No.	Description	Position	Item No.	Description	Position
32131	Carriage Slide Bar for 330TCV	1	32147	Slide Bar Spring for 330TCV	17	32163	Set Screw 5x8 TC for 330TCV	33
32132	Slide Bar Cover for 330TCV	2	32148	Nut 6 for 330TCV	18	32164	Set Screw PVC for 330TCV	34
32133	Bottom Plate for 330TCV	3	32149	Washer 6 for 330TCV	19	32165	Rubber Washer 15 for 330TCV	35
32134	Top Plate for 330TCV	4	32150	Set Screw 6x30 for 330TCV	20	32166	Carriage Plate Spring for 330TCV	36
32135	Carriage Handle for 330TCV	5	32151	Screw TE 8x40 for 330TCV	21	32167	Washer 5 for 330TCV	37
32136	Flat Bar for 330TCV	6	32152	Washer 8 for 330TCV	22	32168	Acorn Cap for 330TCV	38
32137	Bearing Support Bar for 330TCV	7	32153	Nut 8 for 330TCV	23	32169	Set Screw 5x20 TP for 330TCV	39
32138	Carriage Support for 330TCV	8	32154	Washer 8 for 330TCV	24	32170	Set Screw PVC for 330TCV	40
32139	Carriage Rail for 330TCV	9	32155	Bushing for 330TCV	25	32171	Screw TE 8x20 for 330TCV	41
32140	Bracket for 330TCV	10	32156	Set Screw 6x12 for 330TCV	26	32172	Screw TPSV 4x10 for 330TCV	42
32141	Plate Bracket for 330TCV	11	32157	Bearing 626 for 330TCV	27	32173	Flat Latch for 330TCV	43
32142	Carriage Plate Rod for 330TCV	12	32158	Bearing 608 for 330TCV	28	32174	Threaded Stud 8 for 330TCV	44
32143	Slide Bar Cap for 330TCV	13	32159	Bearing Pin 8 for 330TCV	29	32175	Nut 6 for 330TCV	45
32144	Rail Support for 330TCV	14	32160	Screw TPSV 5x10 for 330TCV	30	32176	Screw TC 4x5 for 330TCV	46
32145	Slide Bar Support for 330TCV	15	32161	Screw TE 8x20 for 330TCV	31			
32146	Spacer Plate for 330TCV	16	32162	Screw TE 8x25 for 330TCV	32			

Parts Breakdown

Model MS-IT-0330-V 13648

Blade Assembly

Item No.	Description	Position	Item No.	Description	Position	Item No.	Description	Position
17857	Blade Shield for 330TCV	1	32186	Pulley for 330TCV	10	32195	Tie Rod Spacer for 330TCV	20
32178	Blade for 330TCV	2	32187	Bearing Spacer for 330TCV	11	32196	Thumb Screw for 330TCV	21
32179	Aluminum Plate for 330TCV	3	32188	Bearing 6004 2RS for 330TCV	12	32197	Washer for 330TCV	22
32180	Bottom Cover for 330TCV	4	32189	Clip for 330TCV	14	32198	Plate Stop for 330TCV	23
32181	Foot for 330TCV	5	32190	Clip for 330TCV	15	32199	Support Rail for 330TCV	24
32182	Blade Shield Knob Screw for 330TCV	6	32191	Set Screw for 330TCV	16	32200	Washer 8 for 330TCV	25
32183	Washer 4 for 330TCV	7	32192	Set Screw 6x8 TC for 330TCV	17	32201	Screw TE 8x20 for 330TCV	26
32184	Set Screw 5x8 TP for 330TCV	8	32193	Set Screw PVC for 330TCV	18	32202	Tapping Screw for 330TCV	27
32185	Bearing and Shaft for 330TCV	9	32194	Tie Rod for 330TCV	19			

Meat Tray Assembly

Item No.	Description	Position	Item No.	Description	Position	Item No.	Description	Position
32203	Support for Pusher Arm for 330TCV	1	32215	Spring 9x15 for 330TCV	13	32227	Washer 4x25 for 330TCV	25
32204	Washer 8 for 330TCV	2	32216	Stud Brake for 330TCV	14	32228	Bearing 608 ZZ for 330TCV	26
32205	Screw TE 8x20 for 330TCV	3	32217	Presser Brake for 330TCV	15	32229	Bearing Spindle for 330TCV	27
32206	Set Screw 5x20 for 330TCV	4	32218	Hand Grip Safety Guard for 330TCV	16	32230	Pusher Arm for 330TCV	28
32207	Set Screw 5x16 for 330TCV	5	32219	Meat Grip Handle for 330TCV	17	32231	PVC Washer 15x25 for 330TCV	29
32208	Set Screw 6x8 TC for 330TCV	6	32220	Screw TPSV 4x10 for 330TCV	18	32232	Presser Spacer for 330TCV	30
32209	Rod Brake for 330TCV	7	32221	Screw TPSV 45x12 for 330TCV	19	32233	Presser Plate for 330TCV	31
32210	Set Screw 6x19 for 330TCV	8	32222	Presser Handle Bracket for 330TCV	20	32234	Set Screw 6x6 TC for 330TCV	32
32211	Spring 3.5x19 for 330TCV	9	32223	Rod and Spring for 330TCV	21	32235	Presser Shaft for 330TCV	33
32212	Spring 13.5x10 for 330TCV	10	32224	Screw Chrome for 330TCV	22	32236	Hex Pin 8x31 for 330TCV	34
32213	Iron Plate for 330TCV	11	32225	Washer 8 for 330TCV	23	32237	Locking Nut for 330TCV	35
32214	Brake Stud for 330TCV	12	32226	Screw TPSV 4x10 for 330TCV	24	32238	Complete Arm Assembly for 330TCV	

Blade Guard

Item No.	Description	Position	Item No.	Description	Position	Item No.	Description	Position
32239	Nut 5 for 330TCV	1	32243	Safety Ring Extension for 330TCV	5	32247	Meat Deflector for 330TCV	9
32240	Washer 5 for 330TCV	2	32244	Support Ring for 330TCV	6	32248	Thumb Screw 5 MA for 330TCV	10
32241	Set Screw 5/4x30 / 5x25 for 330TCV	3	32245	Support Ring for 330TCV	7	32249	Acorn Cap for 330TCV	11
32242	Ring for 330TCV	4	32246	Set Screw 6x12 for 330TCV	8			

Parts Breakdown

Model MS-IT-0330-V 13648

Electrical Components

Item No.	Description	Position	Item No.	Description	Position	Item No.	Description	Position
32250	Capacitor for 330TCV	1	32256	Power Cord for 330TCV	11	32262	Motor Hinge for 330TCV	18
32251	Capacitor Bracket for 330TCV	2	32257	Wing Nut for 330TCV	12	32263	Set Screw 5x8 TC for 330TCV	19
32252	Washer 5 for 330TCV	3	32258	Washer 6A Wide for 330TCV	13	32264	Screw TC 4x10 for 330TCV	20
32253	Screw 5x10 TC for 330TCV	4	32259	Motor Bracket for 330TCV	14	32265	Terminal Block for 330TCV	21
32254	Switch - On / Off for 330TCV	5 - 7	32260	Adjustment Rod for 330TCV	15	32266	Tapping Screw for 330TCV	22
32255	Motor for 330TCV	9 - 11, 16	32261	Motor Support Shaft for 330TCV	17	32267	Stop Plate for 330TCV	23

Sharpening Assembly

Item No.	Description	Position	Item No.	Description	Position	Item No.	Description	Position
32268	Sharpener Support Bracket for 330TCV	1	32278	Sharpener Push Button for 330TCV	11	32288	Screw TE 8x20 for 330TCV	21
32269	Screw TPSV 6x12 for 330TCV	2	32279	Spring for 330TCV	12	32289	Washer 8 for 330TCV	22
32270	Shaft for Sharpener for 330TCV	3	32280	Screw TC for 330TCV	13	32290	Sharpener Cover for 330TCV	23
32271	Set Screw 5x40 for 330TCV	4	32281	Washer 3 for 330TCV	14	32291	Sharpener Cover Knob for 330TCV	24
32272	Set Screw 5x30 for 330TCV	5	32282	Sharpener Pin for 330TCV	15	32292	Screw TC 6x12 for 330TCV	25
32273	Nut 6 for 330TCV	6	32283	Sharpener Pin for 330TCV	16	32293	Set Screw 6x8 TC for 330TCV	26
32274	Sharpener Screw for 330TCV	7	32284	Sharpener Body for 330TCV	17	33032	Finishing Stone for 330TCV	27
32275	Ball Bearing for 330TCV	8	32285	Screw TC 4x20 for 330TCV	18	18016	Grinding Stone for 330TCV	28
32276	Washer 6 for 330TCV	9	32286	Washer 4 for 330TCV	19	15156	Complete Sharpening Assy for 330TCV	
32277	Nut 6 for 330TCV	10	32287	Sharpener Tie Rod for 330TCV	20			

Food Tray Assembly

Item No.	Description	Position	Item No.	Description	Position	Item No.	Description	Position
32295	Screw TE 8x35 for 330TCV	1	32305	Screw TE 8x20 for 330TCV	11	32315	Presser Plate for 330TCV	21
32296	Washer 8 for 330TCV	2	32306	Washer 8 for 330TCV	12	32316	Set Screw 6x8 TC for 330TCV	22
32297	Carriage Plate Support V for 330TCV	3	32307	Stud 5 MA for 330TCV	13	32317	End Block for 330TCV	23
32298	Carriage Plate Support H for 330TCV	4	32308	Carriage Plate - Small for 330TCV	14	32318	Inside Block for 330TCV	24
32299	Nut for 330TCV	5	32309	Washer 6x18 for 330TCV	15	32319	Set Screw 6x8 TC for 330TCV	25
32300	Washer 6x18 for 330TCV	6	32310	Nut 6 for 330TCV	16	32320	Rubber Washer for 330TCV	26
32301	Carriage Safety Guard for 330TCV	7	32311	Meat Grip Handle for 330TCV	17	32321	Spacer for 330TCV	27
32302	Stud 6x50 for 330TCV	8	32312	Aluminum Spacer for 330TCV	18	32322	Bracket for 330TCV	28
32303	Spacer for 330TCV	9	32313	Wavy Washer for 330TCV	19	32323	Stud PVC for 330TCV	29
32304	Carriage Plate - Large for 330TCV	10	32314	Stud 12 MA for 330TCV	20	32324	Presser Rod for 330TCV	30



Parts Breakdown

Model MS-IT-0350-V 13649

Stand

Item No.	Description	Position	Item No.	Description	Position	Item No.	Description	Position
32325	Housing for 350TCV	1	32336	Cam Plate for 350TCV	13	32346	Set Screw - Capped for 350TCV	24
32326	Guide Plate for 350TCV	2	32337	Set Screw 8x10 TC for 350TCV	14	32347	Nut 8 for 350TCV	25
32327	Guide Plate Support for 350TCV	3	32338	Bolt 5x20 for 350TCV	15	32348	Set Screw 6x8 TP for 350TCV	26
32328	Guide Plate Shaft for 350TCV	4	32339	Nut 5 for 350TCV	16	32349	Washer 5 for 350TCV	27
32329	Bracket for 350TCV	5	32340	Screw TPSV 5x10 for 350TCV	17	32350	Screw TE 6x12 for 350TCV	28
32330	Index Knob for 350TCV	6 - 8, 21	32341	Screw TC 5x10 for 350TCV	18	32351	Washer 6 for 350TCV	29
32331	Index Knob Bushing for 350TCV	9	32342	Screw TE 6x12 for 350TCV	19	32352	Screw TE 8x40 for 350TCV	30
32332	Wavy Washer for 350TCV	10	32343	Tapping Screw 2.9x12 for 350TCV	20	32335	Cam Assembly for 350TCV	
32333	Cam for 350TCV	11	32344	Washer 8 for 350TCV	22			
32334	Cam Guide for 350TCV	12	32345	Copper Rivet for 350TCV	23			

Guide

Item No.	Description	Position	Item No.	Description	Position	Item No.	Description	Position
32353	Carriage Slide Bar for 350TCV	1	32369	Slide Bar Spring for 350TCV	17	32385	Set Screw 5x8 TC for 350TCV	33
32354	Slide Bar Cover for 350TCV	2	32370	Nut 6 for 350TCV	18	32386	Set Screw PVC for 350TCV	34
32355	Bottom Plate for 350TCV	3	32371	Washer 6 for 350TCV	19	32387	Rubber Washer 15 for 350TCV	35
32356	Top Plate for 350TCV	4	32372	Set Screw 6x30 for 350TCV	20	32388	Carriage Plate Spring for 350TCV	36
32357	Carriage Handle for 350TCV	5	32373	Screw TE 8x40 for 350TCV	21	32389	Washer 5 for 350TCV	37
32358	Flat Bar for 350TCV	6	32374	Washer 8 for 350TCV	22	32390	Acorn Cap for 350TCV	38
32359	Bearing Support Bar for 350TCV	7	32375	Nut 8 for 350TCV	23	32391	Set Screw 5x20 TP for 350TCV	39
32360	Carriage Support for 350TCV	8	32376	Washer 8 for 350TCV	24	32392	Set Screw PVC for 350TCV	40
32361	Carriage Rail for 350TCV	9	32377	Bushing for 350TCV	25	32393	Screw TE 8x20 for 350TCV	41
32362	Bracket for 350TCV	10	32378	Set Screw 6x12 for 350TCV	26	32394	Screw TPSV 4x10 for 350TCV	42
32363	Plate Bracket for 350TCV	11	32379	Bearing 626 for 350TCV	27	32395	Flat Latch for 350TCV	43
32364	Carriage Plate Rod for 350TCV	12	32380	Bearing 608 for 350TCV	28	32396	Threaded Stud 8 for 350TCV	44
32365	Slide Bar Cap for 350TCV	13	32381	Bearing Pin 8 for 350TCV	29	32397	Nut 6 for 350TCV	45
32366	Rail Support for 350TCV	14	32382	Screw TPSV 5x10 for 350TCV	30	32398	Screw TC 4x5 for 350TCV	46
32367	Slide Bar Support for 350TCV	15	32383	Screw TE 8x20 for 350TCV	31			
32368	Spacer Plate for 350TCV	16	32384	Screw TE 8x25 for 350TCV	32			

Parts Breakdown

Model MS-IT-0350-V 13649

Blade Assembly

Item No.	Description	Position	Item No.	Description	Position	Item No.	Description	Position
17858	Blade Shield for 350TCV	1	32408	Pulley for 350TCV	10	32417	Tie Rod Spacer for 350TCV	20
13599	Blade for 350TCV	2	32409	Bearing Spacer for 350TCV	11	32418	Thumb Screw for 350TCV	21
32401	Aluminum Plate for 350TCV	3	32410	Bearing 6004 2RS for 350TCV	12	32419	Washer for 350TCV	22
32402	Bottom Cover for 350TCV	4	32411	Clip for 350TCV	14	32420	Plate Stop for 350TCV	23
32403	Foot for 350TCV	5	32412	Clip for 350TCV	15	32421	Support Rail for 350TCV	24
32404	Blade Shield Knob Screw for 350TCV	6	32413	Set Screw for 350TCV	16	32422	Washer 8 for 350TCV	25
32405	Washer 4 for 350TCV	7	32414	Set Screw 6x8 TC for 350TCV	17	32423	Screw TE 8x20 for 350TCV	26
32406	Set Screw 5x8 TP for 350TCV	8	32415	Set Screw PVC for 350TCV	18	32424	Tapping Screw for 350TCV	27
32407	Bearing and Shaft for 350TCV	9	32416	Tie Rod for 350TCV	19			

Meat Tray Assembly

Item No.	Description	Position	Item No.	Description	Position	Item No.	Description	Position
32425	Support for Pusher Arm for 350TCV	1	32437	Spring 9x15 for 350TCV	13	32449	Washer 4x25 for 350TCV	25
32426	Washer 8 for 350TCV	2	32438	Stud Brake for 350TCV	14	32450	Bearing 608 ZZ for 350TCV	26
32427	Screw TE 8x20 for 350TCV	3	32439	Presser Brake for 350TCV	15	32451	Bearing Spindle for 350TCV	27
32428	Set Screw 5x20 for 350TCV	4	32440	Hand Grip Safety Guard for 350TCV	16	32452	Pusher Arm for 350TCV	28
32429	Set Screw 5x16 for 350TCV	5	32441	Meat Grip Handle for 350TCV	17	32453	PVC Washer 15x25 for 350TCV	29
32430	Set Screw 6x8 TC for 350TCV	6	32442	Screw TPSV 4x10 for 350TCV	18	32454	Presser Spacer for 350TCV	30
32431	Rod Brake for 350TCV	7	32443	Screw TPSV 45x12 for 350TCV	19	32455	Presser Plate for 350TCV	31
32432	Set Screw 6x19 for 350TCV	8	32444	Presser Handle Bracket for 350TCV	20	32456	Set Screw 6x6 TC for 350TCV	32
32433	Spring 3.5x19 for 350TCV	9	32445	Rod and Spring for 350TCV	21	32457	Presser Shaft for 350TCV	33
32434	Spring 13.5x10 for 350TCV	10	32446	Screw Chrome for 350TCV	22	32458	Hex Pin 8x31 for 350TCV	34
32435	Iron Plate for 350TCV	11	32447	Washer 8 for 350TCV	23	32459	Locking Nut for 350TCV	35
32436	Brake Stud for 350TCV	12	32448	Screw TPSV 4x10 for 350TCV	24	32460	Complete Arm Assembly for 350TCV	

Blade Guard

Item No.	Description	Position	Item No.	Description	Position	Item No.	Description	Position
32461	Nut 5 for 350TCV	1	32465	Safety Ring Extension for 350TCV	5	32469	Meat Deflector for 350TCV	9
32462	Washer 5 for 350TCV	2	32466	Support Ring for 350TCV	6	32470	Thumb Screw 5 MA for 350TCV	10
32463	Set Screw 54x30 / 5x25 for 350TCV	3	32467	Support Ring for 350TCV	7	32471	Acorn Cap for 350TCV	11
32464	Ring for 350TCV	4	32468	Set Screw 6x12 for 350TCV	8			

Parts Breakdown

Model MS-IT-0350-V 13649

Electrical Components

Item No.	Description	Position	Item No.	Description	Position	Item No.	Description	Position
32472	Capacitor for 350TCV	1	32479	Wing Nut for 350TCV	12	32486	Screw TC 4x10 for 350TCV	20
32473	Capacitor Bracket for 350TCV	2	32480	Washer 6A Wide for 350TCV	13	32487	Terminal Block for 350TCV	21
32474	Washer 5 for 350TCV	3	32481	Motor Bracket for 350TCV	14	32488	Tapping Screw for 350TCV	22
32475	Screw 5x10 TC for 350TCV	4	32482	Adjustment Rod for 350TCV	15	32489	Stop Plate for 350TCV	23
32476	Switch - On / Off for 350TCV	5 - 7	32483	Motor Support Shaft for 350TCV	17	17855	Belt for 350TCV	
32477	Motor for 350TCV	9 - 11, 16	32484	Motor Hinge for 350TCV	18	17867	Motor for 350TCV	
14859	Power Cord for 350TCV	11	32485	Set Screw 5x8 TC for 350TCV	19			

Sharpening Assembly

Item No.	Description	Position	Item No.	Description	Position	Item No.	Description	Position
32490	Sharpener Support Bracket for 350TCV	1	32500	Sharpener Push Button for 350TCV	11	32510	Screw TE 8x20 for 350TCV	21
32491	Screw TPSV 6x12 for 350TCV	2	32501	Spring for 350TCV	12	32511	Washer 8 for 350TCV	22
32492	Shaft for Sharpener for 350TCV	3	32502	Screw TC for 350TCV	13	32512	Sharpener Cover for 350TCV	23
32493	Set Screw 5x40 for 350TCV	4	32503	Washer 3 for 350TCV	14	32513	Sharpener Cover Knob for 350TCV	24
32494	Set Screw 5x30 for 350TCV	5	32504	Sharpener Pin for 350TCV	15	32514	Screw TC 6x12 for 350TCV	25
32495	Nut 6 for 350TCV	6	32505	Sharpener Pin for 350TCV	16	32515	Set Screw 6x8 TC for 350TCV	26
32496	Sharpener Screw for 350TCV	7	32506	Sharpener Body for 350TCV	17	32516	Finishing Stone for 350TCV	27
32497	Ball Bearing for 350TCV	8	32507	Screw TC 4x20 for 350TCV	18	32738	Grinding Stone for 350TCV	28
32498	Washer 6 for 350TCV	9	32508	Washer 4 for 350TCV	19	64809	Complete Sharpening Assembly for 350TCV	
32499	Nut 6 for 350TCV	10	32509	Sharpener Tie Rod for 350TCV	20			

Food Tray Assembly

Item No.	Description	Position	Item No.	Description	Position	Item No.	Description	Position
32517	Screw TE 8x35 for 350TCV	1	32527	Screw TE 8x20 for 350TCV	11	32537	Presser Plate for 350TCV	21
32518	Washer 8 for 350TCV	2	32528	Washer 8 for 350TCV	12	32538	Set Screw 6x8 TC for 350TCV	22
32519	Carriage Plate Support V for 350TCV	3	32529	Stud 5 MA for 350TCV	13	32539	End Block for 350TCV	23
32520	Carriage Plate Support H for 350TCV	4	32530	Carriage Plate - Small for 350TCV	14	32540	Inside Block for 350TCV	24
32521	Nut for 350TCV	5	32531	Washer 6x18 for 350TCV	15	32541	Set Screw 6x8 TC for 350TCV	25
32522	Washer 6x18 for 350TCV	6	32532	Nut 6 for 350TCV	16	32542	Rubber Washer for 350TCV	26
32523	Carriage Safety Guard for 350TCV	7	32533	Meat Grip Handle for 350TCV	17	32543	Spacer for 350TCV	27
32524	Stud 6x50 for 350TCV	8	32534	Aluminum Spacer for 350TCV	18	32544	Bracket for 350TCV	28
32525	Spacer for 350TCV	9	32535	Wavy Washer for 350TCV	19	32545	Stud PVC for 350TCV	29
32526	Carriage Plate - Large for 350TCV	10	32536	Stud 12 MA for 350TCV	20	32546	Presser Rod for 350TCV	30

Parts Breakdown

Model MS-IT-0370-V 13650

Stand

Item No.	Description	Position	Item No.	Description	Position	Item No.	Description	Position
32547	Housing for 370TCV	1	32558	Cam Plate for 370TCV	13	32568	Set Screw - Capped for 370TCV	24
32548	Guide Plate for 370TCV	2	32559	Set Screw 8x10 TC for 370TCV	14	32569	Nut 8 for 370TCV	25
32549	Guide Plate Support for 370TCV	3	32560	Bolt 5x20 for 370TCV	15	32570	Set Screw 6x8 TP for 370TCV	26
32550	Guide Plate Shaft for 370TCV	4	32561	Nut 5 for 370TCV	16	32571	Washer 5 for 370TCV	27
32551	Bracket for 370TCV	5	32562	Screw TPSV 5x10 for 370TCV	17	32572	Screw TE 6x12 for 370TCV	28
32552	Index Knob for 370TCV	6 - 8, 21	32563	Screw TC 5x10 for 370TCV	18	32573	Washer 6 for 370TCV	29
32553	Index Knob Bushing for 370TCV	9	32564	Screw TE 6x12 for 370TCV	19	32574	Screw TE 8x40 for 370TCV	30
32554	Wavy Washer for 370TCV	10	32565	Tapping Screw 2.9x12 for 370TCV	20	32557	Cam Assembly for 370TCV	
32555	Cam for 370TCV	11	32566	Washer 8 for 370TCV	22			
32556	Cam Guide for 370TCV	12	32567	Copper Rivet for 370TCV	23			

Guide

Item No.	Description	Position	Item No.	Description	Position	Item No.	Description	Position
32575	Carriage Slide Bar for 370TCV	1	32591	Slide Bar Spring for 370TCV	17	32607	Set Screw 5x8 TC for 370TCV	33
32576	Slide Bar Cover for 370TCV	2	32592	Nut 6 for 370TCV	18	32608	Set Screw PVC for 370TCV	34
32577	Bottom Plate for 370TCV	3	32593	Washer 6 for 370TCV	19	32609	Rubber Washer 15 for 370TCV	35
32578	Top Plate for 370TCV	4	32594	Set Screw 6x30 for 370TCV	20	32610	Carriage Plate Spring for 370TCV	36
32579	Carriage Handle for 370TCV	5	32595	Screw TE 8x40 for 370TCV	21	32611	Washer 5 for 370TCV	37
32580	Flat Bar for 370TCV	6	32596	Washer 8 for 370TCV	22	32612	Acorn Cap for 370TCV	38
32581	Bearing Support Bar for 370TCV	7	32597	Nut 8 for 370TCV	23	32613	Set Screw 5x20 TP for 370TCV	39
32582	Carriage Support for 370TCV	8	32598	Washer 8 for 370TCV	24	32614	Set Screw PVC for 370TCV	40
32583	Carriage Rail for 370TCV	9	32599	Bushing for 370TCV	25	32615	Screw TE 8x20 for 370TCV	41
32584	Bracket for 370TCV	10	32600	Set Screw 6x12 for 370TCV	26	32616	Screw TPSV 4x10 for 370TCV	42
32585	Plate Bracket for 370TCV	11	32601	Bearing 626 for 370TCV	27	32617	Flat Latch for 370TCV	43
32586	Carriage Plate Rod for 370TCV	12	32602	Bearing 608 for 370TCV	28	32618	Threaded Stud 8 for 370TCV	44
32587	Slide Bar Cap for 370TCV	13	32603	Bearing Pin 8 for 370TCV	29	32619	Nut 6 for 370TCV	45
32588	Rail Support for 370TCV	14	32604	Screw TPSV 5x10 for 370TCV	30	32620	Screw TC 4x5 for 370TCV	46
32589	Slide Bar Support for 370TCV	15	32605	Screw TE 8x20 for 370TCV	31			
32590	Spacer Plate for 370TCV	16	32606	Screw TE 8x25 for 370TCV	32			

Parts Breakdown

Model MS-IT-0370-V 13650

Blade Assembly

Item No.	Description	Position	Item No.	Description	Position	Item No.	Description	Position
17859	Blade Shield for 370TCV	1	32630	Pulley for 370TCV	10	32639	Tie Rod Spacer for 370TCV	20
32622	Blade for 370TCV	2	32631	Bearing Spacer for 370TCV	11	32640	Thumb Screw for 370TCV	21
32623	Aluminum Plate for 370TCV	3	32632	Bearing 6004 2RS for 370TCV	12	32641	Washer for 370TCV	22
32624	Bottom Cover for 370TCV	4	32633	Clip for 370TCV	14	32642	Plate Stop for 370TCV	23
32625	Foot for 370TCV	5	32634	Clip for 370TCV	15	32643	Support Rail for 370TCV	24
32626	Blade Shield Knob Screw for 370TCV	6	32635	Set Screw for 370TCV	16	32644	Washer 8 for 370TCV	25
32627	Washer 4 for 370TCV	7	32636	Set Screw 6x8 TC for 370TCV	17	32645	Screw TE 8x20 for 370TCV	26
32628	Set Screw 5x8 TP for 370TCV	8	32637	Set Screw PVC for 370TCV	18	32646	Tapping Screw for 370TCV	27
32629	Bearing and Shaft for 370TCV	9	32638	Tie Rod for 370TCV	19			

Meat Tray Assembly

Item No.	Description	Position	Item No.	Description	Position	Item No.	Description	Position
32647	Support for Pusher Arm for 370TCV	1	32659	Spring 9x15 for 370TCV	13	32671	Washer 4x25 for 370TCV	25
32648	Washer 8 for 370TCV	2	32660	Stud Brake for 370TCV	14	32672	Bearing 608 ZZ for 370TCV	26
32649	Screw TE 8x20 for 370TCV	3	32661	Presser Brake for 370TCV	15	32673	Bearing Spindle for 370TCV	27
32650	Set Screw 5x20 for 370TCV	4	32662	Hand Grip Safety Guard for 370TCV	16	32674	Pusher Arm for 370TCV	28
32651	Set Screw 5x16 for 370TCV	5	32663	Meat Grip Handle for 370TCV	17	32675	PVC Washer 15x25 for 370TCV	29
32652	Set Screw 6x8 TC for 370TCV	6	32664	Screw TPSV 4x10 for 370TCV	18	32676	Presser Spacer for 370TCV	30
32653	Rod Brake for 370TCV	7	32665	Screw TPSV 45x12 for 370TCV	19	32677	Presser Plate for 370TCV	31
32654	Set Screw 6x19 for 370TCV	8	32666	Presser Handle Bracket for 370TCV	20	32678	Set Screw 6x6 TC for 370TCV	32
32655	Spring 3.5x19 for 370TCV	9	32667	Rod and Spring for 370TCV	21	32679	Presser Shaft for 370TCV	33
32656	Spring 13.5x10 for 370TCV	10	32668	Screw Chrome for 370TCV	22	32680	Hex Pin 8x31 for 370TCV	34
32657	Iron Plate for 370TCV	11	32669	Washer 8 for 370TCV	23	32681	Locking Nut for 370TCV	35
32658	Brake Stud for 370TCV	12	32670	Screw TPSV 4x10 for 370TCV	24	32682	Complete Arm Assembly for 370TCV	

Blade Guard

Item No.	Description	Position	Item No.	Description	Position	Item No.	Description	Position
32683	Nut 5 for 370TCV	1	32687	Safety Ring Extension for 370TCV	5	32691	Meat Deflector for 370TCV	9
32684	Washer 5 for 370TCV	2	32688	Support Ring for 370TCV	6	32692	Thumb Screw 5 MA for 370TCV	10
32685	Set Screw 54x30 / 5x25 for 370TCV	3	32689	Support Ring for 370TCV	7	32693	Acorn Cap for 370TCV	11
32686	Ring for 370TCV	4	32690	Set Screw 6x12 for 370TCV	8			

Parts Breakdown

Model MS-IT-0370-V 13650

Electrical Components

Item No.	Description	Position	Item No.	Description	Position	Item No.	Description	Position
32694	Capacitor for 370TCV	1	14859	Power Cord for 370TCV	11	32706	Motor Hinge for 370TCV	18
32695	Capacitor Bracket for 370TCV	2	32701	Wing Nut for 370TCV	12	32707	Set Screw 5x8 TC for 370TCV	19
32696	Washer 5 for 370TCV	3	32702	Washer 6A Wide for 370TCV	13	32708	Screw TC 4x10 for 370TCV	20
32697	Screw 5x10 TC for 370TCV	4	32703	Motor Bracket for 370TCV	14	32709	Terminal Block for 370TCV	21
32698	Switch - On / Off for 370TCV	5 - 7	32704	Adjustment Rod for 370TCV	15	32710	Tapping Screw for 370TCV	22
32699	Motor for 370TCV	9 - 11, 16	32705	Motor Support Shaft for 370TCV	17	32711	Stop Plate for 370TCV	23

Sharpening Assembly

Item No.	Description	Position	Item No.	Description	Position	Item No.	Description	Position
32712	Sharpener Support Bracket for 370TCV	1	32722	Sharpener Push Button for 370TCV	11	32732	Screw TE 8x20 for 370TCV	21
32713	Screw TPSV 6x12 for 370TCV	2	32723	Spring for 370TCV	12	32733	Washer 8 for 370TCV	22
32714	Shaft for Sharpener for 370TCV	3	32724	Screw TC for 370TCV	13	32734	Sharpener Cover for 370TCV	23
32715	Set Screw 5x40 for 370TCV	4	32725	Washer 3 for 370TCV	14	32735	Sharpener Cover Knob for 370TCV	24
32716	Set Screw 5x30 for 370TCV	5	32726	Sharpener Pin for 370TCV	15	32736	Screw TC 6x12 for 370TCV	25
32717	Nut 6 for 370TCV	6	32727	Sharpener Pin for 370TCV	16	32737	Set Screw 6x8 TC for 370TCV	26
32718	Sharpener Screw for 370TCV	7	32728	Sharpener Body for 370TCV	17	32516	Finishing Stone for 370TCV	27
32719	Ball Bearing for 370TCV	8	32729	Screw TC 4x20 for 370TCV	18	32738	Grinding Stone for 370TCV	28
32720	Washer 6 for 370TCV	9	32730	Washer 4 for 370TCV	19	64809	Complete Sharpening Assembly for 370TCV	
32721	Nut 6 for 370TCV	10	32731	Sharpener Tie Rod for 370TCV	20			

Food Tray Assembly

Item No.	Description	Position	Item No.	Description	Position	Item No.	Description	Position
32739	Screw TE 8x35 for 370TCV	1	32749	Screw TE 8x20 for 370TCV	11	32759	Presser Plate for 370TCV	21
32740	Washer 8 for 370TCV	2	32750	Washer 8 for 370TCV	12	32760	Set Screw 6x8 TC for 370TCV	22
32741	Carriage Plate Support V for 370TCV	3	32751	Stud 5 MA for 370TCV	13	32761	End Block for 370TCV	23
32742	Carriage Plate Support H for 370TCV	4	32752	Carriage Plate - Small for 370TCV	14	32762	Inside Block for 370TCV	24
32743	Nut for 370TCV	5	32753	Washer 6x18 for 370TCV	15	32763	Set Screw 6x8 TC for 370TCV	25
32744	Washer 6x18 for 370TCV	6	32754	Nut 6 for 370TCV	16	32764	Rubber Washer for 370TCV	26
32745	Carriage Safety Guard for 370TCV	7	32755	Meat Grip Handle for 370TCV	17	32765	Spacer for 370TCV	27
32746	Stud 6x50 for 370TCV	8	32756	Aluminum Spacer for 370TCV	18	32766	Bracket for 370TCV	28
32747	Spacer for 370TCV	9	32757	Wavy Washer for 370TCV	19	32767	Stud PVC for 370TCV	29
32748	Carriage Plate - Large for 370TCV	10	32758	Stud 12 MA for 370TCV	20	32768	Presser Rod for 370TCV	30

Electrical Schematics

Model MS-IT-0300-V 13647

Model MS-IT-0330-V 13648

Model MS-IT-0350-V 13649

Model MS-IT-0370-V 13650

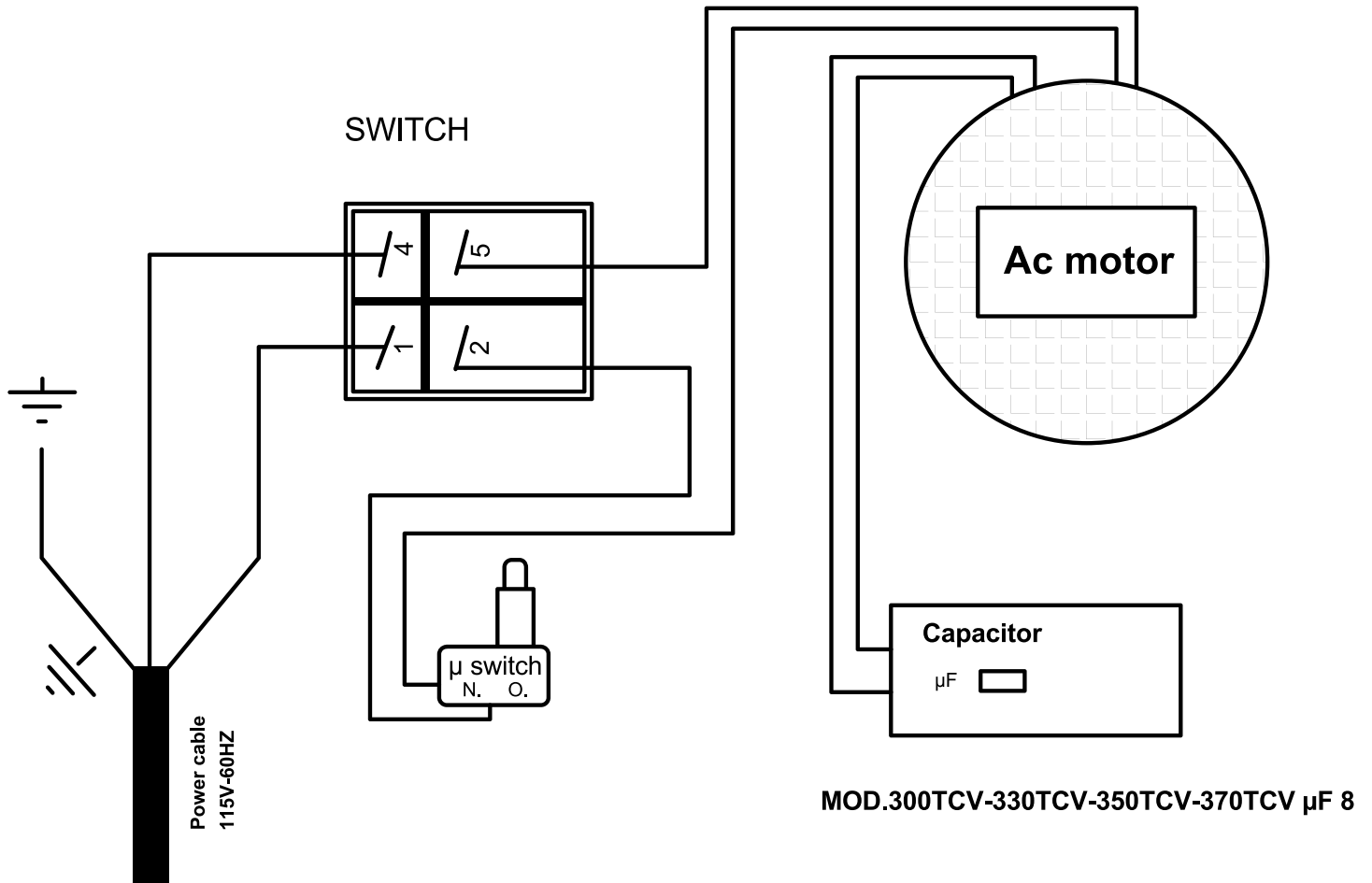



Warranty Registration

Thank you for purchasing an Omcan product. To register your warranty for this product, complete the information below, tear off the card at the perforation and then send to the address specified below. You can also register online by visiting:

Merci d'avoir acheté un produit Omcan. Pour enregistrer votre garantie pour ce produit, complétez les informations ci-dessous, détachez la carte au niveau de la perforation, puis l'envoyer à l'adresse spécifiée ci-dessous. Vous pouvez également vous inscrire en ligne en visitant:

Gracias por comprar un producto Omcan usted. Para registrar su garantía para este producto, complete la información a continuación, cortar la tarjeta en la perforación y luego enviarlo a la dirección indicada a continuación. También puede registrarse en línea en:

www.omcan.com/warrantyregistration.html

For mailing in Canada

Pour postale au Canada

Por correo en Canadá

OMCAN

PRODUCT WARRANTY REGISTRATION

3115 Pepper Mill Court,

Mississauga, Ontario

Canada, L5L 4X5

For mailing in the US

Pour diffusion aux États-Unis

Por correo en los EE.UU.

OMCAN

PRODUCT WARRANTY REGISTRATION

4450 Witmer Industrial Estates, Unit 4,

Niagara Falls, New York

USA, 14305

or Email to: service@omcan.com



Purchaser's Information

Name: _____

Company Name: _____

Address: _____

Telephone: _____

City: _____ Province or State: _____ Postal or Zip: _____

Email Address: _____

Country: _____

Type of Company:

Restaurant Bakery Deli

Butcher Supermarket Caterer

Institution (*specify*): _____

Other (*specify*): _____

Dealer from which Purchased: _____

Dealer City: _____ Dealer Province or State: _____

Invoice: _____

Model Name: _____ Model Number: _____

Serial Number: _____

Machine Description: _____

Date of Purchase (MM/DD/YYYY): _____

Date of Installation (MM/DD/YYYY): _____

Would you like to extend the warranty? Yes No

Thank you for choosing Omcan | Merci d'avoir choisi Omcan | Gracias por elegir Omcan



Since 1951 Omcan has grown to become a leading distributor of equipment and supplies to the North American food service industry. Our success over these many years can be attributed to our commitment to strengthen and develop new and existing relationships with our valued customers and manufacturers. Today with partners in North America, Europe, Asia and South America, we continually work to improve and grow the company. We strive to offer customers exceptional value through our qualified local sales and service representatives who provide convenient access to over 3,500 globally sourced products.

Depuis 1951 Omcan a grandi pour devenir un des “leaders” de la distribution des équipements et matériel pour l’industrie des services alimentaires en Amérique du Nord. Notre succès au cours de ces nombreuses années peut être attribué à notre engagement à renforcer et à développer de nouvelles et existantes relations avec nos clients et les fabricants de valeur. Aujourd’hui avec des partenaires en Amérique du Nord, Europe, Asie et Amérique du Sud, nous travaillons continuellement à améliorer et développer l’entreprise. Nous nous efforçons d’offrir à nos clients une valeur exceptionnelle grâce à nos ventes locales qualifiées et des représentants de service qui offrent un accès facile à plus de 3500 produits provenant du monde entier.

Desde 1951 Omcan ha crecido hasta convertirse en un líder en la distribución de equipos y suministros de alimentos en América del Norte industria de servicios. Nuestro éxito en estos años se puede atribuir a nuestro compromiso de fortalecer y desarrollar nuevas relaciones existentes con nuestros valiosos clientes y fabricantes. Hoy con socios de América del Norte, Europa, Asia y América del Sur, que trabajan continuamente para mejorar y crecer la empresa. Nos esforzamos por ofrecer a nuestros clientes valor excepcional a través de nuestro local de ventas y representantes de los servicios que proporcionan un fácil acceso a más de 3,500 productos con origen a nivel mundial.

