



Meat Mixers
Models MM-IT-0030, 0050
Items 37459, 13159
Instruction Manual



STOP
DO NOT RETURN
THIS PRODUCT TO THE STORE
For questions or assistance with this
product call OMCAN Toll Free:
1 800 465 0234
Customer Service
or
visit the Support section of
www.omcan.com

Revised - 02/28/2020



Toll Free: 1-800-465-0234
Fax: 905-607-0234
Email: service@omcan.com
www.omcan.com



Table of Contents

Model MM-IT-0030 / Model MM-IT-0050

Section	Page
General Information -----	3 - 4
Safety and Warranty -----	4 - 5
Technical Specifications -----	6
Operation -----	6 - 7
Maintenance -----	7 - 8
Parts Breakdown -----	9 - 12
Electrical Schematics -----	13
Notes -----	14
Warranty Registration -----	15



General Information

Omcan Manufacturing and Distributing Company Inc., Food Machinery of America, Inc. dba Omcan and Omcan Inc. are not responsible for any harm or injury caused due to any person's improper or negligent use of this equipment. The product shall only be operated by someone over the age of 18, of sound mind, and not under the influence of any drugs or alcohol, who has been trained in the correct operation of this machine, and is wearing authorized, proper safety clothing. Any modification to the machine voids any warranty, and may cause harm to individuals using the machine or in the vicinity of the machine while in operation.

CHECK PACKAGE UPON ARRIVAL

Upon receipt of an Omcan shipment please inspect for external damage. If no damage is evident on the external packaging, open carton to ensure all ordered items are within the box, and there is no concealed damage to the machine. If the package has suffered rough handling, bumps or damage (visible or concealed), please note it on the bill of lading before accepting the delivery and contact Omcan within 24 hours, so we may initiate a claim with the carrier. A detailed report on the extent of the damage caused to the machine must be filled out within three days, from the delivery date shown in the shipping documents. Omcan has no recourse for damaged products that were shipped collect or third party.

Before operating any equipment, always read and familiarize yourself with all operation and safety instructions.

Omcan would like to thank you for purchasing this machine. It's of the utmost importance to save these instructions for future reference. Also save the original box and packaging for shipping the equipment if servicing or returning of the machine is required.

Omcan Fabrication et distribution Compañie Limité et Food Machinery d'Amérique, dba Omcan et Omcan Inc. ne sont pas responsables de tout dommage ou blessure causé du fait que toute personne ait utilisé cet équipement de façon irrégulière. Le produit ne doit être exploité que par quelqu'un de plus de 18 ans, saine d'esprit, et pas sous l'influence d'une drogue ou d'alcool, qui a été formé pour utiliser cette machine correctement, et est vêtu de vêtements de sécurité approprié. Toute modification de la machine annule toute garantie, et peut causer un préjudice à des personnes utilisant la machine ou des personnes à proximité de la machine pendant son fonctionnement.

VÉRIFIEZ LE COLIS DÈS RÉCEPTION

Dès réception d'une expédition d'Omcan veuillez inspecter pour dommages externes. Si aucun dommage n'est visible sur l'emballage externe, ouvrez le carton afin de s'assurer que tous les éléments commandés sont dans la boîte, et il n'y a aucun dommage dissimulé à la machine. Si le colis n'a subi aucune mauvaises manipulations, de bosses ou de dommages (visible ou cachée), notez-le sur le bond de livraison avant d'accepter la livraison et contactez Omcan dans les 24 heures qui suivent, pour que nous puissions engager une réclamation auprès du transporteur. Un rapport détaillé sur l'étendue des dommages causés à la machine doit être rempli dans un délai de trois jours, à compter de la date de livraison indiquée dans les documents d'expédition. Omcan n'a aucun droit de recours pour les produits endommagés qui ont été expédiés ou cueilli par un tiers transporteur.

General Information

Avant d'utiliser n'importe quel équipement, toujours lire et vous familiariser avec toutes les opérations et les consignes de sécurité.

Omcan voudrais vous remercier d'avoir choisi cette machine. Il est primordial de conserver ces instructions pour une référence ultérieure. Également conservez la boîte originale et l'emballage pour l'expédition de l'équipement si l'entretien ou le retour de la machine est nécessaire.

Omcan Empresa De Fabricacion Y Distribucion Inc. Y Maquinaria De Alimentos De America, Inc. dba Omcan y Omcan Inc. no son responsables de ningun daño o perjuicio causado por cualquier persona inadecuada o el uso descuidado de este equipo. El producto solo podra ser operado por una persona mayor de 18 años, en su sano juicio y no bajo alguna influencia de droga o alcohol, y que este ha sido entrenado en el correcto funcionamiento de esta máquina, y ésta usando ropa apropiada y autorizada. Cualquier modificación a la máquina anula la garantía y puede causar daños a las personas usando la máquina mientras esta en el funcionamiento.

REVISE EL PAQUETE A SU LLEGADA

Tras la recepcion de un envio Omcan favor inspeccionar daños externos. Si no hay daños evidentes en el empaque exterior, Habra el carton para asegurarse que todos los articulos solicitados estén dentro de la caja y no encuentre daños ocultos en la máquina. Si el paquete ha sufrido un manejo de poco cuidado, golpes o daños (visible o oculto) por favor anote en la factura antes de aceptar la entrega y contacte Omcan dentro de las 24 horas, de modo que podamos iniciar una reclamación con la compañía. Un informe detallado sobre los daños causados a la máquina debe ser llenado en el plazo de tres días, desde la fecha de entrega que se muestra en los documentos de envío. Omcan no tiene ningun recurso por productos dañados que se enviaron a recoger por terceros.

Antes de utilizar cualquier equipo, siempre lea y familiarizarse con todas las instrucciones de funcionamiento y seguridad.

Omcan le gustaría darle las gracias por la compra de esta máquina. Es de la mayor importancia para salvar estas instrucciones para futuras consultas. Además, guarda la caja original y el embalaje para el envío del equipo si servicio técnico o devolución de la máquina que se requiere.

Safety and Warranty

Carefully read the following before using these machines:

1. Keep the place of work tidy and clean.
2. Keep children away from the mixing machine operating area.
3. Use the machine only for the purposes for which it has been designed. Utilization for other purposes than the kneading of meat lard/spices/mixtures may result in unsafe conditions.
4. Do not overload the machine.
5. The machine is equipped with a safety interlock which prevents the unit to operate if the cover of the tank

Safety and Warranty

containing the meat mixture is opened, or not fully closed.

6. Before operating, make sure that no foreign bodies are in the tank and that the tank has been thoroughly washed.
7. Any kind of operation, such as cleaning, control of the meat mixture, adjustment, assembling etc., should always be performed with the machine in the stop position and the plug removed from the outlet.
8. Make sure that the power supply matches the values shown on the rating plate.
9. Use only original spare parts and accessories.
10. Never submerge the machine in water or place it under a running tap. This will cause a hazard.
11. Do not pull the power cord to unplug.
12. The machine must be properly grounded.
13. Replacement of the power cord and electrical repairs should only be performed by authorized Omcan technicians.

1 YEAR PARTS AND LABOUR BENCH WARRANTY FOR MM-IT-0030

Within the warranty period, contact Omcan Inc. at 1-800-465-0234 to schedule a drop off to either an Omcan authorized service depot in the area, or to an Omcan Service warehouse to repair the equipment.

Unauthorized maintenance will void the warranty. Warranty covers electrical and part failures, not improper use.

1 YEAR PARTS AND LABOUR WARRANTY FOR MM-IT-0050

Within the warranty period, contact Omcan Inc. at 1-800-465-0234 to schedule an Omcan authorized service technician to repair the equipment locally.

Unauthorized maintenance will void the warranty. Warranty covers electrical and part failures, not improper use.

Please see <https://omcan.com/disclaimer> for complete info.

WARNING:

The packaging components are classified as normal solid urban waste and can therefore be disposed of without difficulty.

In any case, for suitable recycling, we suggest disposing of the products separately (differentiated waste) according to the current norms.

DO NOT DISCARD ANY PACKAGING MATERIALS IN THE ENVIRONMENT!

Technical Specifications

Model	MM-IT-0030	MM-IT-0050
Power	1 HP / 0.75 kW	1.5 HP / 1.12 kW
Working Capacity	66.1 lbs. / 30 kgs.	110.2 lbs. / 50 kgs.
Tank Volume	40 L / 42.3 QT	73 L / 77 QT
Electrical	110V / 60Hz / 1Ph	220V / 60Hz / 1Ph
Weight	88 lbs. / 39.9 kgs.	165 lbs. / 75 kgs.
Packaging Weight	108 lbs. / 48.9 kgs.	185 lbs. / 84 kgs.
Dimensions	14.2" x 28.4" x 22.4" 360 x 720 x 570mm	18.9" x 31.5" x 42.1" 480 x 800 x 1070mm
Item Number	37459	13159

Operation

IMPORTANT

Before starting, make sure that the power supply corresponds to that shown on the rating plate placed on the unit.

PRELIMINARY OPERATIONS

ATTENTION

The disassembling of the kneading paddle mounted inside the tank can be made only when the first scraper of the paddle (near the side of the tank where is the geared-motor unit) is positioned in vertical position and in the lower part. If the machine was stopped with the first scraper in different position and the operation of the paddle disassembling is to be performed, press the button INDIETRO to obtain little rotations (step by step) up to reaching the correct position.

- Put the machine on a flat and stable surface. If the machine isn't stable, adjust the feet.
- To disassemble the kneading paddle from the tank, the paddle must be sustained with an hand while the other hand turns clockwise the handwheel till the pivot gets out from the paddle.
- Unthread the paddle from the tank by bringing it in the back part.
- Wash carefully under a water jet, out of range of the machine, the kneading paddle.
- Wash the tank and its safety cover going after the following instructions.
- Follow the inverse sequence to assemble the washed parts.

SETTING UP THE MACHINE

- The machine is now ready to operate and the tank can be filled with the meat mixture to be kneaded.
- After checking that the safety cover is properly placed on the tank, the plug can be attached to the power socket.

Operation

- With a minimum clockwise rotation on the central red button STOP the button will be automatically put (by a spring) in its withdrawn position: by pushing the button AVANTI the paddle will start to rotate to obtain the kneading of the meat mixture.

ATTENTION

If during the kneading operation the safety cover of the tank is raised the paddle is immediately stopped. To restart the operation the cover must be closed again and the button AVANTI pushed again.

- During the working phase it is possible, to better distribute the meat mixture in the tank, to invert the paddle rotation only at steps. To make this operation it is necessary first to stop the machine by pushing down the STOP button, second to rotate a little the STOP button to put it in the withdrawn position and third to push the button INDIETRO. The button INDIETRO gives only steps of inverse rotation and the paddle will be stopped as the button will be released.
- At the end of the kneading operation proceed as follows to empty-out the tank:
 - Push down the button STOP.
 - Disconnect the plug from the socket.
 - To release the tank turn the hand wheel for coming out the check pin from its housing.
 - To facilitate the tank unloading it is possible to rotate it up to the horizontal position; the sense of rotation is such to maintain on high the safety cover when open.
 - Unload the tank by hand.
 - Return back the tank in vertical position and reinsert the check pin in its housing with procedure inverse to the one above described.

Maintenance

DISASSEMBLING AND CLEANING

IMPORTANT

For the washing operations of the removable parts use only water (possibly warm water) and neutral detergent for pottery. For the washing operation of the tank it is possible to introduce water (possibly warm water) and/or additional neutral detergent for pottery which will be easily eliminated by using the overturning system; if some detergent for pottery was added remember to carefully wash (at the end) with pure water. For the cleaning of the machine structure and of the safety cover use first a damp cloth and then a dry cloth. Do not utilize in any case acid or caustic products.

MAINTENANCE

The machine don't need any regular maintenance; we remember that, to maintain the machine in excellent conditions it is enough to perform a scrupulous cleaning at the end of each working cycle.

For unusual maintenances it is advisable to use original spare parts made by the manufacturing company to avoid any inconvenience due to different manufacturing features. When ordering specify the model and the

Maintenance

serial number of the machine (the serial number is shown both on the tag placed on the machine and on the cover of this handbook).

ATTENTION

The motor mounted on the MM-IT-0030 and MM-IT-0050 is equipped with a thermic micro disjunctor, to avoid overheating due to improper use of the machine. We remember that, to make a good mixture, the maximum kneading time is 10 minutes. If the machine is in operation for 30 continuous minutes, the safety switch will turn off the mixer.

The micro-disjunctor switching on doesn't stop the machine completely; it causes the machine working exclusively by impulse controls, to enable the end of the kneading work.

In case of stopping during the work, act as follows:

1. Keep pressing the "AVANTI" button until you reach the desired mixture.
2. Push the "STOP" red button.
3. Unload the tank.
4. Unplug from the socket.
5. Wait for the motor to cool.
6. Switch on again.

ACCIDENTAL STOPPING

If the machine stops accidentally during the processing operation, before investigating the reasons for this failure, it is necessary to stop at once the supply of electric current to the motor by pushing down the red button STOP. Then the electric flex should be disconnected from the socket.

After that:

- If the stop is caused by lack of electric current supply due to a failure in the electricity network, do not reconnect the machine to the socket until normal conditions have been restored in the network.
- In case the inconvenience is due to reasons connected with the power unit, contact the dealer to arrange for the machine to be checked, if necessary, by the manufacturer.
- If the stop is caused by the thermic micro-disjunctor switching on (due to a motor overheating), wait for the motor cooling and then switch on again the machine.

REFERENCE

Item Number	Model Number	Description	Manufacturer Model Number
37459	MM-IT-0030	Meat Mixer 66 lbs. / 30 kgs. 1 HP / 746 W 110V/60/1 cQPSus	MX30
13159	MM-IT-0050	Meat Mixer 110 lbs. / 50 kgs. 1.5 HP / 1119 W 220V/60/1 cQPS	MX50

Parts Breakdown

Model MM-IT-0030 37459

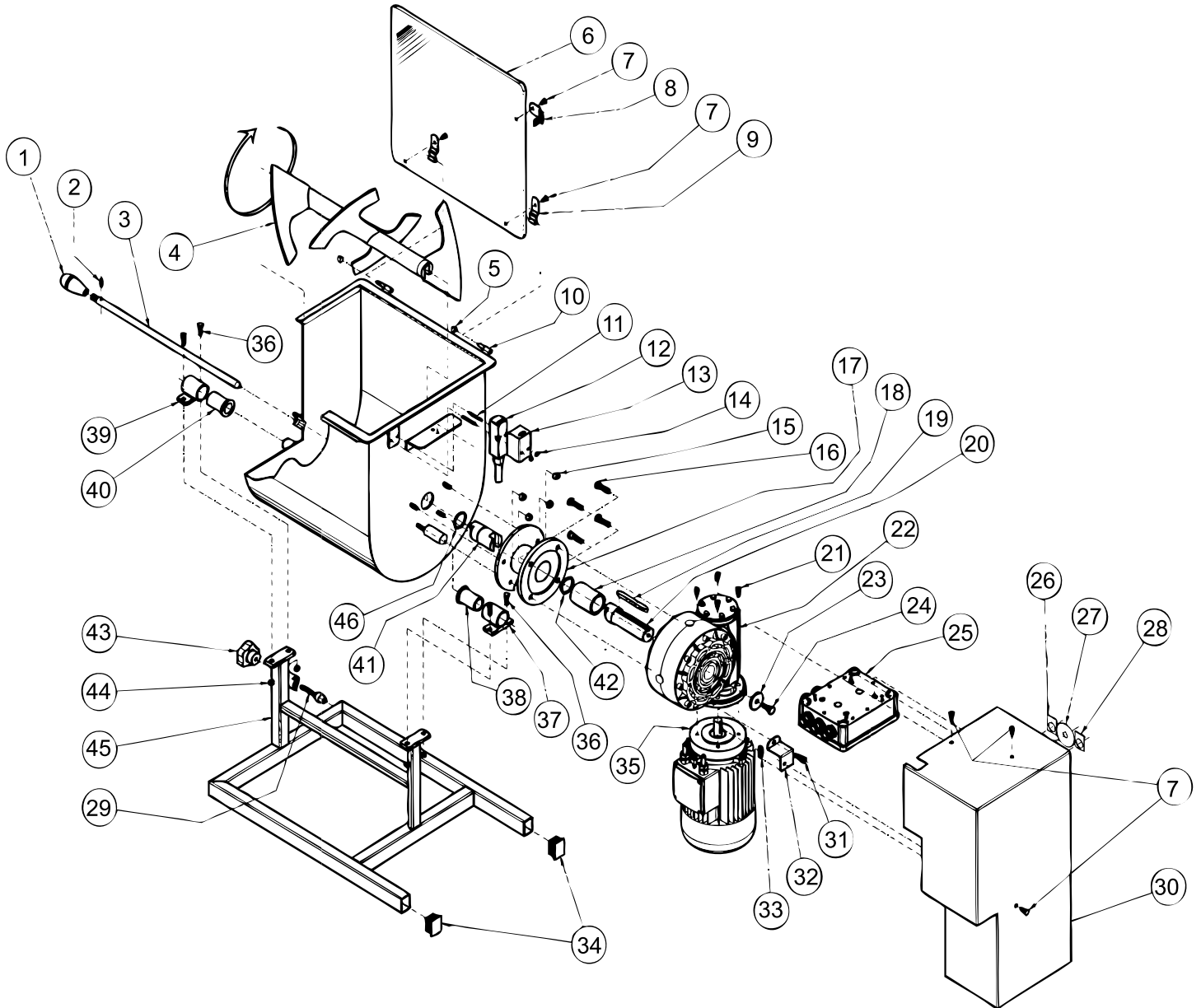

Parts Breakdown

Model MM-IT-0030 37459

Item No.	Description	Position	Item No.	Description	Position	Item No.	Description	Position
43269	Handle M10 for MX30	1	43271	Supporting Gear 30 Single-Blade for MX30	17	43853	Key Shaft 6x8 L.40 for MX30	33
43277	Elastic Pin 5x18 for MX30	2	43272	Bush Teflon Tree Rioutore Single Blade 30 kg. for MX30	18	43854	Plug Tube for MX30	34
43278	Auction Pala 30 kg. Single-Blade for MX30	3	43273	Key Tree 6x8 L.70 for MX30	19	43855	Engine 80HP1 Single Blade 30 kg. for MX30	35
43279	Pala 30 kg. Single-Blade for MX30	4	43274	Shaft Gear 30 kg. Single-Blade for MX30	20	43856	Screw Hex Head Stainless M8x25 for MX30	36
43280	Inox Nut M6 for MX30	5	43275	Hex Head Screw M8x25 Zinc for MX30	21	43857	Group Rotation Tank Mod. Short for MX30	37
43281	Cover Transparent 30 kg. Single-Blade for MX30	6	43276	Gear Single Blade 30 kg. for MX30	22	43858	Bush Teflon Group Rotation Mod. Short for MX30	38
43282	Hex Head Screw M6x10 Inox for MX30	7	43843	Flat Washer Galvanized 10x40 for MX30	23	43859	Group Rotation Tank Mod. Long for MX30	39
43283	Bracket Micro for MX30	8	43844	Hex Head Screw M08x20 Zincata for MX30	24	43860	Bush Teflon Group Rotation Mod. Long for MX30	40
43284	Hinge for MX30	9	43845	Panel Electric Model for MX30	25	43861	Fitting Shaft - Pala 30K for MX30	41
43285	Tank 30 kg. Single-Blade for MX30	10	42249	Plate Indicator Run - Next for MX30	26	43862	O Ring Round Section 039.92x3.53 for MX30	42
43286	Pin Pilettato M5x45 for MX30	11	43847	Marker Plate - Emergency Stop for MX30	27	43863	Flyer M10 for MX30	43
43287	Micro Blocking Safety for MX30	12	43848	Plate Indicator Run - Back for MX30	28	43864	Inox Nut M8 for MX30	44
43288	Carter Micro 30 Single-Blade for MX30	13	43849	Freeze Rotation Basin for MX30	29	43865	Frame Bench 30 kg. Single-Blade for MX30	45
43289	Inox Nut M5 for MX30	14	43850	Carter 30 kg. Single-Blade V1 for MX30	30	43866	O Ring Round Section 044.12x2.62 for MX30	46
43290	Locking Nut Stainless M8 for MX30	15	43851	Head Screw Cil. Esa. Inc. Zincata M8x20 for MX30	31			
43270	Screw Hex Head Galvanized M10x25 for MX30	16	43852	Bracket Locking Carter Single Blade for MX30	32			

Parts Breakdown

Model MM-IT-0050 13159

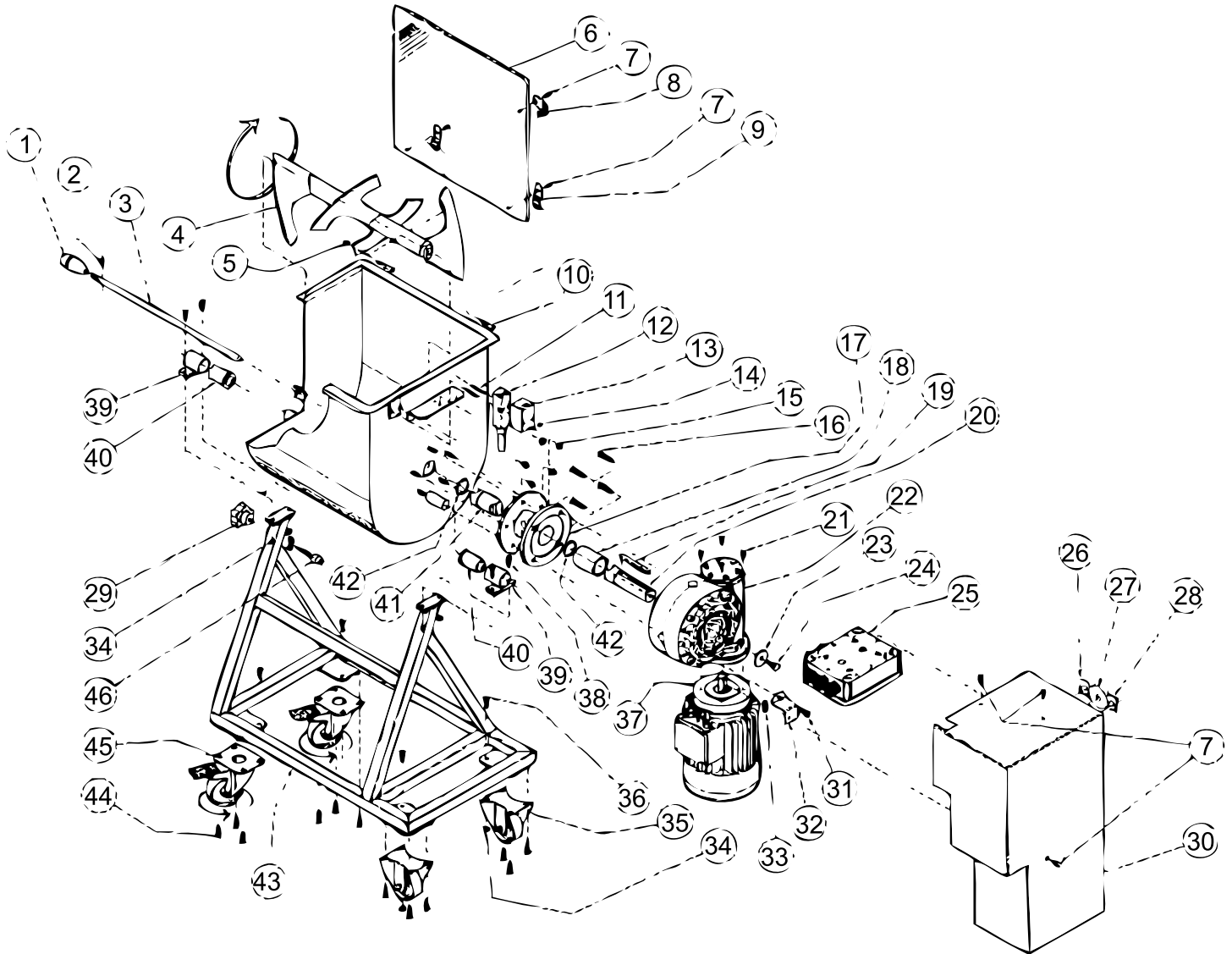

Parts Breakdown

Model MM-IT-0050 13159

Item No.	Description	Position	Item No.	Description	Position	Item No.	Description	Position
42385	Handle M10 for MX50	1	43808	Support Gear 50-75 Single Blade for MX50	17	42256	Key Shaft 6x8 L40 for MX50	33
42386	Elastic Pin 5x18 for MX50	2	43809	Bush Teflon Shaft Gear Single Blade 50-75 kg. for MX50	18	42257	Inox Nut M8 for MX50	34
42387	Auction Pala 50 kg. Single Blade for MX50	3	43810	Key Shaft 8x10 L.70 for MX50	19	42258	Fixed Wheel Cart for MX50	35
42388	Pala 50 kg. Single Blade for MX50	4	43811	Shaft Gear 50-75 kg. Single Blade for MX50	20	42259	Hex Head Screw M8x16 Inox for MX50	36
42389	Inox Nut M6 for MX50	5	43812	Hex Head Screw M8x25 Zinc for MX50	21	42260	Engine 50 HP 2 Single Blade 50-75 kg. for MX50	37
42390	Cover Transparant 50 kg. Single Blade for MX50	6	43813	Gear Single Blade for MX50	22	42261	Hex Head Screw M8x16 Inox for MX50	38
42391	Head Screw M6x10 Inox Hexagon for MX50	7	43814	Flat Washer Galvanized 10x40 for MX50	23	47262	Group Rotation Tank Mod. Long for MX50	39
42392	Bracket Micro for MX50	8	42270	Hex Head Screw M18x20 Zincata for MX50	24	42263	Bush Teflon Group Rotation Mod. Long for MX50	40
42393	Hinge for MX50	9	42271	Panel Electric Model for MX50	25	42264	Fitting Shaft - Pala for MX50	41
42394	Vasea 50 kg. Single Blade for MX50	10	42249	Plate Indicator Run - Next for MX50	26	42265	O Ring Round Section 040 for MX50	42
43802	Threaded Stud M5x45 for MX50	11	42250	Marker Plate - Emergency Stop for MX50	27	42266	Cart 50 kg. Single Blade for MX50	43
43803	Micro Blocking Safety for MX50	12	42251	Plate Indicator Run - Back for MX50	28	42267	Hex Head Screw M8x10 Inox for MX50	44
43804	Carter Micro 50-75 Single Blade 50-80-100 for MX50	13	42252	Flyer M10 for MX50	29	42268	Revolving Wheel with Brake Cart for MX50	45
43805	Inox Nut M5 for MX50	14	42253	Carter 50-75 kg. Single Blade V1 for MX50	30	42269	Freeze Rotation Basin for MX50	46
43806	Locking Nut Stainless M8 for MX50	15	42254	Screw Head CA Esainc Zincata M8x20 for MX50	31			
43807	Screw Hex Head Galvanized M10x25 for MX50	16	42255	Bracket Locking Carter Single Blade for MX50	32			

Electrical Schematics

Model MM-IT-0030 37459

Model MM-IT-0050 13159

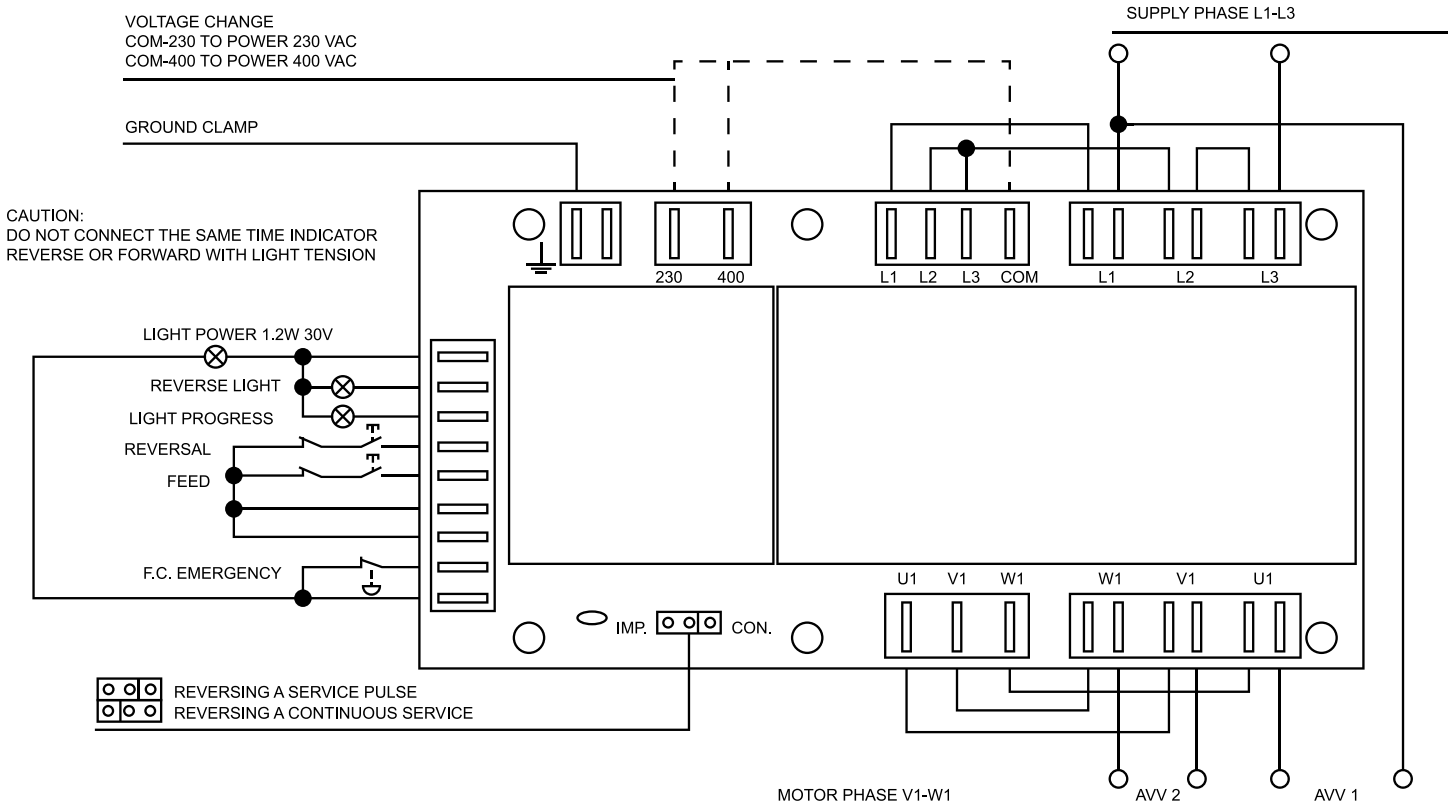



Warranty Registration

Thank you for purchasing an Omcan product. To register your warranty for this product, complete the information below, tear off the card at the perforation and then send to the address specified below. You can also register online by visiting:

Merci d'avoir acheté un produit Omcan. Pour enregistrer votre garantie pour ce produit, complétez les informations ci-dessous, détachez la carte au niveau de la perforation, puis l'envoyer à l'adresse spécifiée ci-dessous. Vous pouvez également vous inscrire en ligne en visitant:

Gracias por comprar un producto Omcan usted. Para registrar su garantía para este producto, complete la información a continuación, cortar la tarjeta en la perforación y luego enviarlo a la dirección indicada a continuación. También puede registrarse en línea en:

<https://omcan.com/warranty-registration/>

For mailing in Canada

Pour postale au Canada

Por correo en Canadá

OMCAN

PRODUCT WARRANTY REGISTRATION

3115 Pepper Mill Court,

Mississauga, Ontario

Canada, L5L 4X5

For mailing in the US

Pour diffusion aux États-Unis

Por correo en los EE.UU.

OMCAN

PRODUCT WARRANTY REGISTRATION

4450 Witmer Industrial Estates, Unit 4,

Niagara Falls, New York

USA, 14305

or email to: service@omcan.com



Purchaser's Information

Name: _____

Address: _____

City: _____ Province or State: _____ Postal or Zip: _____

Country: _____

Dealer from which Purchased: _____

Dealer City: _____ Dealer Province or State: _____

Invoice: _____

Model Name: _____ Model Number: _____

Machine Description: _____

Date of Purchase (MM/DD/YYYY): _____

Would you like to extend the warranty? Yes No

Company Name: _____

Telephone: _____

Email Address: _____

Type of Company:

Restaurant Bakery Deli

Butcher Supermarket Caterer

Institution (specify): _____

Other (specify): _____

Serial Number: _____

Date of Installation (MM/DD/YYYY): _____

Thank you for choosing Omcan | Merci d'avoir choisi Omcan | Gracias por elegir Omcan



Since 1951 Omcan has grown to become a leading distributor of equipment and supplies to the North American food service industry. Our success over these many years can be attributed to our commitment to strengthen and develop new and existing relationships with our valued customers and manufacturers. Today with partners in North America, Europe, Asia and South America, we continually work to improve and grow the company. We strive to offer customers exceptional value through our qualified local sales and service representatives who provide convenient access to over 5,000 globally sourced products.

Depuis 1951 Omcan a grandi pour devenir un des “leaders” de la distribution des équipements et matériel pour l’industrie des services alimentaires en Amérique du Nord. Notre succès au cours de ces nombreuses années peut être attribué à notre engagement à renforcer et à développer de nouvelles et existantes relations avec nos clients et les fabricants de valeur. Aujourd’hui avec des partenaires en Amérique du Nord, Europe, Asie et Amérique du Sud, nous travaillons continuellement à améliorer et développer l’entreprise. Nous nous efforçons d’offrir à nos clients une valeur exceptionnelle grâce à nos ventes locales qualifiées et des représentants de service qui offrent un accès facile à plus de 5000 produits provenant du monde entier.

Desde 1951 Omcan ha crecido hasta convertirse en un líder en la distribución de equipos y suministros de alimentos en América del Norte industria de servicios. Nuestro éxito en estos años se puede atribuir a nuestro compromiso de fortalecer y desarrollar nuevas relaciones existentes con nuestros valiosos clientes y fabricantes. Hoy con socios de América del Norte, Europa, Asia y América del Sur, que trabajan continuamente para mejorar y crecer la empresa. Nos esforzamos por ofrecer a nuestros clientes valor excepcional a través de nuestro local de ventas y representantes de los servicios que proporcionan un fácil acceso a más de 5,000 productos con origen a nivel mundial.

