



Meat Grinder
Model MG-IT-0022
Item 41421
Instruction Manual



Revised - 03/11/2020



Toll Free: 1-800-465-0234
Fax: 905-607-0234
Email: service@omcan.com
www.omcan.com

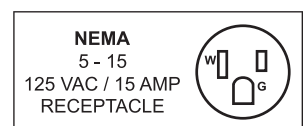

Table of Contents

Model MG-IT-0022

Section	Page
General Information -----	3 - 4
Safety and Warranty -----	4 - 5
Technical Specifications -----	6
Installation and Operation -----	6 - 8
Maintenance -----	8 - 9
Troubleshooting -----	9 - 10
Parts Breakdown -----	10 - 11
Electrical Schematics -----	12
Notes -----	13 - 14
Warranty Registration -----	15



General Information

Omcan Manufacturing and Distributing Company Inc., Food Machinery of America, Inc. dba Omcan and Omcan Inc. are not responsible for any harm or injury caused due to any person's improper or negligent use of this equipment. The product shall only be operated by someone over the age of 18, of sound mind, and not under the influence of any drugs or alcohol, who has been trained in the correct operation of this machine, and is wearing authorized, proper safety clothing. Any modification to the machine voids any warranty, and may cause harm to individuals using the machine or in the vicinity of the machine while in operation.

CHECK PACKAGE UPON ARRIVAL

Upon receipt of an Omcan shipment please inspect for external damage. If no damage is evident on the external packaging, open carton to ensure all ordered items are within the box, and there is no concealed damage to the machine. If the package has suffered rough handling, bumps or damage (visible or concealed), please note it on the bill of lading before accepting the delivery and contact Omcan within 24 hours, so we may initiate a claim with the carrier. A detailed report on the extent of the damage caused to the machine must be filled out within three days, from the delivery date shown in the shipping documents. Omcan has no recourse for damaged products that were shipped collect or third party.

Before operating any equipment, always read and familiarize yourself with all operation and safety instructions.

Omcan would like to thank you for purchasing this machine. It's of the utmost importance to save these instructions for future reference. Also save the original box and packaging for shipping the equipment if servicing or returning of the machine is required.

Omcan Fabrication et distribution Compañie Limité et Food Machinery d'Amérique, dba Omcan et Omcan Inc. ne sont pas responsables de tout dommage ou blessure causé du fait que toute personne ait utilisé cet équipement de façon irrégulière. Le produit ne doit être exploité que par quelqu'un de plus de 18 ans, saine d'esprit, et pas sous l'influence d'une drogue ou d'alcool, qui a été formé pour utiliser cette machine correctement, et est vêtu de vêtements de sécurité approprié. Toute modification de la machine annule toute garantie, et peut causer un préjudice à des personnes utilisant la machine ou des personnes à proximité de la machine pendant son fonctionnement.

VÉRIFIEZ LE COLIS DÈS RÉCEPTION

Dès réception d'une expédition d'Omcan veuillez inspecter pour dommages externes. Si aucun dommage n'est visible sur l'emballage externe, ouvrez le carton afin de s'assurer que tous les éléments commandés sont dans la boîte, et il n'y a aucun dommage dissimulé à la machine. Si le colis n'a subi aucune mauvaises manipulations, de bosses ou de dommages (visible ou cachée), notez-le sur le bond de livraison avant d'accepter la livraison et contactez Omcan dans les 24 heures qui suivent, pour que nous puissions engager une réclamation auprès du transporteur. Un rapport détaillé sur l'étendue des dommages causés à la machine doit être rempli dans un délai de trois jours, à compter de la date de livraison indiquée dans les documents d'expédition. Omcan n'a aucun droit de recours pour les produits endommagés qui ont été expédiés ou cueilli par un tiers transporteur.

General Information

Avant d'utiliser n'importe quel équipement, toujours lire et vous familiariser avec toutes les opérations et les consignes de sécurité.

Omcan voudrais vous remercier d'avoir choisi cette machine. Il est primordial de conserver ces instructions pour une référence ultérieure. Également conservez la boîte originale et l'emballage pour l'expédition de l'équipement si l'entretien ou le retour de la machine est nécessaire.

Omcan Empresa De Fabricacion Y Distribucion Inc. Y Maquinaria De Alimentos De America, Inc. dba Omcan y Omcan Inc. no son responsables de ningun daño o perjuicio causado por cualquier persona inadecuada o el uso descuidado de este equipo. El producto solo podra ser operado por una persona mayor de 18 años, en su sano juicio y no bajo alguna influencia de droga o alcohol, y que este ha sido entrenado en el correcto funcionamiento de esta máquina, y ésta usando ropa apropiada y autorizada. Cualquier modificación a la máquina anula la garantía y puede causar daños a las personas usando la máquina mientras esta en el funcionamiento.

REVISE EL PAQUETE A SU LLEGADA

Tras la recepcion de un envio Omcan favor inspeccionar daños externos. Si no hay daños evidentes en el empaque exterior, Habra el carton para asegurarse que todos los articulos solicitados estén dentro de la caja y no encuentre daños ocultos en la máquina. Si el paquete ha sufrido un manejo de poco cuidado, golpes o daños (visible o oculto) por favor anote en la factura antes de aceptar la entrega y contacte Omcan dentro de las 24 horas, de modo que podamos iniciar una reclamación con la compañía. Un informe detallado sobre los daños causados a la máquina debe ser llenado en el plazo de tres días, desde la fecha de entrega que se muestra en los documentos de envío. Omcan no tiene ningun recurso por productos dañados que se enviaron a recoger por terceros.

Antes de utilizar cualquier equipo, siempre lea y familiarizarse con todas las instrucciones de funcionamiento y seguridad.

Omcan le gustaría darle las gracias por la compra de esta máquina. Es de la mayor importancia para salvar estas instrucciones para futuras consultas. Además, guarda la caja original y el embalaje para el envío del equipo si servicio técnico o devolución de la máquina que se requiere.

Safety and Warranty

WARNINGS ON THE RESIDUAL RISKS

RESIDUAL RISK DUE TO THE FIXED PROTECTIONS REMOVAL OR INTERRUPTION ON BROKEN/ WORN PARTS.

The operator must not try to open or remove a fixed protection or tamper with a safety device.



Safety and Warranty

During operation, maintenance and cleaning, keep hands or other body parts away from the machines dangerous areas, a residual risk remains due to:

1. Knocks with the machines manufacturing parts.
2. Grazing and/or abrasion with the machines rough parts.
3. Cuts with the sharp parts.

PROTECTION DEVICES ON THE MACHINE

The machine protections and safety devices must not be removed.

The machines transmission parts are completely isolated by means of fixed protections which does not allow access. The moving elements are not isolated from fixed protections, moving protections or other safety devices. The grinding group parts are placed away from access points so they are not reachable.

DISCLAIMER

PLEASE RUN THE UNIT WITH A LIGHT, DISPOSABLE LOAD TO REMOVE ANY METAL SHAVINGS FROM THE MACHINE BEFORE FIRST USE!

1 YEAR PARTS AND LABOUR BENCH WARRANTY

Within the warranty period, contact Omcan Inc. at 1-800-465-0234 to schedule a drop off to either an Omcan authorized service depot in the area, or to an Omcan Service warehouse to repair the equipment.

Unauthorized maintenance will void the warranty. Warranty covers electrical and part failures not improper use.

Please see <https://omcan.com/disclaimer> for complete info.

WARNING:

The packaging components are classified as normal solid urban waste and can therefore be disposed of without difficulty.

In any case, for suitable recycling, we suggest disposing of the products separately (differentiated waste) according to the current norms.

DO NOT DISCARD ANY PACKAGING MATERIALS IN THE ENVIRONMENT!

Technical Specifications

Model	MG-IT-0022
Horsepower	1.25 HP
Power	920 W
RPM	100
Throat Opening	2" / 51mm approx
Electrical	110V / 60Hz / 1
Weight	40 lbs. / 18 kgs.
Packaging Weight	42 lbs. / 19 kgs.
Dimensions	19.9" x 9.5" x 15.8" / 505 x 240 x 400mm
Packaging Dimensions	26" x 20" x 20" / 660 x 508 x 508mm
Item Number	41421

Installation and Operation

TRANSPORTATION, HANDLING AND STORAGE

All transportation and handling operations must be performed from trained personnel and must have read and understood the safety precautions mentioned in this manual.

1. Perform the machine handling and transportation only when unplugged.
2. Verify that the lifting means are able to support the loading weight and overall dimensions in safe conditions.
3. Avoid dropping or shaking the unit during transportation.

PREPARATION PRELIMINARY OPERATIONS

STABILITY

The machines stability is designed so that it can be used without the risk of falling or unwanted movement. Ensure the machine is situated on a stable and level surface.

ELECTRICAL SUPPLY

The electrical supply connection must be in conformance with the country legislation in which it is being used.

1. The electrical supply must match the required specifications indicated on the rating plate. If excessive voltages are applied, some components will be damaged beyond repair.
2. The device must be grounded in conformance to the local standards.
3. The electrical supply cable outside the machine cover must be adequately protected, to ensure it is not damaged.

Installation and Operation

GRINDING GROUP ASSEMBLY / DISASSEMBLY

The assembly / disassembly operations of any machine part are performed with the machine in the OFF position, and the plug disconnected from the socket.

To assemble the grinder, do the following steps in this order:

1. Insert into the shaft (1) in order: the worm (2), the cutting knife oriented as shown in the figure (3), and the plate (4).
2. Screw down and tighten the screw (5).

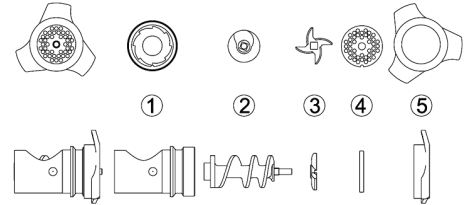

To disassemble, do the above procedure in the reverse order.

OPERATION INSTRUCTIONS

STARTING THE MACHINE

To start the machine, the switch has to be placed on the “I” position.

STOPPING THE MACHINE

To stop the machine, the switch has to be placed on the “O” position.

FUNCTIONING SAFETY

If the machine is under stress, operated for a long period of time or overloaded, it will stop immediately when the thermal protection turns on. In this case wait for the unit to cool completely before using again.

OPERATION

The machine operator can begin operation of the machine when:

1. The machine is installed properly.
2. The machine is connected to the electrical supply.
3. The hopper is inserted in the correct position.
4. The grinding group assembly is installed correctly.
5. The worm rotates in the correct direction.
6. Tests the switch.
7. Check that all safety conditions are being met.
8. Check that the plug is in the correct socket.
9. Place a collecting tray below the shaft to collect the final product.
10. Start the machine by placing the switch to the “I” position.
11. Manually introduce the chopped meat into the machine neck and use the supplied stomper to push the meat into the shaft.
12. Once the operation is completed, or when the product no longer comes out of the plate, place the switch to the “O” position to stop the machine.

It is recommended to only operate the machine when there is product in the unit.

Installation and Operation

AFTER EACH USE

Once the machine has been operated and is no longer in use, please do the following:

1. Before turning off the unit, wait until the food product has finished going through the plate.
2. Turn off the machine by placing the switch to the “O” position.
3. Unplug the unit from the electrical socket.
4. Perform the cleaning and maintenance steps detailed in the “Maintenance” section.

UNBLOCK IN CASE OF OBSTRUCTION

During operation, or during the worm rotation, due to the food products being introduced with incompatible parts (ie: bones), the machine could become blocked and cause a malfunction.

To be able to resume normal operation, the grinding group must be disassembled, and the blockage must be removed.

Maintenance

PROTECTIVE SAFETY DEVICES

For any procedures described in this section, it is necessary to remove some of the fixed protections from their positions. The removal can only be performed by an authorized Omcan technician. At the end of the maintenance procedures, these protections must be replaced and fastened in their original positions.

The machine must be switched off and unplugged prior to any maintenance and cleaning.

EXTRAORDINARY MAINTENANCE

In the event of any extraordinary maintenance, it can only be completed by an authorized Omcan service technician.

CLEANING

All cleaning procedures must be started only when the machine is no longer in operation and is unplugged from the electrical socket.

The machine, the electrical equipment and electrical components must never be submerged, sprayed, or washed with water. Use a dry cloth to wipe these components.

Maintenance

Follow the steps as listed:

FREQUENCY	PERSONNEL	SOLUTION
At the end of every use and before daily use.	Operator	DISINFECTION <ul style="list-style-type: none"> • Use PH neutral detergents. • Use demineralized water if temperatures exceed 60°C/140°F. • If any other products are used, they must be adequate to the materials being disinfected.
		PERIODS OF LONG INACTIVITY <ul style="list-style-type: none"> • If the machine has been inactive for a long period of time, vigorously wipe the machine with a cloth soaked in Vaseline to create a protective barrier.
		PRODUCTS NOT TO USE: <ul style="list-style-type: none"> • Compressed or pressurized air jets. • Vapor equipment. • Detergent that contains any of the following compounds: <ul style="list-style-type: none"> - Bleach. - Hydrochloric acid. - Products that are used to clear drains. - Caustic soda products for cleaning marble. - Etc. • Steel wool, brushes or abrasive discs produced with other metals or alloys, or tools that have previously cleaned other metals or alloys. • Detergents in abrasive dust. • Fuel, solvents or inflammable and/or corrosive fluids. • Substances used to clean silver.

Troubleshooting

The following indicated problems that may occur:

TYPE	POTENTIAL CAUSE/S	SOLUTIONS
The electrical supply is not adequate.	General blackout.	Contact an electrician.
	Blown fuse.	Replace the fuse, if the problem continues, contact an electrician.
The machine stops.	The protection device stops the machine.	Contact an electrician to eliminate the causes, once the cause has been determined, restore the machine to the recommended function.
	The cause could not be identified.	Contact Omcan directly.

Troubleshooting

The machine doesn't function: the worm will not rotate.	The electrical supply is not adequate.	Check and restore the electrical supply.
	The switch is on the "O" position.	Place the switch to the "I" position.
	Blown fuse.	Replace the fuse.
	The unit is overheated.	Wait for the unit to cool completely before starting.

REFERENCE

Item Number	Model Number	Description	Manufacturer Model Number
41421	MG-IT-0022	Meat Grinder #22 Cast Iron 100 RPM 1.25 HP / 920 W 110V/60/1 cCSAus	19600/CSA

Parts Breakdown

Model MG-IT-0022 41421

Item No.	Description	Position	Item No.	Description	Position	Item No.	Description	Position
15241	Plunger for 19600/CSA	1	27660	Sealing Ring for 19600/CSA	10	67479	Spacers Kit and Screws Kit and Gasket for 19600/CSA	33+34+44
20266	Hopper for 19600/CSA	2	15255	Housing for 19600/CSA	11	15247	Motor Cover for 19600/CSA	40
15250	Plastic Hopper for 19600/CSA	2	27663	Motor Reducer Gasket for 19600/CSA	12	31249	Switch for 19600/CSA	41
27649	Body without Bearing for 19600/CSA	3	19151	Large Gear for 19600/CSA	13	45128	Switch Box for 19600/CSA	42
15264	Plastic Bushing for 19600/CSA	4	66043	Small Gear for 19600/CSA	14	67477	Capacitor for 19600/CSA	43
24546	Worm with Pin for 19600/CSA	5+6	AC998	Stainless Steel Motor Covering for 19600/CSA	19	40300	Cooling Fan for 19600/CSA	
15230	Worm Pin for 19600/CSA	6	AC996	Base for 19600/CSA	20	67480	Motoreduction Unit for 19600/CSA	
67476	Screw Ring for 19600/CSA	9	15246	Knob for 19600/CSA	23			

Parts Breakdown

Model MG-IT-0022 41421

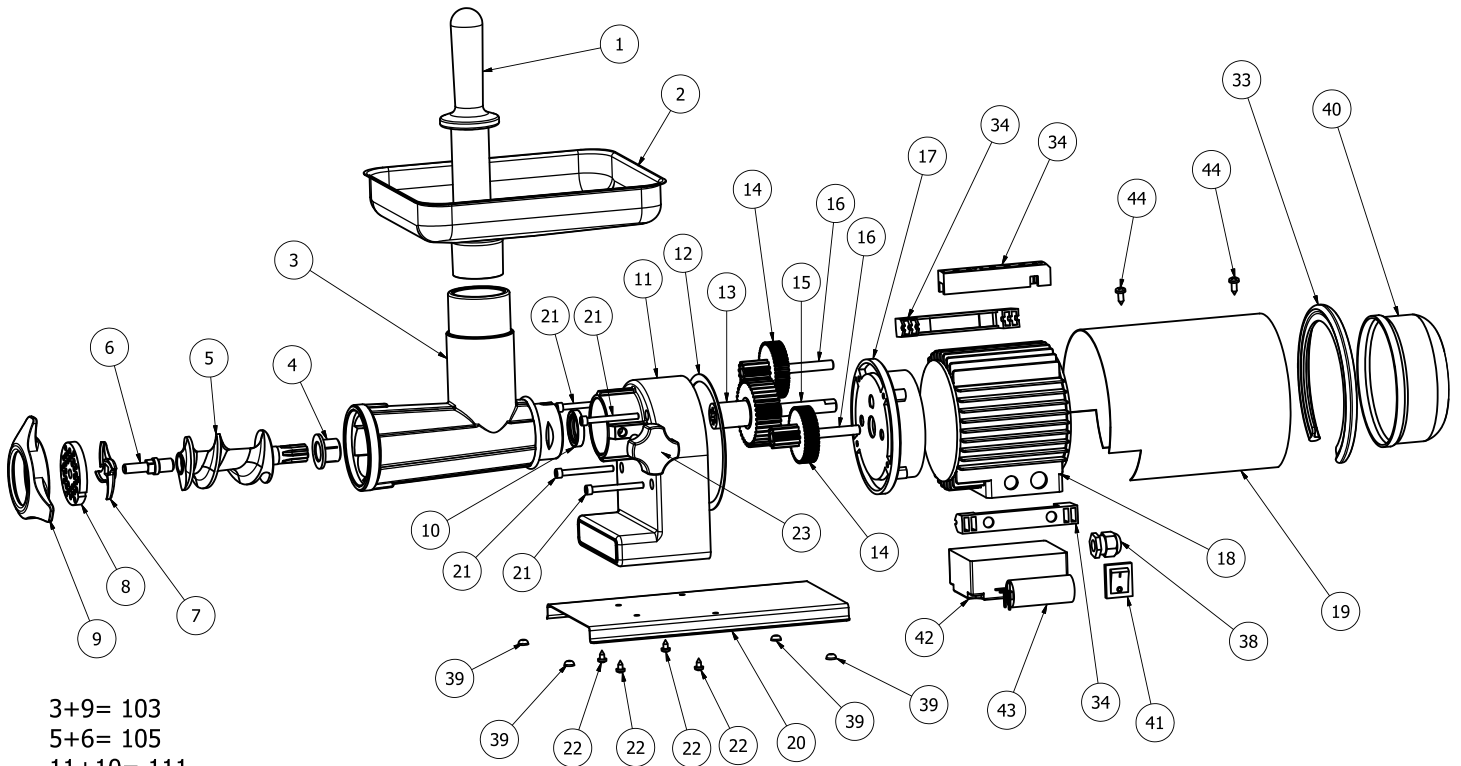

- 3+9= 103
- 5+6= 105
- 11+10= 111
- 33+34+44= 133
- (39x4)= 139
- 20+(39x4)= 120

Electrical Schematics

Model MG-IT-0022 41421

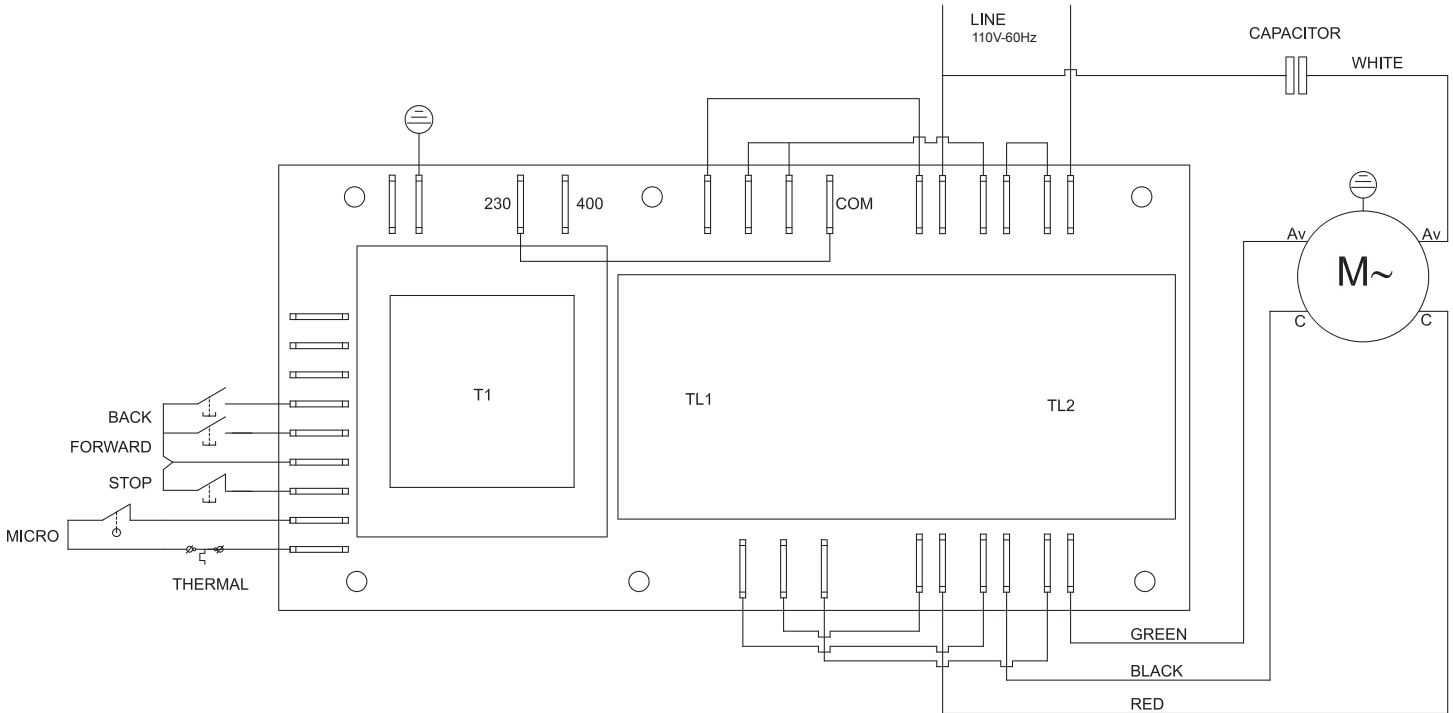



Warranty Registration

Thank you for purchasing an Omcan product. To register your warranty for this product, complete the information below, tear off the card at the perforation and then send to the address specified below. You can also register online by visiting:

Merci d'avoir acheté un produit Omcan. Pour enregistrer votre garantie pour ce produit, complétez les informations ci-dessous, détachez la carte au niveau de la perforation, puis l'envoyer à l'adresse spécifiée ci-dessous. Vous pouvez également vous inscrire en ligne en visitant:

Gracias por comprar un producto Omcan usted. Para registrar su garantía para este producto, complete la información a continuación, cortar la tarjeta en la perforación y luego enviarlo a la dirección indicada a continuación. También puede registrarse en línea en:

<https://omcan.com/warranty-registration/>

For mailing in Canada

Pour postale au Canada

Por correo en Canadá

OMCAN

PRODUCT WARRANTY REGISTRATION

3115 Pepper Mill Court,

Mississauga, Ontario

Canada, L5L 4X5

For mailing in the US

Pour diffusion aux États-Unis

Por correo en los EE.UU.

OMCAN

PRODUCT WARRANTY REGISTRATION

4450 Witmer Industrial Estates, Unit 4,

Niagara Falls, New York

USA, 14305

or email to: service@omcan.com



Purchaser's Information

Name: _____

Address: _____

City: _____ Province or State: _____ Postal or Zip: _____

Country: _____

Dealer from which Purchased: _____

Dealer City: _____ Dealer Province or State: _____

Invoice: _____

Model Name: _____ Model Number: _____

Machine Description: _____

Date of Purchase (MM/DD/YYYY): _____

Would you like to extend the warranty? Yes No

Company Name: _____

Telephone: _____

Email Address: _____

Type of Company:

Restaurant Bakery Deli

Butcher Supermarket Caterer

Institution (*specify*): _____

Other (*specify*): _____

Serial Number: _____

Date of Installation (MM/DD/YYYY): _____

Thank you for choosing Omcan | Merci d'avoir choisi Omcan | Gracias por elegir Omcan



Since 1951 Omcan has grown to become a leading distributor of equipment and supplies to the North American food service industry. Our success over these many years can be attributed to our commitment to strengthen and develop new and existing relationships with our valued customers and manufacturers. Today with partners in North America, Europe, Asia and South America, we continually work to improve and grow the company. We strive to offer customers exceptional value through our qualified local sales and service representatives who provide convenient access to over 5,000 globally sourced products.

Depuis 1951 Omcan a grandi pour devenir un des “leaders” de la distribution des équipements et matériel pour l’industrie des services alimentaires en Amérique du Nord. Notre succès au cours de ces nombreuses années peut être attribué à notre engagement à renforcer et à développer de nouvelles et existantes relations avec nos clients et les fabricants de valeur. Aujourd’hui avec des partenaires en Amérique du Nord, Europe, Asie et Amérique du Sud, nous travaillons continuellement à améliorer et développer l’entreprise. Nous nous efforçons d’offrir à nos clients une valeur exceptionnelle grâce à nos ventes locales qualifiées et des représentants de service qui offrent un accès facile à plus de 5000 produits provenant du monde entier.

Desde 1951 Omcan ha crecido hasta convertirse en un líder en la distribución de equipos y suministros de alimentos en América del Norte industria de servicios. Nuestro éxito en estos años se puede atribuir a nuestro compromiso de fortalecer y desarrollar nuevas relaciones existentes con nuestros valiosos clientes y fabricantes. Hoy con socios de América del Norte, Europa, Asia y América del Sur, que trabajan continuamente para mejorar y crecer la empresa. Nos esforzamos por ofrecer a nuestros clientes valor excepcional a través de nuestro local de ventas y representantes de los servicios que proporcionan un fácil acceso a más de 5,000 productos con origen a nivel mundial.

