



Bread Graters
Models GR-IT-0080, 0080-S
Items 11411, 23865
Instruction Manual



STOP
DO NOT RETURN
THIS PRODUCT TO THE STORE
For questions or assistance with this product call OMCAN Toll Free: 1 800 465 0234 Customer Service or visit the Support section of www.omcan.com

Revised - 07/14/2016



Toll Free: 1-800-465-0234
Fax: 905-607-0234
Email: service@omcan.com
www.omcan.com

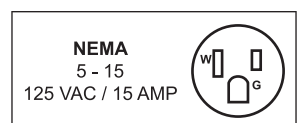

Table of Contents

Model GR-IT-0080 / Model GR-IT-0080-S

Section	Page
General Information -----	3 - 4
Safety and Warranty -----	4 - 5
Technical Specifications -----	6
Installation -----	6 - 7
Operation -----	7 - 8
Maintenance -----	8 - 10
Parts Breakdown -----	11 - 16
Electrical Schematics -----	17
Notes -----	18
Warranty Registration -----	19



General Information

Omcan Manufacturing and Distributing Company Inc., Food Machinery of America, Inc. dba Omcan and Omcan Inc. are not responsible for any harm or injury caused due to any person's improper or negligent use of this equipment. The product shall only be operated by someone over the age of 18, of sound mind, and not under the influence of any drugs or alcohol, who has been trained in the correct operation of this machine, and is wearing authorized, proper safety clothing. Any modification to the machine voids any warranty, and may cause harm to individuals using the machine or in the vicinity of the machine while in operation.

CHECK PACKAGE UPON ARRIVAL

Upon receipt of an Omcan shipment please inspect for external damage. If no damage is evident on the external packaging, open carton to ensure all ordered items are within the box, and there is no concealed damage to the machine. If the package has suffered rough handling, bumps or damage (visible or concealed), please note it on the bill of lading before accepting the delivery and contact Omcan within 24 hours, so we may initiate a claim with the carrier. A detailed report on the extent of the damage caused to the machine must be filled out within three days, from the delivery date shown in the shipping documents. Omcan has no recourse for damaged products that were shipped collect or third party.

Before operating any equipment, always read and familiarize yourself with all operation and safety instructions.

Omcan would like to thank you for purchasing this machine. It's of the utmost importance to save these instructions for future reference. Also save the original box and packaging for shipping the equipment if servicing or returning of the machine is required.

Omcan Fabrication et distribution Compañie Limité et Food Machinery d'Amérique, dba Omcan et Omcan Inc. ne sont pas responsables de tout dommage ou blessure causé du fait que toute personne ait utilisé cet équipement de façon irrégulière. Le produit ne doit être exploité que par quelqu'un de plus de 18 ans, saine d'esprit, et pas sous l'influence d'une drogue ou d'alcool, qui a été formé pour utiliser cette machine correctement, et est vêtu de vêtements de sécurité approprié. Toute modification de la machine annule toute garantie, et peut causer un préjudice à des personnes utilisant la machine ou des personnes à proximité de la machine pendant son fonctionnement.

VÉRIFIEZ LE COLIS DÈS RÉCEPTION

Dès réception d'une expédition d'Omcan veuillez inspecter pour dommages externes. Si aucun dommage n'est visible sur l'emballage externe, ouvrez le carton afin de s'assurer que tous les éléments commandés sont dans la boîte, et il n'y a aucun dommage dissimulé à la machine. Si le colis n'a subi aucune mauvaises manipulations, de bosses ou de dommages (visible ou cachée), notez-le sur le bond de livraison avant d'accepter la livraison et contactez Omcan dans les 24 heures qui suivent, pour que nous puissions engager une réclamation auprès du transporteur. Un rapport détaillé sur l'étendue des dommages causés à la machine doit être rempli dans un délai de trois jours, à compter de la date de livraison indiquée dans les documents d'expédition. Omcan n'a aucun droit de recours pour les produits endommagés qui ont été expédiés ou cueilli par un tiers transporteur.

General Information

Avant d'utiliser n'importe quel équipement, toujours lire et vous familiariser avec toutes les opérations et les consignes de sécurité.

Omcan voudrais vous remercier d'avoir choisi cette machine. Il est primordial de conserver ces instructions pour une référence ultérieure. Également conservez la boîte originale et l'emballage pour l'expédition de l'équipement si l'entretien ou le retour de la machine est nécessaire.

Omcan Empresa De Fabricacion Y Distribucion Inc. Y Maquinaria De Alimentos De America, Inc. dba Omcan y Omcan Inc. no son responsables de ningun daño o perjuicio causado por cualquier persona inadecuada o el uso descuidado de este equipo. El producto solo podra ser operado por una persona mayor de 18 años, en su sano juicio y no bajo alguna influencia de droga o alcohol, y que este ha sido entrenado en el correcto funcionamiento de esta máquina, y ésta usando ropa apropiada y autorizada. Cualquier modificación a la máquina anula la garantía y puede causar daños a las personas usando la máquina mientras esta en el funcionamiento.

REVISE EL PAQUETE A SU LLEGADA

Tras la recepcion de un envio Omcan favor inspeccionar daños externos. Si no hay daños evidentes en el empaque exterior, Habra el carton para asegurarse que todos los articulos solicitados estén dentro de la caja y no encuentre daños ocultos en la máquina. Si el paquete ha sufrido un manejo de poco cuidado, golpes o daños (visible o oculto) por favor anote en la factura antes de aceptar la entrega y contacte Omcan dentro de las 24 horas, de modo que podamos iniciar una reclamación con la compañía. Un informe detallado sobre los daños causados a la máquina debe ser llenado en el plazo de tres días, desde la fecha de entrega que se muestra en los documentos de envío. Omcan no tiene ningun recurso por productos dañados que se enviaron a recoger por terceros.

Antes de utilizar cualquier equipo, siempre lea y familiarizarse con todas las instrucciones de funcionamiento y seguridad.

Omcan le gustaría darle las gracias por la compra de esta máquina. Es de la mayor importancia para salvar estas instrucciones para futuras consultas. Además, guarda la caja original y el embalaje para el envío del equipo si servicio técnico o devolución de la máquina que se requiere.

Safety and Warranty

- The equipped protections do not allow the operator to accidentally get in contact with the operating parts that move.
- The machine is equipped with an overload switch that protects the motor in the event of any undue stress as a prolonged blockage of the motor.
- Do not wear loose clothing when operating the machine.
- Make sure hair is gathered and secure to avoid injury.
- NEVER use tools not intended for the machine to help during operation.

Safety and Warranty

- NEVER touch the moving parts of the machine.
- NEVER connect the power source with wet hands or wet clothes.
- ALWAYS ground the machine properly.
- NEVER spray water or other liquid substances directly at the motor, power switch or any other electrical components.
- ALWAYS install equipment in working area with adequate light and away from CHILDREN and non-trained personnel.
- NEVER operate without all warning labels attached and owner/operator manual available.
- NEVER leave the machine unattended while operating.
- STOP the machine immediately if you hear abnormal noises or fear that injuries may occur.
- CONTACT your distributor if you have any problems with the installation or operation of this machine.
- ALWAYS turn the machine off before cleaning and maintenance.
- PROVIDE enough space around the machine.
- ALWAYS keep the floor dry. Wet floors may cause the operator to slip.
- ALWAYS turn the machine off in the case of a short circuit.
- NEVER let dust or water get into electrical or mechanical components of the machine.

1 YEAR PARTS AND LABOUR BENCH WARRANTY

Within the warranty period, contact Omcan Inc. At 1-800-465-0234 to schedule a drop off to either an Omcan authorized service depot in the area, or to an Omcan Service warehouse to repair the equipment.

Unauthorized maintenance will void the warranty. Warranty covers electrical and part failures, not improper use.

Please see www.omcan.com/warranty.html for complete info.

WARNING:

The packaging components are classified as normal solid urban waste and can therefore be disposed of without difficulty.

In any case, for suitable recycling, we suggest disposing of the products separately (differentiated waste) according to the current norms.

DO NOT DISCARD ANY PACKAGING MATERIALS IN THE ENVIRONMENT!

Technical Specifications

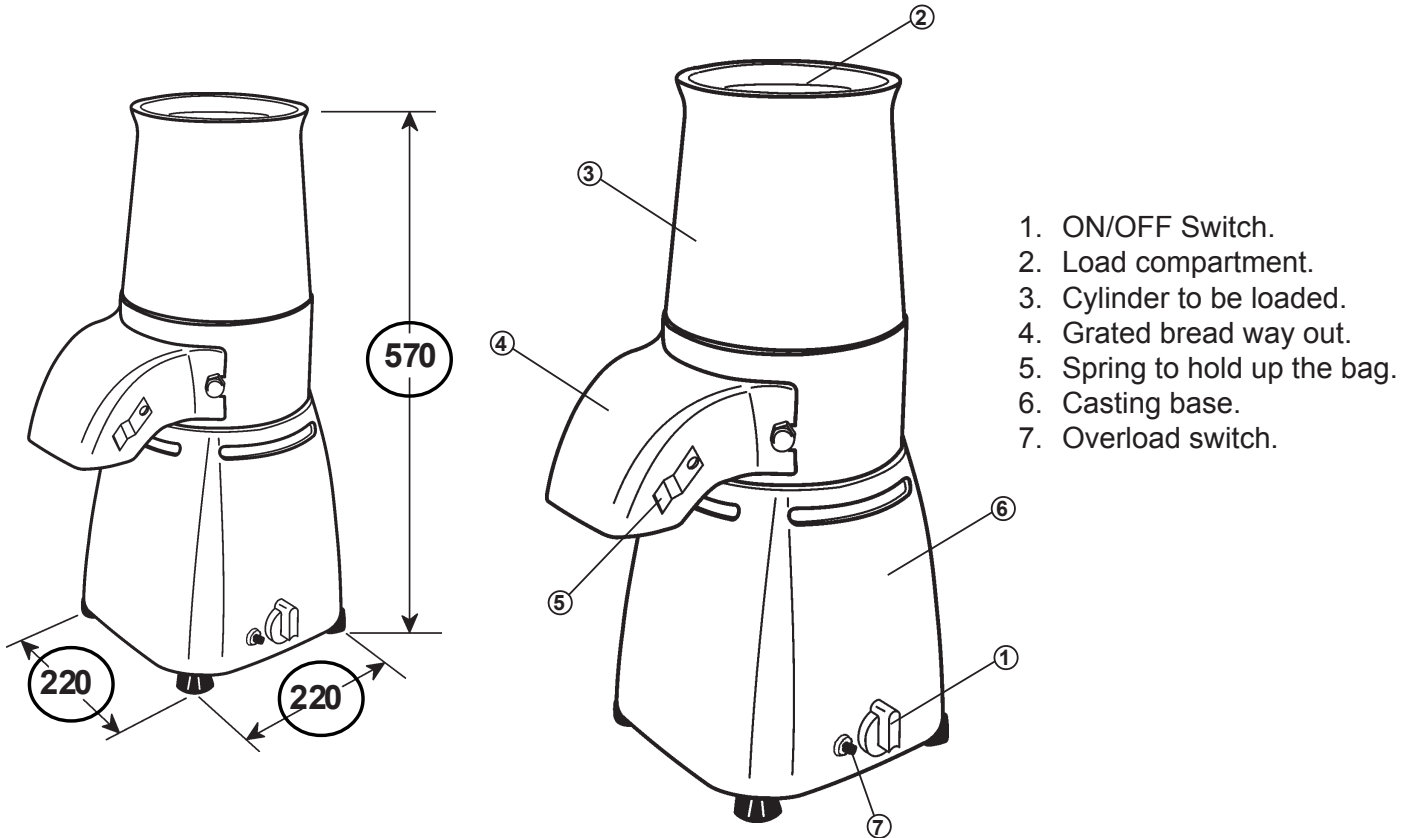

Model	GR-IT-0080	GR-IT-0080-S
Power	1.5 HP / 1.12 kW	
Electrical	110 V / 60 Hz / 1	
Weight	37.4 lbs. / 17 kg.	
Dimensions (DWH)	9.8" x 9.8" x 22.4" / 249.9 x 249.9 x 570mm	
Item Number	11411	*23865

*comes with extra safety features.

Installation

UNPACKING

Immediately after unpacking the machine, check it for possible shipping damage. If this machine is found to be damaged after unpacking, save the packing material and contact the carrier.

Installation

Prior to installation, test the electrical service to assure that it agrees with the specifications on the machine data plate.

ELECTRICAL

WARNING: This machine is provided with this plug,  this plug must be connected to a properly grounded outlet. If the receptacle is not the proper grounding type, contact an electrician.

Operation

IMPORTANT

Very easy to operate: once started you only need to put into the filler your dry bread to grate it fine and homogeneous.

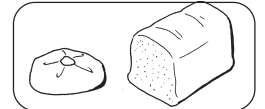

HOW TO LOAD THE PRODUCT TO BE CUT

Bread can be put in the machine also when grater is operating.

1. Place a bag on the specific tongs to collect grated bread.
2. Put and drop bread in the cylinder hollow.
3. Place the switch on 0 position.
4. Take away the bag where grated bread has been collected.

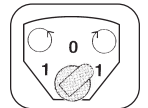
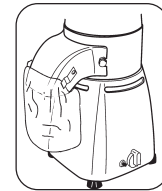

WARNING

In case of a blockage to the motor follow these instructions:

1. Turn the switch to the 0 position.
2. Turn it to the reverse position and keep it just few seconds in this position: the direction of rotation is reversed, unblocking it.
3. Turn the switch to the 1 position to restart the normal operation. If the motor continues to block, repeat the instructions from 1 to 3 until the machine operates normally.

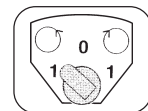
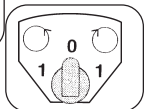
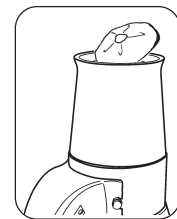

When the grating operation is finished switch off the toggle placing it on 0 position.

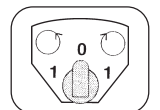

OVERLOAD SWITCH

The machine is equipped with an overload switch that protects the motor in the event of any undue stress as a prolonged blockage of the motor.

The overload switch switches off the power and stops the machine.

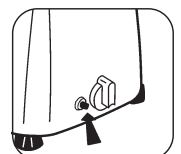

Operation

To restart the machine it is necessary to:

1. Place the machine on its side; the overload switch is on the lower section.
2. Re-position the switch to 0.
3. Disconnect the machine from the main supply.
4. Remove the cause of the blockage.
5. Wait approximately 10 sec.
6. Push the push button to reactivate the motor protector.
7. Restart the machine.

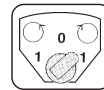
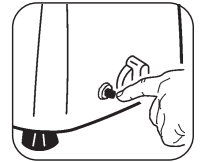
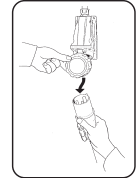
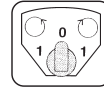

Maintenance

CLEANING

The materials utilized, anodized aluminium, stainless steel and plastics have been selected with due regard to hygiene regulations: "Rule CE n. 1935/2004 for the materials and things destined to come into contact with food".

WARNING: disconnect machine from socket.

1. Loosen both cylindrical loading filler screws.
2. Lift cylindrical loading filler by tilting it slightly forward.
3. Loosen both fixing screws.
4. Extract drain from screws.
5. Use a brush to clean crumbling powder and if necessary an aspirator.

Maintenance



Maintenance

This machine must be thoroughly cleaned and sanitized after installation and before being put into service.

ASSEMBLING

1. Reallocate drain between screws.
2. Fasten both fixing screws.
3. Allocate cylindrical filler by tilting it forward.
4. Fasten filler cylindrical locking screws.



1



2



3



4

Parts Breakdown

Model GR-IT-0080 11411

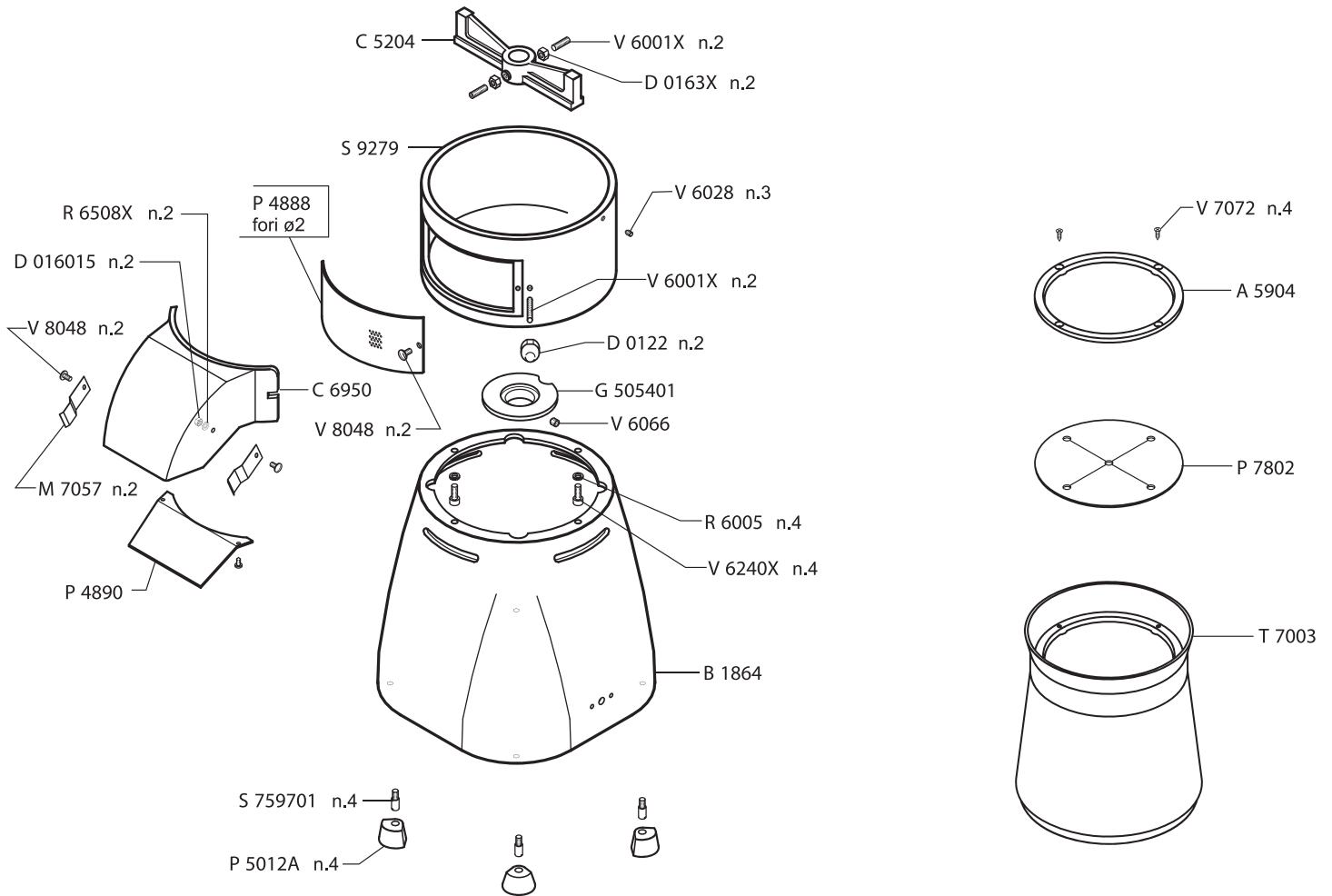

Parts Breakdown

Model GR-IT-0080 11411

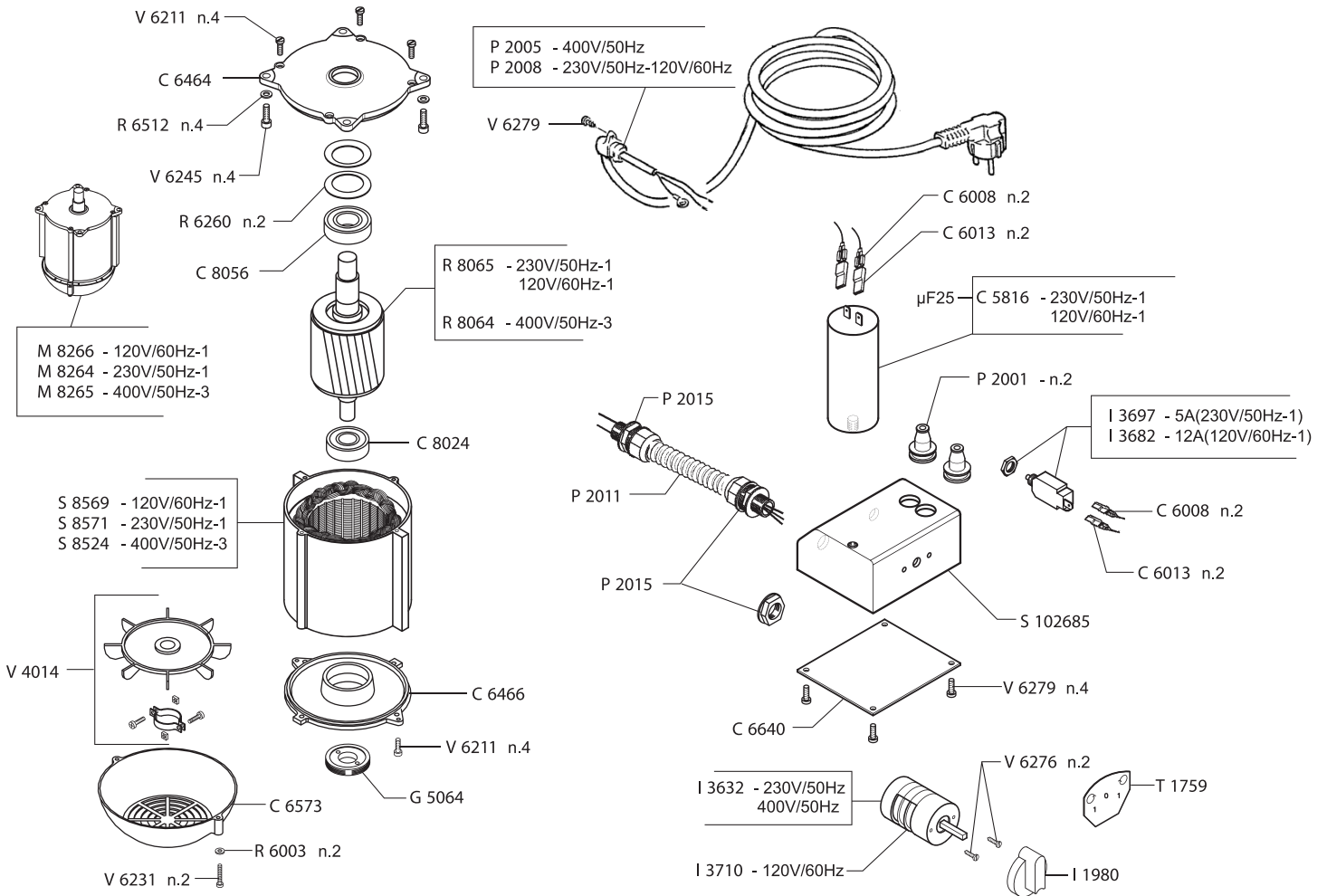

Parts Breakdown

Model GR-IT-0080 11411

Item No.	Description	Position	Item No.	Description	Position	Item No.	Description	Position
36542	M20 Cover Ring for BG80	A5904	16942	Switch for M2 for BG80	I3682	36903	Box Interruttore M20 for BG80	S102685
74399	Base for BG80	B1864	20461	Switch for M20 for BG80	I3710	36929	Pin D.8 M6 L.26 for BG80	S759701
17322	Knife for BG80	C5204	19784	Clip for BG80	M7057	36933	Statore H.80 120/60(TUBO ESTR.135) for BG80	S8569
17326	Capacitor 25MF 400V for BG80	C5816	36756	Motor 120/60 (ESTR.135) for BG80	M8266	36975	Motor Support M20 for BG80	S9279
36611	Connector L=19 for BG80	C6008	36774	Strain Relief for BG80	P2001	36989	Switch Pad Panel for BG80	T1759
36612	Connector L=23 for BG80	C6013	17415	Strain Relief for BG80	P2008	36995	Tramoggia for BG80	T7003
36614	Cover Anter.Motor H (Diam.135) for BG80	C6464	74413	Cable Sheath Cavoflex CM 60 for BG80	P2011	37013	Motor Fand MEC80 148x16 for BG80	V4014
36617	Motor Fan Cover for BG80	C6573	36779	Core-Hitch + Nut for BG80	P2015	37015	Screw STTC U6113 M6x20 Stainless Steel for BG80	V6001X
36620	Cover Box Interruttore M20N for BG80	C6640	36837	Flatbed Truck for Filter M20-M20E for BG80	P4888	37020	Screw M5x8 U5923 for BG80	V6028
36627	Corpo Bocca for BG80	C6950	36838	Piattina per Corpo Bocca M20 for BG80	P4890	19691	Grub Screw M6*6 for BG80	V6066
16925	Bearing 2RS-6204 20x47x14 for BG80	C8024	17435	Foot TS8/12/22 for BG80	P5012A	19697	Screw M5*16 for BG80	V6211
36631	Bearing 2RS-6205 25x52x15 for BG80	C8056	19176	Protector for BG80	P7802	19699	Screw M4*25 for BG80	V6231
36640	Domed Nut U5721 M6 Stainless Steel for BG80	D0153X	19657	Washer 4 for BG80	R6003	37037	Screw TCEI U5931 M6x16	V6240X
36644	U5588 M5 Stainless Steel Nut for BG80	D016015	19658	Washer 6 for BG80	R6005	19701	Screw M6*20 for BG80	V6245
36646	Nut U5588 M6 Stainless Steel for BG80	D0163X	19665	Washer for BG80	R6260	37047	Screw TC AUT.D7971 2.9x13 for BG80	V6276
36693	Ring for Motor M20-M20E for BG80	G505401	36882	Washer U6592 5 Stainless Steel for BG80	R6508X	37048	Screw TCTC AUT.D7981 3.5x9.5 for BG80	V6279
36697	Logging Lock Nut GL25 for BG80	G5064	17457	Washer U6592 6 Stainless Steel for BG80	R6512-X	37087	Screw TSPTC AUT.U6955 3.5x14 for BG80	V7072
36707	Switch Handle for BG80	I1980	36898	Rotor(A3125 P2523)M20-M20N 230/50 for BG80	R8065	37106	Stainless Steel Switch Screw M5x10 for BG80	V8048

Parts Breakdown

Model GR-IT-0080-S 23865

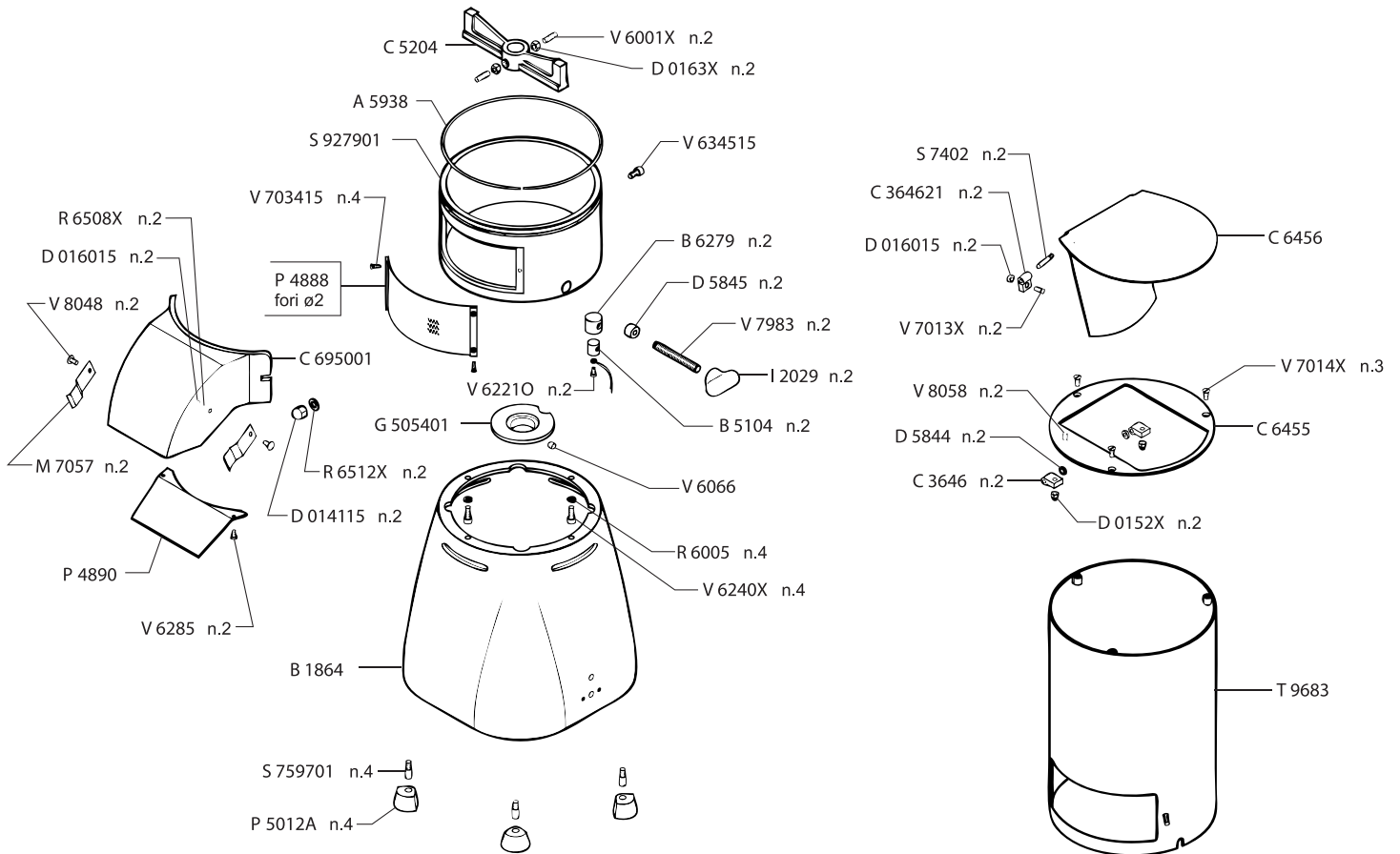

Parts Breakdown

Model GR-IT-0080-S 23865

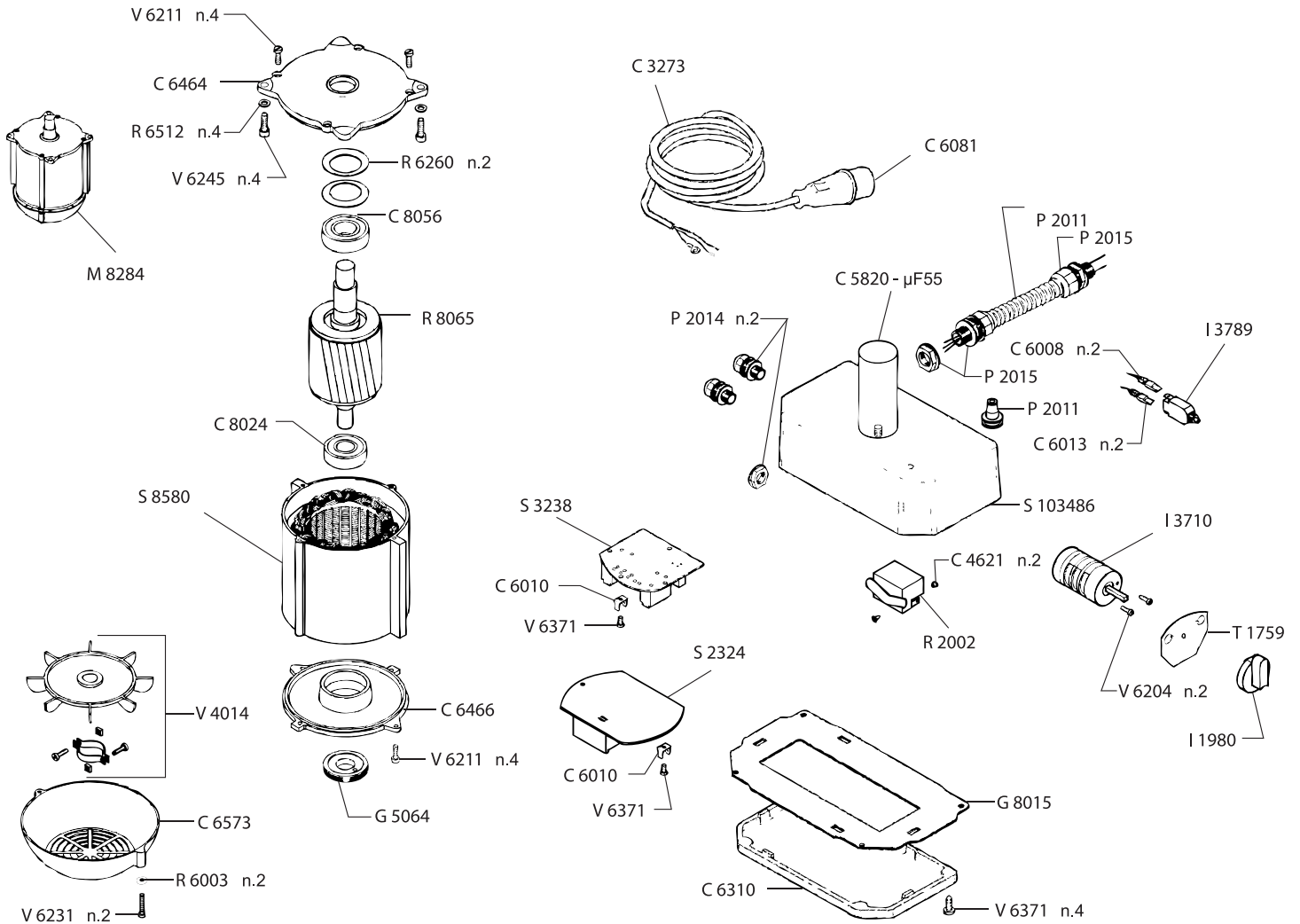

Parts Breakdown

Model GR-IT-0080-S 23865

Item No.	Description	Position	Item No.	Description	Position	Item No.	Description	Position
74398	Anello Adattatore Øe 200 Filo Ø4 for BG80E	A5938	36646	Nut U5588 M6 Stainless Steel for BG80E	D0163X	36898	Rotor(A3125 P2523)M20-M20N 230/50 for BG80E	R8065
74399	Base for BG80E	B1864	74409	Spacer Cover Mobile M20E for BG80E	D5844	44921	Electrical Box for BG80E	S103486
74400	Block Ferma Cavo Micro M20E for BG80E	B5104	74410	Spacer Isolante 6x15x10 M20N for BG80E	D5845	36911	Pin 5x28 for BG80E	S7402
74401	Bushing Isolante Block M20E for BG80E	B6279	36693	Ring for Motor M20-M20E for BG80E	G505401	36929	Pin D.8 M6 L.26 for BG80E	S759701
36597	Power Cord 2P+T 15A 125V for BG80E	C3273	36697	Logging Lock Nut GL25 for BG80E	G5064	74414	Stator H.80 120/60(ESTR.135) for BG80E	S8580
36598	Cerniera Porta T210-T250 for BG80E	C3646	74411	Seal for BG80E	G8015	74415	Supporto Motor M20E for BG80E	S927901
36599	Rivet 3.85 for BG80E	C4621	36707	Switch Handle for BG80E	I1980	36989	Switch Pad Panel for BG80E	T1759
17322	Knife for M2 for BG80E	C5204	74412	Knife Holder Fastener Knob for BG80E	I2029	74416	Tube Macinapane for BG80E	T9683
31214	Capacitor for BG80E	C5820	20461	Switch for M20 for BG80E	I3710	37013	Motor Fan MEC80 148x16 for BG80E	V4014
36611	Connector L=19 for BG80E	C6008	44920	Microswitch for BG80E	I3789	37015	Screw STTC U6113 M6x20 Stainless Steel for BG80E	V6001X
74403	Connector Faston 2 Poles Male for BG80E	C6010	19784	Clip for BG80E	M7057	19691	Grub Screw M6*6 for BG80E	V6066
36612	Connector L=23 for BG80E	C6013	44923	Motor for BG80E	OMZZM8284	19696	Screw M3.5*12 for BG80E	V6204
77609	Connettore Spina Monofase 2x16A CEE for BG80E	C6081	74413	Cable Sheath Cavoflex CM 60 for BG80E	P2011	19697	Screw M5*16 for BG80E	V6211
74404	Cover for S1024 Box for BG80E	C6310	36778	Wire-Press for BG80E	P2014	19699	Screw M4*25 for BG80E	V6231
74405	Cover Fisso Macinapane M20E for BG80E	C6455	36779	Core-Hitch + Nut for BG80E	P2015	19700	Screw M6*16 for BG80E	V6240
74406	Cover Mobile Macinapane M20E for BG80E	C6456	36837	Flatbed Truck for Filter M20-M20E for BG80E	P4888	19701	Screw M6*20 for BG80E	V6245
36614	Cover Anter.Motor H (Diam.135) for BG80E	C6464	36838	Piattina per Corpo Bocca M20 for BG80E	P4890	37050	Screw TC AUT.D7971 4.2x9 for BG80E	V6285
36615	H-C Series Back Motor Cover for BG80E	C6466	17435	Foot TS8/12/22 for BG80E	P5012A	37056	Stainless Steel Screw M6x12 U5931 for BG80E	V634515
36617	Motor Fan Cover for BG80E	C6573	16965	Relay 11.8A 4CR-708 for BG80E	R2002	37059	Stainless Steel Screw M4x14 for BG80E	V6371
74407	Corpo Bocca for BG80E	C695001	19657	Washer 4 for BG80E	R6003	37078	Stainless Steel Screw TSP U6109 M5x12 for BG80E	V7013X
16925	Bearing 2RS-6204 20x47x14 for BG80E	C8024	19658	Washer 6 for BG80E	R6005	17497	Screw TSP U6109 M5x15 Stainless Steel for BG80E	V7014X
36631	Bearing 2RS-6205 25x52x15 for BG80E	C8056	19665	Washer for BG80E	R6260	74418	Vite TSP U6109 M4x8 INOX for BG80E	V703415
74408	Stainless Steel Nut DIN 917 M6 for BG80E	D014115	36882	Washer U6592 5 Stainless Steel for BG80E	R6508X	74419	Screw for BG80E	V7983
36639	Nut U5721 M5 Stainless Steel for BG80E	D0152X	16966	On Hold for BG80E	R6512	37106	Stainless Steel Switch Screw M5x10	V8048
36644	U5588 M5 Stainless Steel Nut for BG80E	D016015	17457	Washer U6592 6 Stainless Steel for BG80E	R6512-X			

Electrical Schematics

Model GR-IT-0080 11411

Model GR-IT-0080-S 23865

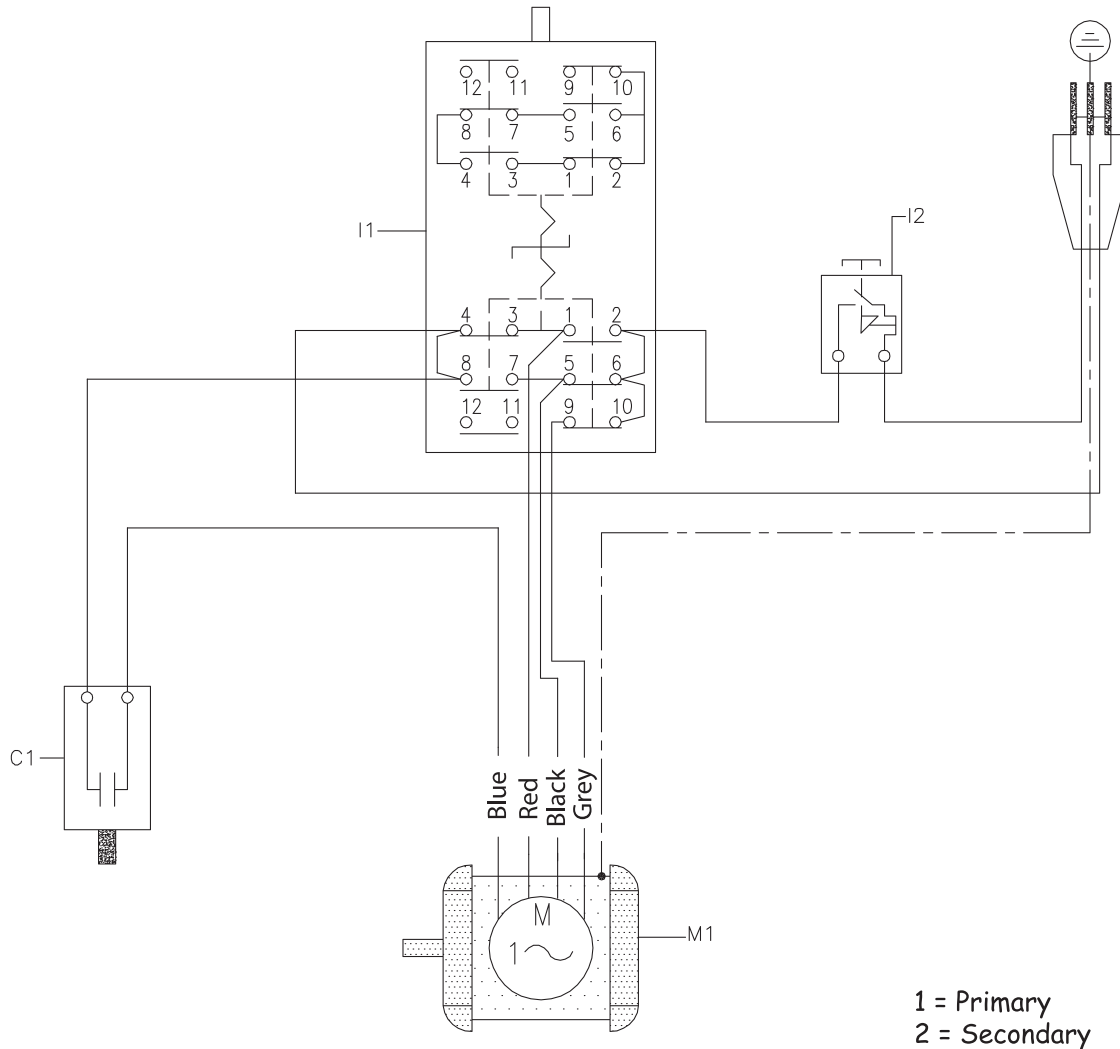

POS.	DESCRIPTION
C1	CAPACITOR 25 μ F 450V
I1	INVERTER
I2	OVERLOAD 5A 230V/50Hz
I2	OVERLOAD 12A 120V/60Hz
M1	MOTOR



Warranty Registration

Thank you for purchasing an Omcan product. To register your warranty for this product, complete the information below, tear off the card at the perforation and then send to the address specified below. You can also register online by visiting:

Merci d'avoir acheté un produit Omcan. Pour enregistrer votre garantie pour ce produit, complétez les informations ci-dessous, détachez la carte au niveau de la perforation, puis l'envoyer à l'adresse spécifiée ci-dessous. Vous pouvez également vous inscrire en ligne en visitant:

Gracias por comprar un producto Omcan usted. Para registrar su garantía para este producto, complete la información a continuación, cortar la tarjeta en la perforación y luego enviarlo a la dirección indicada a continuación. También puede registrarse en línea en:

www.omcan.com/warrantyregistration.html

For mailing in Canada

Pour postale au Canada

Por correo en Canadá

OMCAN

PRODUCT WARRANTY REGISTRATION

3115 Pepper Mill Court,

Mississauga, Ontario

Canada, L5L 4X5

For mailing in the US

Pour diffusion aux États-Unis

Por correo en los EE.UU.

OMCAN

PRODUCT WARRANTY REGISTRATION

4450 Witmer Industrial Estates, Unit 4,

Niagara Falls, New York

USA, 14305

or email to: service@omcan.com



Purchaser's Information

Name: _____

Address: _____

City: _____ Province or State: _____ Postal or Zip: _____

Country: _____

Dealer from which Purchased: _____

Dealer City: _____ Dealer Province or State: _____

Invoice: _____

Model Name: _____ Model Number: _____

Machine Description: _____

Date of Purchase (MM/DD/YYYY): _____

Would you like to extend the warranty? Yes No

Company Name: _____

Telephone: _____

Email Address: _____

Type of Company:

Restaurant Bakery Deli

Butcher Supermarket Caterer

Institution (*specify*): _____

Other (*specify*): _____

Serial Number: _____

Date of Installation (MM/DD/YYYY): _____

Thank you for choosing Omcan | Merci d'avoir choisi Omcan | Gracias por elegir Omcan



Since 1951 Omcan has grown to become a leading distributor of equipment and supplies to the North American food service industry. Our success over these many years can be attributed to our commitment to strengthen and develop new and existing relationships with our valued customers and manufacturers. Today with partners in North America, Europe, Asia and South America, we continually work to improve and grow the company. We strive to offer customers exceptional value through our qualified local sales and service representatives who provide convenient access to over 3,500 globally sourced products.

Depuis 1951 Omcan a grandi pour devenir un des “leaders” de la distribution des équipements et matériel pour l’industrie des services alimentaires en Amérique du Nord. Notre succès au cours de ces nombreuses années peut être attribué à notre engagement à renforcer et à développer de nouvelles et existantes relations avec nos clients et les fabricants de valeur. Aujourd’hui avec des partenaires en Amérique du Nord, Europe, Asie et Amérique du Sud, nous travaillons continuellement à améliorer et développer l’entreprise. Nous nous efforçons d’offrir à nos clients une valeur exceptionnelle grâce à nos ventes locales qualifiées et des représentants de service qui offrent un accès facile à plus de 3500 produits provenant du monde entier.

Desde 1951 Omcan ha crecido hasta convertirse en un líder en la distribución de equipos y suministros de alimentos en América del Norte industria de servicios. Nuestro éxito en estos años se puede atribuir a nuestro compromiso de fortalecer y desarrollar nuevas relaciones existentes con nuestros valiosos clientes y fabricantes. Hoy con socios de América del Norte, Europa, Asia y América del Sur, que trabajan continuamente para mejorar y crecer la empresa. Nos esforzamos por ofrecer a nuestros clientes valor excepcional a través de nuestro local de ventas y representantes de los servicios que proporcionan un fácil acceso a más de 3,500 productos con origen a nivel mundial.

