



## Slush Machines

Models DI-IT-0010-S, 0020-S, 0030-S  
Items 39677, 39678, 39679  
**Instruction Manual**



**STOP**  
**DO NOT RETURN**  
**THIS PRODUCT TO THE STORE**

For questions or assistance with this product call OMCAN Toll Free: 1 800 465 0234  
Customer Service  
or  
visit the Support section of [www.omcan.com](http://www.omcan.com)

Revised - 02/24/2020



Toll Free: 1-800-465-0234  
Fax: 905-607-0234  
Email: [service@omcan.com](mailto:service@omcan.com)  
[www.omcan.com](http://www.omcan.com)

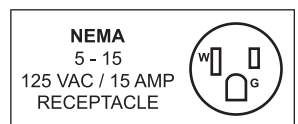

# ***Table of Contents***

Model DI-IT-0010-S / Model DI-IT-0020-S / Model DI-IT-0030-S

---

<b>Section</b>	<b>Page</b>
General Information -----	3 - 4
Safety and Warranty -----	4 - 5
Technical Specifications -----	6
Installation -----	6
Operation -----	6 - 7
Maintenance -----	8
Figure Drawings -----	9
Parts Breakdown -----	10 - 13
Electrical Schematics -----	14
Warranty Registration -----	15



# General Information

---

Omcan Manufacturing and Distributing Company Inc., Food Machinery of America, Inc. dba Omcan and Omcan Inc. are not responsible for any harm or injury caused due to any person's improper or negligent use of this equipment. The product shall only be operated by someone over the age of 18, of sound mind, and not under the influence of any drugs or alcohol, who has been trained in the correct operation of this machine, and is wearing authorized, proper safety clothing. Any modification to the machine voids any warranty, and may cause harm to individuals using the machine or in the vicinity of the machine while in operation.

## CHECK PACKAGE UPON ARRIVAL

Upon receipt of an Omcan shipment please inspect for external damage. If no damage is evident on the external packaging, open carton to ensure all ordered items are within the box, and there is no concealed damage to the machine. If the package has suffered rough handling, bumps or damage (visible or concealed), please note it on the bill of lading before accepting the delivery and contact Omcan within 24 hours, so we may initiate a claim with the carrier. A detailed report on the extent of the damage caused to the machine must be filled out within three days, from the delivery date shown in the shipping documents. Omcan has no recourse for damaged products that were shipped collect or third party.

**Before operating any equipment, always read and familiarize yourself with all operation and safety instructions.**

Omcan would like to thank you for purchasing this machine. It's of the utmost importance to save these instructions for future reference. Also save the original box and packaging for shipping the equipment if servicing or returning of the machine is required.

---

Omcan Fabrication et distribution Compañie Limité et Food Machinery d'Amérique, dba Omcan et Omcan Inc. ne sont pas responsables de tout dommage ou blessure causé du fait que toute personne ait utilisé cet équipement de façon irrégulière. Le produit ne doit être exploité que par quelqu'un de plus de 18 ans, saine d'esprit, et pas sous l'influence d'une drogue ou d'alcool, qui a été formé pour utiliser cette machine correctement, et est vêtu de vêtements de sécurité approprié. Toute modification de la machine annule toute garantie, et peut causer un préjudice à des personnes utilisant la machine ou des personnes à proximité de la machine pendant son fonctionnement.

## VÉRIFIEZ LE COLIS DÈS RÉCEPTION

Dès réception d'une expédition d'Omcan veuillez inspecter pour dommages externes. Si aucun dommage n'est visible sur l'emballage externe, ouvrez le carton afin de s'assurer que tous les éléments commandés sont dans la boîte, et il n'y a aucun dommage dissimulé à la machine. Si le colis n'a subi aucune mauvaises manipulations, de bosses ou de dommages (visible ou cachée), notez-le sur le bond de livraison avant d'accepter la livraison et contactez Omcan dans les 24 heures qui suivent, pour que nous puissions engager une réclamation auprès du transporteur. Un rapport détaillé sur l'étendue des dommages causés à la machine doit être rempli dans un délai de trois jours, à compter de la date de livraison indiquée dans les documents d'expédition. Omcan n'a aucun droit de recours pour les produits endommagés qui ont été expédiés ou cueilli par un tiers transporteur.

# General Information

---

Avant d'utiliser n'importe quel équipement, toujours lire et vous familiariser avec toutes les opérations et les consignes de sécurité.

Omcan voudrais vous remercier d'avoir choisi cette machine. Il est primordial de conserver ces instructions pour une référence ultérieure. Également conservez la boîte originale et l'emballage pour l'expédition de l'équipement si l'entretien ou le retour de la machine est nécessaire.

---

Omcan Empresa De Fabricacion Y Distribucion Inc. Y Maquinaria De Alimentos De America, Inc. dba Omcan y Omcan Inc. no son responsables de ningun daño o perjuicio causado por cualquier persona inadecuada o el uso descuidado de este equipo. El producto solo podra ser operado por una persona mayor de 18 años, en su sano juicio y no bajo alguna influencia de droga o alcohol, y que este ha sido entrenado en el correcto funcionamiento de esta máquina, y ésta usando ropa apropiada y autorizada. Cualquier modificación a la máquina anula la garantía y puede causar daños a las personas usando la máquina mientras esta en el funcionamiento.

## REVISE EL PAQUETE A SU LLEGADA

Tras la recepcion de un envio Omcan favor inspeccionar daños externos. Si no hay daños evidentes en el empaque exterior, Habra el carton para asegurarse que todos los articulos solicitados estén dentro de la caja y no encuentre daños ocultos en la máquina. Si el paquete ha sufrido un manejo de poco cuidado, golpes o daños (visible o oculto) por favor anote en la factura antes de aceptar la entrega y contacte Omcan dentro de las 24 horas, de modo que podamos iniciar una reclamación con la compañía. Un informe detallado sobre los daños causados a la máquina debe ser llenado en el plazo de tres días, desde la fecha de entrega que se muestra en los documentos de envío. Omcan no tiene ningun recurso por productos dañados que se enviaron a recoger por terceros.

Antes de utilizar cualquier equipo, siempre lea y familiarizarse con todas las instrucciones de funcionamiento y seguridad.

Omcan le gustaría darle las gracias por la compra de esta máquina. Es de la mayor importancia para salvar estas instrucciones para futuras consultas. Además, guarda la caja original y el embalaje para el envío del equipo si servicio técnico o devolución de la máquina que se requiere.

# Safety and Warranty

---

## USEFUL INFORMATION

- Do not pour hot mixture into the containers.
- To increase slurry production, top up with fresh mixture as opposed to leaving the evaporator uncovered during operation.
- During operation, it is normal that the machine emits heat. Should this heat appear excessive, check that the condenser is not obstructed by dust (see relative condenser cleaning section), or that the machine is

# *Safety and Warranty*

---

not positioned close to a heat source (see installation section).

- Ensure that the product sugar content is within the 15% – 25% limit when preparing the mixture. Lower levels will inhibit slurry production due to the reduction motor protection system, while higher levels will result in delays due to the higher sugar content corresponding to a lower freezing point.
- To ensure that flavours remain unaltered, clean all components that are in direct contact with the product at least every two days.
- Should the type of product be changed, empty the container(s) and pour in hot water and leave to stand. Wait 15 minutes before emptying. Do not use the refrigeration cycle during this period.

## **PRINCIPAL RULES**

- Do not touch the machine with wet hands.
- Do not use the equipment barefoot.
- Do not permit incapable persons or children to operate the machine.
- Do not leave the equipment outdoors or otherwise exposed to the elements.

## **1 YEAR PARTS AND LABOUR BENCH WARRANTY**

**Within the warranty period, contact Omcan Inc. at 1-800-465-0234 to schedule an Omcan authorized service technician to repair the equipment locally.**

**Unauthorized maintenance will void the warranty. Warranty covers electrical and part failures, not improper use.**

**Please see <https://omcan.com/disclaimer> for complete info.**

## **WARNING:**

The packaging components are classified as normal solid urban waste and can therefore be disposed of without difficulty.

**In any case, for suitable recycling, we suggest disposing of the products separately (differentiated waste) according to the current norms.**

**DO NOT DISCARD ANY PACKAGING MATERIALS IN THE ENVIRONMENT!**

# Technical Specifications

Model	DI-IT-0010-S	DI-IT-0020-S	DI-IT-0030-S
Capacity	10 L / 2.7 Gal	10 L / 2.7 Gal (x2)	10 L / 2.7 Gal (x3)
Temperature	Up to -6°C / 21°F		
Electrical	115V / 60Hz / 1Ph		
Power	920W	1150W	1300W
Refrigerant	R404		
Current	8A	10A	11.3A
Dimensions	7" x 24" x 32" 178 x 610 x 813mm	14" x 24" x 32" 356 x 610 x 813mm	20" x 24" x 32" 508 x 610 x 813mm
Weight	66 lbs. / 29.9 kgs.	110 lbs. / 49.9 kgs.	149 lbs. / 67.6 kgs.
Item Number	39677	39678	39679

## Installation

### INSTRUCTIONS AND WARNINGS

Remove the machine from the packing, and check for any visible signs of damage that may have occurred during shipping. Remove the protective coverings (plastic bags, etc.) and ensure that they are stored out of the reach of children. The equipment must never be lifted by the glass or plastic components when being moved; the company shall not be held responsible for damage caused by improper handling. Check that the power supply is adequately grounded as required by law, and corresponds to the power specifications printed on the equipment placard situated on the front panel or printed in the manual. Do not use multiple adapters: the equipment must be connected to a single outlet. If in doubt, have the machine installed by a qualified technician. The company declines any responsibility for accidents due to an incorrect installation resulting in damage to persons or property. Before operating the equipment, clean as per the instructions in the Cleaning and Maintenance section. Install the equipment away from heat sources and leave sufficient space around the machine to ensure adequate cooling by air circulation.

**CAUTION: If the containers remain full overnight, blocks of ice may form. Before switching the machine on, clear any ice from inside the containers to avoid damage to the paddles.**

## Operation

Before filling the containers, carefully clean and rinse all surfaces that will be exposed to the drinks. Fill the containers up to the maximum level and replace the illuminated covers.

**CAUTION The equipment is not designed for sugar-free liquids. If natural products are used, the sugar**

# Operation

content must be between 15% and 25%. If commercial mixes are used for slurries, sorbets, yoghurt or milk-based drinks, follow the manufacturer's instructions.

- Move Power Switch (8) to ON.
- Press the reduction motor button (6).
- Press the Bibita (Drinks) button (4) for cold drinks, or the Granita (Slurry) button (5) for slurries.
- Drink temperature or Slurry density may be raised or lowered by using buttons (1) or (2) accordingly. The density reference or the temperature in degrees C may be read from the display.
- Cover lights are operated by button (7).

## EQUIPMENT FUNCTIONS

### KEYPAD LEGEND

1. Decrease slurry density.  
Decrease drink temperature.
2. Increase slurry density.  
Increase drink temperature.
3. Display:  
Slurry function: 1- 3 - 5 - 7 - 9 indicates slurry density, indicates valve open.  
Drinks function: 4°C - 9°C drink temperature, H° drink temperature higher than 9°C, L° drink temperature lower than 4°C
4. Cold drink function.
5. Slurry function.
6. Reduction motor (press ON/OFF).
7. Cover lights (press ON/OFF).

The machine memorizes the last selected settings when switched off for any length of time. The cover lights may be switched on or off as required by using the appropriate button. If sugar content is insufficient, or foreign bodies or blocks of ice are detected in a container, a sensor will halt paddle rotation so as not to overload the reduction motor. The display will show an error symbol (Γ). Once the cause of the stoppage has been rectified, replace the cover, press reduction motor button (6), and either the drinks (4) or slurry (5) button, and the machine will restart.

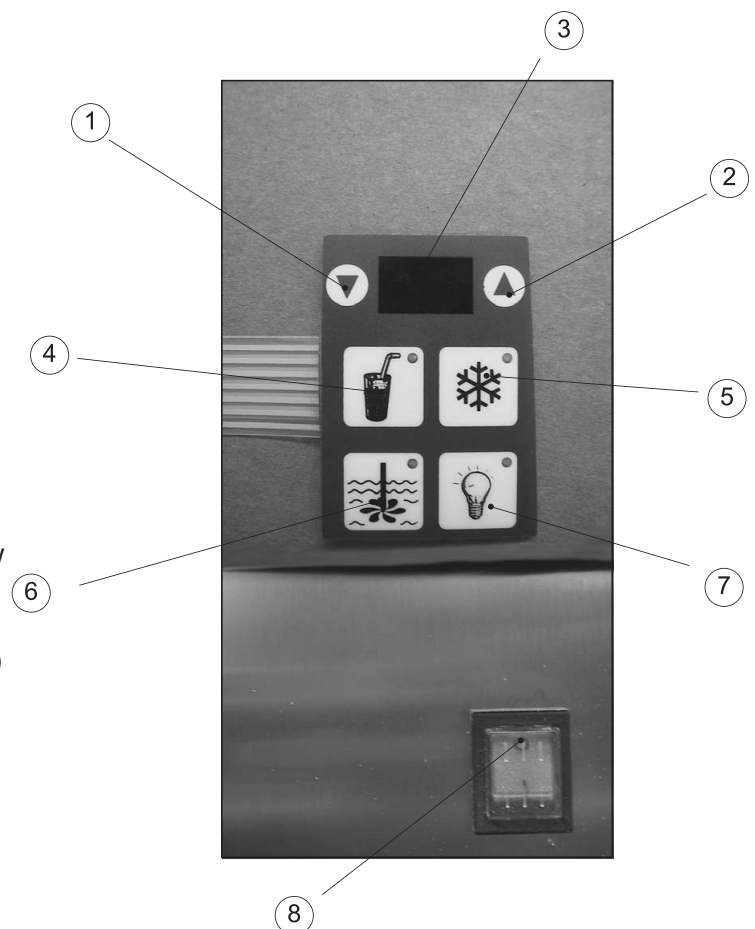

# Maintenance

## CLEANING AND MAINTENANCE

**CAUTION:** Before attempting any cleaning or maintenance, ensure that the power switch is OFF, and that the plug is removed from the mains. Never remove the plug by pulling the power cable (Fig. A).

It is imperative that machine components having direct contact with the products are cleaned thoroughly. Carry out cleaning as per the illustration.

- Remove the illuminated cover.
- Empty the containers.
- Fill containers to remove product residue and rinse out.
- After extracting the base-container pin (Fig. C), Remove containers as shown in Fig. B.
- Remove paddle, internal shaft, and the lower sprocket (Fig. D), and then remove the container gasket (Fig. E).
- Disassemble the tap (Fig. F) by pulling the two pins from the lever (Fig. G) and turning the locking ring anti-clockwise (Fig. H).
- Unscrew the threaded knob and extract the upper sprocket (Fig. I – L).
- Extract the main gear rack by pulling upwards (Fig. M).
- Wash all components using a suitable detergent and rinse. Do not use abrasive cleaning products.
- Assemble all the previously removed components in reverse order as per the illustrations, and check for correct operation.

**Illuminated covers must be in position before the machine will operate. The containers may now be refilled.**

## CLEANING THE CONDENSER (RADIATOR)

All equipment of this type tends to ingest airborne dust when operating. This dust accumulates on the condenser inlet surfaces, and should be removed with a soft, dry brush (Fig. N). A condenser clogged by dust will compromise efficient refrigeration system operation, increase power consumption, and may be the precursor of serious damage.

## REFERENCE

Item Number	Model Number	Description	Manufacturer Model Number
39677	DI-IT-0010-S	Slush Machine Mod Grani 10 L 1 Bowl 115/60 Black ETL	GR1
39678	DI-IT-0020-S	Slush Machine Mod Grani 10 L 2 Bowl 115/60 Black ETL	GR2
39679	DI-IT-0030-S	Slush Machine Mod Grani 10 L 3 Bowl 115/60 Black ETL	GR3

# Figure Drawings



Fig.A

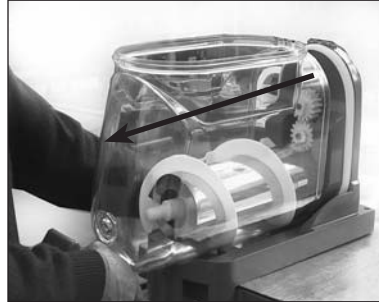

Fig.B



Fig.C

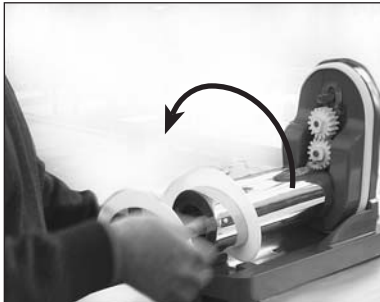

Fig.D



Fig.E



Fig.F



Fig.G



Fig.H



Fig.I



Fig.L



Fig.M



Fig.N

# Parts Breakdown

**Model DI-IT-0010-S** 39677

**Model DI-IT-0020-S** 39678

**Model DI-IT-0030-S** 39679

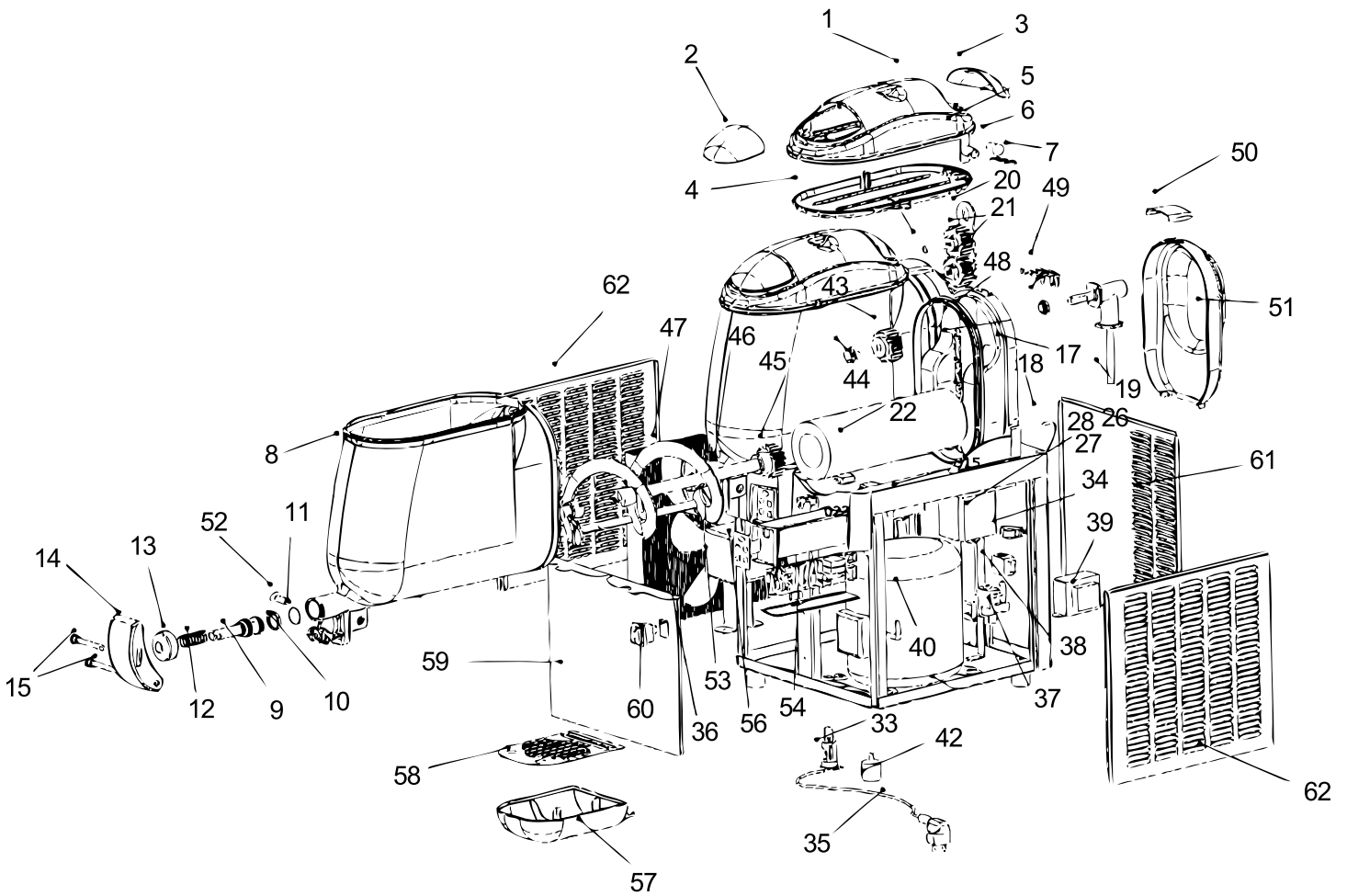

# Parts Breakdown

## Model DI-IT-0010-S 39677

Item No.	Description	Position	Item No.	Description	Position	Item No.	Description	Position
70748	Lid for GR1	1	70767	Base for GR1	23	70783	Lower Sprocket for GR1	45
70749	Front Glass for GR1	2	70768	Gasket Front Evaporator for GR1	24	42901	Propeller Shaft for GR1	46
70750	Rear Glass for GR1	3	70769	Gasket Rear Evaporator for GR1	25	42902	Spiral for GR1	47
70751	Inner Cover for GR1	4	70770	Reduction Motor for GR1	26	42903	Tank Basket for GR1	48
70752	Light-Bulb Holder for GR1	5	70771	Bakelite Gear for GR1	27	61395	Shoulder Electrical Contacts for GR1	49
70753	Light-Bulb for GR1	6	70772	Sinterizate Gear for GR1	28	70785	Electrical Contact Cover for GR1	50
70754	Lid Electrical Contacts for GR1	7	70773	Base Plug for GR1	29	70786	Shoulder Cover for GR1	51
42897	Container for GR1	8	70774	Metal Hook Tank Safety Pin for GR1	30	70787	Tank Safety Pin for GR1	52
70755	Tap Piston for GR1	9	70775	Evaporator Swab for GR1	31	70800	Fan for GR1	53
42898	Basket with Lip for GR1	10	70776	Gear Slide Pin for GR1	32	70788	Electrical Circuit Board for GR1	54
42899	Or Tap for GR1	11	70777	Cable Lock for GR1	33	70789	Circuit Board Cover for GR1	55
70756	Piston Spring for GR1	12	42900	Reduction Motor Sensor for GR1	34	70790	Controls for GR1	56
70757	Tap Plug for GR1	13	70778	Electrical Cable for GR1	35	70791	Drip Tray for GR1	57
70758	Lever Tap for GR1	14	70795	Condenser for GR1	36	70792	Drip-Tray Grille in Plastic for GR1	58
70759	Lever Safety Pin (Lower) for GR1	15	70796	P.M. Electric Valve for GR1	37	70801	Front Panel for GR1	59
70760	Lever Safety Pin (Upper) for GR1	16	70797	Valve Coil for GR1	38	70793	Power Switch for GR1	60
70761	Shoulder for GR1	17	70798	Transformer for GR1	39	70802	Rear Panel for GR1	61
70762	Thermostat for GR1	18	70799	Compressor for GR1	40	70794	Side Panel for GR1	62
70763	Return for GR1	19	70779	Charge Valve for GR1	41	61396	Fuse for GR1	
70764	Gear Slide for GR1	20	70780	Feet for GR1	42	46405	Sensor for GR1	
70765	Main Gears for GR1	21	70781	Upper Sprocket for GR1	43	46406	Sensor Cover for GR1	
70766	Evaporator for GR1	22	70782	Threaded Knob for GR1	44	46407	Cable Sensor for GR1	

# Parts Breakdown

## Model DI-IT-0020-S 39678

Item No.	Description	Position	Item No.	Description	Position	Item No.	Description	Position
70748	Lid for GR2	1	70767	Base for GR2	23	70783	Lower Sprocket for GR2	45
70749	Front Glass for GR2	2	70768	Gasket Front Evaporator for GR2	24	42901	Propeller Shaft for GR2	46
70750	Rear Glass for GR2	3	70769	Gasket Rear Evaporator for GR2	25	42902	Spiral for GR2	47
70751	Inner Cover for GR2	4	70770	Reduction Motor for GR2	26	42903	Tank Basket for GR2	48
70752	Light-Bulb Holder for GR2	5	70771	Bakelite Gear for GR2	27	61395	Shoulder Electrical Contacts for GR2	49
70753	Light-Bulb for GR2	6	70772	Sinterizate Gear for GR2	28	70785	Electrical Contact Cover for GR2	50
70754	Lid Electrical Contacts for GR2	7	70773	Base Plug for GR2	29	70786	Shoulder Cover for GR2	51
42897	Container for GR2	8	70774	Metal Hook Tank Safety Pin for GR2	30	70787	Tank Safety Pin for GR2	52
70755	Tap Piston for GR2	9	70775	Evaporator Swab for GR2	31	70808	Fan for GR2	53
42898	Basket with Lip for GR2	10	70776	Gear Slide Pin for GR2	32	70788	Electrical Circuit Board for GR2	54
42899	Or Tap for GR2	11	70777	Cable Lock for GR2	33	70789	Circuit Board Cover for GR2	55
70756	Piston Spring for GR2	12	42900	Reduction Motor Sensor for GR2	34	70790	Controls for GR2	56
70757	Tap Plug for GR2	13	70778	Electrical Cable for GR2	35	70791	Drip Tray for GR2	57
70758	Lever Tap for GR2	14	70803	Condenser for GR2	36	70792	Drip-Tray Grille in Plastic for GR2	58
70759	Lever Safety Pin (Lower) for GR2	15	70804	P.M. Electric Valve for GR2	37	70809	Front Panel for GR2	59
70760	Lever Safety Pin (Upper) for GR2	16	70805	Valve Coil for GR2	38	70793	Power Switch for GR2	60
70761	Shoulder for GR2	17	70806	Transformer for GR2	39	70810	Rear Panel for GR2	61
70762	Thermostat for GR2	18	70807	Compressor for GR2	40	70794	Side Panel for GR2	62
70763	Return for GR2	19	70779	Charge Valve for GR2	41	61396	Fuse for GR2	
70764	Gear Slide for GR2	20	70780	Feet for GR2	42	46405	Sensor for GR2	
70765	Main Gears for GR2	21	70781	Upper Sprocket for GR2	43	46406	Sensor Cover for GR2	
70766	Evaporator for GR2	22	70782	Threaded Knob for GR2	44	46407	Cable Sensor for GR2	

# Parts Breakdown

## Model DI-IT-0030-S 39679

Item No.	Description	Position	Item No.	Description	Position	Item No.	Description	Position
70748	Lid for GR3	1	70767	Base for GR3	23	70783	Lower Sprocket for GR3	45
70749	Front Glass for GR3	2	70768	Gasket Front Evaporator for GR3	24	42901	Propeller Shaft for GR3	46
70750	Rear Glass for GR3	3	70769	Gasket Rear Evaporator for GR3	25	42902	Spiral for GR3	47
70751	Inner Cover for GR3	4	70770	Reduction Motor for GR3	26	42903	Tank Basket for GR3	48
70752	Light-Bulb Holder for GR3	5	70771	Bakelite Gear for GR3	27	61395	Shoulder Electrical Contacts for GR3	49
70753	Light-Bulb for GR3	6	70772	Sinterizate Gear for GR3	28	70785	Electrical Contact Cover for GR3	50
70754	Lid Electrical Contacts for GR3	7	70773	Base Plug for GR3	29	70786	Shoulder Cover for GR3	51
42897	Container for GR3	8	70774	Metal Hook Tank Safety Pin for GR3	30	70787	Tank Safety Pin for GR3	52
70755	Tap Piston for GR3	9	70775	Evaporator Swab for GR3	31	70816	Fan for GR3	53
42898	Basket with Lip for GR3	10	70776	Gear Slide Pin for GR3	32	70788	Electrical Circuit Board for GR3	54
42899	Or Tap for GR3	11	70777	Cable Lock for GR3	33	70789	Circuit Board Cover for GR3	55
70756	Piston Spring for GR3	12	42900	Reduction Motor Sensor for GR3	34	70790	Controls for GR3	56
70757	Tap Plug for GR3	13	70778	Electrical Cable for GR3	35	70791	Drip Tray for GR3	57
70758	Lever Tap for GR3	14	70811	Condenser for GR3	36	70792	Drip-Tray Grille in Plastic for GR3	58
70759	Lever Safety Pin (Lower) for GR3	15	70812	P.M. Electric Valve for GR3	37	70817	Front Panel for GR3	59
70760	Lever Safety Pin (Upper) for GR3	16	70805	Valve Coil for GR3	38	70793	Power Switch for GR3	60
70761	Shoulder for GR3	17	70814	Transformer for GR3	39	70818	Rear Panel for GR3	61
70762	Thermostat for GR3	18	70807	Compressor for GR3	40	70794	Side Panel for GR3	62
70763	Return for GR3	19	70779	Charge Valve for GR3	41	61396	Fuse for GR3	
70764	Gear Slide for GR3	20	70780	Feet for GR3	42	46405	Sensor for GR3	
70765	Main Gears for GR3	21	70781	Upper Sprocket for GR3	43	46406	Sensor Cover for GR3	
70766	Evaporator for GR3	22	70782	Threaded Knob for GR3	44	46407	Cable Sensor for GR3	

# Electrical Schematics

**Model DI-IT-0010-S** 39677

**Model DI-IT-0020-S** 39678

**Model DI-IT-0030-S** 39679

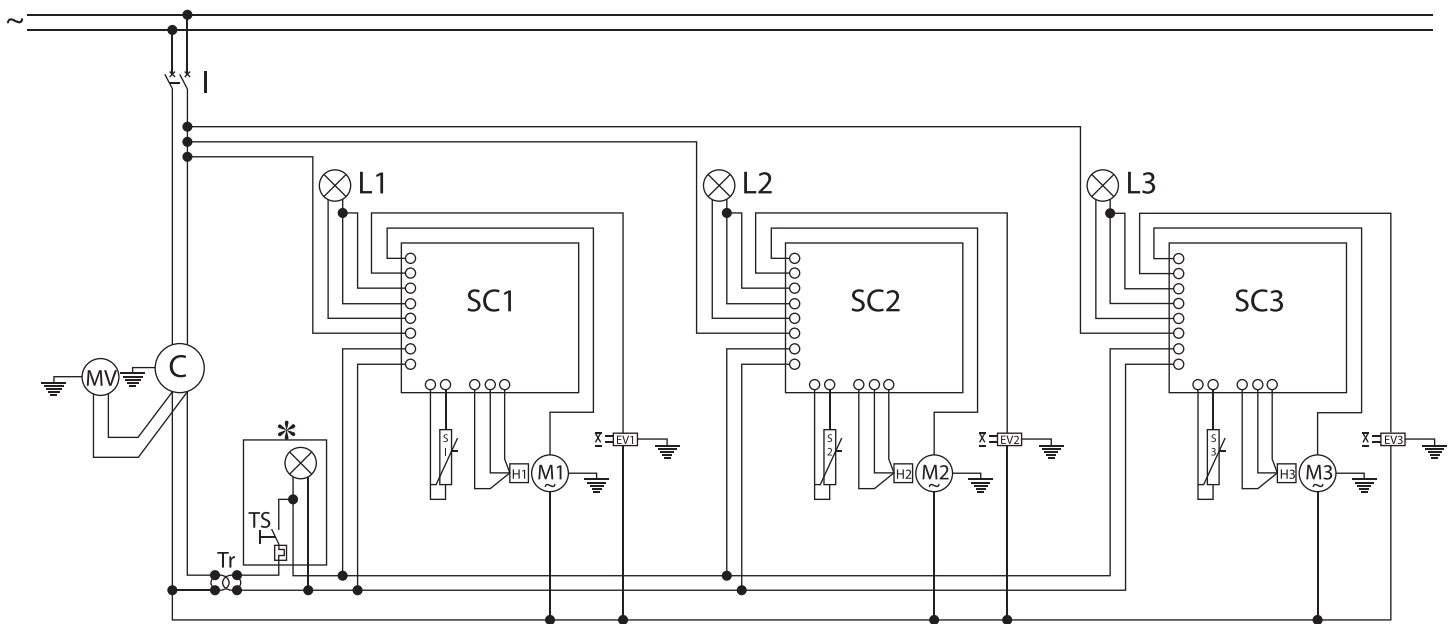

- |    |                    |     |  |     |                           |
|----|--------------------|-----|--|-----|---------------------------|
| I  | =Main Switch       | S1  | } =Drink temperature sensor                                | EV1 | } =Solenoid               |
| C  | =Compressor        | S2  |  | EV2 |                           |
| MV | =Fan               | S3  |  | EV3 |                           |
| TR | =Transformer       | L1  | } =Light   | H1  | } =Reduction motor sensor |
| M1 | } =Reduction Motor | L2  |  | H2  |                           |
| M2 |                    | L3  |  | H3  |                           |
| M3 |                    | SC1 | } =Optional<br>=Refrigeration system<br>temperature sensor |     |                           |
|    | SC2                |     |  |     |                           |
|    | SC3                |     |  |     |                           |
|    |                    | *   |  |     |                           |
|    |                    | TS  |  |     |                           |



# Warranty Registration

Thank you for purchasing an Omcan product. To register your warranty for this product, complete the information below, tear off the card at the perforation and then send to the address specified below. You can also register online by visiting:

Merci d'avoir acheté un produit Omcan. Pour enregistrer votre garantie pour ce produit, complétez les informations ci-dessous, détachez la carte au niveau de la perforation, puis l'envoyer à l'adresse spécifiée ci-dessous. Vous pouvez également vous inscrire en ligne en visitant:

Gracias por comprar un producto Omcan usted. Para registrar su garantía para este producto, complete la información a continuación, cortar la tarjeta en la perforación y luego enviarlo a la dirección indicada a continuación. También puede registrarse en línea en:

<https://omcan.com/warranty-registration/>

For mailing in Canada

Pour postale au Canada

Por correo en Canadá

**OMCAN**

PRODUCT WARRANTY REGISTRATION

3115 Pepper Mill Court,

Mississauga, Ontario

Canada, L5L 4X5

For mailing in the US

Pour diffusion aux États-Unis

Por correo en los EE.UU.

**OMCAN**

PRODUCT WARRANTY REGISTRATION

4450 Witmer Industrial Estates, Unit 4,

Niagara Falls, New York

USA, 14305

*or email to: [service@omcan.com](mailto:service@omcan.com)*



Purchaser's Information

Name: \_\_\_\_\_

Address: \_\_\_\_\_

City: \_\_\_\_\_ Province or State: \_\_\_\_\_ Postal or Zip: \_\_\_\_\_

Country: \_\_\_\_\_

Dealer from which Purchased: \_\_\_\_\_

Dealer City: \_\_\_\_\_ Dealer Province or State: \_\_\_\_\_

Invoice: \_\_\_\_\_

Model Name: \_\_\_\_\_ Model Number: \_\_\_\_\_

Machine Description: \_\_\_\_\_

Date of Purchase (MM/DD/YYYY): \_\_\_\_\_

Would you like to extend the warranty?  Yes  No

Company Name: \_\_\_\_\_

Telephone: \_\_\_\_\_

Email Address: \_\_\_\_\_

Type of Company:

Restaurant  Bakery  Deli

Butcher  Supermarket  Caterer

Institution (specify): \_\_\_\_\_

Other (specify): \_\_\_\_\_

Serial Number: \_\_\_\_\_

Date of Installation (MM/DD/YYYY): \_\_\_\_\_

**Thank you for choosing Omcan | Merci d'avoir choisi Omcan | Gracias por elegir Omcan**



Since 1951 Omcan has grown to become a leading distributor of equipment and supplies to the North American food service industry. Our success over these many years can be attributed to our commitment to strengthen and develop new and existing relationships with our valued customers and manufacturers. Today with partners in North America, Europe, Asia and South America, we continually work to improve and grow the company. We strive to offer customers exceptional value through our qualified local sales and service representatives who provide convenient access to over 5,000 globally sourced products.

---

Depuis 1951 Omcan a grandi pour devenir un des “leaders” de la distribution des équipements et matériel pour l’industrie des services alimentaires en Amérique du Nord. Notre succès au cours de ces nombreuses années peut être attribué à notre engagement à renforcer et à développer de nouvelles et existantes relations avec nos clients et les fabricants de valeur. Aujourd’hui avec des partenaires en Amérique du Nord, Europe, Asie et Amérique du Sud, nous travaillons continuellement à améliorer et développer l’entreprise. Nous nous efforçons d’offrir à nos clients une valeur exceptionnelle grâce à nos ventes locales qualifiées et des représentants de service qui offrent un accès facile à plus de 5000 produits provenant du monde entier.

---

Desde 1951 Omcan ha crecido hasta convertirse en un líder en la distribución de equipos y suministros de alimentos en América del Norte industria de servicios. Nuestro éxito en estos años se puede atribuir a nuestro compromiso de fortalecer y desarrollar nuevas relaciones existentes con nuestros valiosos clientes y fabricantes. Hoy con socios de América del Norte, Europa, Asia y América del Sur, que trabajan continuamente para mejorar y crecer la empresa. Nos esforzamos por ofrecer a nuestros clientes valor excepcional a través de nuestro local de ventas y representantes de los servicios que proporcionan un fácil acceso a más de 5,000 productos con origen a nivel mundial.

