



**Conveyor Oven**  
*Model CE-IT-0500*  
*Item 46725*  
**Instruction Manual**



**STOP**  
**DO NOT RETURN**  
**THIS PRODUCT TO THE STORE**  
For questions or assistance with this product call OMCAN Toll Free: 1 800 465 0234 Customer Service or visit the Support section of [www.omcan.com](http://www.omcan.com)

*Revised - 11/15/2022*



Toll Free: 1-800-465-0234  
Fax: 905-607-0234  
Email: [service@omcan.com](mailto:service@omcan.com)  
[www.omcan.com](http://www.omcan.com)



# ***Table of Contents***

Model CE-IT-0500

---

<b>Section</b>	<b>Page</b>
General Information -----	3 - 4
Safety and Warranty -----	4 - 6
Technical Specifications -----	6
Installation -----	7 - 8
Operation -----	9 - 19
Maintenance -----	19 - 21
Troubleshooting -----	22
Parts Breakdown -----	23 - 31
Electrical Schematics -----	32
Notes -----	33 - 34
Warranty Registration -----	35



# General Information

---

Omcan Manufacturing and Distributing Company Inc., Food Machinery of America, Inc. dba Omcan and Omcan Inc. are not responsible for any harm or injury caused due to any person's improper or negligent use of this equipment. The product shall only be operated by someone over the age of 18, of sound mind, and not under the influence of any drugs or alcohol, who has been trained in the correct operation of this machine, and is wearing authorized, proper safety clothing. Any modification to the machine voids any warranty, and may cause harm to individuals using the machine or in the vicinity of the machine while in operation.

## CHECK PACKAGE UPON ARRIVAL

Upon receipt of [an](#) Omcan shipment please inspect for external damage. If no damage is evident on the external packaging, open carton to ensure all ordered items are within the box, and there is no concealed damage to the machine. If the package has suffered rough handling, bumps or damage (visible or concealed), please note it on the bill of lading before accepting the delivery and contact Omcan within 24 hours, so we may initiate a claim with the carrier. A detailed report on the extent of the damage caused to the machine must be filled out within three days, from the delivery date shown in the shipping documents. Omcan has no recourse for damaged products that were shipped collect or third party.

**Before operating any equipment, always read and familiarize yourself with all operation and safety instructions.**

Omcan would like to thank you for purchasing this machine. It's of the utmost importance to save these instructions for future reference. Also save the original box and packaging for shipping the equipment if servicing or returning of the machine is required.

---

Omcan Fabrication et distribution Compagnie Limitée et Food Machinery d'Amérique, dba Omcan et Omcan Inc. ne sont pas responsables de tout dommage ou blessure causé du fait que toute personne ait utilisé cet équipement de façon irrégulière. Le produit ne doit être exploité que par quelqu'un de plus de 18 ans, sain d'esprit, et pas sous l'influence d'une drogue ou d'alcool, qui a été formé pour utiliser cette machine correctement, et est vêtu de vêtements de sécurité appropriés. Toute modification de la machine annule toute garantie, et peut causer un préjudice à des personnes utilisant la machine ou des personnes à proximité de la machine pendant son fonctionnement.

## VÉRIFIEZ LE COLIS DÈS RÉCEPTION

Dès réception d'une expédition d'Omcan veuillez inspecter pour dommages externes. Si aucun dommage n'est visible sur l'emballage externe, ouvrez le carton afin de s'assurer que tous les éléments commandés sont dans la boîte, et il n'y a aucun dommage dissimulé à la machine. Si le colis n'a subi aucune mauvaises manipulations, de bosses ou de dommages (visible ou cachée), notez-le sur le bond de livraison avant d'accepter la livraison et contactez Omcan dans les 24 heures qui suivent, pour que nous puissions engager une réclamation auprès du transporteur. Un rapport détaillé sur l'étendue des dommages causés à la machine doit être rempli dans un délai de trois jours, à compter de la date de livraison indiquée dans les documents d'expédition. Omcan n'a aucun droit de recours pour les produits endommagés qui ont été expédiés ou cueilli par un tiers transporteur.

# General Information

---

Avant d'utiliser n'importe quel équipement, toujours lire et vous familiariser avec toutes les opérations et les consignes de sécurité.

Omcan voudrais vous remercier d'avoir choisi cette machine. Il est primordial de conserver ces instructions pour une référence ultérieure. Également conservez la boîte originale et l'emballage pour l'expédition de l'équipement si l'entretien ou le retour de la machine est nécessaire.

-----  
Omcan Empresa De Fabricacion Y Distribucion Inc. Y Maquinaria De Alimentos De America, Inc. dba Omcan y Omcan Inc. no son responsables de ningun daño o perjuicio causado por cualquier persona inadecuada o el uso descuidado de este equipo. El producto solo podra ser operado por una persona mayor de 18 años, en su sano juicio y no bajo alguna influencia de droga o alcohol, y que este ha sido entrenado en el correcto funcionamiento de esta máquina, y ésta usando ropa apropiada y autorizada. Cualquier modificación a la máquina **anúla** la garantía y puede causar daños a las personas usando la máquina mientras esta en el funcionamiento.

## REVISE EL PAQUETE A SU LLEGADA

Tras la recepcion de un envio Omcan favor inspeccionar daños externos. Si no hay daños evidentes en el empaque exterior, Habra el carton para asegurarse que todos los articulos solicitados estén dentro de la caja y no encuentre daños ocultos en la máquina. Si el paquete ha sufrido un manejo de poco cuidado, golpes o daños (visible o oculto) por favor anote en la factura antes de aceptar la entrega y contacte Omcan dentro de las 24 horas, de modo que podamos iniciar una reclamación con la compañía. Un informe detallado sobre los daños causados a la máquina debe ser llenado en el plazo de tres días, desde la fecha de entrega que se muestra en los documentos de envío. Omcan no tiene ningun recurso por productos dañados que se enviaron a recoger por terceros.

**Antes de utilizar cualquier equipo, siempre lea y familiarizarse con todas las instrucciones de funcionamiento y seguridad.**

Omcan le gustaría darle las gracias por la compra de esta máquina. Es de la mayor importancia para salvar estas instrucciones para futuras consultas. Además, guarda la caja original y el embalaje para el envío del equipo si servicio técnico o devolución de la máquina que se requiere.

# Safety and Warranty

---

## WARNINGS FOR THE INSTALLER

Verify that the electrical connections for the oven comply with local, national and European regulations.

- Comply with the instructions provided in this Manual.
- Do not make haphazard electrical connections with temporary or uninsulated cables.
- Check that the grounding connection to the power system is efficient.
- Always use individual safety devices and other means of protection required by the law.

# Safety and Warranty

---

**Note:** Installing a hood for ventilation is not required with adequate ventilation in the kitchen.

## WARNINGS FOR THE USER

The environmental conditions of the location where the oven is installed must have the following characteristics:

- Be dry.
- Away from water sources and heat.
- With adequate ventilation and lighting and compliant with the hygiene and safety standards required by current laws.
- The floor must be flat and compact to facilitate thorough cleaning.
- No obstacles of any kind should be placed in the immediate vicinity of the oven, which could affect its proper.
- Make sure that children do not approach the oven when it is operating.
- Comply with the instructions provided in this Manual.
- Do not remove or tamper with the oven safety devices.
- Always pay utmost attention, i.e., to what you are doing and do not use the oven when you are distracted.
- Comply with the instructions and warnings on the oven plates.  
The plates are safety devices; therefore, they must always be perfectly legible. If they are damaged and illegible, they must be replaced, once they have been requested from the Manufacturer.
- Disconnect the power supply at the end of each use and before cleaning and maintenance operations.

## WARNINGS FOR THE MAINTENANCE TECHNICIAN

Comply with the instructions provided in this Manual:

- Always use individual safety devices and other suitable means of protection.
- Before starting any maintenance operation, make sure that the oven has cooled down.
- If even one of the safety devices is turned off or not working, the oven should be considered non-functional.
- Disconnect the power supply before working on electrical and electronic parts and connectors.

**RESIDENTIAL USERS: Vendor assumes no liability for parts or labor coverage for component failure or other damages resulting from installation in non-commercial or residential applications. The right is reserved to deny shipment for residential usage; if this occurs, you will be notified as soon as possible.**

## 1 YEAR PARTS AND LABOUR WARRANTY

Within the warranty period, contact Omcan Inc. at 1-800-465-0234 to schedule [an](#) Omcan authorized service technician to repair the equipment locally.

Unauthorized maintenance will void the warranty. Warranty covers electrical and part failures, not improper use.

# Safety and Warranty

---

Please see <https://omcan.com/disclaimer> for complete info.

## WARNING:

The packaging components are classified as normal solid urban waste and can therefore be disposed of without difficulty.

In any case, for suitable recycling, we suggest disposing of the products separately (differentiated waste) according to the current norms.

**DO NOT DISCARD ANY PACKAGING MATERIALS IN THE ENVIRONMENT!**

# Technical Specifications

---

<b>Model</b>	<b>CE-IT-0500</b>
<b>Electrical</b>	230V / 60Hz / 3
<b>Max. Power Absorption</b>	14.2 kW
<b>Max Temp. for Top &amp; Bottom</b>	350°C / 662°F
<b>Max. Operating Ambient Temp.</b>	0 - 40°C / 32 - 104°F
<b>Max. Humidity</b>	95%
<b>Conveyor Dimensions</b>	19.7" x 63" / 500 x 1600mm
<b>Chamber Dimensions</b>	29.5" x 19.7" x 3.7" / 749 x 500 x 94mm
<b>Weight</b>	With Support: 427.7 lbs. / 194 kgs.
	Without Support: 361.6 lbs. / 164 kgs.
<b>Machine Dimensions</b>	46.7" x 70.1" x 19.7" / 1186 x 1781 x 500mm
<b>Support Dimensions</b>	33.9" x 41.3" x 21.9" / 861 x 1049 x 556mm
<b>Stand Weight</b>	66.1 lbs. / 30 kgs.
<b>Stand Packaging Weight</b>	72.8 lbs. / 33 kgs.
<b>Machine Packaging Dimensions</b>	80.7" x 57.1" x 29.9" / 2050 x 1450 x 760mm
<b>Stand Packaging Dimensions</b>	42.9" x 33.9" x 21.9" / 1090 x 860 x 555mm
<b>Item Number</b>	46725

**TO BE INSTALLED BY A CERTIFIED ELECTRICIAN.**

## OVEN UNLOADING AND HANDLING

The oven must be unloaded and handled by a qualified forklift operator.

## OVEN POSITIONING AND OVERLAPPING

Remove the conveyor belt.

Use a forklift truck with adequate capacity.

Raise the caps and insert the forks, suitably covered with soft material to prevent damage, in the cooking chamber, through the inlet or the tunnel exit (Fig.1).

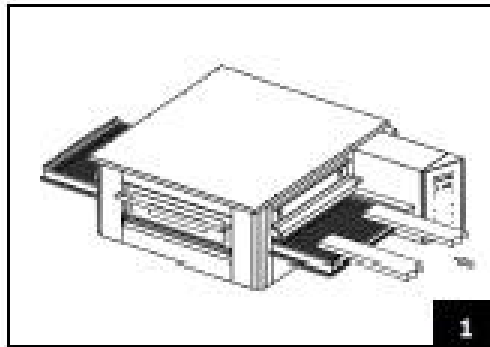

Position the oven at the corners of the base (Fig.2).

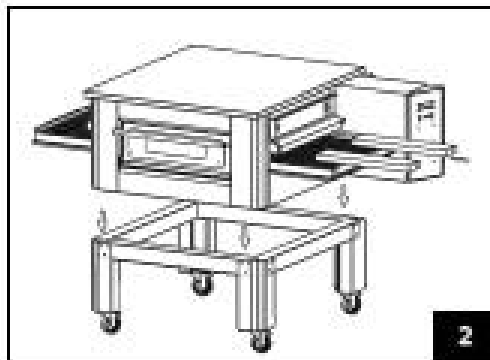

# Installation

---

## MAXIMUM NUMBER OF OVERLAYABLE OVENS: 3

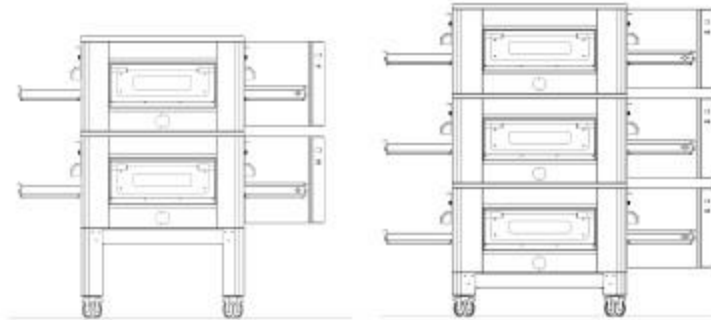

Remove any polystyrene protections and remove the protective film, avoiding the use of tools that can damage the surfaces.

## CONNECTION TO UTILITIES (ELECTRICAL CONNECTION)

The oven is supplied with a power cord without a plug. Connection to the electric network must be performed by interposing a differential magneto-thermal switch with suitable characteristics, in which the minimum opening distance between the contacts is at least 3 mm.

### IN ADDITION, FOLLOW THESE INSTRUCTIONS:

- The mains socket must be easily accessible and must not require any oven handling.
- The electrical connection must be easily accessible even after oven installation.
- The distance between the oven and the socket must be such that it does not cause the power cord to stretch. Furthermore, the cable itself must not be under the base of the oven.
- In order to avoid risks, any damaged power cord must be replaced by technical assistance service or a qualified technician.

## GROUNDING

**The system MUST be grounded.**

In compliance with current regulations, it is mandatory to connect the equipment to an equipotential system whose efficiency must be correctly checked according to the regulations in force. The connection is made on the special terminal located at the back of the oven, with a cable with a minimum section of 10mm<sup>2</sup>.

## CONTROL PANEL

1. Off button.
2. Date and time display.
3. Top setpoint.
4. Top temperature.
5. Bottom setpoint.
6. Bottom temperature.
7. Conveyor commands.
8. INCREASE and DECREASE keys.
9. Program key.
10. Menu key.
11. Logo button to access Technical Data.
12. Selected cooking program.

## SWITCH ON DISPLAY

To turn the display on, press the On button in the middle of the display for 3 seconds, the main screen appears.

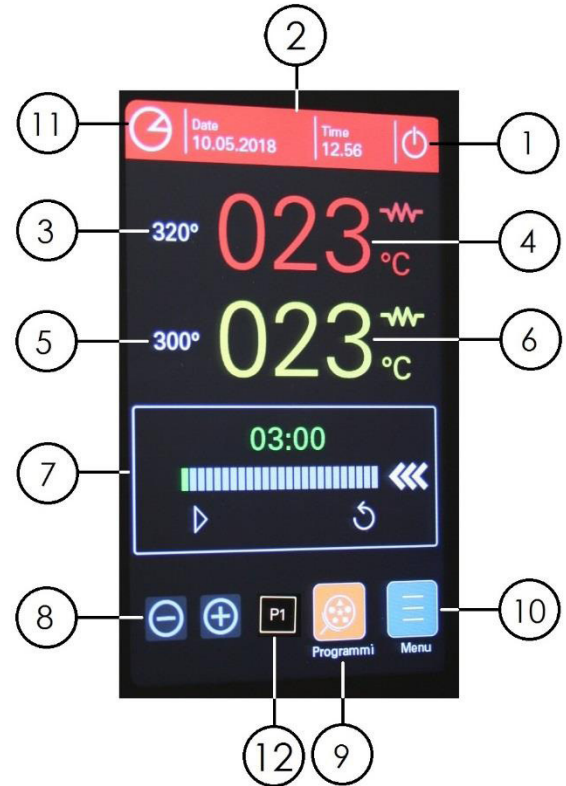
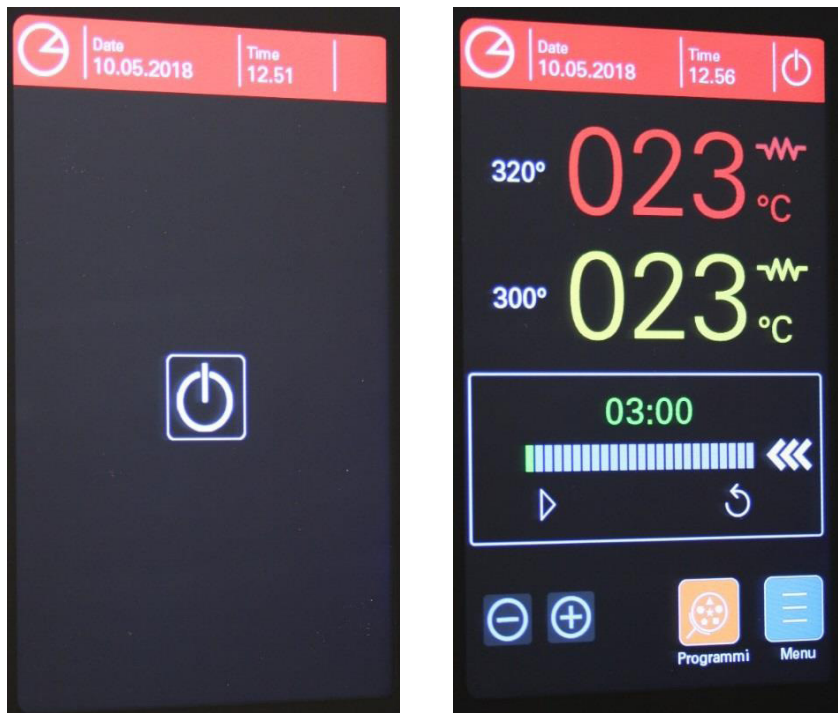

# Operation

## SELECT LANGUAGE



- Press the menu button.
- Press the LCD Settings button.
- Select the language.
- Save.
- Exit.

## DATE AND TIME SETTING

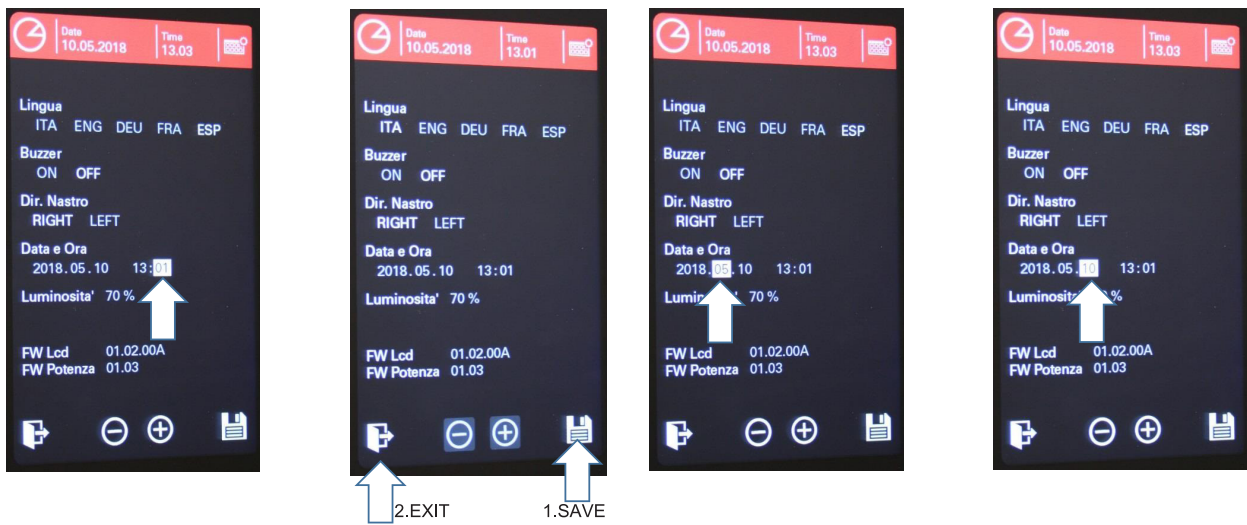
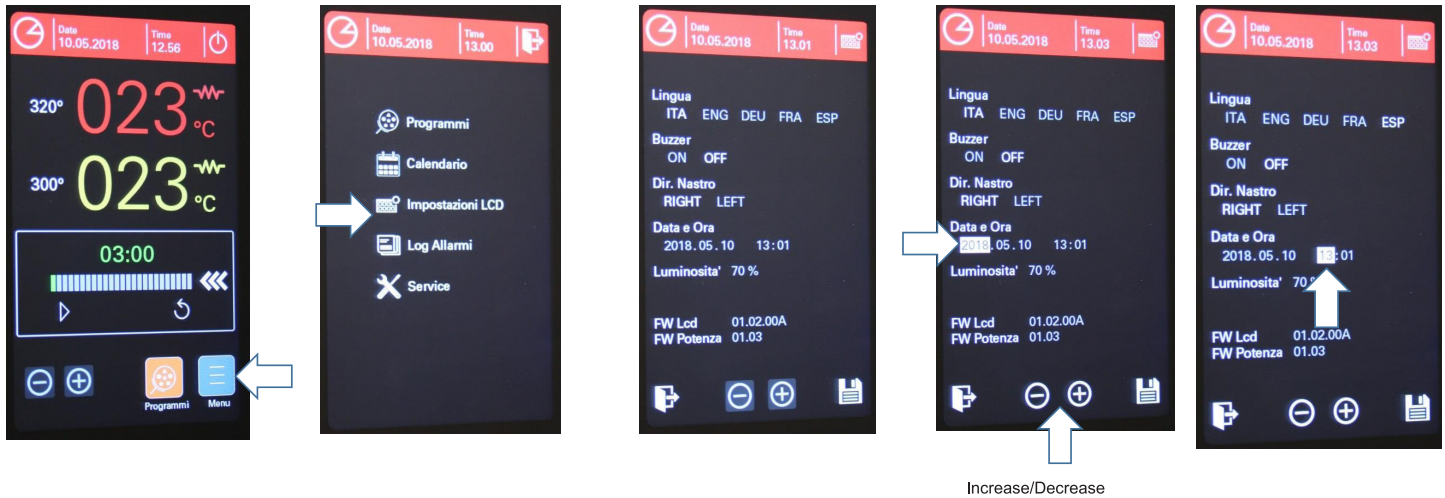

- Press the Menu button.
- Press the LCD settings button.
- Year setting.
- Month setting.
- Day setting.
- Time setting.
- Minute setting.
- Data saving.

## WORK SETPOINT SETTINGS

The procedures for setting the top and bottom temperature are described below.

# Operation

## TOP SETPOINT



- Press on the Top setpoint to change the set value.
- Increase or decrease with “+” and “-”.
- Confirm data.

## BOTTOM SETPOINT



- Press on the Bottom setpoint to change the set value.
- Increase or decrease with “+” and “-”.
- Confirm data.

## COOKING TIME SETTINGS

The procedures for setting the cooking time are described below.



Increase/Decrease

- Press the conveyor timer.
- Confirm by pressing the timer again.
- Start conveyor motion.
- Stop conveyor movement.
- Conveyor motion reversal.
- Reversed motion.

# Operation

## COOKING PROGRAM SETTINGS

You can set up to ten different cooking programs, by using the top, bottom and cooking time according to your recipes and needs. Proceed as follows to set the cooking programs.

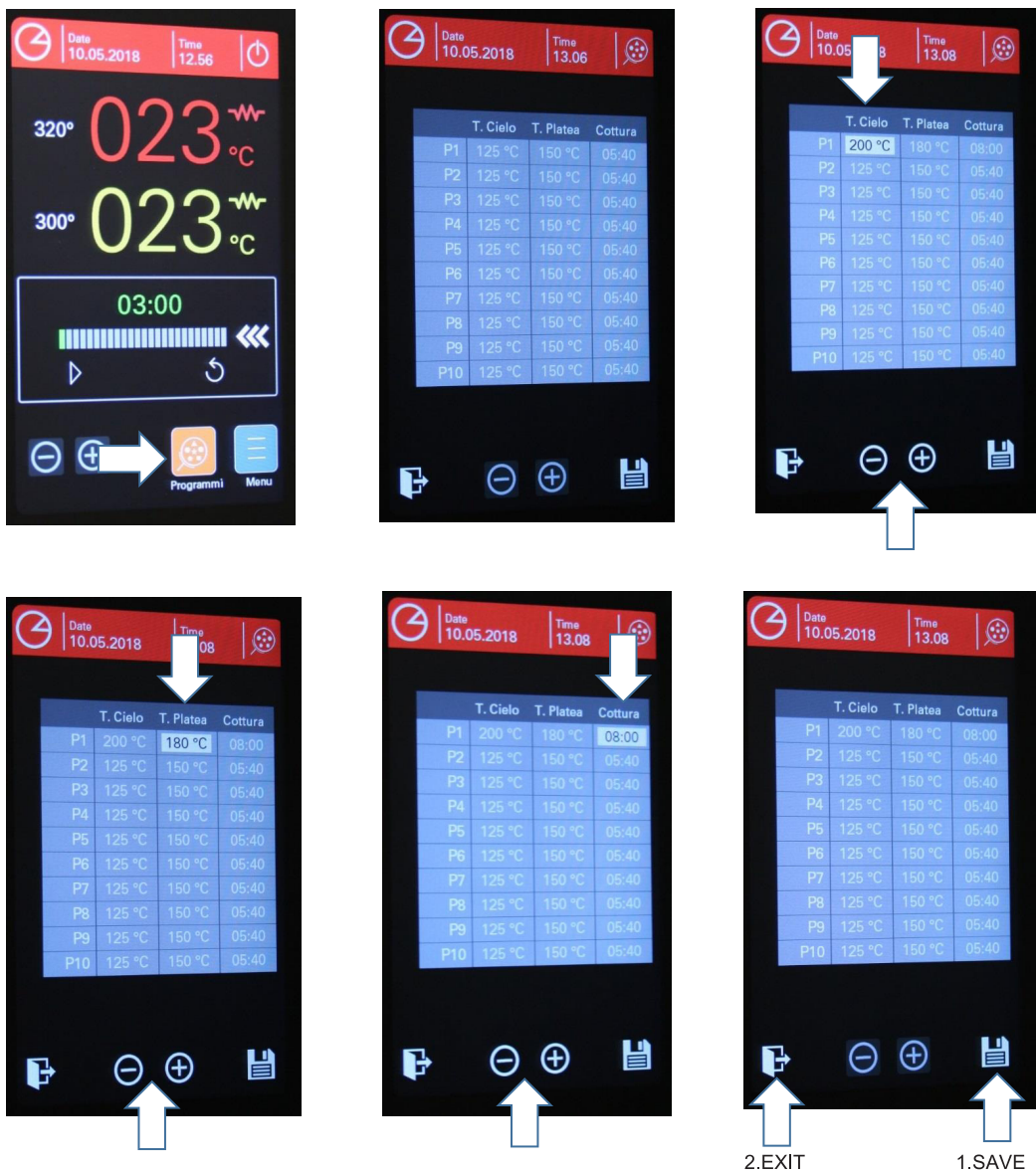

- Press the icon Programs.
- Program Page.
- Top temperature setting.
- Bottom temperature setting.
- Cooking time setting.
- Data saving.

2.EXIT

1.SAVE

## SET FUNCTION POWER ON/OFF

“Set function power on/off” allows you to set the oven on/off program and simultaneously start a different program. Power on and off can be managed: Manual, Daily and Weekly. To access the programming of this function proceed as follows.

### MANUAL SWITCH ON/OFF

This function disables any automatic power on or off.

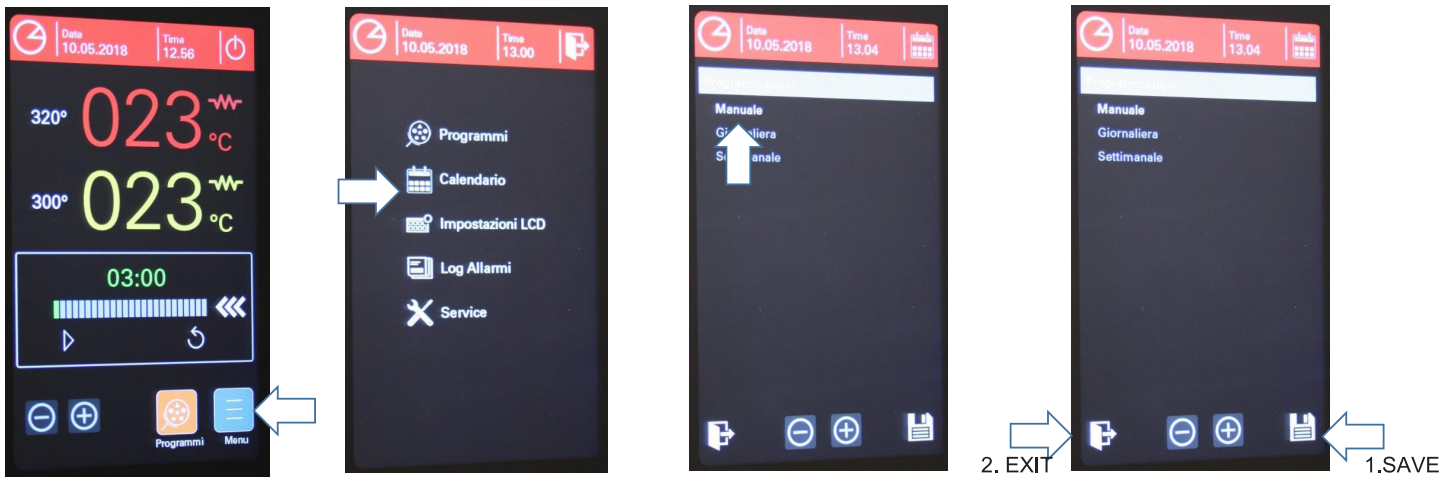

- Press the Menu button.
- Press the Calendar button.
- Select Manual.
- Save data.

# Operation

## DAILY SWITCH ON/OFF

This function automatically switches the oven on and/or off by setting the desired Start and Stop times.



- Press the Menu button.
- Press the Calendar button.
- Select Daily.
- Set hours and minutes.
- Set the flag to Start and Stop.
- Save data.

## WEEKLY SWITCH ON/OFF

This function automatically switches the oven on and off by following a weekly calendar on days and times set according to your production needs.



- Press the Menu button.
- Press the Calendar button.
- Select Weekly.
- Set the desired time on the day in which you want the oven to switch on and/or off automatically.
- Always remember to put the flag to select Start (on) and/or Stop (off).
- Save data.

# Operation

## METHOD OF USE

### FUNCTIONAL VERIFICATION

Before switching the oven on, make sure that:

- You have removed the protective film, where present.
- You have correctly inserted the plug into the power supply socket.
- That supply voltage, frequency and system power are compatible with the values shown on the plate on the right side of the oven.

### OVEN POWER ON

Proceed as follows to switch the oven on:

- Connect the power plug to the socket.
- Once the display is on, press the On/Off button for 3 seconds.
- Set the desired bottom temperature.
- Set the desired top temperature.
- Set the conveyor crossing time.

### INITIAL OVEN POWER ON

When using the appliance for the first time, it is advisable to perform a burn-in process to eliminate unpleasant odours caused by the evaporation of moisture contained in the insulating material and internal metal parts.

Follow the steps below:

- Set the top and bottom at 150°C.
- Activate the conveyor.
- Leave the oven in operation for 8 hours.

### GENERAL COOKING INSTRUCTIONS

Product	Temperature	Time	Additional Equipment
Pizza by the slice (precooking).	250°C / 482°F	5 min.	Baking Sheet
Pizza by the slice (final cooking).		3 min.	
Small puff pastry pizza.	200°C / 392°F	15 min.	
Milk bread nuggets.	170°C / 338°F	14 min.	
Chicken breast.	190°C / 374°F	15 min.	
Baked sea bass.	220°C / 428°F		
Frozen croissant (defrosted for 2 hours).	150°C / 302°F	11 min.	
Apple strudel.	200°C / 392°F	18 min.	
Baguettes (precooked vacuum-packed).	180°C / 356°F	7 min.	Perforated pan
Italian-type round pizza.	320°C / 608°F	3 min. 30 sec. - 4 min. 30 sec.	Mesh
American-type round pizza.	275°C / 527°F	6 min.	

# Operation

Bruschetta.	270°C / 518°F	2 min. 30 sec.	On conveyer
Taralli.	280°C / 536°F	4 min. 20 sec.	
Lasagna pie.	170°C / 338°F	20 min.	
Cheeseburger.	190°C / 374°F	15 min.	
Grilled aubergines.	320°C / 608°F	6 min. 30 sec.	
Grilled peppers.			
Grilled courgettes.			
Oven-baked potatoes.	170°C / 338°F	30 min.	Aluminium pan
Tortillas with peppers.	200°C / 392°F	20 min.	
Roast beef.	190°C / 374°F	15 min.	
Meatballs with tomato sauce.		12 min.	
Oven-baked peppers.	170°C / 338°F	13 min.	
Grilled tomatoes.		12 min.	
Apple tartlets.	190°C / 374°F	16 min.	
Paella (final cooking).	290°C / 554°F	12 min. - 15 min.	Paella pan

## COOL DOWN

When switched off, the oven will keep the ventilation switched on until it is cooled down. The oven will continue to cool down to a temperature of 140°C, after which it will automatically shut off as soon as such temperature is reached.

# Maintenance

## MAINTENANCE AND CLEANING

### SAFETY PRECAUTIONS

Before carrying out any maintenance operation, take the following safety precautions:

- Make sure that the oven is switched off and completely cooled.
- Make sure that the oven is not electrically powered.
- Make sure that the power supply can not be reactivated accidentally; unplug the power cord.
- Use the personal protective equipment required by Directive 89/391/EEC.
- Do not use water through pipes or high pressure washers.
- Do not use abrasive materials or sponges to clean the door glasses and the metal parts of the oven.
- Do not clean the glass door when it is hot.
- Install all protections and reactivate all safety devices once the maintenance or repair operations have been completed, and prior to putting the oven back into service.

# Maintenance

## ROUTINE MAINTENANCE TO BE PERFORMED BY THE USER

Before carrying out any maintenance operation, disconnect the power supply and follow the “Safety precautions”. In order to keep the oven always clean and efficient, regular cleaning and maintenance must be carried out at regular intervals as follows:

### DAILY CLEANING

Clean the external parts of the oven such as doors, door handles and the front panel with a soft cloth and a mild detergent. Do not use abrasive sponges.

### MONTHLY CLEANING

1. Lubricate the conveyor belt bearings, if necessary.
2. Clean the cooking chamber (after removing the conveyor belt).
3. Cleaning the cooling fan filters.

### YEARLY CLEANING

1. Using a vacuum cleaner, clean the inside of the cooking chamber, after removing the conveyor belt.
2. Clean all the ventilation outlets on the front, side and back of the oven.
3. Remove the control panel, using a vacuum cleaner, thoroughly vacuum the compartment, taking care not to damage the components and the electrical wiring.

## BELT DISASSEMBLY AND RE-ASSEMBLY

Once the “Safety precautions” have been carried out, proceed as follows:

### BELT DISASSEMBLY INSTRUCTIONS

To reassemble it, proceed in the opposite direction.

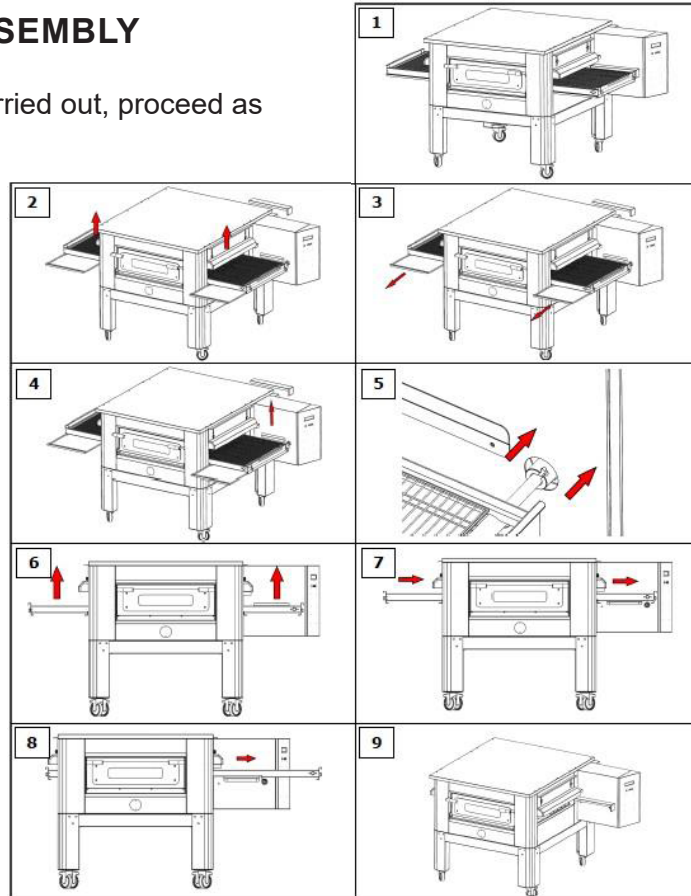

# Maintenance

## MESH PULL

Once the “Safety precautions” have been carried out, proceed as follows:

**To tighten the mesh, twist the nuts clockwise; twist them counterclockwise to relax it.**

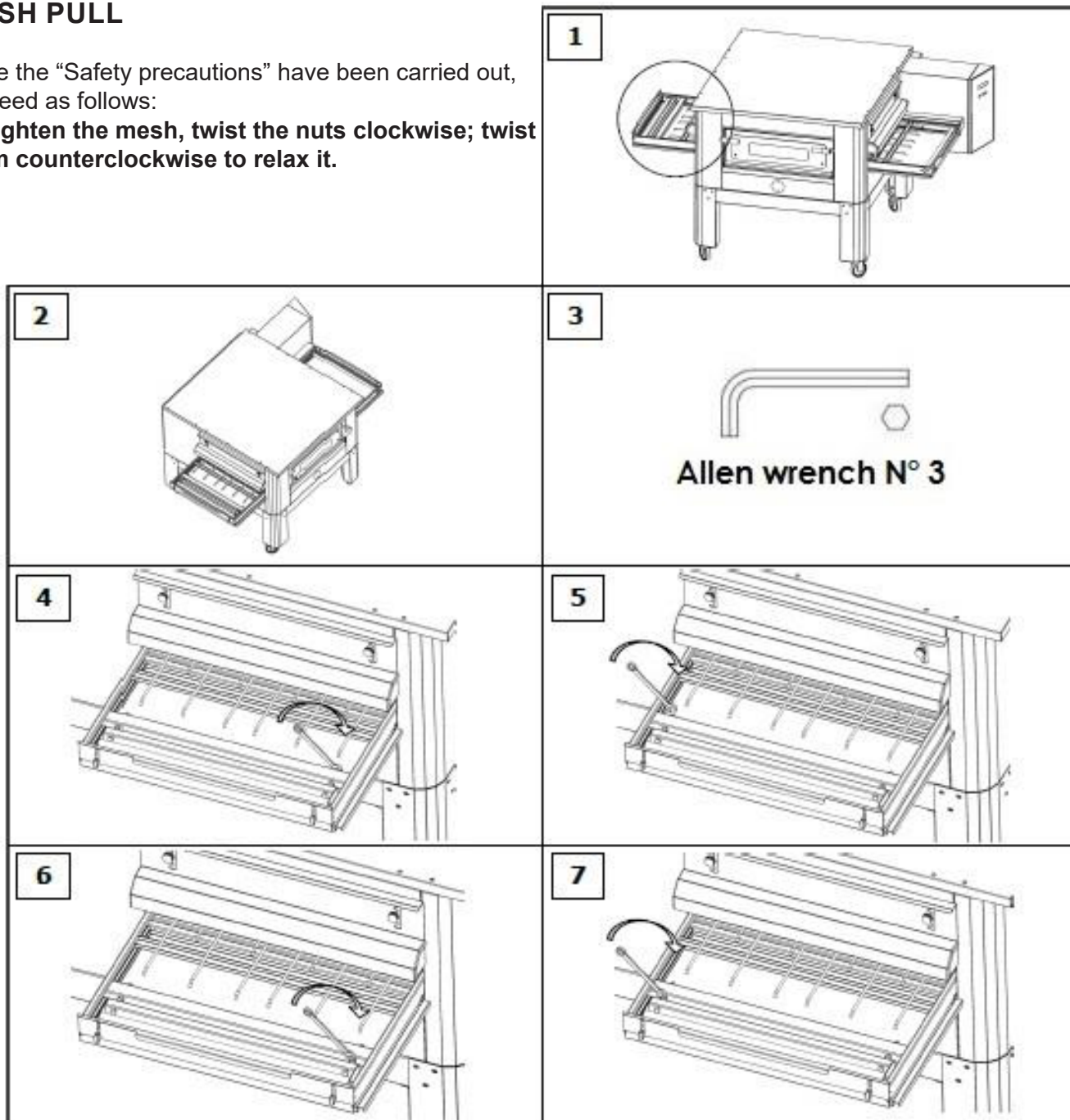

## SPECIAL MAINTENANCE TO BE PERFORMED BY SPECIALIZED TECHNICIANS

For any operation that is not the responsibility of the user, it is necessary to request the intervention of a specialized technician. Contact your local dealer and/or service representative. Before carrying out any maintenance operation, disconnect the power supply and follow the “Safety precautions”.

# Troubleshooting

<b>Problem</b>	<b>Possible Cause</b>	<b>Solution</b>
The oven does not switch on, the display is off.	Lack of electricity.	Check socket, plug and power cable, and internal terminal board in the control compartment.
	Possible activation of the safety thermostat.	Open the electrical system compartment panel and reset the safety thermostat.
The cooking chamber does not heat up properly.	Top and/or bottom have been set too low.	Increase the percentage of top and/or bottom.
	Resistors are partially functional.	Check voltage on resistors.
		Check if resistors are faulty.
One or more relays are faulty.	Replace one or more relays.	
<b>Alarm Code</b>	<b>Cause</b>	<b>Solution</b>
999	Probe broken or disconnected.	Connect or replace probe.

# Parts Breakdown

Model CE-IT-0500 46725

General Assembly

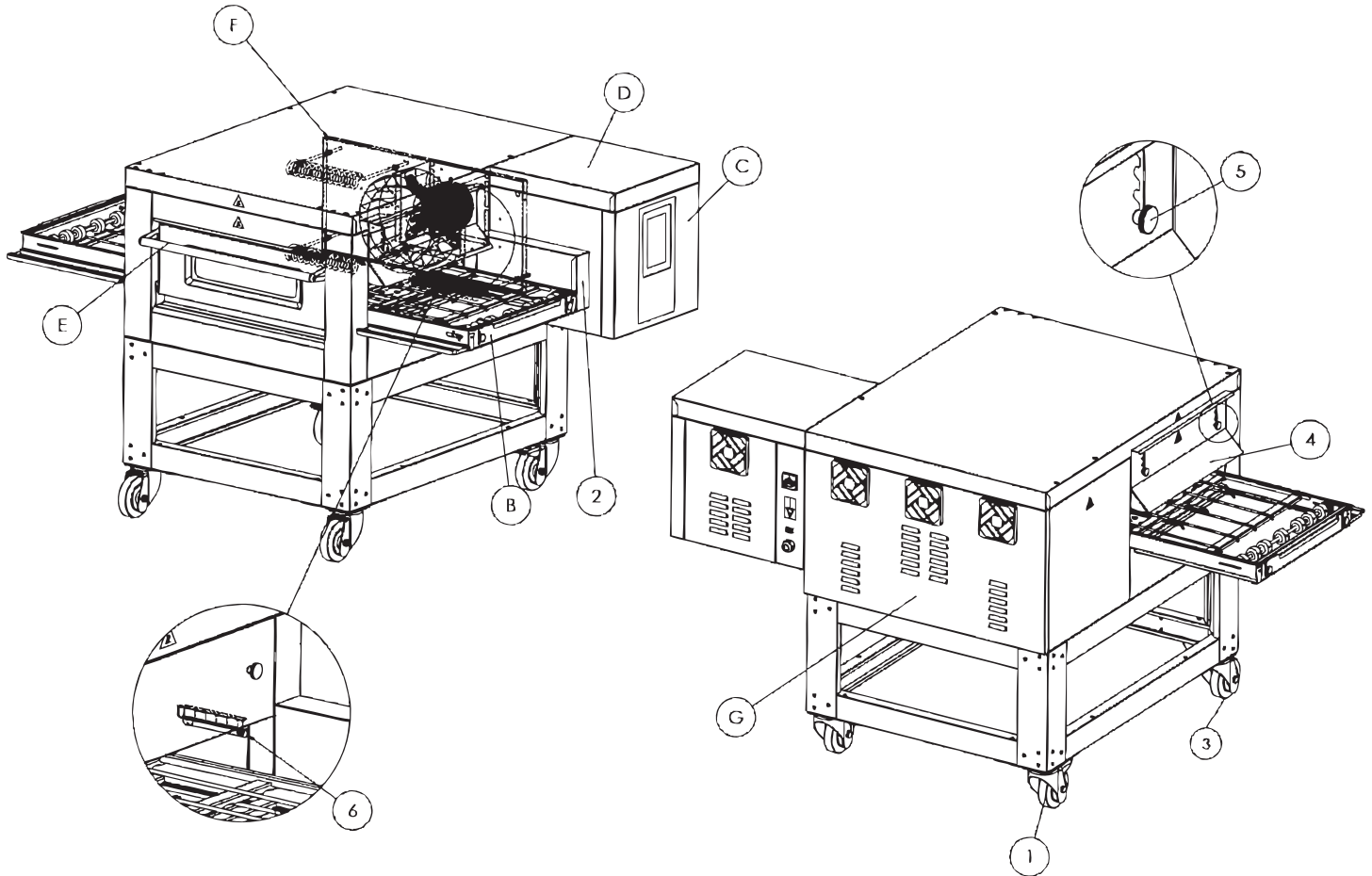



# Parts Breakdown

Model CE-IT-0500 46725

Control Panel

C

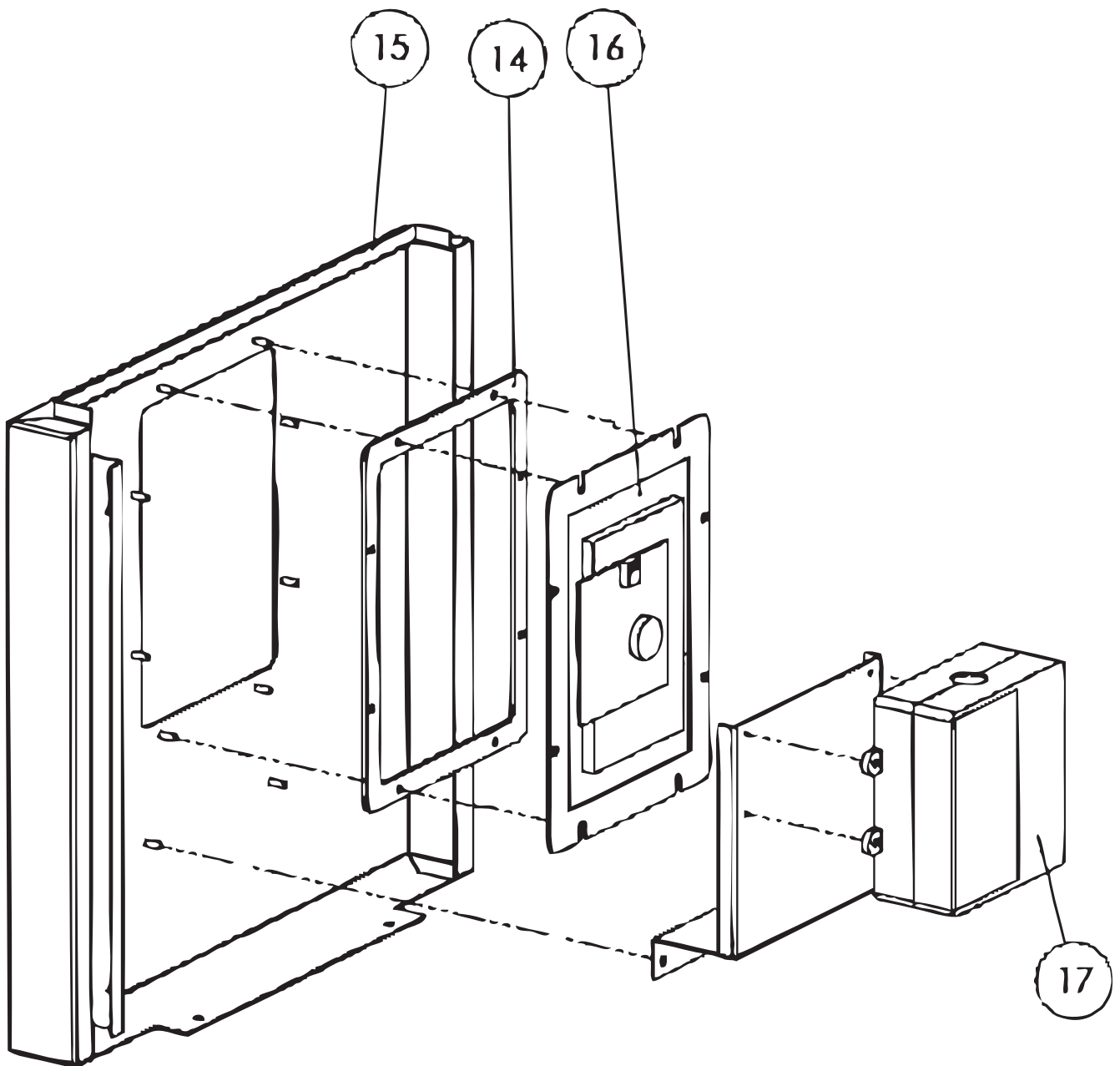

# Parts Breakdown

Model CE-IT-0500 46725

Electrical Components

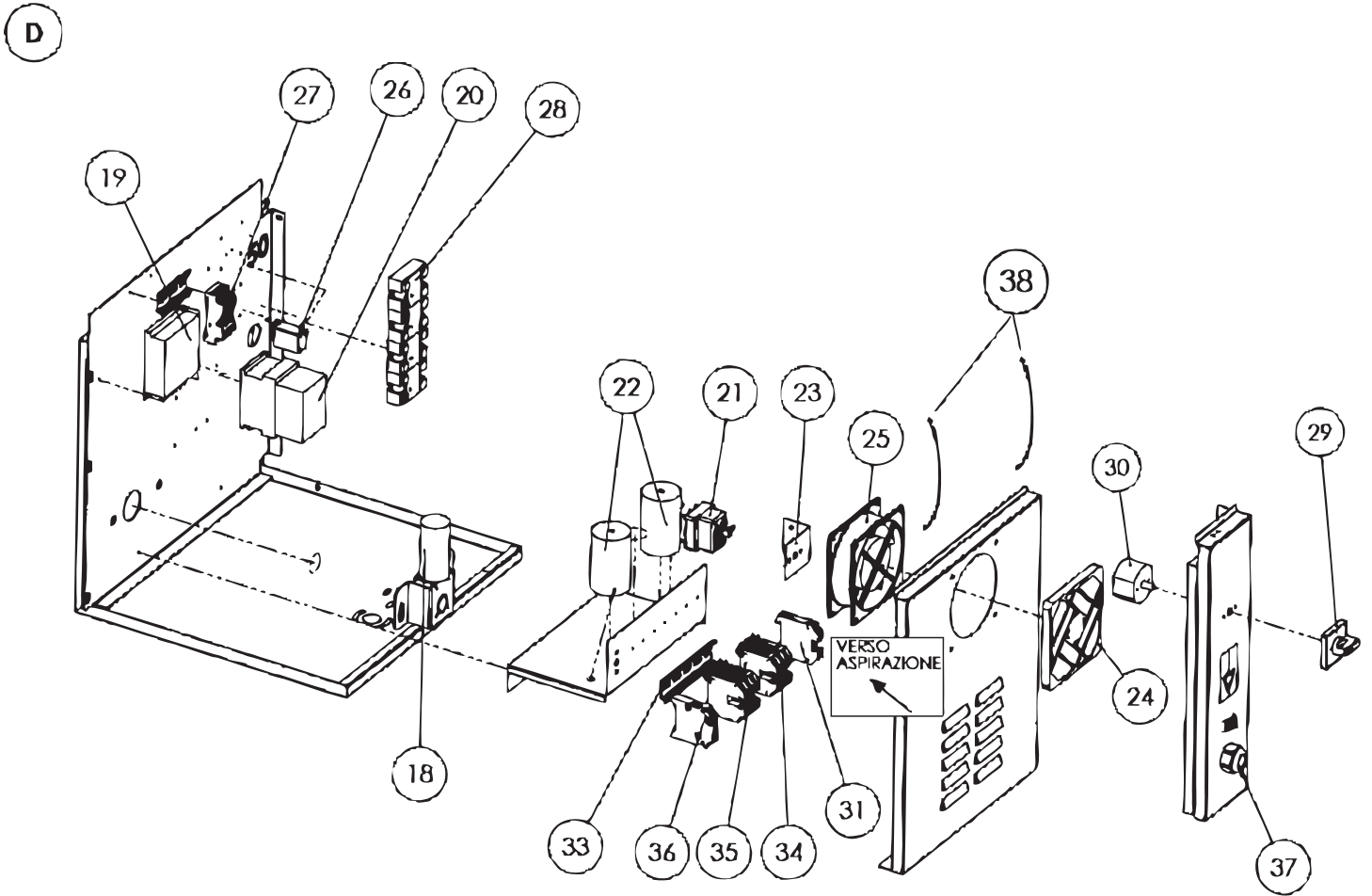

# Parts Breakdown

Model CE-IT-0500 46725

Door Assembly

E

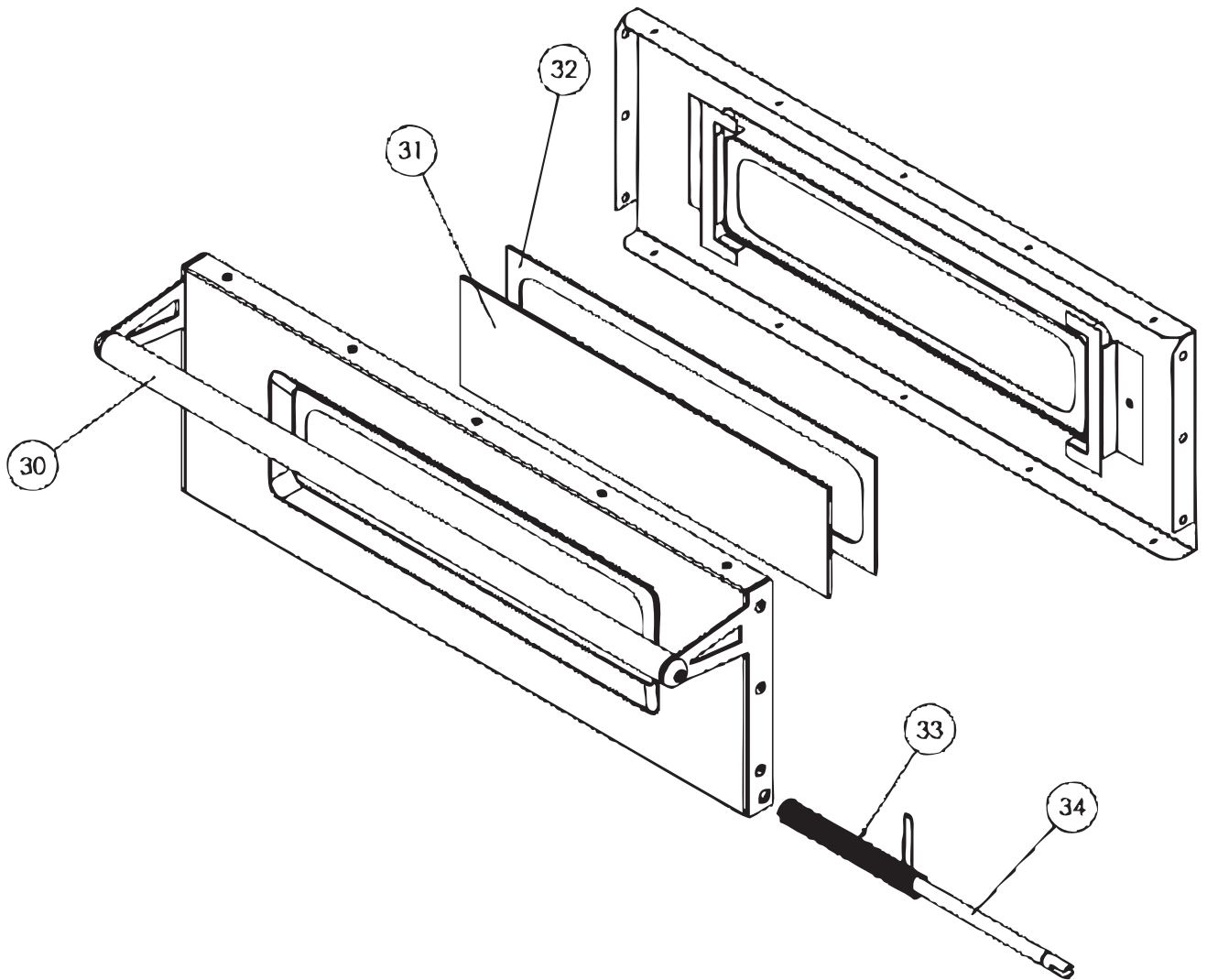

# Parts Breakdown

Model CE-IT-0500 46725

Ventilation

F

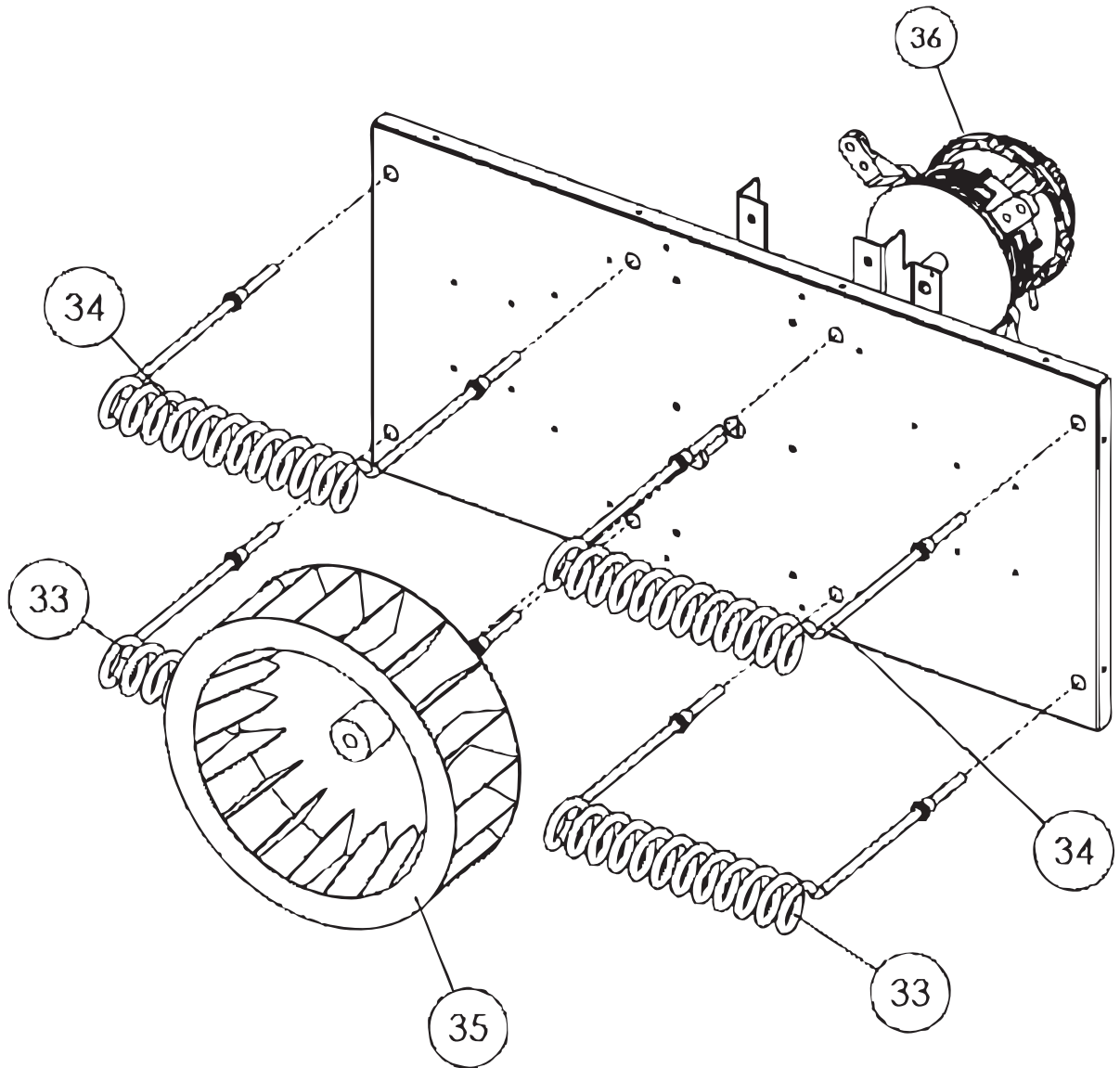

# Parts Breakdown

Model CE-IT-0500 46725

Back Panel

**G**

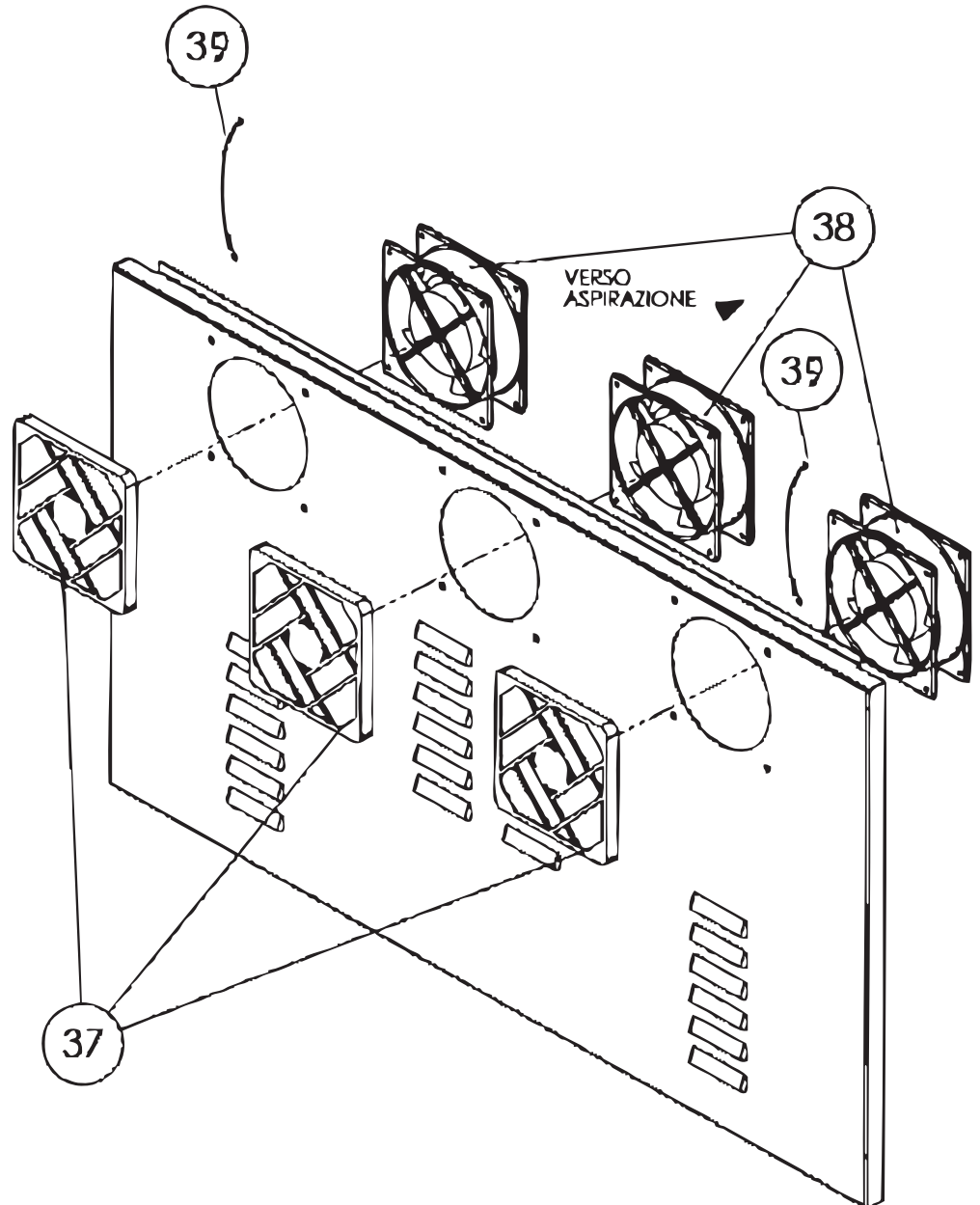

# Parts Breakdown

**Model CE-IT-0500** 46725

**General Assembly**

Item No.	Description	Position	Item No.	Description	Position	Item No.	Description	Position
AL738	Wheel without Brake for 46725	1	AL740	Wheel with Brake for 46725	3	AH466	Knob Din 464-M6x16 for 46725	5
AL739	Crancase Motor for 46725	2	AL741	Removable End Plug for 46725	4	AL742	Thermostat Bracket for 46725	6

## Conveyor

Item No.	Description	Position	Item No.	Description	Position	Item No.	Description	Position
AH470	Right-Left Tape Closure for 46725	7	AH475	Conveyor Transmission for 46725	14	AL750	Bush Stops Rod for 46725	23
AH472	Right Tray for 46725	8	AH476	Motorgear Transmission for 46725	15	AL751	Right Tensioner Plate for 46725	24
AH471	Left Tray for 46725	9	AH469	Bush I10xE14x14 for 46725	17	AL752	Left Tensioner Plate for 46725	25
AH466	Knob Din 464-M6x16 for 46725	10	AL746	Rotation Rod for 46725	18	AH467	Stainless Steel Conveyor Belt for 46725	28
AL743	Roller for 46725	11	AL747	Traction Rod for 46725	19	AL753	Conveyor Belt for 46725	29
AL744	Needle Roller for 46725	12	AL748	Conveyor Tensioner for 46725	20	AK377	Complete 50 Tunnel Tape Assembly for 46725	
AL745	Cogwheel for 46725	13	AL749	Bronze Bushing Base for 46725	22			

## Control Panel

Item No.	Description	Position	Item No.	Description	Position
AL754	Display Gasket for 46725	14	AH478	LCD 7" Touchscreen Display for 46725	16
AL755	Controls Panel for 46725	15	AH479	Control Power Board for 46725	17

## Electrical Components

Item No.	Description	Position	Item No.	Description	Position	Item No.	Description	Position
AH481	Transformer 220V/24VDC 35W for 46725	18	AH488	Relay 24V for 46725	26	AL762	Beige Clamp for 46725	35
AH480	Tape Motorgear for 46725	19	AH489	Relay Holder for 46725	27	AL763	Cover Clamp for 46725	36
AL756	Contactora for 46725	20	AH490	SSR Relay for 46725	28	AL764	Cable Gland for 46725	37
AL757	Safety Thermostat for 46725	21	74760	Actuator 48x48 Grey/Black Int.Mask 32A for 46725	29	AL765	Lock Nut for 46725	37
AH485	Threephases Filter EMC for 46725	22	42035	16A Actuator P0160004R001 4-Polar Switch for 46725	30	AL766	Cord for Panels for 46725	38
AL742	Thermostat Bracket for 46725	23	AL759	Green-Yellow Clamp for 46725	31	AL767	Electrical System for 46725	
AL758	Protection Fan for 46725	24	AL760	Bar L=120mm for 46725	33			
AH487	Fan 230V 50/60Hz 120x120 for 46725	25	AL761	Blue Clamp for 46725	34			

# Parts Breakdown

**Model CE-IT-0500** 46725

## Door Assembly

Item No.	Description	Position	Item No.	Description	Position	Item No.	Description	Position
AL768	Handle Ensemble for 46725	30	76609	Joint Entry for 46725	32	AL769	Pin for Spring for 46725	34
41771	Glass Door for 46725	31	43659	Door Spring for 46725	33	AL770	Door Ensemble for 46725	

## Ventilation

Item No.	Description	Position	Item No.	Description	Position	Item No.	Description	Position
AH493	Heating Element 230V 2800W for 46725	33	AH495	Radial Fan (VRD 0300-100BD20P) 300 for 46725	35	AL771	Ventilation Ensemble for 46725	
AH494	Heating Element 230V 4100W for 46725	34	AH496	Motor Fan for 46725	36			

## Back Panel

Item No.	Description	Position	Item No.	Description	Position	Item No.	Description	Position
AL758	Protection Fan for 46725	37	AH487	Fan 230V 50/60Hz 120x120 for 46725	38	AL766	Cord for Panels for 46725	39

# Electrical Schematics

Model CE-IT-0500 46725

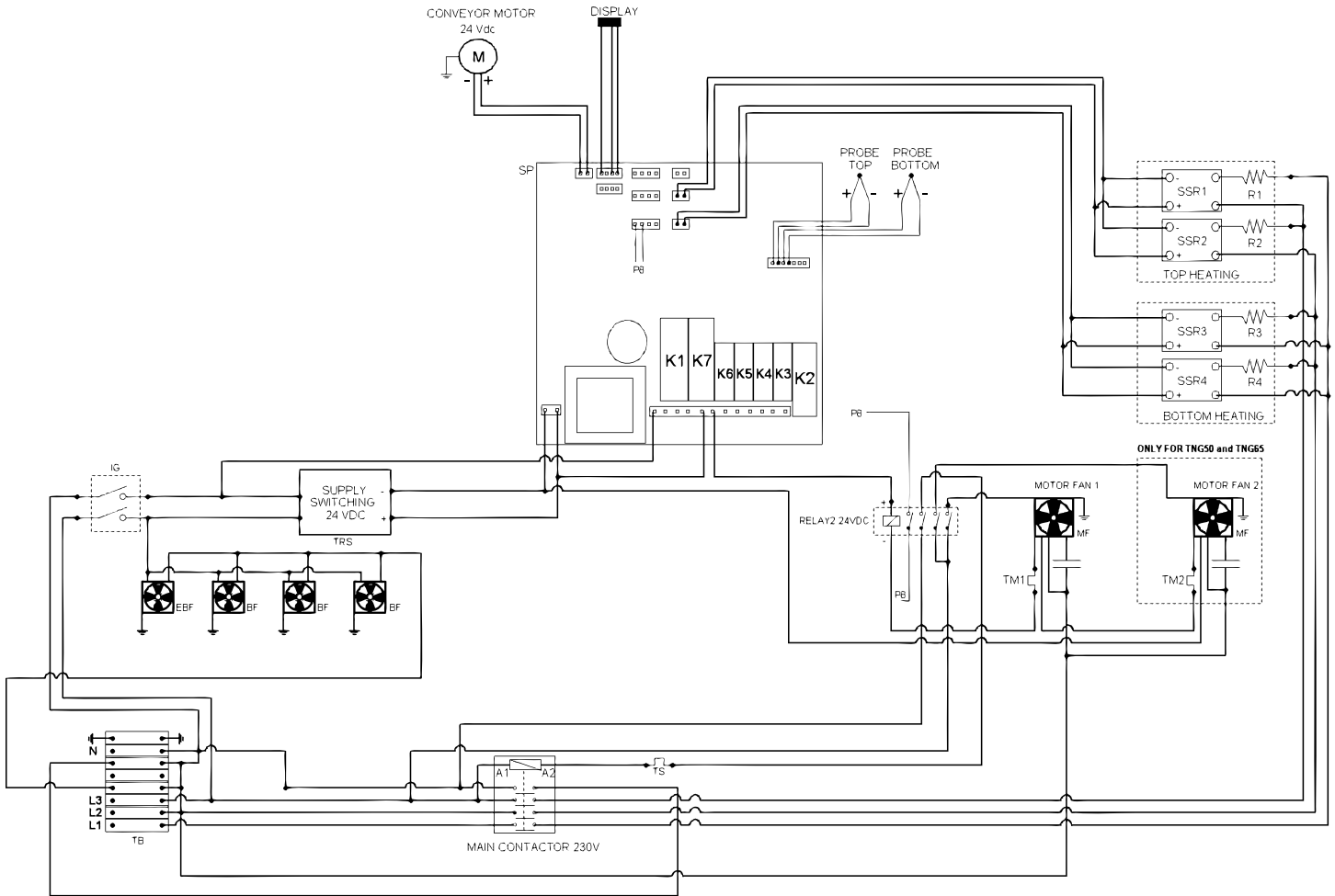

Description	Position	Description	Position	Description	Position
Burner Compartment Fans	BF	Neutral Line	N	Solid State Lower Relay	SSR1-SSR2
Technical Compartment Fans	EBF	Upper Heating Element	R1-R2	Motor Heat Protection	TM1-TM2
EMC Filter	FAD1-FAD2	Lower Heating Element	R3-R4	Transformer	TRS
Main Switch	IG	Power Electronic Card	SP	Manual Reset Safety Thermostat	TS
Phase Line	L1-L2-L3	Solid State Upper Relay	SSR1-SSR2		







# Warranty Registration

Thank you for purchasing an Omcan product. To register your warranty for this product, complete the information below, tear off the card at the perforation and then send to the address specified below. You can also register online by visiting:

Merci d'avoir acheté un produit Omcan. Pour enregistrer votre garantie pour ce produit, complétez les informations ci-dessous, détachez la carte au niveau de la perforation, puis l'envoyer à l'adresse spécifiée ci-dessous. Vous pouvez également vous inscrire en ligne en visitant:

Gracias por comprar un producto Omcan usted. Para registrar su garantía para este producto, complete la información a continuación, cortar la tarjeta en la perforación y luego enviarlo a la dirección indicada a continuación. También puede registrarse en línea en:

<https://omcan.com/warranty-registration/>

For mailing in Canada

Pour postale au Canada

Por correo en Canadá

**OMCAN**

PRODUCT WARRANTY REGISTRATION

3115 Pepper Mill Court,

Mississauga, Ontario

Canada, L5L 4X5

For mailing in the US

Pour diffusion aux États-Unis

Por correo en los EE.UU.

**OMCAN**

PRODUCT WARRANTY REGISTRATION

4450 Witmer Industrial Estates, Unit 4,

Niagara Falls, New York

USA, 14305

*or email to: [service@omcan.com](mailto:service@omcan.com)*



Purchaser's Information

Name: \_\_\_\_\_

Address: \_\_\_\_\_

City: \_\_\_\_\_ Province or State: \_\_\_\_\_ Postal or Zip: \_\_\_\_\_

Country: \_\_\_\_\_

Dealer from which Purchased: \_\_\_\_\_

Dealer City: \_\_\_\_\_ Dealer Province or State: \_\_\_\_\_

Invoice: \_\_\_\_\_

Model Name: \_\_\_\_\_ Model Number: \_\_\_\_\_

Machine Description: \_\_\_\_\_

Date of Purchase (MM/DD/YYYY): \_\_\_\_\_

Would you like to extend the warranty?  Yes  No

Company Name: \_\_\_\_\_

Telephone: \_\_\_\_\_

Email Address: \_\_\_\_\_

Type of Company:

Restaurant  Bakery  Deli

Butcher  Supermarket  Caterer

Institution (specify): \_\_\_\_\_

Other (specify): \_\_\_\_\_

Serial Number: \_\_\_\_\_

Date of Installation (MM/DD/YYYY): \_\_\_\_\_

**Thank you for choosing Omcan | Merci d'avoir choisi Omcan | Gracias por elegir Omcan**



Since 1951 Omcan has grown to become a leading distributor of equipment and supplies to the North American food service industry. Our success over these many years can be attributed to our commitment to strengthen and develop new and existing relationships with our valued customers and manufacturers. Today with partners in North America, Europe, Asia and South America, we continually work to improve and grow the company. We strive to offer customers exceptional value through our qualified local sales and service representatives who provide convenient access to over 6,500 globally sourced products.

---

Depuis 1951 Omcan a grandi pour devenir un des “leaders” de la distribution des équipements et matériel pour l’industrie des services alimentaires en Amérique du Nord. Notre succès au cours de ces nombreuses années peut être attribué à notre engagement à renforcer et à développer de nouvelles et existantes relations avec nos clients et les fabricants de valeur. Aujourd’hui avec des partenaires en Amérique du Nord, Europe, Asie et Amérique du Sud, nous travaillons continuellement à améliorer et développer l’entreprise. Nous nous efforçons d’offrir à nos clients une valeur exceptionnelle grâce à nos ventes locales qualifiées et des représentants de service qui offrent un accès facile à plus de 6500 produits provenant du monde entier.

---

Desde 1951 Omcan ha crecido hasta convertirse en un líder en la distribución de equipos y suministros de alimentos en América del Norte industria de servicios. Nuestro éxito en estos años se puede atribuir a nuestro compromiso de fortalecer y desarrollar nuevas relaciones existentes con nuestros valiosos clientes y fabricantes. Hoy con socios de América del Norte, Europa, Asia y América del Sur, que trabajan continuamente para mejorar y crecer la empresa. Nos esforzamos por ofrecer a nuestros clientes valor excepcional a través de nuestro local de ventas y representantes de los servicios que proporcionan un fácil acceso a más de 6,500 productos con origen a nivel mundial.

