



Food Dehydrator
Model CE-CN-0010-D
Item 43222
Instruction Manual



Revised - 03/10/2020



Toll Free: 1-800-465-0234
Fax: 905-607-0234
Email: service@omcan.com
www.omcan.com

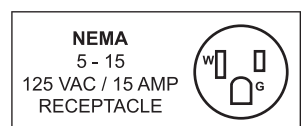

Table of Contents

Model CE-CN-0010-D

Section	Page
General Information -----	3 - 4
Safety and Warranty -----	4 - 7
Technical Specifications -----	7
Operation -----	7 - 11
Maintenance -----	11
Troubleshooting -----	12
Parts Breakdown -----	12 - 13
Electrical Schematics -----	14
Warranty Registration -----	15



General Information

Omcan Manufacturing and Distributing Company Inc., Food Machinery of America, Inc. dba Omcan and Omcan Inc. are not responsible for any harm or injury caused due to any person's improper or negligent use of this equipment. The product shall only be operated by someone over the age of 18, of sound mind, and not under the influence of any drugs or alcohol, who has been trained in the correct operation of this machine, and is wearing authorized, proper safety clothing. Any modification to the machine voids any warranty, and may cause harm to individuals using the machine or in the vicinity of the machine while in operation.

CHECK PACKAGE UPON ARRIVAL

Upon receipt of an Omcan shipment please inspect for external damage. If no damage is evident on the external packaging, open carton to ensure all ordered items are within the box, and there is no concealed damage to the machine. If the package has suffered rough handling, bumps or damage (visible or concealed), please note it on the bill of lading before accepting the delivery and contact Omcan within 24 hours, so we may initiate a claim with the carrier. A detailed report on the extent of the damage caused to the machine must be filled out within three days, from the delivery date shown in the shipping documents. Omcan has no recourse for damaged products that were shipped collect or third party.

Before operating any equipment, always read and familiarize yourself with all operation and safety instructions.

Omcan would like to thank you for purchasing this machine. It's of the utmost importance to save these instructions for future reference. Also save the original box and packaging for shipping the equipment if servicing or returning of the machine is required.

Omcan Fabrication et distribution Compañie Limité et Food Machinery d'Amérique, dba Omcan et Omcan Inc. ne sont pas responsables de tout dommage ou blessure causé du fait que toute personne ait utilisé cet équipement de façon irrégulière. Le produit ne doit être exploité que par quelqu'un de plus de 18 ans, saine d'esprit, et pas sous l'influence d'une drogue ou d'alcool, qui a été formé pour utiliser cette machine correctement, et est vêtu de vêtements de sécurité approprié. Toute modification de la machine annule toute garantie, et peut causer un préjudice à des personnes utilisant la machine ou des personnes à proximité de la machine pendant son fonctionnement.

VÉRIFIEZ LE COLIS DÈS RÉCEPTION

Dès réception d'une expédition d'Omcan veuillez inspecter pour dommages externes. Si aucun dommage n'est visible sur l'emballage externe, ouvrez le carton afin de s'assurer que tous les éléments commandés sont dans la boîte, et il n'y a aucun dommage dissimulé à la machine. Si le colis n'a subi aucune mauvaises manipulations, de bosses ou de dommages (visible ou cachée), notez-le sur le bond de livraison avant d'accepter la livraison et contactez Omcan dans les 24 heures qui suivent, pour que nous puissions engager une réclamation auprès du transporteur. Un rapport détaillé sur l'étendue des dommages causés à la machine doit être rempli dans un délai de trois jours, à compter de la date de livraison indiquée dans les documents d'expédition. Omcan n'a aucun droit de recours pour les produits endommagés qui ont été expédiés ou cueilli par un tiers transporteur.

General Information

Avant d'utiliser n'importe quel équipement, toujours lire et vous familiariser avec toutes les opérations et les consignes de sécurité.

Omcan voudrais vous remercier d'avoir choisi cette machine. Il est primordial de conserver ces instructions pour une référence ultérieure. Également conservez la boîte originale et l'emballage pour l'expédition de l'équipement si l'entretien ou le retour de la machine est nécessaire.

Omcan Empresa De Fabricacion Y Distribucion Inc. Y Maquinaria De Alimentos De America, Inc. dba Omcan y Omcan Inc. no son responsables de ningun daño o perjuicio causado por cualquier persona inadecuada o el uso descuidado de este equipo. El producto solo podra ser operado por una persona mayor de 18 años, en su sano juicio y no bajo alguna influencia de droga o alcohol, y que este ha sido entrenado en el correcto funcionamiento de esta máquina, y ésta usando ropa apropiada y autorizada. Cualquier modificación a la máquina anula la garantía y puede causar daños a las personas usando la máquina mientras esta en el funcionamiento.

REVISE EL PAQUETE A SU LLEGADA

Tras la recepcion de un envio Omcan favor inspeccionar daños externos. Si no hay daños evidentes en el empaque exterior, Habra el carton para asegurarse que todos los articulos solicitados estén dentro de la caja y no encuentre daños ocultos en la máquina. Si el paquete ha sufrido un manejo de poco cuidado, golpes o daños (visible o oculto) por favor anote en la factura antes de aceptar la entrega y contacte Omcan dentro de las 24 horas, de modo que podamos iniciar una reclamación con la compañía. Un informe detallado sobre los daños causados a la máquina debe ser llenado en el plazo de tres días, desde la fecha de entrega que se muestra en los documentos de envío. Omcan no tiene ningun recurso por productos dañados que se enviaron a recoger por terceros.

Antes de utilizar cualquier equipo, siempre lea y familiarizarse con todas las instrucciones de funcionamiento y seguridad.

Omcan le gustaría darle las gracias por la compra de esta máquina. Es de la mayor importancia para salvar estas instrucciones para futuras consultas. Además, guarda la caja original y el embalaje para el envío del equipo si servicio técnico o devolución de la máquina que se requiere.

Safety and Warranty

When using electrical appliances, basic safety precautions should always be followed, including the following:

1. Read all instructions carefully and completely.
2. For commercial use only.
3. Do not touch hot surfaces.
4. Protect against electrical shock by keeping all cords, plugs, and other electrical components away from



Safety and Warranty

water or other liquids.

5. Unplug this unit when not in use and before cleaning.
6. Allow the unit to cool before putting on or taking off parts.
7. Do not operate this or any appliance with a damaged electrical cord or plug.
8. Do not operate this or any appliance after it has malfunctioned or been damaged in any way.
9. Do not use outdoors.
10. Do not place on or near a hot gas or electric burner.
11. Attach plug to appliance first, then plug electrical cord into the wall outlet.
12. Disconnect the unit by turning the power switch to "OFF", then removing the electrical plug from the wall outlet.
13. Do not use appliance for any application other than intended use.
14. Do not insert metal utensils or over-sized foods into this unit as they may cause a fire and heighten the risk of electrical shock.
15. Do not store any item on top of this unit when in operation.
16. Do not allow this dehydrator to touch or be covered by flammable material, such as curtains, draperies, walls, etc., when in operation.
17. Do not clean with metal scouring pads as pieces can break off and touch electrical components, heightening the risk of electrical shock.
18. Never place materials such as paper, cardboard, plastic, etc. in this dehydrator.
19. Do not cover interior of this unit with metal foil as it may cause the dehydrator to overheat.
20. Avoid scratching the surface or nicking the edges of this unit. Do not put the slim or sharp articles beyond the net interior, it may choke the fan and cause product failure.
21. Turn the appliance off by turning the power switch button to the "OFF" position.
22. Note that the use of accessories not recommended by the manufacturer may result in injury.
23. Children should be supervised to ensure that they do not play with the dehydrator.
24. This appliance is not intended for use by persons (including children) with reduced physical sensory or mental capabilities, or lack of experience and knowledge, unless they have been given supervision or instruction concerning use of the appliance by a person responsible for their safety.
25. When using the appliance in shops, snack bars, hotels etc., check the voltage and outlet to make sure the appliance is correctly connected with power.
26. Place unit on a flat surface that is well ventilated.

NOTE: Save these instructions for future reference.

FOOD SAFETY

There are basic rules to follow when handling food. They are COOK, SEPARATE, CLEAN, and CHILL.

COOK

It's crucial to cook food to a safe internal temperature to destroy bacteria that is present. The safety of hamburgers and other foods made with ground meat has been receiving a lot of attention lately, and with good reason. When meat is ground, the bacteria present on the surface is mixed throughout the ground mixture. If this ground meat is not cooked to at least 160-165°F(71-74°C), bacteria will not be destroyed and there's a good chance you will get sick.

Solid pieces of meat like steaks and chops don't have dangerous bacteria like E. coli on the inside, so they can

Safety and Warranty

be served more rare. Still, any beef cut should be cooked to an internal temperature of at least 145°F(63°C) (medium rare). The safe temperature for poultry is 180°F(82°C) and solid cuts of pork should be cooked to 160°F(71°C). Eggs should be thoroughly cooked too. If you are making a meringue or other recipe that uses uncooked eggs, buy specially pasteurized eggs or use prepared meringue powder.

SEPARATE

Foods that will be eaten uncooked and foods that will be cooked before eating **MUST ALWAYS** be separated. Cross-contamination occurs when raw meats or eggs come in contact with foods that will be eaten uncooked. This is a major source of food poisoning. Always double-wrap raw meats and place them on the lowest shelf in the refrigerator so there is no way juices can drip onto fresh produce. Then use the raw meats within 1-2 days of purchase, or freeze for longer storage. Defrost frozen meats in the refrigerator, not on the counter.

When grilling or cooking raw meats or fish, make sure to place the cooked meat on a clean platter. Don't use the same platter you used to carry the food out to the grill. Wash the utensils used in grilling after the food is turned for the last time on the grill, as well as spatulas and spoons used for stir-frying or turning meat as it cooks.

Make sure to wash your hands after handling raw meats or raw eggs. Washing hands with soap and water, or using a pre-moistened antibacterial towelette is absolutely necessary after you have touched raw meat or raw eggs. Not washing hands and surfaces while cooking is a major cause of cross-contamination.

CLEAN

Wash your hands and work surfaces frequently when you are cooking. Washing with soap and warm water for at least 15 seconds, then dry with a paper towel.

CHILL

Chilling food is very important. The danger zone where bacteria multiply is between 39°F(4°C) and 43°F(6°C). Your refrigerator should be set to 39°F(4°C) or below; your freezer should be -62°F(-17°C) or below. Simple rule: serve hot foods hot, cold foods cold. Use chafing dishes or hot plates to keep food hot while serving. Use ice water baths to keep cold foods cold. Never let any food sit at room temperature for more than 2 hours - 1 hour if the ambient temperature is 90°F(32°C) or above. When packing for a picnic, make sure the foods are already chilled when they go into the insulated hamper. The hamper won't chill food - it just keeps food cold when properly packed with ice. Hot cooked foods should be placed in shallow containers and immediately refrigerated so they cool rapidly. Make sure to cover foods after they are cool.

1 YEAR PARTS AND LABOUR BENCH WARRANTY

Within the warranty period, contact Omcan Inc. At 1-800-465-0234 to schedule a drop off to either an Omcan authorized service depot in the area, or to an Omcan Service warehouse to repair the equipment.

Unauthorized maintenance will void the warranty. Warranty covers electrical and part failures, not improper use.

Please see <https://omcan.com/disclaimer> for complete info.



Safety and Warranty

WARNING:

The packaging components are classified as normal solid urban waste and can therefore be disposed of without difficulty.

In any case, for suitable recycling, we suggest disposing of the products separately (differentiated waste) according to the current norms.

DO NOT DISCARD ANY PACKAGING MATERIALS IN THE ENVIRONMENT!

Technical Specifications

Model	CE-CN-0010-D
Power	1000 W
Number of Racks	10
Thermostat Control	29 - 71°C / 85 - 160°F
Shelf Size	16" x 14.3" / 406 x 362mm
Electrical	120V / 60Hz / 1
Weight	30.4 lbs. / 13.8 kgs.
Packaging Weight	35 lbs. / 15.9 kgs.
Dimensions	16.5" x 20" x 17" / 419 x 508 x 432mm
Packaging Dimensions	20.5" x 23" x 20" / 521 x 584 x 508mm
Item Number	43222

Operation

BEFORE USING YOUR DEHYDRATOR

Before dry anything in your dehydrator for the first time, please follow these simple instructions:

Using a small amount of detergent, wash the handle and food racks with soapy water. (NOTE: Do not use a spray or abrasive polishing agent.) Gently wipe down interior walls with a damp cloth. While washing this unit, do not to touch the electric heating element and fan. Do not soak the inside of the dehydrator with water.

After washing and thoroughly drying the surfaces noted above, place the food racks back inside the dehydrator.

Operation

Cover the dehydrator and preheat it to its highest temperature setting for 5 minutes.

Turn off the heating elements and open the dehydrator front panel in order to remove any smoky residue from inside the dehydrator. The heating elements are well lubricated and this initial use will help burn off the extra grease. A light amount of smoke is normal during this process.

USING YOUR DEHYDRATOR

To start your dehydrator, you need to turn the power switch on, the unit will be powered then. Turn on the timer to set a time, the fan start working. Then turn on the thermostat dial to set a desired temperature, the heating element start heating.

CAUTION: During the dehydrating process, make sure that no metal accessory comes in contact with the electric fan and heating elements.

CAUTION: Foods dehydrated in this unit will be hot. Wear protective hand coverings when reaching into dehydrator to retrieve food.

TYPICAL OPERATION SEQUENCE

ACTION	RESULT
Plug in your dehydrator.	Power is connected but power light will go on after turning the power switch button.
Turn on the timer dial	Convection fan start working
Turn on the thermostat dial	Heating element start working.
Timer reaches zero.	Timer chimes.
Unload dehydrator.	Product will be dehydrated/hot; use caution removing it from the dehydrator.

TIMER

The range of the timer on this unit is 0-12 hours. Turning the timer to the "OFF" position, the dehydrating time is over and the timer will "ding" to alert.

If you need to reset the dehydrating time while the dehydrator is in operation, simply turn the timer to a new position. The dehydrator will reset the time according to the revised requirement without needing to be turned off.

When the set dehydrating time has been reached, the unit will chime and the heating elements will automatically shut off.

TEMPERATURE CONTROL KNOB

The temperature range of this unit is 85-160 degrees Fahrenheit on 120V models. This thermostatic switch controls the temperature inside the dehydrator and helps to maintain the proper temperature during various dehydrating applications.

PROTECTION COMPONENT

If the temperature of this dehydrator reaches an unsafe limit, the electrical components will shut off and it will stop operating in order to prevent overheating.

PRE-TREATMENT OF FOODS

As with most types of cooking, proper preparation is essential for successful results. Adhering to a few basic guidelines will generally increase the quality of your dried foods and decrease the amount of time necessary to dry them.

Pre-treated foods often taste better and have a better appearance than non-treated foods. There are several methods to pre-treat food to prevent oxidation, which will darken apples, pears, peaches and bananas while drying.

- Remove any pits, skin, cores or bones.
- Shred, slice or dice the food uniformly. Slices should be between 0.3-0.6 cm thick. Meats should be cut not more than 1.9 cm thick.
- **IMPORTANT:** Before placing the meat in a Dehydrator, it is **HIGHLY RECOMMENDED** to heat the meat to 160°F(71°C), poultry to 165°F(74°C), as measured with a food thermometer in an oven **BEFORE** starting the dehydration process. This step assures that any bacteria present will be destroyed by wet heat. After heating to 160°F(71°C), poultry to 165°F(74°C), maintain a constant dehydrator temperature of 131-140°F(55-60°C) during the drying process. The minimum recommended temperature for drying meats is 145°F(63°C). Temperatures below 145°F(63°C) are **NOT** recommended.
- Drying into jerky requires a lot of attention. It must be cleaned and de-boned properly and rinsed thoroughly to ensure that all the blood is washed away.
- Soak cut fruit in either lemon or pineapple juice for a few minutes before placing out on the Trays.
- Use an ascorbic acid mix which can be purchased in most health food stores or pharmacies. It may come in either powder or tablet form. Dissolve approximately 2-3 tablespoons into 1 liter of water. Soak the fruit slices into the solution for 2-3 minutes, then place on the Trays.
- Fruits with a wax coating (figs, peaches, grapes, blueberries, prunes, etc.) should be dipped in boiling water to remove the wax. This allows moisture to escape easily when dehydrating.

MAKING JERKY

- Use the best quality meats. Meats, fish and poultry should be lean and fresh. Remove as much fat as possible before dehydrating. Using lean meat will help the meat dry faster and aid in cleanup by decreasing the drippings. Ground meat should be 80% to 90% lean. Ground turkey, venison, buffalo and elk are other excellent choices for jerky.

Operation

- Jerky seasonings are available for all tastes. Whenever making jerky, treat the mixture with cure (sodium nitrate). The cure is used to help prevent botulism during drying at low temperatures.
- Keep raw meats and their juices away from other foods. Marinate meats in the refrigerator. Do not leave meats un-refrigerated. Prevent cross-contamination by storing dried jerky away from raw meat. Always wash hands thoroughly with soap and water before and after working with meat products. Use clean equipment and utensils.
- Keep meat and poultry refrigerated at 41°F(5°C) or slightly below; use or freeze ground beef and poultry within 2 days; whole red meats, within 3 to 5 days. Defrost frozen meat in the refrigerator, not on the counter.
- Special considerations must be made when using venison or other wild game, as it can become heavily contaminated during field dressing. Venison is often held at temperatures that could potentially allow bacteria to grow, such as when it is being transported. Refer to the USDA Meat and Poultry Department for further questions or information on meat and food safety.
- **IMPORTANT:** Before placing the meat in a Dehydrator, it is **HIGHLY RECOMMENDED** to heat the meat to 160°F(71°C), poultry to 165°F(74°C), as measured with a food thermometer in an oven **BEFORE** starting the dehydration process. This step assures that any bacteria present will be destroyed by wet heat. After heating to 160°F(71°C), poultry to 165°F(74°C), maintain a constant dehydrator temperature of 145-154°F(63-68°C) during the drying process. Temperatures below 145°F(63°C) are **NOT** recommended.
- If using a marinade, shake off excess liquid before placing the meat on the Trays.
- Evenly space the meat in single layers approximately 0.64 cm apart on the Trays.
- You may need to blot fat droplets from the surface of the meat occasionally using a paper towel.
- Drying times may vary based on many circumstances including but not limited to: the relative humidity of the room, the temperature of the meat at the beginning of the drying process, the amount of meat in the Dehydrator, the leanness of the meat, etc.
- Always allow jerky to cool before taste testing to void burns.

STORING JERKY

- First wrap jerky in aluminum foil or wax paper, then store in a thick plastic food storage bag, metal, glass or plastic containers. Remove as much air as possible before sealing. Seal tightly.
- Vacuum sealing is ideal for keeping dried foods.
- Jerky should be stored in a cool, dark, dry place between 50-60°F(10-16°C) or lower. Jerky can be stored, if properly dried, at room temperature for 1 or 2 months. To extend shelf life to up to 6 months, store jerky in the freezer.
- Be sure to label and date all packages with contents, ingredients, original weight and date processed.
- Keep a journal to help improve drying techniques.

RE-HYDRATING FOODS

WARNING! DO NOT soak food at room temperature. Soaking at room temperature allows harmful bacteria to grow. Follow the “Food Safety” guidelines outlined in this manual.

- Dehydrated food can be re-hydrated by soaking in cold water for 3-5 minutes or for 2-6 hours in the refrigerator in water. Use 1 cup of water for 1 cup of dehydrated food. Once re-hydrated, the food can be cooked normally. Soaking foods in warm water will speed up the process however; it may result in loss of

Operation

flavor.

- Do not add seasoning. Adding salt or sugar during re-hydration may change the flavor of the food.
- To make stewed fruits or vegetables, add 2 cups of water and simmer until tender.
- Consume dehydrated foods as soon as possible once the storage container is opened. Keep any unused portions in the refrigerator to avoid contamination.

TIPS

- Use the best quality foods. Fruits and vegetables in peak season have more nutrients and more flavor. Do not use food with bruises or blemishes. Bad fruits and vegetables may spoil the entire batch.
- Use the best quality meats. Meats, fish and poultry should be lean and fresh. Remove as much fat as possible before dehydrating. Do not overlap foods. Lay foods flat on the Trays.
- Check dryness after a few hours, then check every two hours until dehydrated. Open or cut down the middle if a few samples to check internal dryness. If the food is still moist, dehydrate longer.
- Use the Drying Guide on the Control Panel as reference for proper temperature settings. If the heat is set too high, the food may case harden, meaning the food is dried at too high of a temperature and the food was only dry on the outside, not the inside. If the temperature is too low, the drying time will increase.

Remember, foods will shrink approximately 1/4 to 1/2 their original size and weight during the dehydration process, so pieces should not be kept too small. One pound of raw meat will yield approximately 0.2 kg of jerky.

Do not place items to be dried on the Drip Tray, there will be no circulation of air on this Tray. Clean the Drip Tray periodically during dehydration for easier clean-up.

Maintenance

CLEANING AND MAINTENANCE

To clean, first remove the power cord's plug from the wall outlet. Wait for the dehydrator to cool. Use a damp cloth or sponge to gently wipe down the inside of the unit. Avoid soaking the inside of the dehydrator or washing it in running water as this will cause serious damage to the unit.

Troubleshooting

Problem	Solution
The dehydrator does not work after being switched on.	Make sure dehydrator is plugged in.
	Be sure that the timer is set.
	Be sure that the temperature control knob is set.
There is a metallic sound when the dehydrator is in use.	Do not attempt to dismantle the dehydrator.
	Contact your service agent right away to examine the fan.
Food is often over dried or not dried, even when operate according to the recipe.	Check that the fan motor is operating normally.
	Contact your service agent to examine the temperature control knob.

REFERENCE

Item Number	Model Number	Description	Manufacturer Model Number
43222	CE-CN-0010-D	Food Dehydrator Stainless Steel 120V/60HZ/1 1000W 10 Racks with Thermostat Control and Timer cQPSus	FK-02

Parts Breakdown

Model CE-CN-0010-D 43222

Item No.	Description	Position	Item No.	Description	Position	Item No.	Description	Position
61895	Power Cord for FK-02	1	61903	Temperature Limiter for FK-02	9	61911	Handle for FK-02	17
61896	Block Terminal for FK-02	2	61904	Thermostat Holding Plate for FK-02	10	61912	Left Rack Assembly for FK-02	18
61897	Rear Board for FK-02	3	61905	Heating Element Assembly for FK-02	11	61913	Top Board for FK-02	19
61898	Fan Assembly for FK-02	4	61906	Shell for FK-02	12	61914	Control Board Plate for FK-02	20
61899	Thermostat for FK-02	5	61907	Foot for FK-02	13	61915	Switch for FK-02	21
61900	Insulation Plate for FK-02	6	10925	Tray for FK-02	14	61916	Timer Knob for FK-02	22
61901	Right Rack Assembly for FK-02	7	61909	Quarries Net for FK-02	15	61917	Thermostat Knob for FK-02	23
61902	Timer for FK-02	8	61910	Front Panel for FK-02	16			

Parts Breakdown

Model CE-CN-0010-D 43222

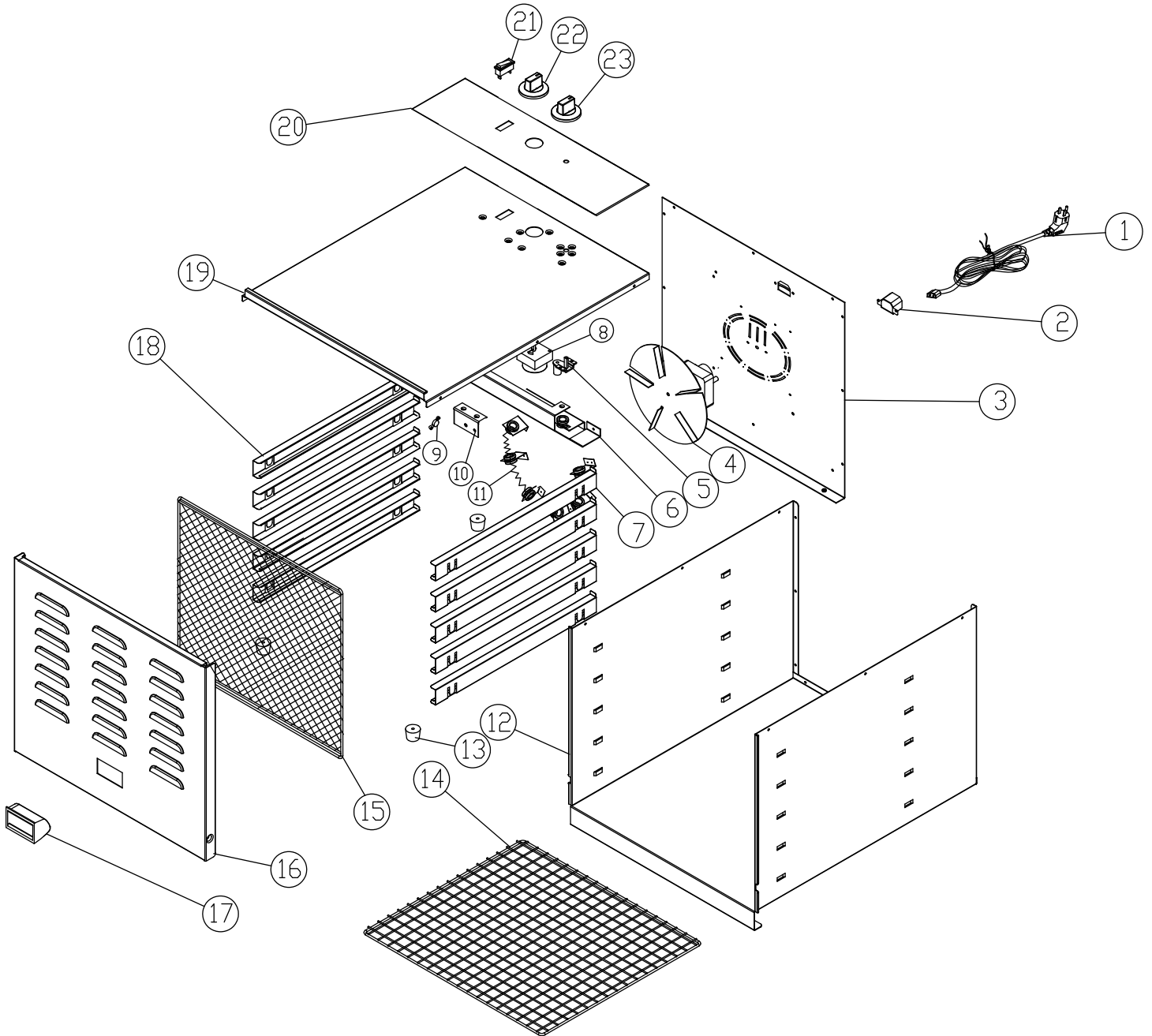

Electrical Schematics

Model CE-CN-0010-D 43222

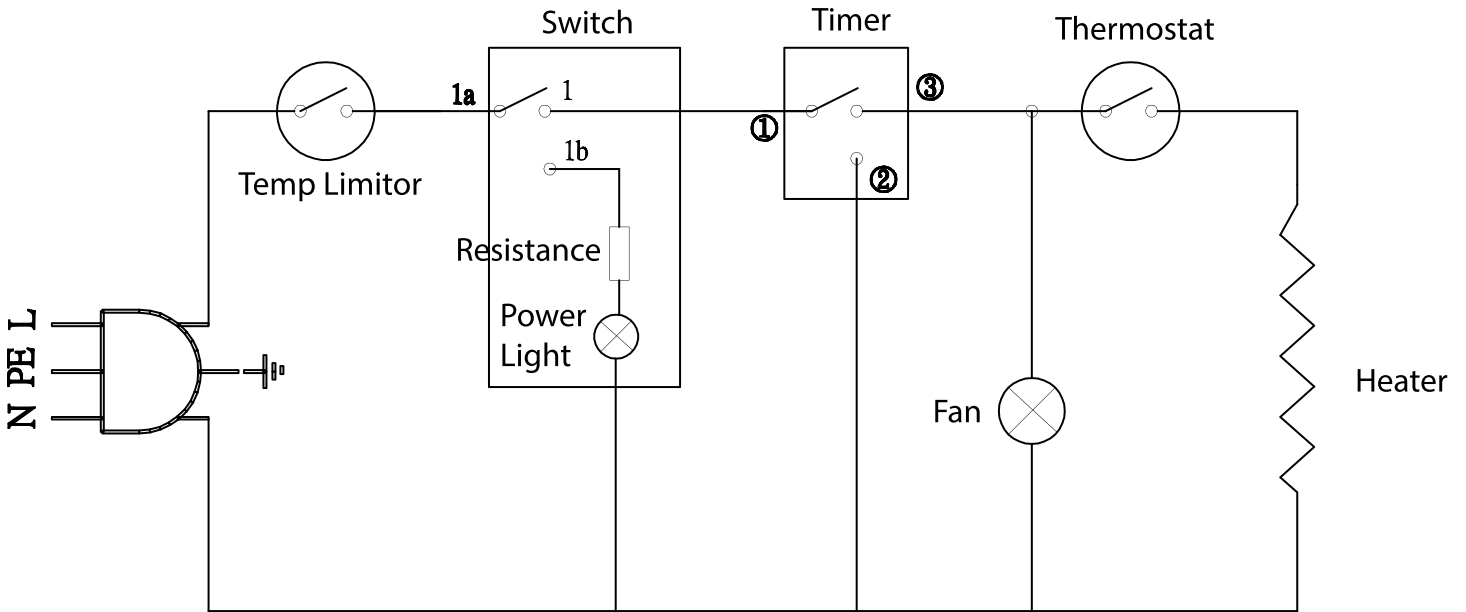



Warranty Registration

Thank you for purchasing an Omcan product. To register your warranty for this product, complete the information below, tear off the card at the perforation and then send to the address specified below. You can also register online by visiting:

Merci d'avoir acheté un produit Omcan. Pour enregistrer votre garantie pour ce produit, complétez les informations ci-dessous, détachez la carte au niveau de la perforation, puis l'envoyer à l'adresse spécifiée ci-dessous. Vous pouvez également vous inscrire en ligne en visitant:

Gracias por comprar un producto Omcan usted. Para registrar su garantía para este producto, complete la información a continuación, cortar la tarjeta en la perforación y luego enviarlo a la dirección indicada a continuación. También puede registrarse en línea en:

<https://omcan.com/warranty-registration/>

For mailing in Canada

Pour postale au Canada

Por correo en Canadá

OMCAN

PRODUCT WARRANTY REGISTRATION

3115 Pepper Mill Court,

Mississauga, Ontario

Canada, L5L 4X5

For mailing in the US

Pour diffusion aux États-Unis

Por correo en los EE.UU.

OMCAN

PRODUCT WARRANTY REGISTRATION

4450 Witmer Industrial Estates, Unit 4,

Niagara Falls, New York

USA, 14305

or email to: service@omcan.com



Purchaser's Information

Name: _____

Address: _____

City: _____ Province or State: _____ Postal or Zip: _____

Country: _____

Dealer from which Purchased: _____

Dealer City: _____ Dealer Province or State: _____

Invoice: _____

Model Name: _____ Model Number: _____

Machine Description: _____

Date of Purchase (MM/DD/YYYY): _____

Would you like to extend the warranty? Yes No

Company Name: _____

Telephone: _____

Email Address: _____

Type of Company:

Restaurant Bakery Deli

Butcher Supermarket Caterer

Institution (*specify*): _____

Other (*specify*): _____

Serial Number: _____

Date of Installation (MM/DD/YYYY): _____

Thank you for choosing Omcan | Merci d'avoir choisi Omcan | Gracias por elegir Omcan



Since 1951 Omcan has grown to become a leading distributor of equipment and supplies to the North American food service industry. Our success over these many years can be attributed to our commitment to strengthen and develop new and existing relationships with our valued customers and manufacturers. Today with partners in North America, Europe, Asia and South America, we continually work to improve and grow the company. We strive to offer customers exceptional value through our qualified local sales and service representatives who provide convenient access to over 5,000 globally sourced products.

Depuis 1951 Omcan a grandi pour devenir un des “leaders” de la distribution des équipements et matériel pour l’industrie des services alimentaires en Amérique du Nord. Notre succès au cours de ces nombreuses années peut être attribué à notre engagement à renforcer et à développer de nouvelles et existantes relations avec nos clients et les fabricants de valeur. Aujourd’hui avec des partenaires en Amérique du Nord, Europe, Asie et Amérique du Sud, nous travaillons continuellement à améliorer et développer l’entreprise. Nous nous efforçons d’offrir à nos clients une valeur exceptionnelle grâce à nos ventes locales qualifiées et des représentants de service qui offrent un accès facile à plus de 5000 produits provenant du monde entier.

Desde 1951 Omcan ha crecido hasta convertirse en un líder en la distribución de equipos y suministros de alimentos en América del Norte industria de servicios. Nuestro éxito en estos años se puede atribuir a nuestro compromiso de fortalecer y desarrollar nuevas relaciones existentes con nuestros valiosos clientes y fabricantes. Hoy con socios de América del Norte, Europa, Asia y América del Sur, que trabajan continuamente para mejorar y crecer la empresa. Nos esforzamos por ofrecer a nuestros clientes valor excepcional a través de nuestro local de ventas y representantes de los servicios que proporcionan un fácil acceso a más de 5,000 productos con origen a nivel mundial.

