



Grand Rapids, Michigan, U.S.A. 49504-5298

## **USER'S OPERATING AND INSTRUCTION MANUAL**

### **MODEL 2003R**

BREAD SLICER

**INDEX**

<u>Section</u>	<u>Page No.</u>
SAFETY INSTRUCTIONS.....	GEN861015
DESCRIPTION/SPECIFICATIONS.....	2003S20027
OPERATION INSTRUCTIONS.....	2003S20028
MAINTENANCE.....	2003S20029
TROUBLESHOOTING.....	2003S20030-1/3
MAIN FRAME ASSEMBLY.....	2003S20039
BLADE & CLUTCH ASSEMBLY.....	2003S20032
CUTOFF ARM ASSEMBLY.....	2003S20033
PUSHER WITH STEPPER ASSEMBLY.....	2003S20040
TABLE & COVER ASSEMBLY.....	2003S20041
CLUTCH ASSEMBLY.....	2003S20036
ELECTRICAL SUB-PANEL ASSEMBLY.....	2003S20037
ELECTRICS 1-60-115 ASSEMBLY.....	2003S20038
WARRANTY.....	GEN040225
WARRANTY PROCEDURE.....	GEN040226
RETURNED PARTS POLICY.....	GEN040227

**THIS PAGE WAS INTENTIONALLY  
LEFT BLANK.**

---

## SAFETY INSTRUCTIONS

Various safety devices and methods of guarding have been provided on this machine. It is essential, however, that machine operators and maintenance personnel observe the following safety precautions. Improper installation or operation of this equipment may cause injury to personnel or damage to equipment.

1. Read this manual before attempting to operate your machine. Never allow an untrained person to operate or service this machine.
2. Connect the machine to a properly grounded electrical supply that matches the requirements shown on the electrical specification plate and follow specifications of local electrical codes.
3. Disconnect and lock-out the machine from the power supply before cleaning or servicing.
4. Check and secure all guards before starting the machine.
5. Observe all caution and warning labels affixed to the machine.
6. Use only proper replacement parts.
7. Do not wear loose fitting clothing or loose hair. Shirt tails should be tucked in.
8. Wear proper personal safety equipment.
9. Keep Hands away from the moving parts of this machine while it is in operation.
10. In addition to these general safety instructions, also follow the more specific safety instructions given for the different areas of the machine in the operating instructions.

<b><u>WARNING</u></b>
-----------------------

**DO NOT USE FOR OTHER THAN ORIGINALLY INTENDED PURPOSE**

## DESCRIPTION/SPECIFICATION

### Description

The Oliver Model 2003R is a variable slice thickness bread slicer which utilizes a new and innovative way to slice bread. The bread is moved past a circular blade, which is mounted to a moving arm, cutting each slice individually to whatever thickness is selected. The slicer is designed for on-demand slicing allowing your customers to choose a slice thickness which satisfies their needs.

The slicer employs a disc brake on the blade drive motor which mechanically engages to stop the blade whenever the blade is exposed due to a door being opened, or after the slicing cycle is finished.

### **NOTE**

THIS MACHINE IS NOT INTENDED TO BE USED FOR SLICING WARM, STICKY, NUT AND/OR FRUIT BREADS.

### Physical specifications

#### Product Capacities:

The slicer will process loaves up to 9 inches by 4-1/4 inches by 15 inches long.

#### Overall Machine size:

Width = 36 inches

Height = 28-1/2 inches, 30 inches with Blade Guard all the way open.

Depth = 24 inches, 48 inches with Blade Guard all the way open.

#### Net Weight:

Approximately 360 pounds.

#### Shipping Weight:

Approximately 375 pounds.

#### Slice Thickness:

3/8, 7/16, 1/2, 5/8, 3/4, 7/8, 1, and 1-1/2 inches.

#### Electrics:

3/4 Horse Power, 1 phase, 50/60 hertz, 115 Volts AC, 13 Amps,  
(20 Amp Dedicated Circuit).

3/4 Horse Power, 1 phase, 50/60 hertz, 230 Volts AC, 6.5 Amps,  
(10 Amp Dedicated Circuit).

---

---

## OPERATING INSTRUCTIONS

### 1. Automatic Diagnostic Check:

Close both doors. Turn the machine on. First the display reads “Vari-slicer” and the software version. Next, the machine will automatically perform a diagnostic check on the “end” and “home” proximity sensors (PS). You should observe the pusher going to its “end” (right) limits and “home” (left). The pusher will then return to the home position. You may then begin standard operation.

### 2. Standard Operation:

- Upon a successful completion of the diagnostic check, the machine is ready for slicing.
- Hold open the left door with left hand.
- Place loaf on table.
- Slide loaf left onto the pins on the pusher so that pins penetrate the loaf, until it is firmly against the back of the pusher.
- Close door(s).

## **NOTE**

MACHINE WILL NOT OPERATE IF EITHER DOOR IS OPEN.

- Select the appropriate thickness setting. Slicing will begin immediately.
- Wait for bread to be sliced. After the final slice, the bread will be in the right hand compartment.
- Open the right hand door and remove the loaf.
- Close the door
- Repeat above steps for each loaf.

### 3. Stopping:

If a slice gets jammed, press **STOP** to stop slicing, turn power off, disconnect, and lockout machine before trying to clear the machine.

## **CAUTION**

DO NOT OPEN DOORS WHILE SLICER IS OPERATING. DOING SO WILL CAUSE SLICING TO STOP.

**MAINTENANCE**

**WARNING**

DISCONNECT AND LOCK OUT THE MACHINE FROM THE POWER SUPPLY BEFORE CLEANING OR SERVICING. REMEMBER TO USE CARE WHENEVER YOU ARE WORKING NEAR THE BLADE.

1. Cleaning:

Use a mild detergent solution applied with a cloth or spray cleaner on all exterior and interior surfaces as necessary. Remove and empty contents of the crumb tray daily. Periodically remove the blade and clean the blade compartment.

The blade must be cleaned each day, you Do Not need to remove the blade for this. Use a mild detergent solution or spray cleaner. For harder deposits use a non scratch cleaning pad similar to Scotch-brite (tm).

2. Lubrication:

All motors and bearings are pre-lubricated and sealed, lubrication is NOT required. Do Not attempt to oil or grease the motor.

3. Changing a blade:

**WARNING**

DISCONNECT AND LOCK OUT THE MACHINE FROM THE POWER SUPPLY BEFORE CLEANING OR SERVICING. REMEMBER TO USE CARE WHENEVER YOU ARE WORKING NEAR THE BLADE.

- Open the blade guard after removing the knob (located at the top of the guard) which holds it in place. Gently pull the hinged blade guard forward, resting it all the way open.
- Remove the blade mounting screw using a 1/2 inch wrench.
- Remove the lockwasher, special washer, 2 inch diameter collar, and the circular knife.
- The blade is replaced by reversing the above procedure.
- When reinstalling the blade, make sure the beveled side faces the outfeed or toward the right side (FLAT SIDE TOWARD INFEEED or toward the left side). Make sure the blade is centered and supported on the arbor.

**NOTE**

INSTALLING THE BLADE BACKWARDS WILL RESULT IN MALFUNCTION.

---

---

## TROUBLESHOOTING GUIDE

### **WARNING**

DISCONNECT AND LOCK OUT THE MACHINE FROM THE POWER SUPPLY BEFORE SERVICING.

### **WARNING**

TROUBLESHOOTING OF THIS EQUIPMENT MUST BE PERFORMED BY QUALIFIED PERSONNEL ONLY.

Software on the 2003R is continually performing diagnostic checks on itself. The first diagnostic check occurs when the machine is first turned on.

### **SOLVING SOME PROBLEMS**

- Check display on front of machine for an explanation of any problem first.

*The Blade Is Crushing the Bread.*

- The bread may be too warm for slicing.
- A heavy build-up on the blade from slicing warm bread or sticky fruit breads can cause this type of product damage or malfunction.
- The slicer drive motor may not be running, (the slicer knife will not be rotating). The motor is protected by a motor starter, located behind the rear access panel, which may need to be reset.
- The Knife has become extremely dull and needs to be replaced.

*Slicing Begins Too Soon, The Knife Takes Several Strokes Before Product Is beneath the Knife.*

- The reflector on the inside of the Knife Cover is dirty.
- The reflector on the inside of the Knife Cover is missing.
- The “Loaf Sensor” is dirty.
- The “Loaf Sensor” has failed.

---

**SOLVING SOME PROBLEMS**- Continued

*Nothing Happens When The Machine Is Turned On.*

- Check to see if the machine is plugged in.
- Check to see if there is power at the outlet.
- Check to see if any of the circuit breakers have tripped. They are located near the lower, right hand, rear corner of the machine.

*The Knife Vibrates Excessively.*

- Loose or miss-aligned knife. Align or re-tighten as necessary.

*The Machine Makes A Loud Thumping Sound Before Making The First Slice.*

- Check for a loose blade drive V-belt, or clutch drive belt.

**MANUAL DIAGNOSTIC MODE**

- The machine may be put into Manual Diagnostic Mode to check several functions of the machine. To enter this mode, simply do the following:
  - Turn power off.
  - Depress the "1" and "2" keys simultaneously for approximately 5 seconds or until display illuminates.
  - There are nine different tests that can be performed in this mode. To exit this mode, depress "**Power**" key at any time. The tests are:
    1. **Jog Test** - The display will read "**Jog Test 3=Next**" and "**1=Left 2=Right**". Depress the "2" key to jog the pusher to the right. Depress the "1" key to jog the pusher to the left. Depress the "3" key to continue to the next test.
    2. **Knife Arm Test** - The display will read "**Knife Arm Test**" and "**Press&Hold 1 3=Next**". Depress the "1" key and hold it to turn only the arm motor on. Continue depressing it until the arm clutch engages, and the arm goes through a down-then-up cycle. Depress the "3" key to continue to the next test .
    3. **Blade Motor Test** - The display will read "**Blade Motor Test**" and "**1=on 1=off 3=next**". Depress the "1" key to turn the blade motor on. Depress the "1" key again to turn the blade motor back off. Depress the "3" key to continue to the next test.
    4. **Loaf Sensor Test** - The display will read "**Loaf Sensor Test**" and "**Not Detected 3=Next**". Insert a small piece of paper in front of the loaf sensor, between the infeed door and the blade guard. Once the beam is broken, the display will read "**Object Detected 3=Next**". Remove the piece of paper. Depress the "3" key to continue to the next test.

---

**MANUAL DIAGNOSTIC MODE**- Continued

5. **Door Test** - The display will read "**Door Test**" and "**1=Left 2=Right**". Any of the door open sensors can be checked individually by opening the infeed door, the blade guard, or the outfeed door. The display will indicate which is open. Depress the "**3**" key to continue to the next test.
6. **Slow Jog Test** - The display will read "**Slow Jog Test 3=Next**" and "**1=Left 2=Right**". Depress the "**2**" key to jog the pusher slowly to the right. Depress the "**1**" key to jog the pusher slowly to the left. Depress the "**3**" key to continue to the next test.
7. **Set Heel** - The display will read "**Set Heel 1=Down 2=Up**" and "**Heel Val = 8**". This is to program the final slice thickness. The value is in eighths of an inch. For example, Heel Val=8 would be 8/8 inch or 1 inch, or Heel Val=7 be 7/8 inch. The range of Heel Values is 6 to 12, which equates to 3/4" to 1 1/2".
8. **Continuous Cycle** - The display will read "**Continuous Cycle**" and "**1=Start 3=Next**". Depress the "**1**" key to begin the continuous cycle test. The machine will first go through its self calibration, then it will operate as if it is slicing bread even though there is no bread detected. Once the pusher gets near the blade, slicing will stop, the pusher will return to its home position. The display will read "**Slicing...**" and "**Thickness: 3/8**". The cycle will repeat itself. To exit this mode, depress the "**1**" key to stop. Depress the "**3**" key to continue to the next test.
9. **Key Pad Test** - The display will read "**Key Pad Test**". Once in this test, any key can be depressed, and the display will indicate which key it is. To exit this test, depress the "**3**" key, AND HOLD IT IN FOR APPROXIMATELY 5 SECONDS to return to the Jog Test.

**MAIN FRAME ASSEMBLY**

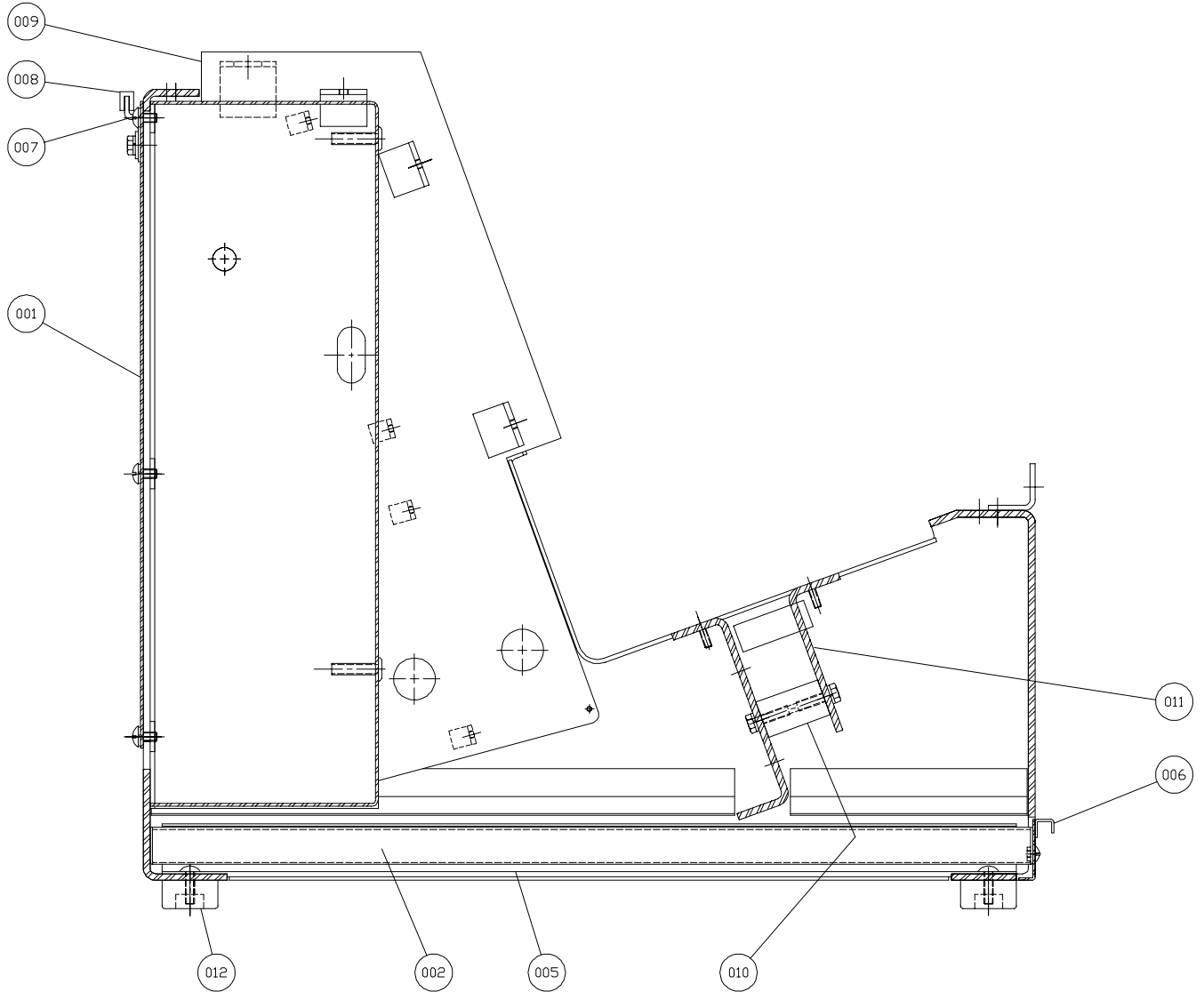

**MAIN FRAME PARTS LIST**

<u>ITEM NO.</u>	<u>PART DESCRIPTION</u>	<u>PART NUMBER</u>
001	Cover-Electrical	2003-0021
002	Track-Crumb Tray	2003-0038
005	Tray-Crumb	2003-0037
006	Plate-Face	2003-0003
009	Frame-Main	2003-0001
010	Spacer-Angle	2003-0034
011	Angle-Table Support	2003-0011-1
012	Bumper-Rubber	5902-0021
*013	Stiffener	2003-0054-1

**\*Not shown on drawing**

Rev. 1/25/05

**BLADE & CLUTCH DRIVE ASSEMBLY**

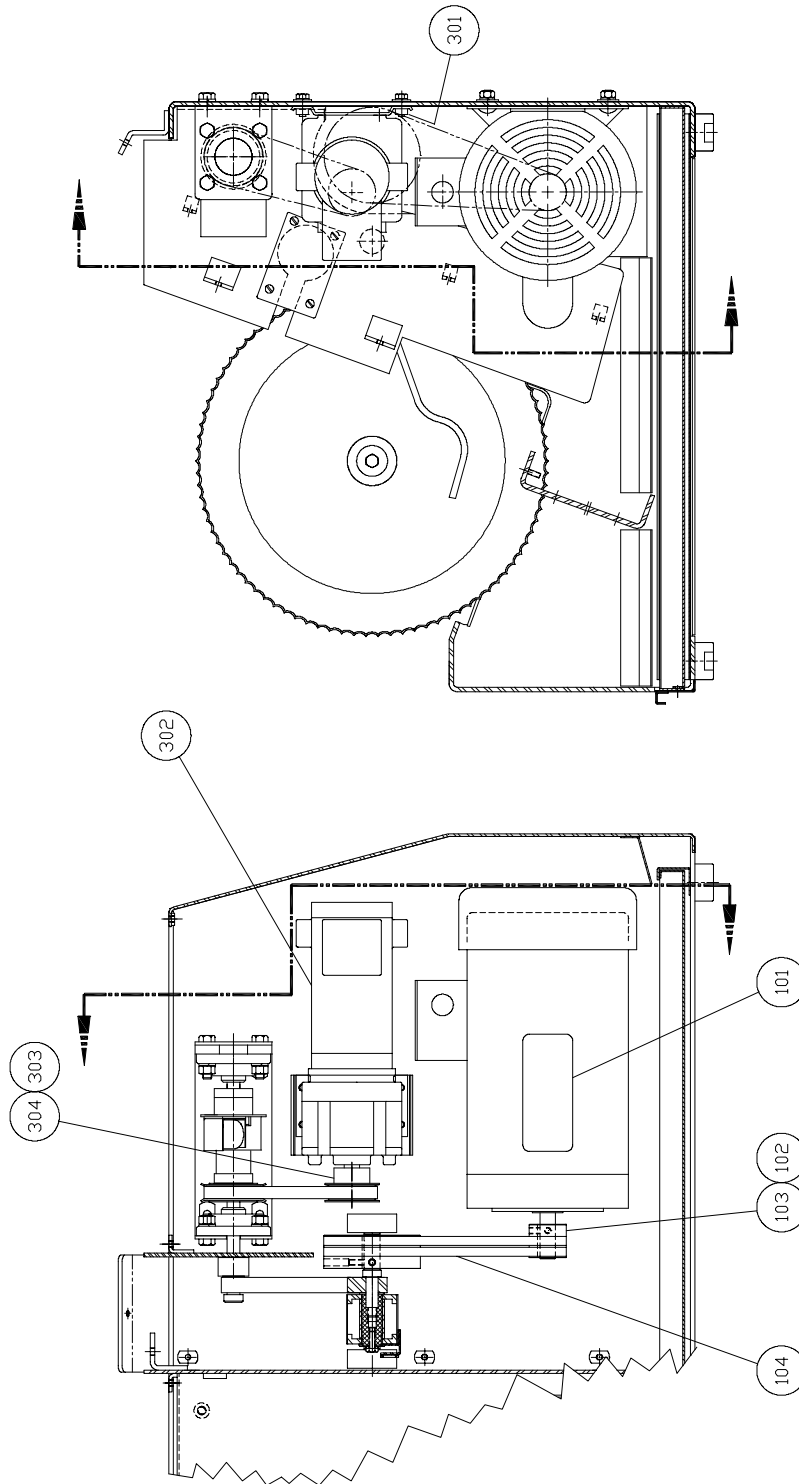

**BLADE & CLUTCH DRIVE PARTS LIST**

<u>ITEM NO.</u>	<u>PART DESCRIPTION</u>	<u>PART NUMBER</u>
101	Motor-Brake 3/4 HP	6301-5611
102	Screw-Socket Set	5842-6133
103	Sheave 3L, 2-Grooves 1.5 OD	2003-0070
104	Belt-V 3L230	5601-1033
301	Nutbar	2001-0015
302	Gearmotor 1/8 HP DC (115 VAC)	6310-0008
304	Pulley-Timing Belt	4495-2816-2001

**CUTOFF ARM ASSEMBLY**

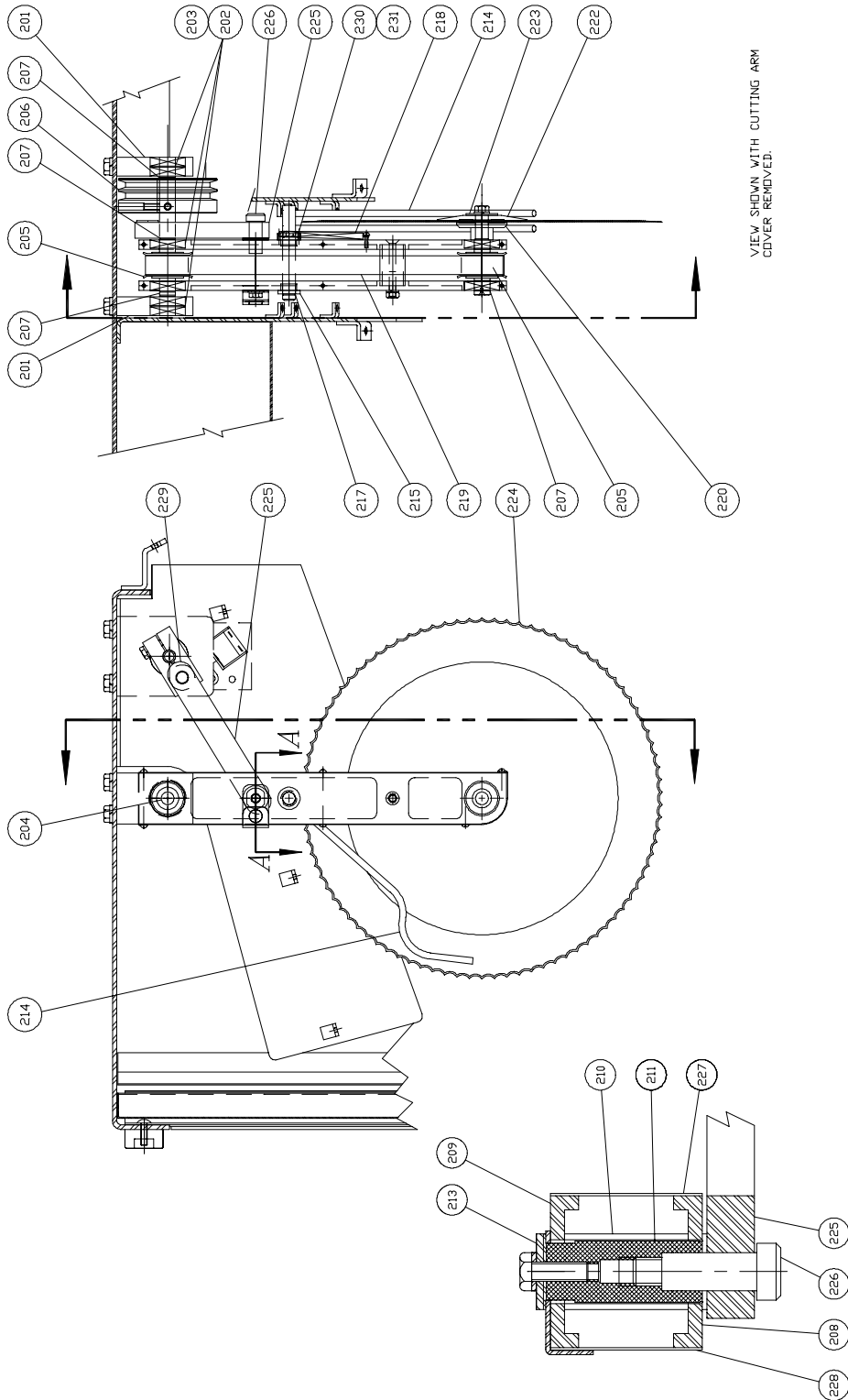

**CUTOFF ARM PARTS LIST**

<u>ITEM NO.</u>	<u>PART DESCRIPTION</u>	<u>PART NUMBER</u>
201	Block-Pivot Outside	2001-0041
202	Bearing-Ball	5250-0387
203	Ring-Retaining #N5000-137	5840-1026
204	Shaft-Drive	2001-0047-1
205	Pulley-Timing Belt	2003-0044
206	Sheave-3L, 2-Grooves 3.882 OD	2003-0071
207	Ring-Retaining #5100-62	5840-1128
208	Side-RH Arm	2003-0046-1
209	Side-LH Arm	2003-0047
210	Spacer-Aluminum Tube	2003-0050
211	Trunnion	2003-0052
213	Washer-Flat 9/32 x 1/8	5851-8126
214	Holddown	2003-0064
215	Bearing-Bronze Flange	5254-3190
217	Ring-Retaining #5100-50	5840-1125
218	Spring-Extension	7021-4005
219	Belt-Timing 300L075	5601-3341
220	Spindle-Blade	2001-0072-101
222	Disk/Collar	2001-0073-001
223	Washer-Special	2001-0074
224	Knife-Scalloped	7107-7056
225	Rod-Connecting	2003-0027
226	Screw-Shoulder 1/2 X 1-1/4	5842-8545
227	Cover-Top	2003-0048
228	Cover-Bottom	2003-0049
229	Bearing-Bronze Thrust	5254-3507
230	Bushing-Stop	2003-0065
231	Pin-Coiled	5835-7625

**PUSHER WITH STEPPER ASSEMBLY**

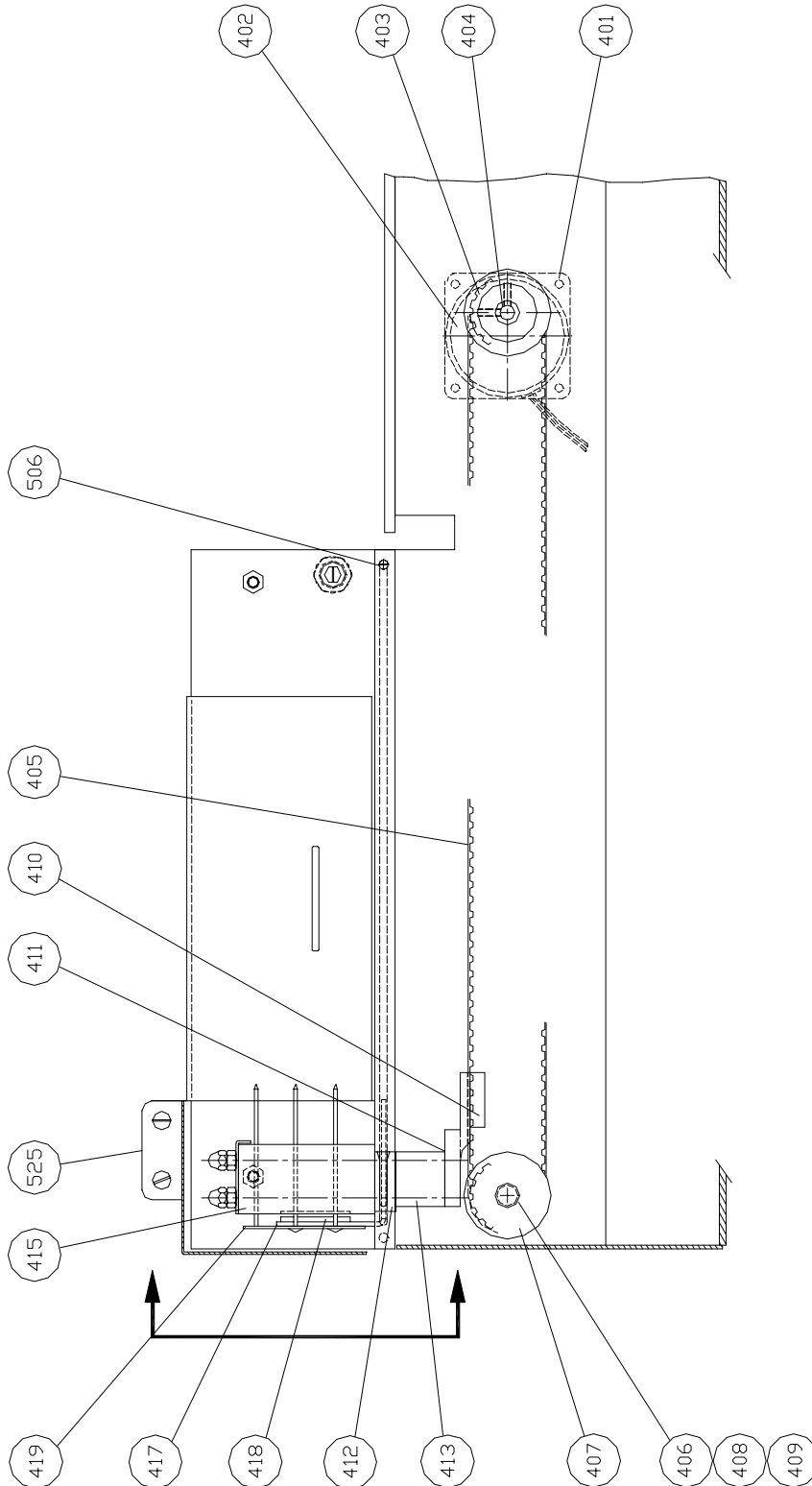

**PUSHER WITH STEPPER PARTS LIST**

<u>ITEM NO.</u>	<u>PART DESCRIPTION</u>	<u>PART NUMBER</u>
401	Nutbar-Motor	2001-0110
402	Motor Assy-Stepper	2003-0023
403	Gearhead-6:1 Ratio	5607-3070
404	Pulley-Timing Belt	2003-0062
405	Belt-Timing # 510L050	5601-3420
406	Spindle-Idler	2001-0051
407	Pulley-Idler Timing	2001-0050
408	Bearing-Ball	5250-0386
409	Ring-Retaining # N5000-112	5840-1020
410	Clamp-Belt	2001-0034
411	Hitch-Pusher	2003-0007
412	Block-Center Wear	2001-0046
413	Pad-Bottom Wear	2003-0010
415	Block-Pusher	2003-0005
416	Wiper Blade Assembly	2003-0009
417	Bracket-Pusher	2001-0035
418	Nutbar-Pusher	2001-0089
419	Plate-Pusher W/Pins	2003-0006

**TABLE & COVER ASSEMBLY**

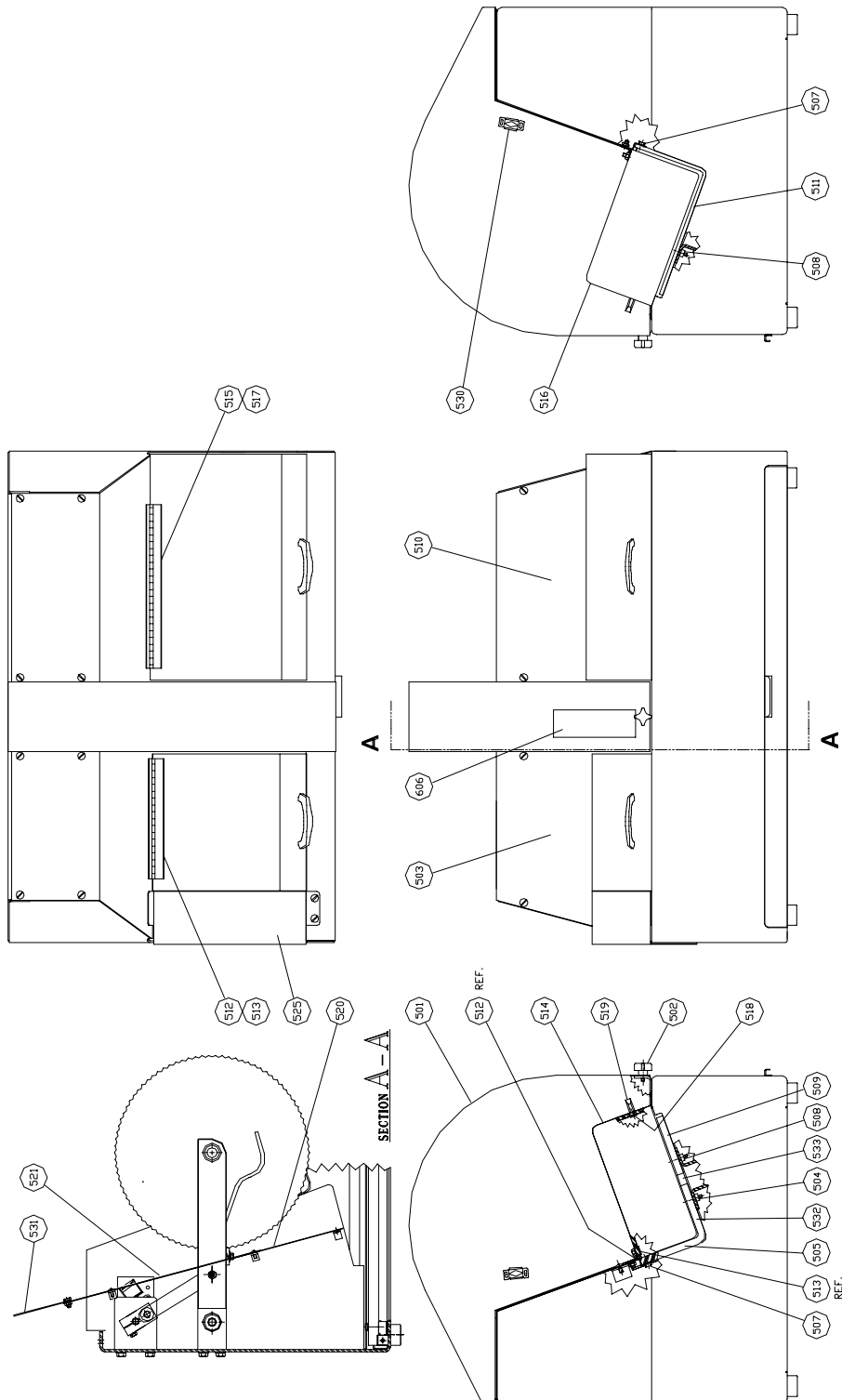
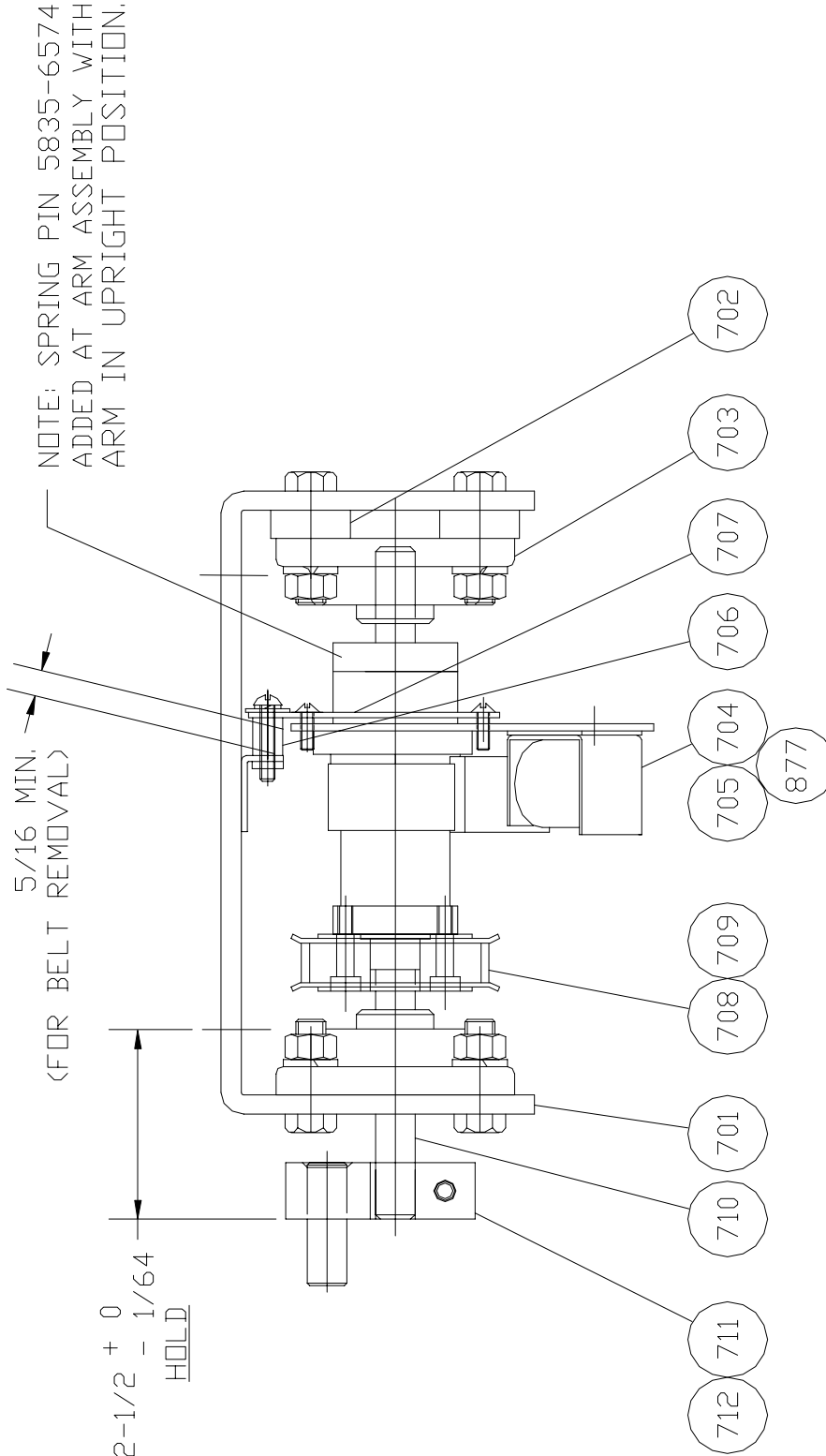

**TABLE & COVER PARTS LIST**

<b><u>ITEM NO.</u></b>	<b><u>PART DESCRIPTION</u></b>	<b><u>PART NUMBER</u></b>
501	Guard-Blade	2005-0014-001
502	Knob-Screw	4560-2508-1106
503	Panel-Infeed	2005-0009
504	Nutbar-Infeed	2001-0102-001
505	Table-Rear Adj. Infeed	2003-0013-001
506	Pin 1/4 Diameter X 3/4	4475-0516-075
507	Nut-Cage 1/4-20	5832-0425
508	Nutbar-Outfeed	2001-0103-001
509	Table-Front Adj. Infeed	2005-0048-1
510	Panel-Outfeed	2003-0017
511	Table-Rear Adj. Outfeed	2003-0014
512	Hinge—Infeed Cover	2001-0008
513	Strip-Hinge Backer (Infeed)	2001-0123
514	Cover-Infeed	2005-0010
515	Plate-Hinge Backer	2001-0009
516	Cover-Outfeed	2005-0011
517	Strip-Hinge Backer (Outfeed)	2003-0029
518	Strip-Handle Backer	2000-0087
519	Handle-Pull	5908-5100
520	Chute-Lower Crumb	2003-0030
521	Chute-Upper Crumb	2005-0012
525	Cover-Pusher	2003-0019
530	Catch-Magnetic W/Strike	5805-2503
532	Table-Bottom Adjustable (Infeed)	2005-0051-2
533	Spacer with Pin	2005-0061



**CLUTCH ASSEMBLY**



**CLUTCH ASSEMBLY PARTS LIST**

<u>ITEM NO.</u>	<u>PART DESCRIPTION</u>	<u>PART NUMBER</u>
701	Bracket-Clutch	2001-0016-1
702	Spacer	2001-0032
703	Bearing-Flange Ball	5251-3420
704	Clutch	5604-5257 
705	Cover-Clutch	5604-5518
706	Spacer-Anchor	2001-0017
707	Plate-Anchor	2001-0033
708	Pulley-Timing Belt	2001-0001
709	Belt-Timing # 165L050	5601-3450
710	Shaft-Drive	2001-0019
711	Crank	2003-0028
712	Key	4384-0404-075

**ELECTRICAL SUB-PANEL ASSEMBLY**

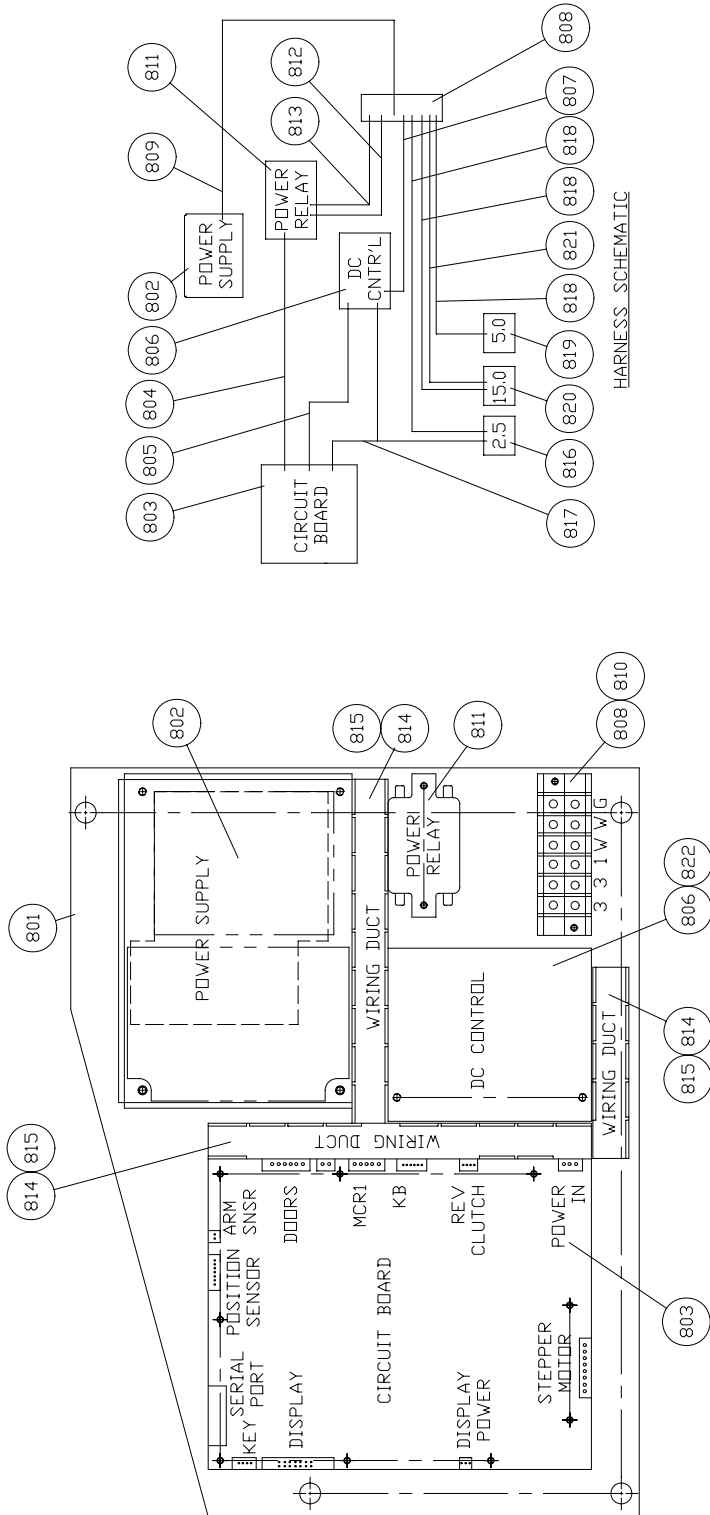

**ELECTRICAL SUB-PANEL PARTS LIST**

<u>ITEM NO.</u>	<u>PART DESCRIPTION</u>	<u>PART NUMBER</u>
801	Sub-panel	2005-0008
802	Power Supply-AC/DC	2005-0056K
*803	Circuit Board-Control (8 slice keys)	2005-0060-010
*803	Circuit Board-Control (6 slice keys)	2005-0060-011
804	Harness-Control to Relay	2005-0006
805	Harness-Wire	2005-0026
806	Control-DC Drive	6309-6000
807	Harness-Wire	2005-0020
808	Block-Terminal	5770-7350
809	Wire-Ground 10"	2005-0038
810	Jumper-Terminal Block	5767-8810
811	Relay-Power	5749-8010
812	Harness-Wire 4"	2005-0002
813	Harness-Wire 4-3/8"	2005-0005
814	Duct-Wiring	5766-3301
815	Cover-Wiring Duct	5766-3325
816	Breaker-Circuit 2.5A	5757-4125
817	Harness-Control to 2.5A Breaker	2005-0007
818	Harness-Wire 13"	2005-0018
819	Breaker-Circuit 5.0A	5757-4279
820	Breaker-Circuit 15.0A	5757-4358
821	Harness-Wire 12'	2005-0003
822	Resistor-Control	6309-6014

Revised 11-14-08

**ELECTRICS 1-60-115 ASSEMBLY**

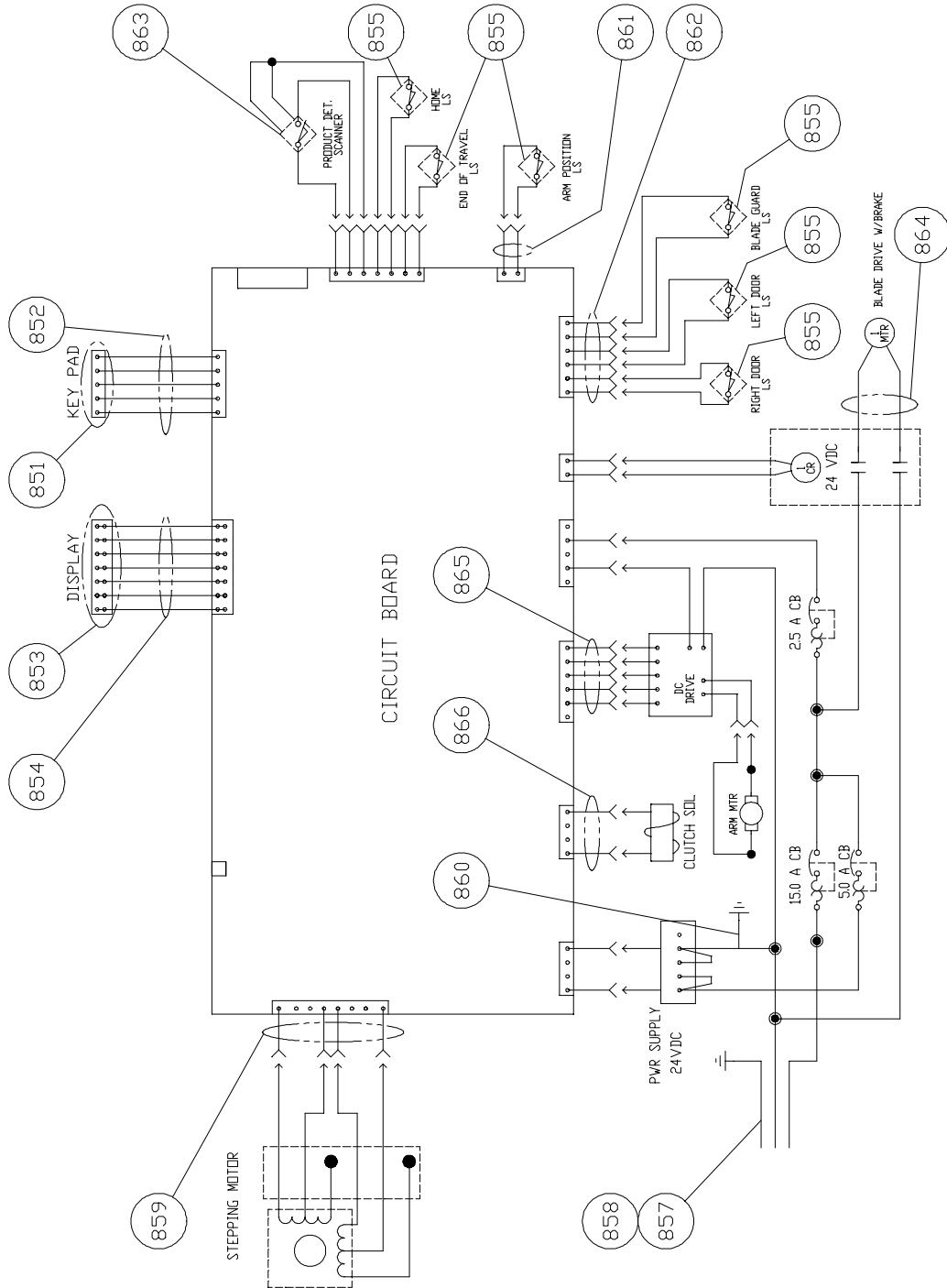

**ELECTRICS 1-60-115 PARTS LIST**

<u>ITEM NO.</u>	<u>PART DESCRIPTION</u>	<u>PART NUMBER</u>
851	Board-Key Pad	5765-3843
852	Harness-Wire 48"	2005-0023
853	Display-Vacuum	2005-0057
854	Cable-Display	2005-0032
855	Switch-Reed	5757-7540
857	Cord-Power 115V	2005-0017
858	Bushing-Strain Relief	5765-1079
859	Harness-Wire (Stepper)	2005-0031
860	Wire-Ground 6"	2005-0037
861	Harness-Wire 18" (Arm Sensor)	2005-0001
862	Harness-Wire (Door Switches)	2005-0024
863	Eye-Photo	2005-0027
864	Harness-Wire (Drive Motor)	2005-0028
865	Harness-Wire (DC Motor)	2005-0029
866	Harness-Wire (Clutch)	2005-0030
867*	Grommet	5767-1208

\* Not Shown Drawing

---

## WARRANTY

### PARTS

Oliver Products Company (Oliver) warrants that if any part of the equipment (other than a part not manufactured by Oliver) proves to be defective (as defined below) within one year after shipment, and if Buyer returns the defective part to Oliver within one year, Freight Prepaid to Oliver's plant in Grand Rapids, MI, then Oliver, shall, at Oliver's option, either repair or replace the defective part, at Oliver's expense.

### LABOR

Oliver further warrants that equipment properly installed in accordance with our special instructions, which proves to be defective in material or workmanship under normal use within one (1) year from installation or one (1) year and three (3) months from actual shipment date, whichever date comes first, will be repaired by Oliver or an Oliver Authorized Service Dealer, in accordance with Oliver's published Service Schedule.

For purposes of this warranty, a defective part or defective equipment is a part or equipment which is found by Oliver to have been defective in materials workmanship, if the defect materially impairs the value of the equipment to Buyer. Oliver has no obligation as to parts or components not manufactured by Oliver, but Oliver assigns to Buyer any warranties made to Oliver by the manufacturer thereof.

This warranty **does not** apply to:

1. Damage caused by shipping or accident.
2. Damage resulting from improper installation or alteration.
3. Equipment misused, abused, altered, not maintained on a regular basis, operated carelessly, or used in abnormal conditions.
4. Equipment used in conjunction with products of other manufacturers unless such use is approved by Oliver Products in writing.
5. Periodic maintenance of equipment, including but not limited to lubrication, replacement of wear items, and other adjustments required due to installation, set up, or normal wear.
6. Losses or damage resulting from malfunction.

The foregoing warranty is in lieu of all other warranties expressed or implied AND OLIVER MAKES NO WARRANTY OF MERCHANTABILITY OR FITNESS FOR PURPOSE REGARDING THE EQUIPMENT COVERED BY THIS WARRANTY. Oliver neither assumes nor authorizes any person to assume for it any other obligations or liability in connection with said equipment. OLIVER SHALL NOT BE LIABLE FOR LOSS OF TIME, INCONVENIENCE, COMMERCIAL LOSS, INCIDENTAL OR CONSEQUENTIAL DAMAGES.

## WARRANTY PROCEDURE

1. If a problem should occur, either the dealer or the end user must contact the Customer Service Department and explain the problem.
2. The Customer Service Manager will determine if the warranty will apply to this particular problem.
3. If the Customer Service Manager approves, a Work Authorization Number will be generated, and the appropriate service agency will perform the service.
4. The service dealer will then complete an invoice and send it to the Customer Service Department at Oliver Products Company.
5. The Customer Service Manager of Oliver Products Company will review the invoice and returned parts, if applicable, and approve for payment.

## RETURNED PARTS POLICY

This policy applies to all parts returned to the factory whether for warranted credit, replacement, repair or re-stocking.

Oliver Products Company requires that the customer obtain a Return Material Authorization (RMA) number before returning any part. This number should appear on the shipping label and inside the shipping carton as well. All parts are to be returned prepaid. Following this procedure will insure prompt handling of all returned parts.

To obtain an RMA number contact the Repair Parts Department toll free at (800) 253-3893.

Parts returned for re-stocking are subject to a **RE-STOCKING CHARGE**.

Thank you for your cooperation,

Repair Parts Manager  
Oliver Products Company