



Grand Rapids, Michigan, U.S.A. 49504-5298

USER'S OPERATING AND INSTRUCTION MANUAL

MODEL 1179

BAGGER



1179 BAGGER

1179 OPERATORS MANUAL

INDEX

I. GENERAL

Safety Instructions	1179S20010
---------------------------	------------

II. OPERATION

Operation Instructions	1179S20000
1179 Funnel Replacement	1179S20001

III. REPLACEMENT PARTS SECTION

1179 Parts List	1179S20002
1179 Exploded Parts Drawing	1179S20003
Floor Stand Parts Drawing and List	1279S20003

IV. BAG PURCHASING

Bag Specification Instructions	1279S20004
--------------------------------------	------------

V. WARRANTY SECTION

Warranty	GEN040225
Warranty Procedure	GEN040226
Returned Parts Policy	GEN040227

BAGGER SAFETY INSTRUCTIONS

OLIVER PRODUCTS COMPANY

Every effort has been made by Oliver Products Company to provide you with a safe machine. It is essential, however, that machine operators and maintenance personnel observe the following safety instructions.

1. Before attempting to operate your bagger, read the Operating Instruction portion of this Manual.
2. Make sure that the bagger is only connected to a properly grounded electrical supply source.
3. Make sure the machine has been disconnected from the power supply before cleaning or servicing.
4. Always keep hands away from moving parts.
5. "WARNING," when adjusting the height of the "optional" bagger table, you must support the table to prevent accidental collapse. Adjust one leg at a time.

OPERATING INSTRUCTIONS FOR 1179 BAGGER

SPECIFICATIONS

MACHINE DIMENSIONS: 13" WIDE X 41" LONG X 13" HIGH
BAG WIDTH: 4 TO 13" (WICKETED BAGS ONLY)
BAG LENGTH: AS REQUIRED
STANDARD COLOR: WHITE
ELECTRICAL SERVICE: 115 VOLTS*, 50 OR 60 HZ, 1 ph, 1.02 AMP.
*(230 VOLTS, .51 AMP. AVAILABLE)

ACCESSORIES

- SPECIAL HEIGHT FUNNELS
- EXTRA LENGTH BAG TRAY
- BAG SUPPORT FOR TRAY
- TILT TRAY
- FLOOR STAND

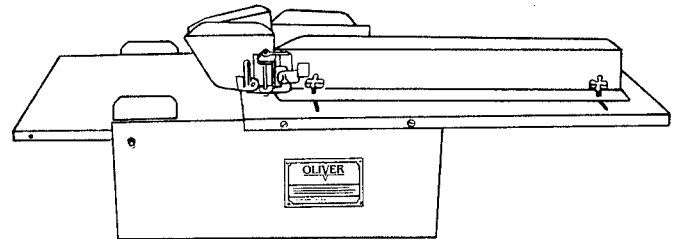

GENERAL:

Always turn your bagger off and disconnect it from the power supply before cleaning or making adjustments. The bagger must be adjusted for each change in product width and height. Bag size is affected by height, width and length of your product. The following sections will aid you in adjusting your machine, in operation, in bag specification and in changing the funnels on your machine should a special funnel be required.

ADJUSTMENTS:

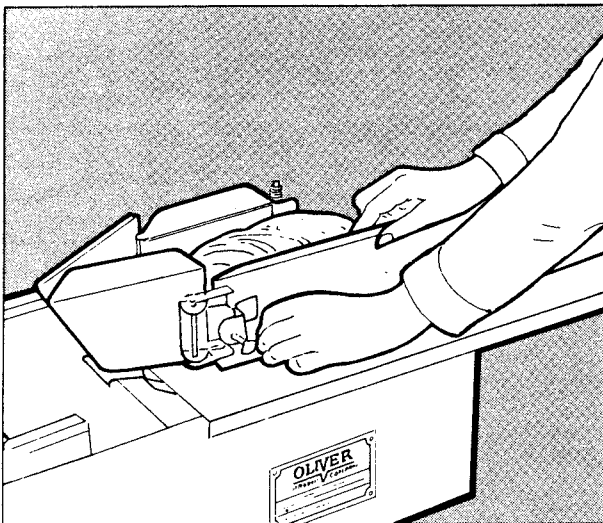

1. Center the product on the bagger and move the side guides into the product. When satisfied, tighten the knobs to maintain this position.

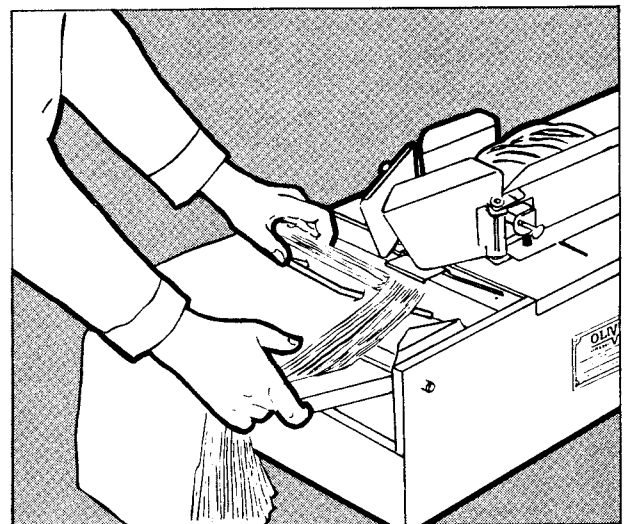

2. Wicketed bags must be used on your bagger. Place the wicket as shown with the wicket legs down and past the end of the bag tray.

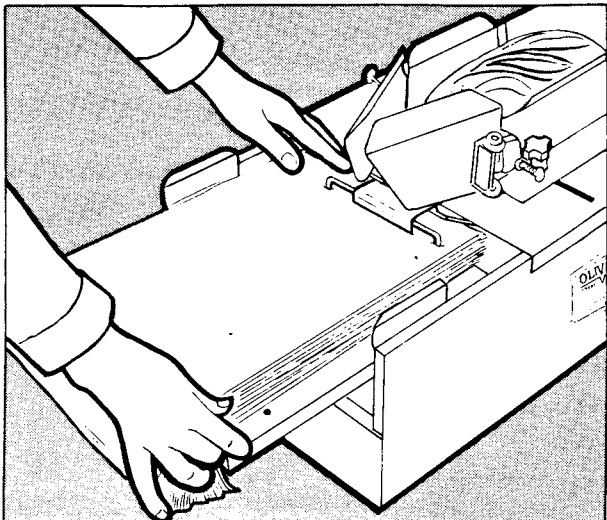

3. Secure the wicket behind the lip as shown.

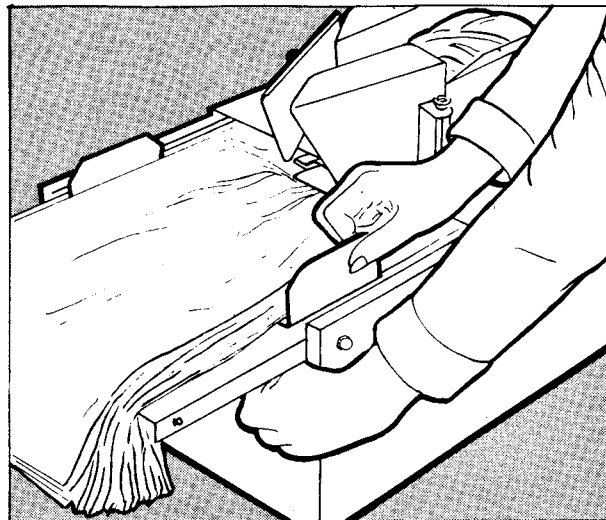

4. Adjust bag locators so as to center the bags on the machine.

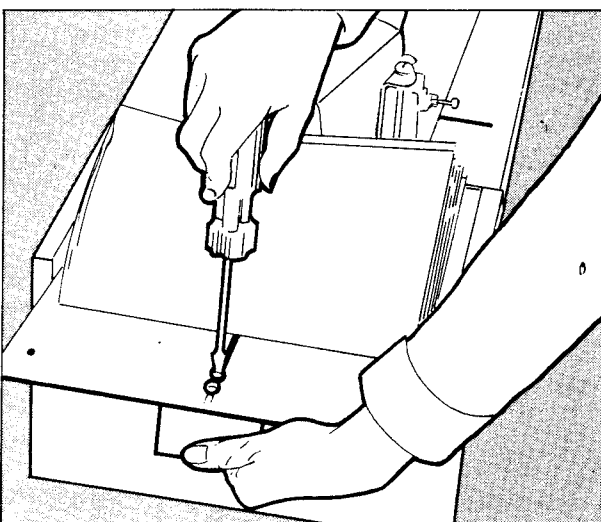

5. Adjust the weight so that it exerts enough force on the wicket to keep it from slipping out from under the lip.

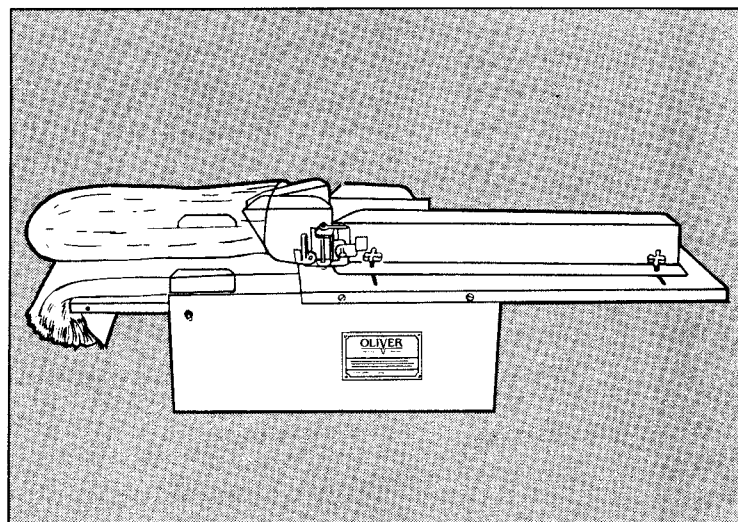

6. You are now ready to begin bagging. Reconnect the bagger to the power supply. Turn the bagger on. The first bag should fill with air and become ready for loading. Check funnel entry for adequate clearance.

OPERATION:

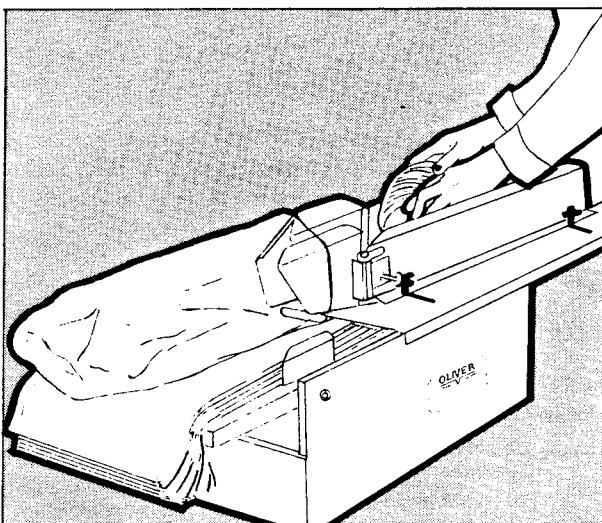

7. The operator should grasp the product as shown, and slide it into the bagger...

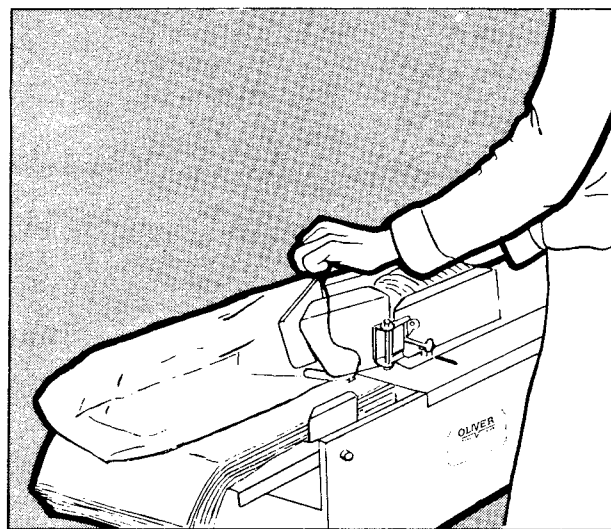

8. ...slide the product into the funnels. In certain cases it may help to hold the bag on its top edge as shown.

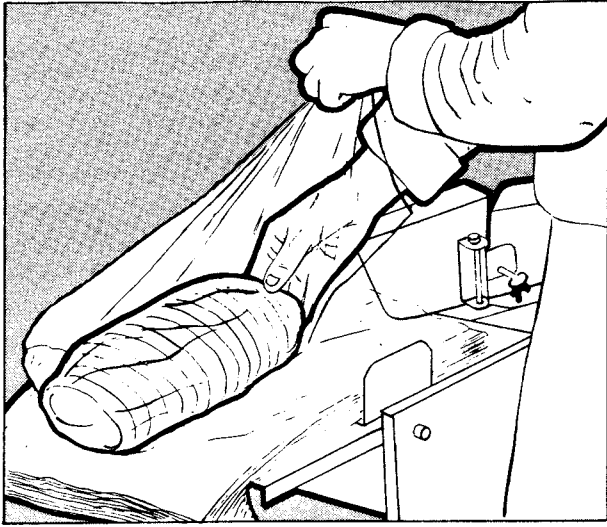

9. Push the product through the funnels and into the bag; continue pushing with one motion until the filled bag rips from the wicket. Steps 7-9 should be performed in one motion. The bag may now be closed.

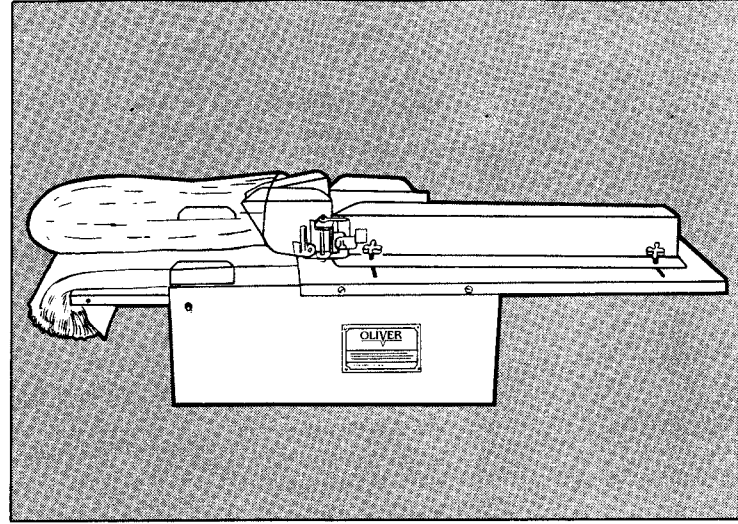

10. The next bag should fill with air, waiting for the next loading operation.

OPTIONAL OR SPECIAL FUNNELS:

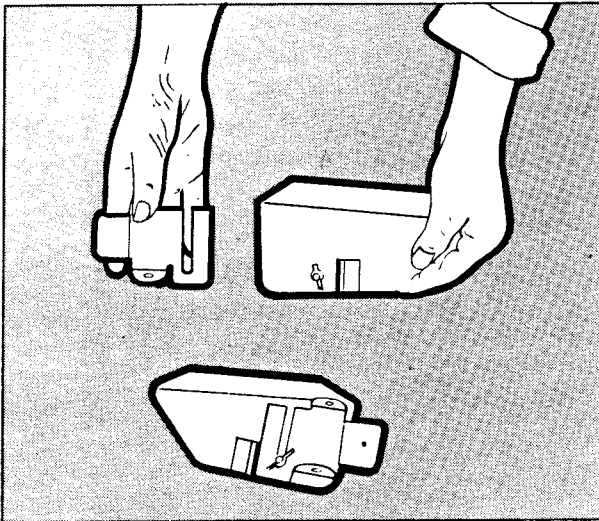

The adjustable funnels provided with your OLIVER bagger will work on a wide range of product shapes and sizes. Still, occasions may arise where a special funnel may be required.

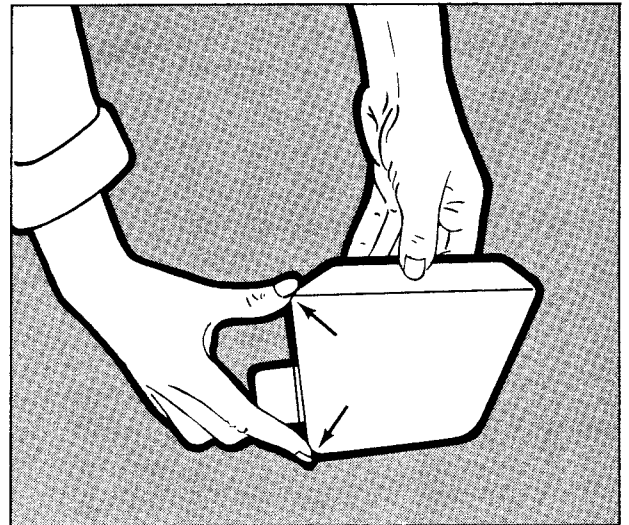

Shorter, taller or specially shaped funnels may be purchased at additional cost, from OLIVER PRODUCTS COMPANY. When asking for a special height funnel specify the dimension shown above when ordering.

NOTE:

Funnel height as well as product height and width will effect the bag width. If the funnels can not open fully into the bag, your bag may be too small, or your funnels may be too high.

1179 FUNNEL REPLACEMENT

In cases where either a special height or one-piece funnel is needed it becomes necessary to remove and replace the funnels on your bagger. Start by removing the side guide assemblies from the machine. The funnels which are attached to the side guides, can then be replaced by following the steps shown below.

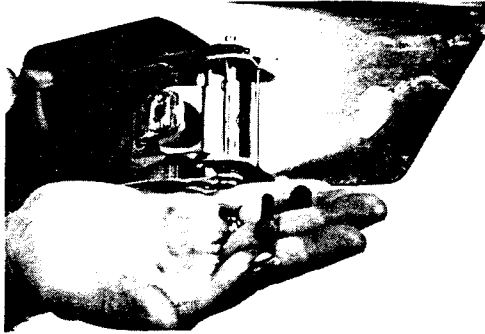

1. Remove the rubber stop and stop screw.

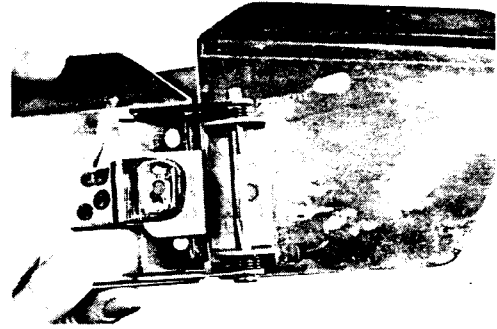

2. Note the position of the springs, bearings and pin. Be sure to replace them to this same location.

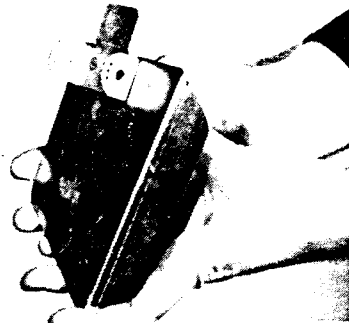

3. The three holes in the funnel allow for some spring adjustment, if required. Generally the center hole is used. Note which hole is used on your assemblies and try that hole first when re-assembling.

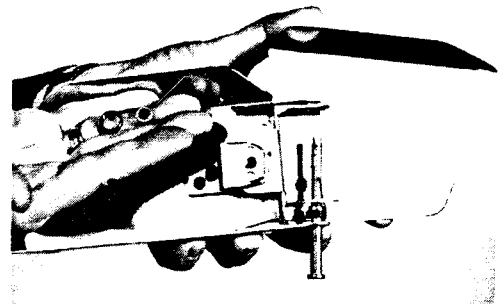

4. Remove the clevis pin after which the other components can also be removed. Remember to replace all springs, bearings, etc. to their original position.

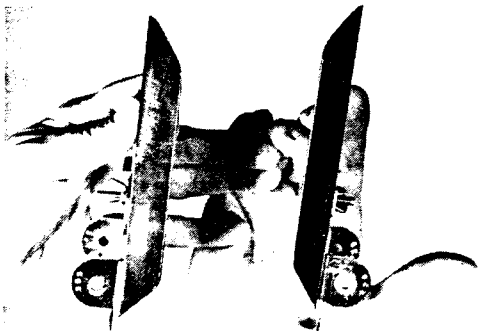

5. As the funnel parts are made opposite, make sure you have the correct part for the side you are working with.

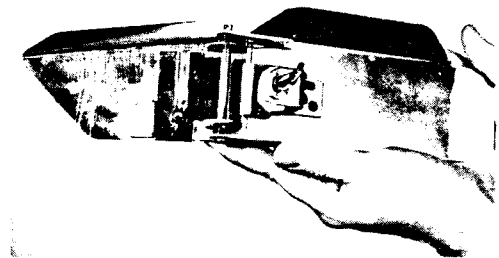

6. Re-assemble the spring, bearings, pin and stop screw to their original position. Check operation and increase or decrease spring tension if desired.

PARTS LISTS 1179 BAGGER

NOTE: Items not identified on this sheet or drawing are standard hardware items which may be purchased locally.

*Optional Items

<u>Item No.</u>	<u>Item Description</u>	<u>Part Number</u>
1	Tray-Bag	1079-0014-001
2	Locator-Bag	1079-0016
3	Case RH	1179-0001-0001
4	Table Infeed RH	1179-0002-0001
5	Weight	1179-0003
6	Lip	1179-0004
7	Stud-DE	4625-3508-135
8	Knob	4560-2508-1105
9	Cord 115 V.	5765-8300
*9	Cord 230 V.	1179-25011
10	Cord-Motor	1179-0019
11	Blower 1-50/60/115	6310-5020
*11	Blower 1-50/60-230	6310-5021
12	Guide-Short RH	1179-0005-0001
13	Guide-Long RH	1179-0006-0001
14	Cap-Neoprene	5106-8920
15	Brg. Brz 1/4x3/8x1/4	5254-0058
16	Knob	5911-7100
17	Pin-Clevis 1/4x3	5915-8060
18	Spring	7030-0001
19	Spring	7030-0003
20	Bracket-Stop RH	1179-0013-0001
21	Bracket-Stop LH	1179-0013-0002
22	Funnel-Adjustable RH 4-5-1/2"	1179-0014-0011
*22	Funnel-One Piece RH 4"	1179-0007-0001
*22	Funnel-One Piece RH 3"	1179-0007-0011
23	Funnel-Adjustable LH 4-5-1/2"	1179-0014-0012
*23	Funnel-One Piece LH 4"	1179-0007-0002
*23	Funnel-One Piece LH 3"	1179-0007-0012
24	Nameplate -Caution	6400-3006
25	Bolt-Carriage 1/4-20 x 1-1/2	5804-1706
26	Nut- Acorn 1/4-20	5832-0590
*27	Extension-Bag Tray	1079-0020-001
*28	Nut-Bar	4460-1008-1001
*29	Knob	5911-7014
*30	Support-Bag	1079-0021-001
31	Foot-Rubber	5902-0011
*32	Tilt Tray	1079-0024
*33	Shaft	4565-0108-0141
*34	Set Collar	5806-7004
*35	Bumper-Foot	5902-0011
*36	Knob	5911-7024
37	Strain Relief	5765-1080
38	Enclosure Switch	5764-8070
39	Switch	5758-0002

(Rev. 1-04-06)

1179S20002

OLIVER MODEL 1179 BAGGER

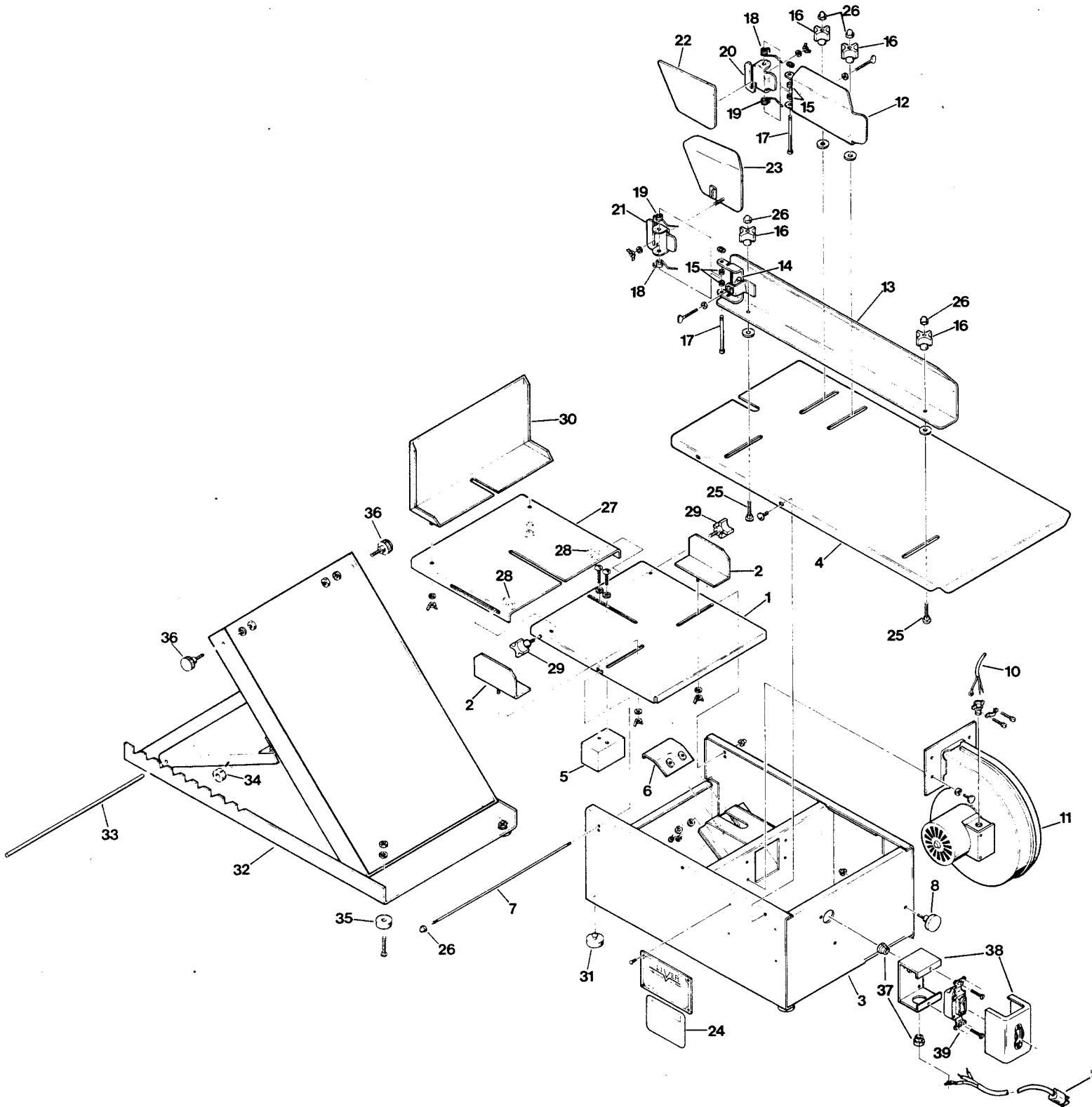

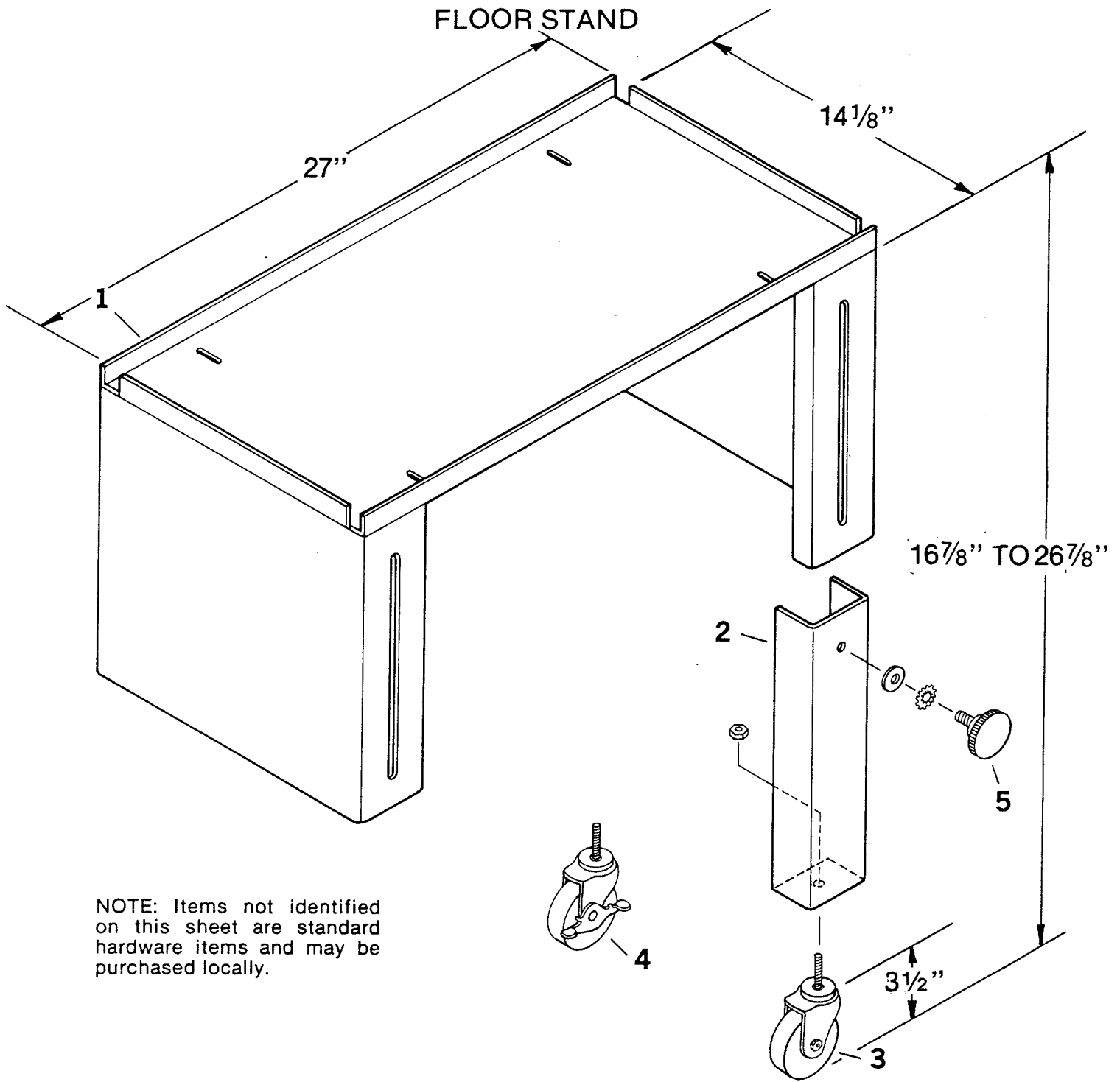

NOTE: Items not identified on this sheet are standard hardware items and may be purchased locally.

PARTS LIST:

			Quantity
1.	FRAME-FLOOR STAND	1079-0025	1
2.	LEG FLOOR STAND	1079-0026	4
3.	CASTER 3"	5902-2358	2
4.	CASTER 3" WITH BRAKE	5902-2359	2
5.	KNOB.....	5911-7027	4

BAG SPECIFICATION FOR OLIVER BAGGERS

BASIC BAGS

Most applications using the OLIVER bagger will be for either polyethylene or polypropylene bags. These bags must be of an extended lip design and mounted on a wicket, ideally about 250 bags per wicket. The bag can be purchased in different constructions as shown below.

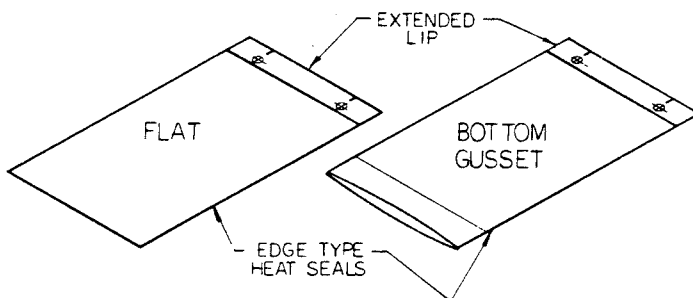

As other bags of either different construction or different materials can be purchased, we would suggest that if you desire to use one of these bags that your best course of action would be to obtain sample bags and to try them, as this would give you the best and most reliable answer to their acceptability.

SIZE SELECTION

The next thing you must determine is the bag size needed for your product. It is important to state here that the looser the fit between the product and the bag the easier it will be to insert the product, thereby increasing the speed of packaging. Conversely a tighter fit will generally result in a better looking package, but slower and more difficult packaging.

What follows is only "a rule of thumb" formula, and before placing an order with the bag manufacturer, sample bags should be tested for their acceptability. As all bagging machines are a little different it also follows that the bag may differ for the same product run on different baggers.

Bag Width

The minimum width of the bag can be roughly determined by adding the width + height, or, (the circumference divided by two, on irregular shapes), and adding 1/2" to 1". A 13" wide bag is the maximum width which can be used on an OLIVER bagger.

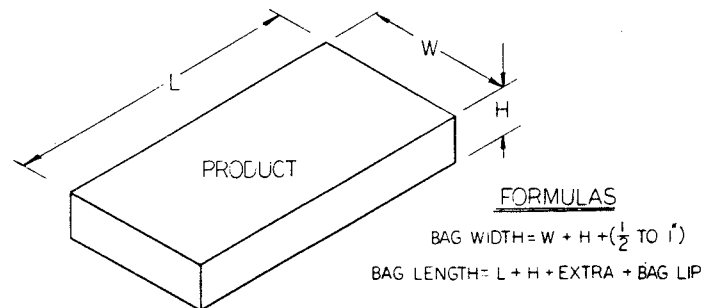

Bag Length

The length of the bag can roughly be determined by adding the length + height of the product to an extra amount which must be determined by the user of the bagger based on the method which will be employed to close the bag; tying, taping, trim sealing, etc. This may be one to three or more inches depending on the closing method chosen.

LIP & WICKET SIZES

As mentioned before you must use extended lip design, wicketed bags. In general, the lip should be about 1½" long with the center line of the wicket holes about 1" from the edge. Often there is a cut above the wicket holes to aid the bag in tearing from the wicket during loading.

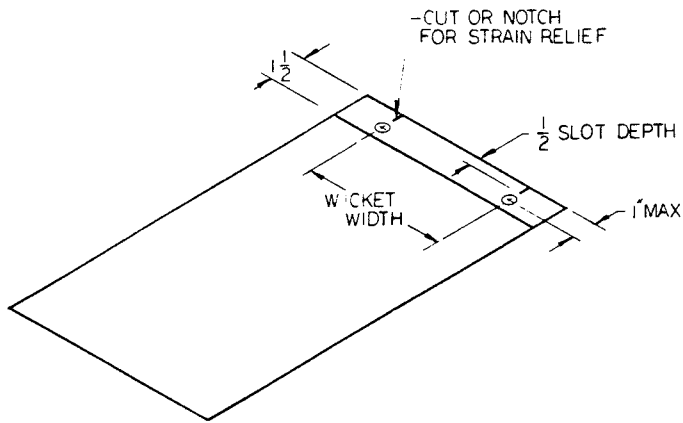

The width of the wicket should never be more than the maximum width of the product to be bagged, and should be centered on the bag. Note: If the wicket were wider than the product you would have to have a wider bag than normally required to handle the same size product.

BAG OPTIONS

We would like to mention a few of the bag options available, see the following illustration.

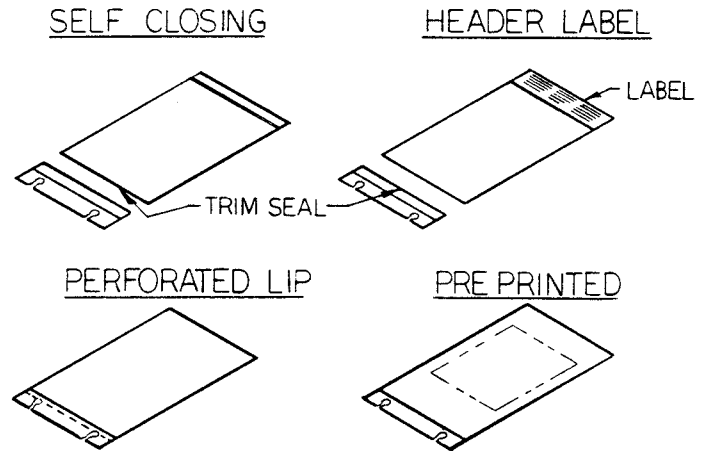

Consult your bag supplier for additional types and additional information on their availability for your application.



WARRANTY

PARTS

Oliver Packaging & Equipment Company (Oliver) warrants that if any part of the equipment (other than a part not manufactured by Oliver) proves to be defective (as defined below) within one year after shipment, and if Buyer returns the defective part to Oliver within one year, Freight Prepaid to Oliver's plant in Grand Rapids, MI, then Oliver, shall, at Oliver's option, either repair or replace the defective part, at Oliver's expense.

LABOR

Oliver further warrants that equipment properly installed in accordance with our special instructions, which proves to be defective in material or workmanship under normal use within one (1) year from installation or one (1) year and three (3) months from actual shipment date, whichever date comes first, will be repaired by Oliver or an Oliver Authorized Service Dealer, in accordance with Oliver's published Service Schedule.

For purposes of this warranty, a defective part or defective equipment is a part or equipment which is found by Oliver to have been defective in materials workmanship, if the defect materially impairs the value of the equipment to Buyer. Oliver has no obligation as to parts or components not manufactured by Oliver, but Oliver assigns to Buyer any warranties made to Oliver by the manufacturer thereof.

This warranty **does not** apply to:

1. Damage caused by shipping or accident.
2. Damage resulting from improper installation or alteration.
3. Equipment misused, abused, altered, not maintained on a regular basis, operated carelessly, or used in abnormal conditions.
4. Equipment used in conjunction with products of other manufacturers unless such use is approved by Oliver Products in writing.
5. Periodic maintenance of equipment, including but not limited to lubrication, replacement of wear items, and other adjustments required due to installation, set up, or normal wear.
6. Losses or damage resulting from malfunction.

The foregoing warranty is in lieu of all other warranties expressed or implied AND OLIVER MAKES NO WARRANTY OF MERCHANTABILITY OR FITNESS FOR PURPOSE REGARDING THE EQUIPMENT COVERED BY THIS WARRANTY. Oliver neither assumes nor authorizes any person to assume for it any other obligations or liability in connection with said equipment. OLIVER SHALL NOT BE LIABLE FOR LOSS OF TIME, INCONVENIENCE, COMMERCIAL LOSS, INCIDENTAL OR CONSEQUENTIAL DAMAGES.



Oliver Packaging & Equipment Company
511 Sixth Street NW • Grand Rapids, MI 49504

(800) 253-3893
www.oliverquality.com

WARRANTY PROCEDURE

1. If a problem should occur, either the dealer or the end user must contact the Parts and Service Department and explain the problem.
2. The Parts and Service Manager will determine if the warranty will apply to this particular problem.
3. If the Parts and Service Manager approves, a Work Authorization Number will be generated, and the appropriate service agency will perform the service.
4. The service dealer will then complete an invoice and send it to the Parts and Service Department at Oliver Products Company.
5. The Parts and Service Manager of Oliver Packaging and Equipment Company will review the invoice and returned parts, if applicable, and approve for payment.



Oliver Packaging & Equipment Company
511 Sixth Street NW • Grand Rapids, MI 49504

(800) 253-3893
www.oliverquality.com

RETURNED PARTS POLICY

This policy applies to all parts returned to the factory whether for warranted credit, replacement, repair or re-stocking.

Oliver Packaging and Equipment Company requires that the customer obtain a Return Material Authorization (RMA) number before returning any part. This number should appear on the shipping label and inside the shipping carton as well. All parts are to be returned prepaid. Following this procedure will insure prompt handling of all returned parts.

To obtain an RMA number contact the Repair Parts Department toll free at (800) 253-3893.

Parts returned for re-stocking are subject to a **RE-STOCKING CHARGE**.

Thank you for your cooperation,

Repair Parts Manager
Oliver Packaging and Equipment Company