

ITEM	DESCRIPTION	PART NUMB.	QTY.
1	WIRE BASKET	100589083	1
2	DOOR ASSY	181471016	1
3	LOCK HANDLE	103225001	1
4	LOCK	100581004	1
5	HINGE MOD. CAFSA CPE	300178001	2
6	HOLDER	100495001	1
7	GRILL	300459000	1
8	POWER CORD HARNESS	100388008	1
9	CASTER	100476016	4
10	DRYER FILTER	100773000	1
11	TEMPERATURE CONTROL	100398001	1
12	MABE COMPRESSOR C-BZN100L2GW	100397102	1
13	OVERLOAD RELAY	100516076	1
14	STARTING CAPACITOR	100517075	1
15	THERMAL PROTECTOR	100515071	1
16	MOTOR SYM BANG A12038V1MBT	100669040	1
17	HARNESS SUPPLEMENTS SYM BANG	300090000	1
18	GASKET FRAME	300484033	1

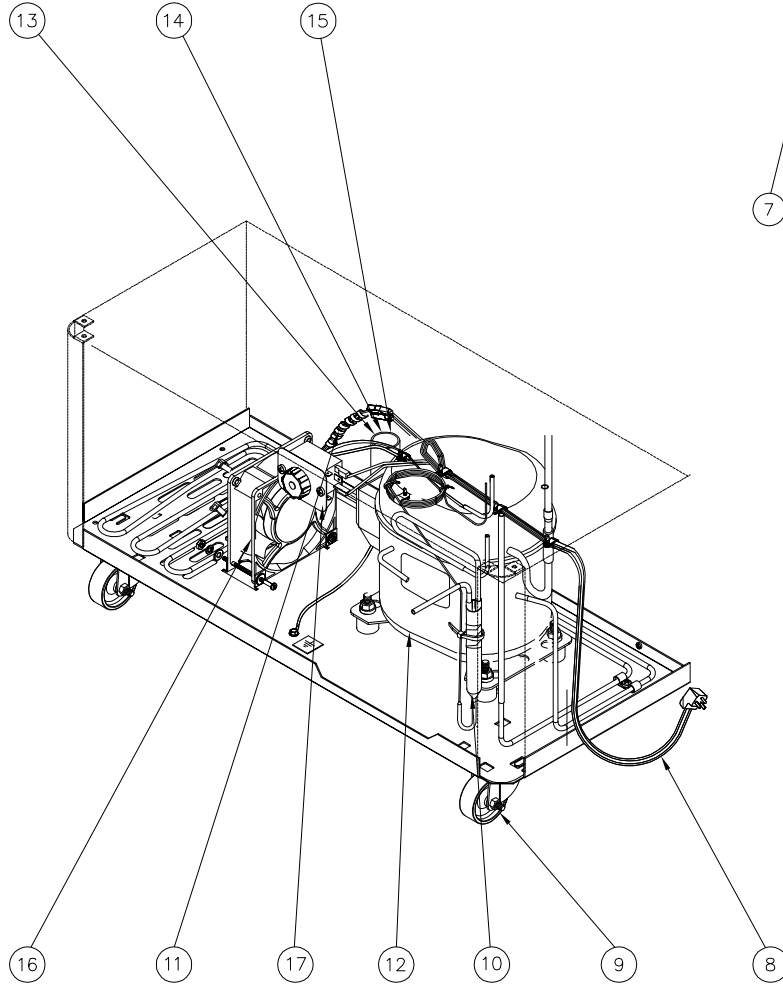
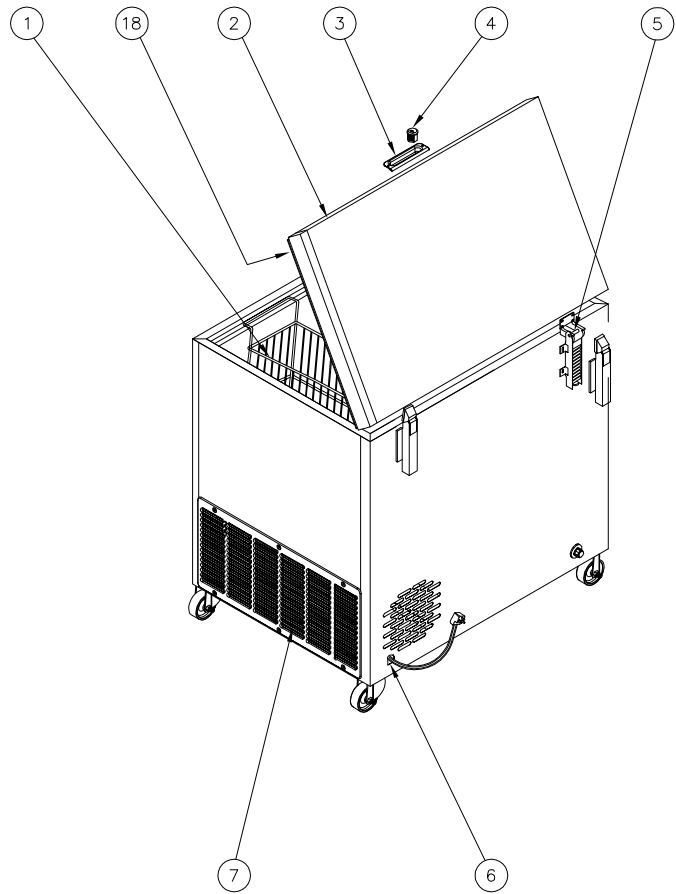

MODELO / MODEL:

PARTS LIST

" NCF - 28 "

ELABORO / DRAWN BY:  
S. MEZA

REVISO / CHECKED BY:  
J GONZALEZ

FECHA / DATE:  
OCT 30th 2014

HOJA / SHEET:  
1 - 1

No. DE DIBUJO / DRAWING No.  
181838032

REVISION  
A

**RC-EN-7.3-04**

NUM.	No PLANO	DESCRIPCION	CANT.
1	181318092	ENSAMBLE PUERTA ESPUMADA	1
2	300484033	MARCO GASKET	1
3	100438002	REMACHE POP ALUM AM-44 1/8"	17
4	100581004	CERRADURA SOUTHCO CM-2-2B10125B	1
5	103270008	LARGUERO SUJETADOR DEL GASKET	2
6	103271000	CABEZAL SUJETADOR DEL GASKET	2
7	100532000	TAPON P/ESPUMAR	1
8	100350008	CINTA C/ADHESIVO 2 CARAS 1/2 x 55 mts.	0.20 mts.
9	300332000	SUJETADOR DE TRINQUETE 27RT187500	2
10	103224002	TRINQUETE	1
11	103222000	BUJE TOPE PLASTICO	1
12	103225001	JALADERA PARA CERRADURA	1
13	102835010	TAPA DE PUERTA	1
14	100535013	ADHESIVO INSTANTANEO THREE BOND 1530C	0.212 CT

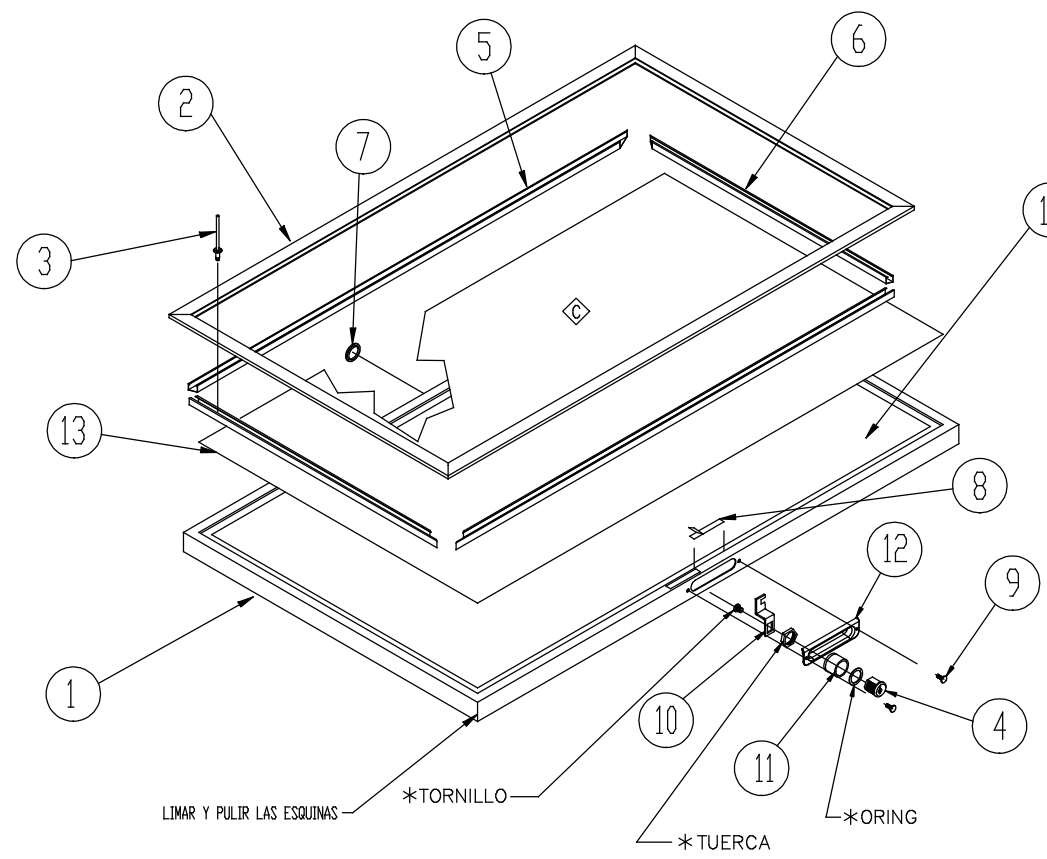
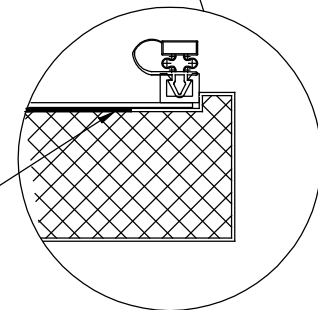
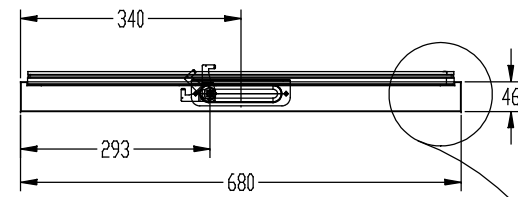

14 APLICAR EL ADHESIVO EN EL AREA ESPUMADA DE LA PUERTA

□ DIMENSIONES IMPORTANTES

**\* INCLUIDOS CON LA CERRADURA SOUTHCO**

REF. NCF-28

◊ SE CANCELA 103272009 ◊ SE ACTUALIZA ENSAMBLE ◊ CAMBIA CANTERA 1 ◊ SE CANCELA 103273009		1445
DESCRIPCION		AVISO No
TOLERANCIAS NO ESPECIFICADAS ANGULARES ± - LINEALES ± 1		<b>OJEDA</b> REFRIGERACION CANELA 79 A Y B GRANAS MEXICO TEL: 5657-44-22
ACOT: mm ("")	ESC: SIN	
DIBUJO O ACTUALIZO: SOTERO MEZA		MATERIAL : VER DESPIECE
REVISO : J.RIVAS		FECHA DE ACTUALIZACION: JULIO/8/2014
RUTA DE ACCESO: P:\AFAP\MODIFICA		ACABADO : VER DESPIECE
		No DE DIBUJO : 181471016
		ULTIMA REVISION C