

NEWCO ENTERPRISES

INSTALLATION and OPERATION MANUAL

For AKH SERIES BREWERS

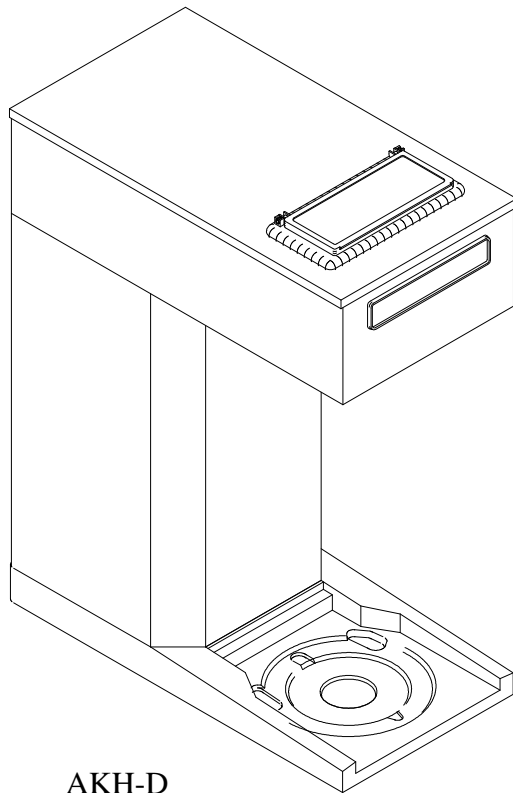

AKH-D

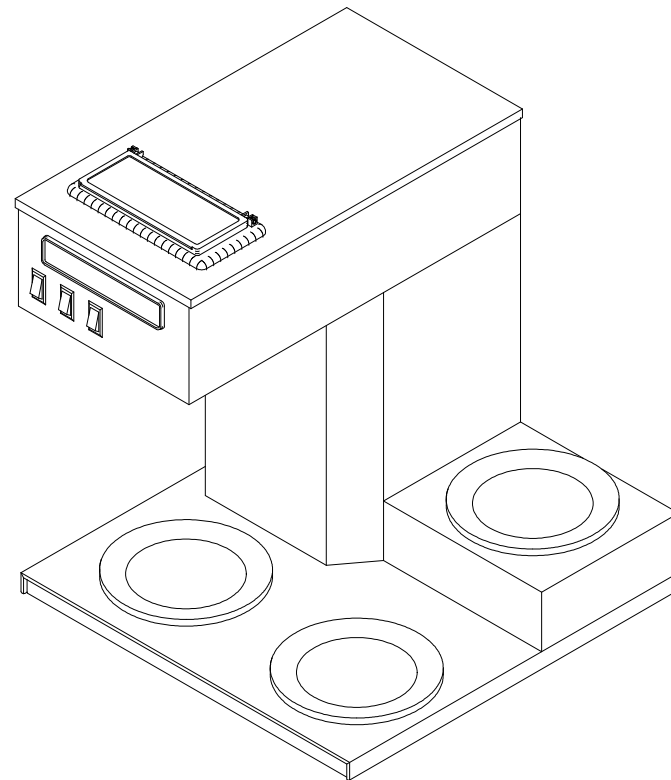

AKH-3

BREWER SPECIFICATIONS

Model	No of Warmers	Width	Length	Height*
AKH-1	1	8-1/2"	16 3/8"	16 15/16
AKH-2	2	8-1/2"	16 3/8"	18 9/16
AKH-3	3	15-1/2"	16 3/8"	16 15/16
AKH-AP	N/A	8-1/2"	16 3/8"	22 15/16
AKH-D	N/A	8-1/2"	17 3/8"	21 3/16
AKH-LD	N/A	8-1/2"	17 3/8"	21-3/8
AKH-TC	N/A	8-1/2"	17 3/8"	17 5/8
AKH-TT	N/A	8-1/2"	17 3/8"	16 15/16

INSTALLATION INSTRUCTIONS

WARNING: - Read and follow installation instructions before plugging or wiring in machine to electrical circuit. Warranty will be void if machine is connected to any voltage other than that specified on the name plate.

- 1) Plug or wire brewer to appropriate voltage circuit as indicated on serial tag. For (AKH Thermal Model) Turn master switch, located on rear of brewer, to the ON position.
- 2) (AKH warmer model), make sure warmer switches are in the OFF position. Place one of the empty decanters on the warmer located below the brew basket. For (AKH thermo model) pump style airpots, remove the pump stem. Place the empty dispenser into position below the brewbasket
- 3) Raise the top evaporation cover and pour ONE decanter (on AKH warmer model) or pitcher (on AKH thermo model) of water through the pour-in grid into basin.
- 4) (AKH warmer model), Turn lower warmer/brew switch to the ON or BREW position to start brew cycle.
NOTE: Float assembly will prevent heat pump from activating if water is not present in the basin. This first pot will be a few ounces short due to some water retention in the system.
- 5) Machine is now ready to use and will yield a full pot on following brew cycles.

COFFEE PREPARATION PROCEDURES

- 1) Place the filter into brew basket.
- 2) Place the appropriate amount of ground coffee into the filter for the volume of coffee to be brewed.
- 3) Slide the brew basket into holder.
- 4) For warmer units:
Place empty decanter on warmer located directly under the brew basket
Turn corresponding warmer switch to ON position.
For airpots or other dispensers
Remove any non brew thru lids or pump stems
Place airpot under brew basket.
- 5) Raise the top evaporation cover and pour ONE decanter(warmer model) or pitcher(therm model) of COLD water through the pour in grid into the basin. Turn lower warmer / brew switch to the ON position to start the brew cycle. (AKH warmer model), Brew cycle may be canceled by turning the rocker switch back to the off position. (AKH thermo model), The brew cycle may be canceled by turning the master switch located on the rear of the brewer to the off position.
NOTE: Never pour hot water into the brewer. This brewer features a European style brewing system which heats only the water for coffee when you pour it into the brewer. This type of system does not have a tank to store hot water. Do not overfill unit by pouring in more than one decanter of water at a time.
- 6) Hot water will be delivered through the sprayhead. This distributes the hot water evenly over the coffee bed within the brew basket. The coffee brew will drain from the brew basket into the decanter below.
- 7) The unique thermal brew system takes a little longer to brew than tank systems, which allow the stored water to become stale, but the result is better tasting and hotter coffee.
- 8) (AKH warmer model) TURN OFF WARMERS WHEN NOT IN USE. Red light in switch indicates when warmer is ON.
- 9) To clean brew basket simply remove from brew rails and dump filter into waste basket. The brewing process, as described above, can now be started again.
- 10) To clean brew basket simply remove from brew rails and dump filter into waste basket. The brewing process, as described above, can now be started again.

INSTALLATION INSTRUCTIONS (CONTINUED)

If unit will not brew, check the following before calling for service:

Is it plugged in?

Is there water in the receiving pan? Water activates the float switch, allowing the unit to brew.

(Warmer model) Is the lower warmer / brew switch in the ON position?

(Thermal model) Is the Master switch located on the rear of the brewer in the on position?

WARRANTY

Newco coffee brewers are warranted against defects in workmanship or materials, under normal use, for 90 days from the date of purchase. Brewer parts are warranted against defect for 12 months from date of purchase.

Liability in all events is limited to the purchase price paid and liability under the aforesaid warranty is limited to replacing or repairing any part or parts which are defective in material or workmanship, and returned to our factory, shipping cost prepaid. No warranty expressed or implied, other than the aforesaid is made or authorized by Newco Enterprises, Inc.

Prompt disposition will be made if item proves to be defective, within warranty. Before returning any item, write or call Newco, or the dealer from whom the product was purchased, giving model number, serial number, and date of purchase, and describe the nature of the defect. If damage was incurred during transit to you, file claim with the carrier.

REPLACEMENT PARTS LIST

Electrical Components

100085 Switch, ON/OFF Rocker Light
110912 Float Switch
102421 Heat Pump 1475W, 120V
102422 Heat Pump 1575W, 120V
102423 Heat Pump 1275W, 120V
100187 Element, Warmer 100w 120V
102624 Thermostat, HI-Limit, Auto

Plumbing Components

110939 Receiving Pan & Float Assy
102164 Receiving Pan
101954 Silicon Tubing 3/8 ID x 5/8 OD x 13"
102658 Silicon Tubing 3/8 ID x 5/8 OD x 7"

Labels/Decals

100253 Decal, Caution (Red)
100254 Decal, Caution (Hot Surface)
110120 Label, Warning (Hot Liquids)

Hardware & Miscellaneous

100008 Plate Only, Warmer, Black
100010 Plate Assy, Warming, Black
100025 Gasket, Sprayhead
101924 Cover, Receiving Expansion
101925 Spray Head Tube Assy
101956 Screw, 4-40 x 1 1/4, PPHMS
102799 Rail, Brew, R.H.
102800 Rail, Brew, L.H.
110624 Pour-In Cover, Plastic
110625 Pour-in Grid and Cover
201173 Nut, Sprayhead 7/16-20
201210 Sprayhead, Diffuser

COMPONENT REPLACEMENT INSTRUCTIONS

CAUTION: DISCONNECT BREWER CORD FROM ELECTRICAL OUTLET BEFORE REMOVAL OF ANY PANEL OR REPLACEMENT OF ANY COMPONENT!

NOTE: IN CANADA REPAIRS ARE TO BE DONE BY CERTIFIED ELECTRICIAN OR BREWER MUST BE REINSPECTED TO MAINTAIN APPLICABLE CERTIFICATION

WIRING DIAGRAM - THERMO UNITS

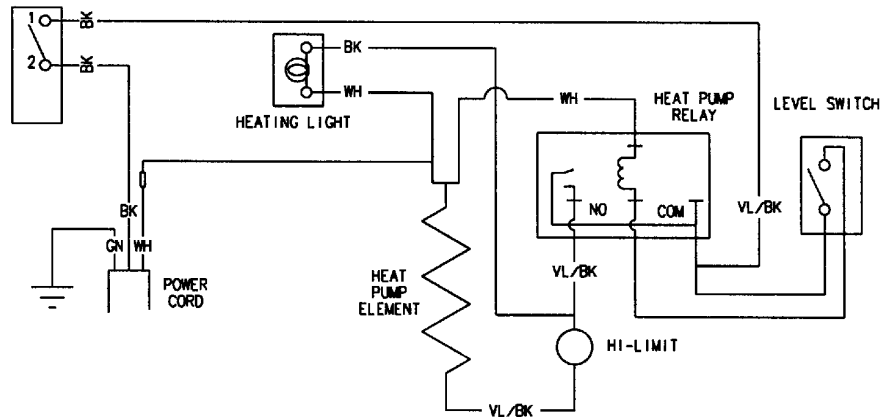

WIRING DIAGRAM - WARMER UNITS

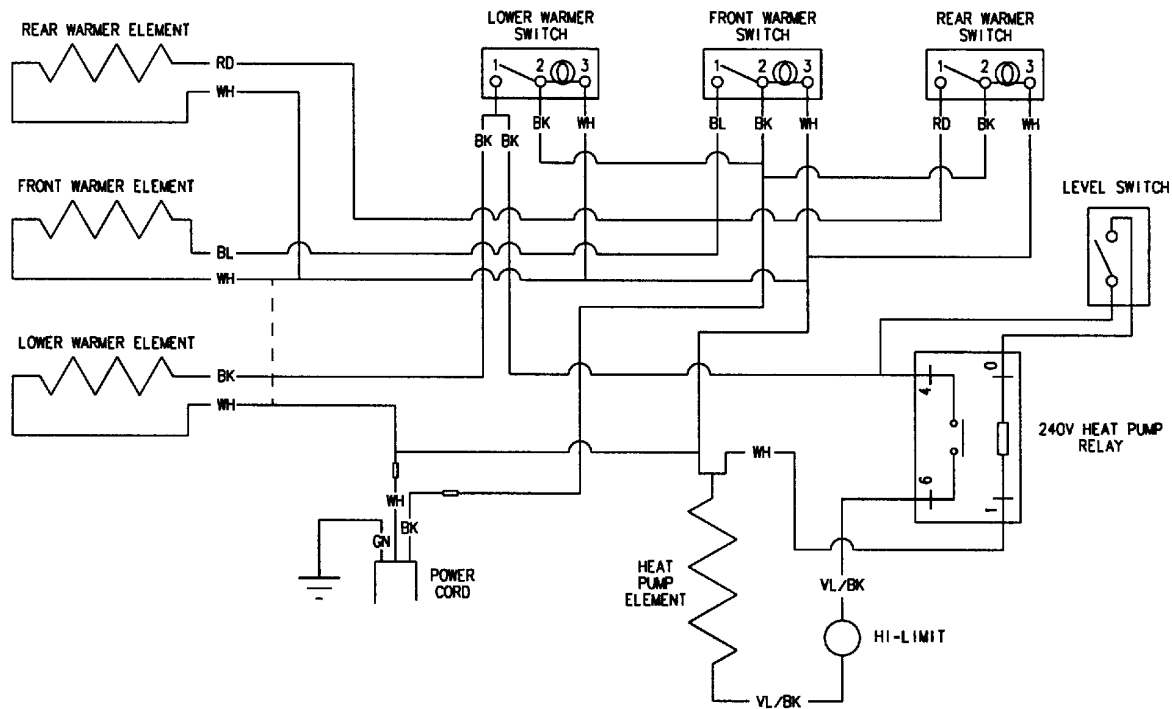

Newco Enterprises, Inc. * 1735 South River Rd. * P.O. Box 852 * St. Charles, MO 63303