

Mini Cappuccino

Instruction Manual

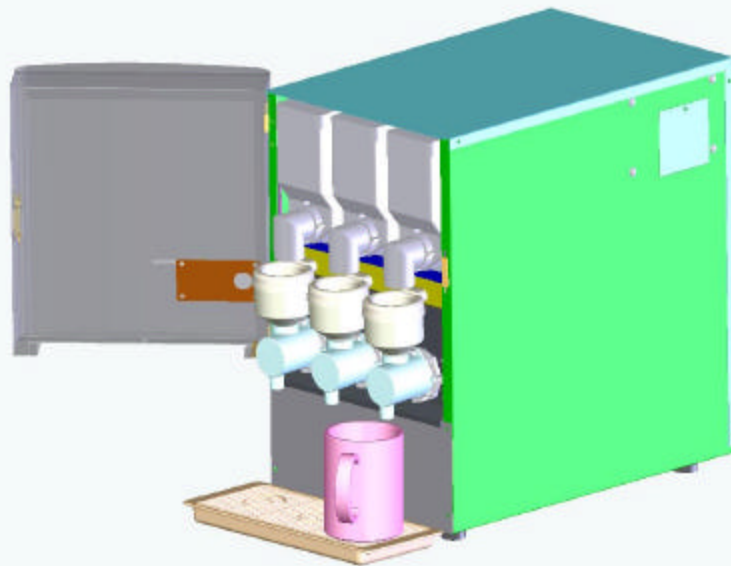

Features

- Under 17" Tall-Fits On Counter Under Cabinets
- Programmable Auto Dispense Feature
- Auto Rinse Feature
- Pump Technology for Precise Liquid Control

Date: 03 29 2004

Table of Contents

Specifications.....	Page 3
Unpacking and Start-up.....	Page 4
Troubleshooting.....	Page 6
Product Loading.....	Page 7
Machine Operation.....	Page 8
Cleaning and Sanitizing	Page 10
Service Procedures & Diagrams.....	Page 17
Wiring Diagram.....	Page 24

**Newco Enterprises, Inc.
3065 New Town Blvd
Saint Charles, MO 63301**

**Telephone 1-800-325-7867
Technical Support 1-800-556-3926
Fax 1-636-925-0029**

MODEL MINI CAP-3
771040 (2Lbs)
#781860 (3Lbs*)

SPECIFICATIONS:
 Shipping Weight: 39 Lbs
 Body Construction: 300 series Stainless
 Electrical: 120 VAC 15 A
 Heater: 1400 W
 Tank Capacity: 1 US Gallon
 Products: 3
 Canister Size: 2 Lbs *
 Dispense Mode: Portion or Manual

3 # Mach (17 1/2")
 20 1/8"
 + 4" Legs
 24 1/8"

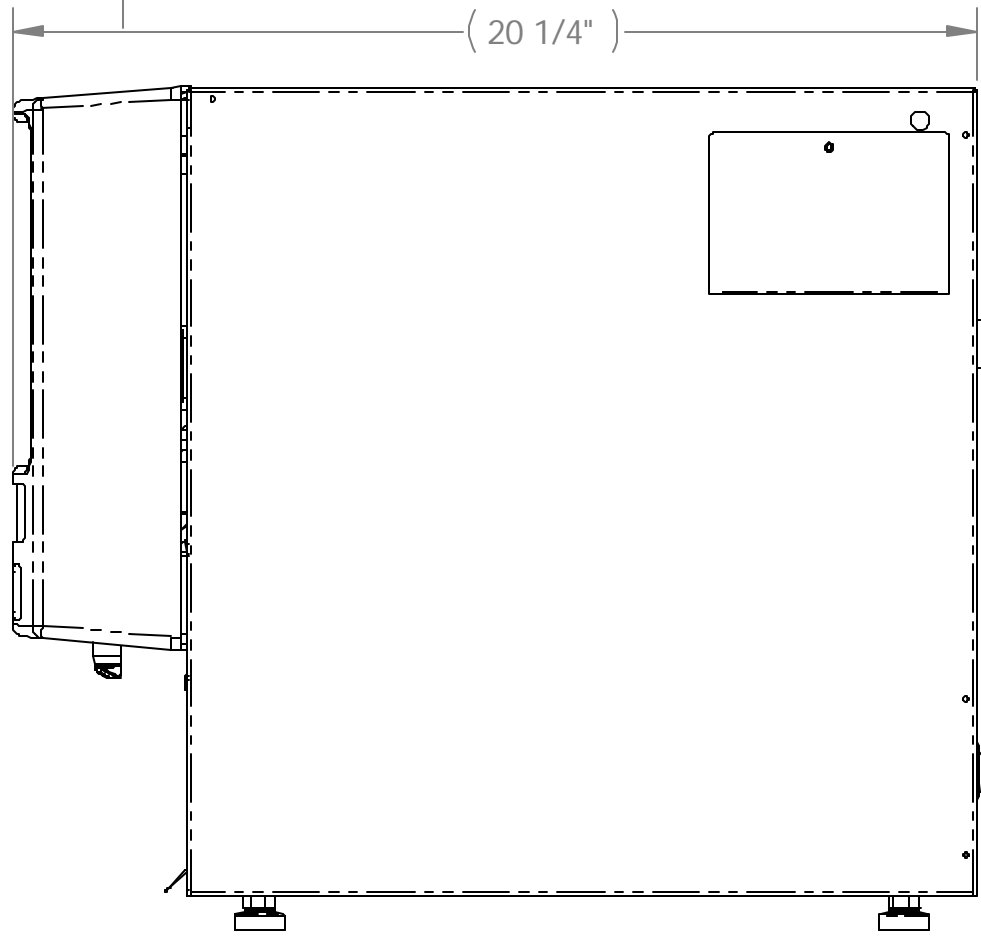
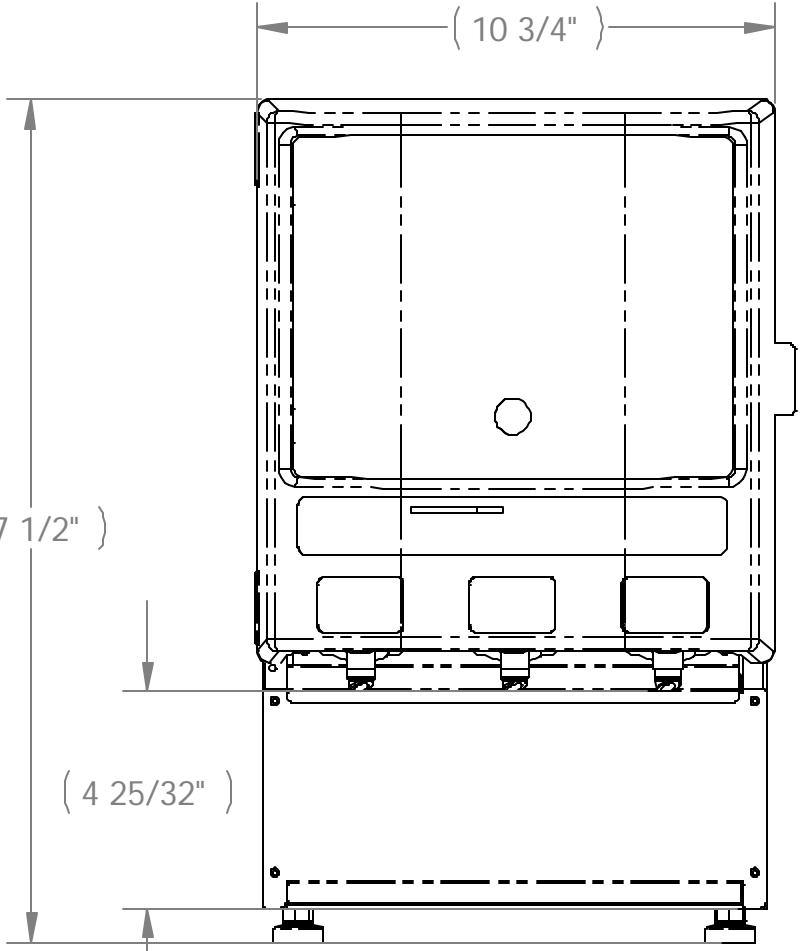

ELECTRICAL SPECIFICATIONS

Model No. Mini Cap-3 (#771040)

Volts-120 Phase-single

Hz-60

Heater 1400 w

120V, 1.4 KW, 15A.

UNPACKING INSTRUCTIONS

Carefully unpack the Mini Cap-3 Machine and inspect immediately for shipping damage. Your MC-3 Machine was shipped in a carton designed to give it maximum protection in normal handling. It was thoroughly inspected before leaving the factory. In case of damage, contact Newco.

INSTALLATION INSTRUCTIONS

Water Inlet Connection:

This equipment is to be installed to comply with the applicable Federal, State, or local plumbing codes having jurisdiction. In addition:

1. Install the quick disconnect water connection with washer (located in bag kit) to the water inlet outlet located in upper rear of machine.
2. Install the shutoff/strainer between the water line and the machine insuring the connections do not leak. Provide enough extra coiled tubing (at least 2x the depth of the unit) so that the machine can be moved for cleaning underneath.

Level the machine (using the 4 Adjustable Leveling Legs, factory installed).

START-UP PROCEDURE

1. Connect the ¼" **dia.** copper waterline to the ¼" **flare** water inlet fitting of the valve, turn water on, check for leaks.
2. Plug the power cord into a proper receptacle.
3. Activate the Power switch (Toggle Up) located on the left rear of the machine. The tank will start filling.
4. Allow approximately 3-5 minutes for the tank to fill.
If the tank does not fill up within the first 10 minutes an error message will display a blinking LED code. See Definition of Codes and Troubleshooting Guide.
5. Allow up to 30 minutes for the water to reach a temperature of 180°F.
The heat up time will depend on the water inlet temperature, the input voltage.
While the tank is heating up, remove the 2 lb. product cassettes, load them with product and reposition them back in the machine (see loading diagram page 7).
6. Adjust cup volume settings and water flow rate. (See Operating Instructions page 8)

SANITIZING INSTRUCTIONS:

Sanitizing: All food dispensing units should be sanitized weekly. All parts to be sanitized must be cleaned first.

To prepare a sanitizing solution: ADD 2 TSP. OF LIQUID CLOROX BLEACH (5.25% CONCENTRATION) TO 1 GALLON OF WATER AT ROOM TEMPERATURE (70°- 90°F).

Note: Always start with an unopened bottle of Clorox Bleach since the solution from an opened bottle has a short life span.

- Soak all parts for a minimum of 3 min. in the sanitizing solution.
- Let all sanitized parts drain and dry naturally. **DO NOT WIPE THEM DRY.**
- Before using the sanitized unit (or parts) with foodstuffs, rinse all parts thoroughly with water.

Water pipe connecting and fixtures directly connected to a potable water supply shall be sized, installed, and maintained in accordance with

Federal, State, and Local codes (section 7).

Cleaning

1. Remove the drip tray with grill and empty the contents.
2. Wash and let dry the tray and grill (use a mild dishwasher detergent).
3. Wash and let dry the dispense area.
4. Turn the power switch to ON.

Flushing the Whipper Chambers (See Illustration of Membrane Switch Page 8)

1. Push and hold any 2 dispense buttons for 3 seconds.
Whipper will run briefly to show this has been done.
2. Push and hold any dispense button to flush.
Flush will stay active as long as button is held.
3. Flush mode will end after 3 seconds of inactivity.
Whipper will run briefly to show the mode has ended.

Removing and Cleaning the Whipper Chambers (See Illustration Below and on Page 12)

1. Remove the steam cap by turning while on whipper bowl, then remove cap by pulling it upward.
2. Remove the whipper bowl by lifting upward to free from mixing chamber, then away from machine to disengage bowl stem from water outlet.
3. Turn the mixing chamber clockwise to disengage from whipper base and remove.
It is important that these two keyways are lined up when re-assembling the components.

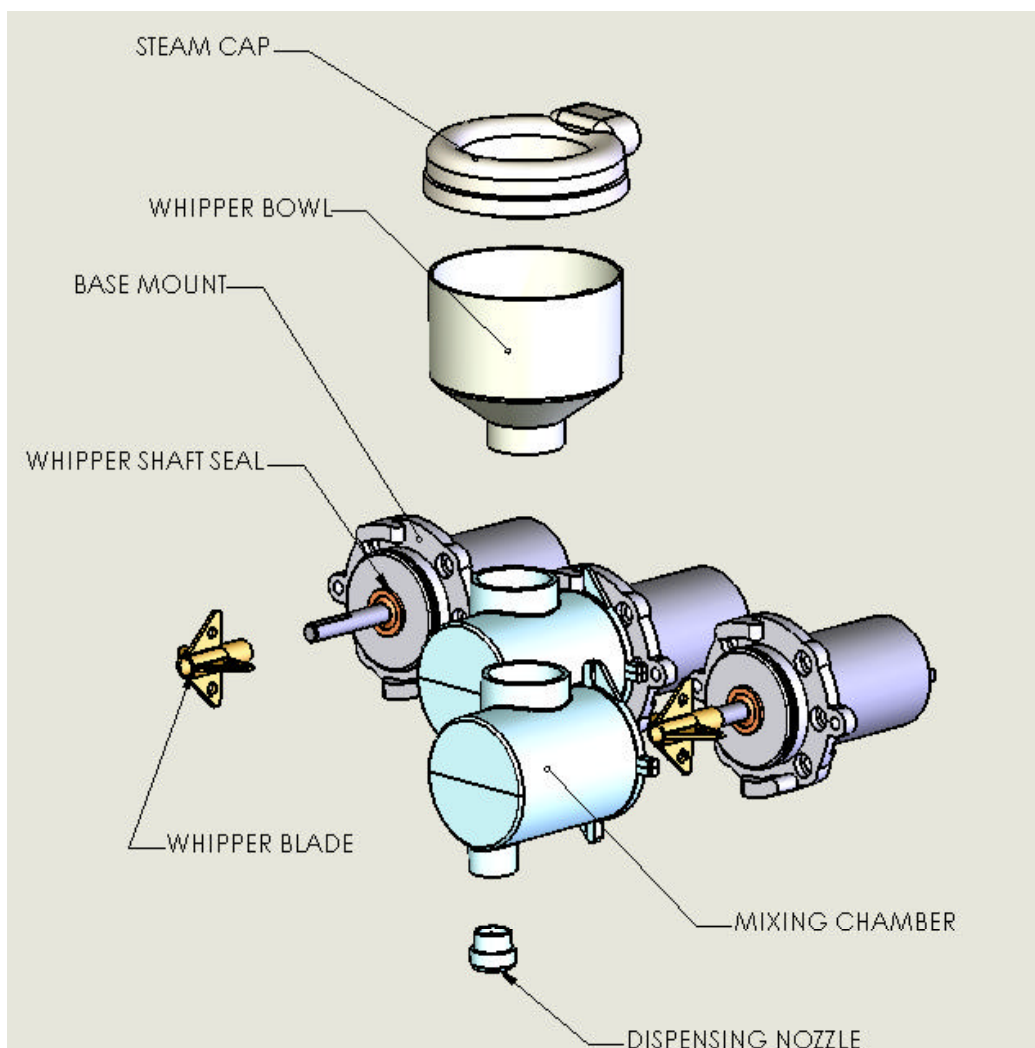

TROUBLESHOOTING GUIDE

WARNING: To reduce the risk of electrical shock unplug the dispenser power cord before repairing or replacing any internal components of the unit. Before any attempt to replace a component be sure to check all electrical connections for proper contact

Error Codes:

1 blink = water fill run-on (8 minute initial time, 20 seconds thereafter)

2 blinks = heater rise error (temperature increase within 4 minutes)

3 blinks = thermistor shorted or reading out of range (over 215°F)

4 blinks = thermistor open or reading out of range (under 32°F)

Temperature range on this machine is adjustable from 150 – 195 degrees F.

PROBLEM	PROBABLE CAUSE	REMEDY
1. No water	<ul style="list-style-type: none"> a) Water turned off b) Water line not connected c) Faulty water inlet valve 	<ul style="list-style-type: none"> a) Turn water on –open shutoff valve b) Ensure water line is connected c) Check valve and connections-replace if necessary
2. No water one channel only	<ul style="list-style-type: none"> a) Loose connection @ water pump b) Loose connector on main board c) Faulty dispense pump 	<ul style="list-style-type: none"> a) Check connectors @ water pump (see page 21 & 22) b) Make sure harness is seated and locked c) Replace water pump (PN 781690)
3. Water not hot	<ul style="list-style-type: none"> a) Temperature setting too low b) Heater overload tripped c) Defective heater element 	<ul style="list-style-type: none"> a) Adjust temperature setting (see instructions page 9) b) Reset hi-limit thermostat (Call Newco) c) Replace heater element (Call Newco)
4. Water does not shut off	<ul style="list-style-type: none"> a) Liquid level probe malfunction b) Faulty water inlet valve 	<ul style="list-style-type: none"> a) Check probe connections (see page 21) b) Check valve and connections-replace if necessary
5. Drink too strong	<ul style="list-style-type: none"> a) Water pump adjustment settings incorrect 	<ul style="list-style-type: none"> a) Adjust water pump (see page 9)
6. Drink too weak	<ul style="list-style-type: none"> a) Water pump adjustment settings incorrect 	<ul style="list-style-type: none"> a) Adjust water pump (see page 9)
7. Drink not whipped	<ul style="list-style-type: none"> a) No whipper blade b) Whipper motor connection c) Whipper motor bad 	<ul style="list-style-type: none"> a) Install whipper blade b) Inspect whipper motor connections @ motor and @ board plug-in c) Replace whipper motor
8. Exhaust fan does not turn	<ul style="list-style-type: none"> a) Fan motor connection b) Fan motor bad 	<ul style="list-style-type: none"> a) Inspect fan motor connections @ motor b) Replace fan motor
9. Noise coming from whipper	<ul style="list-style-type: none"> a) Whipper chamber not seated b) Slinger washer pushed on motor shaft too far. c) No whipper blade 	<ul style="list-style-type: none"> a) Reseat whipper chamber-see whipper cleaning instructions b) Check gap at slinger washer (see page 12) c) Install whipper blade
10. Membrane Switch does not work	<ul style="list-style-type: none"> a) No power to machine b) Power switch turned off c) Machine is in error mode 	<ul style="list-style-type: none"> a) Make sure machine is plugged in and control board has power b) Turn switch on c) Check for error signal, correct and repower machine

Product Loading Instructions

Turn Nozzles Up Prior to Removing Product Hoppers

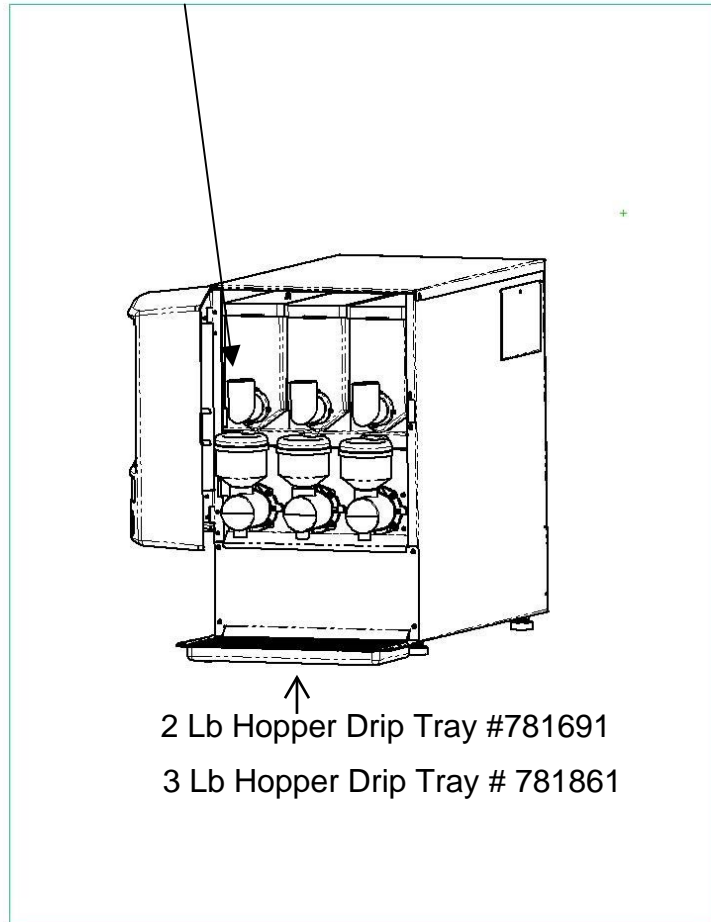

Product Hopper Removal:

1. Turn Nozzle UP as illustrated above
2. Grasp Hopper at Nozzle and lift slightly to disengage locating pin
3. Pull Hopper assembly forward and remove from machine

The Hoppers hold approximately two pounds of Product. Do not overfill or pack product in canisters. Pour Product into Hoppers in a back and forth motion to evenly distribute the powder, to avoid spilling.

Machine operation and calibration settings

Dispense Membrane Switch

PN 781596

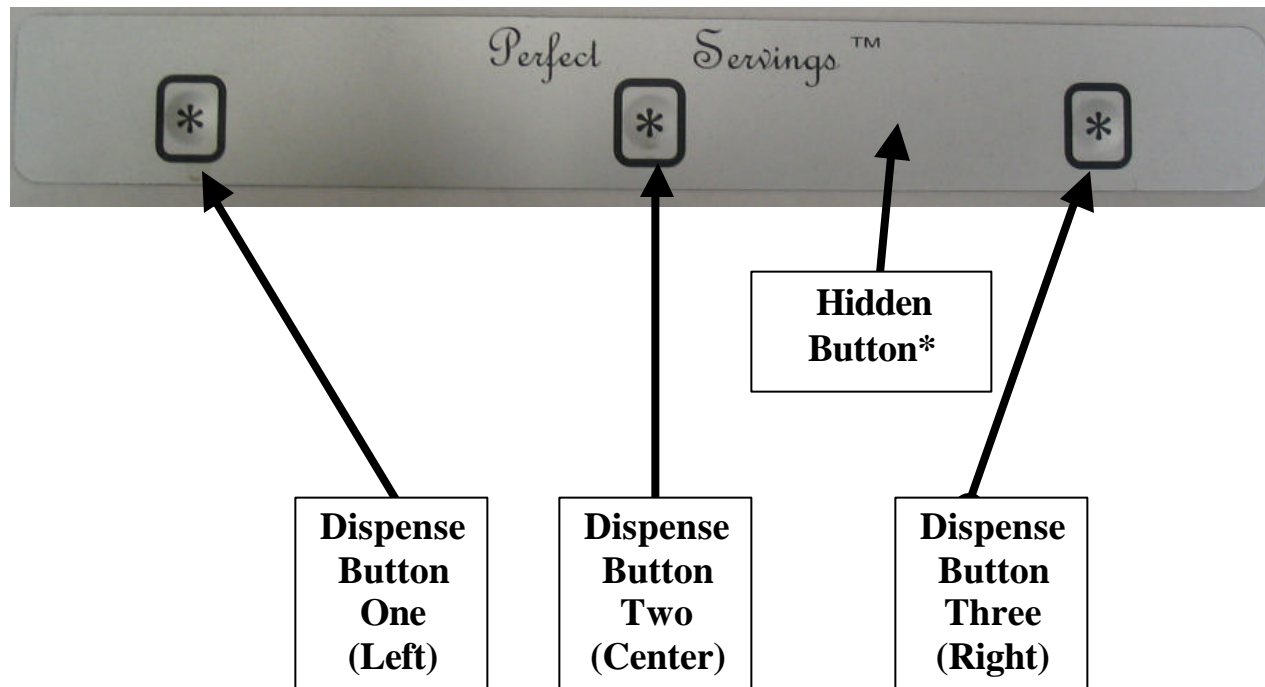

***Note:** The Hidden Button has a slight depression in the face of the membrane switch and is centered between Dispense Buttons Two and Three below the 'TM'

Portion Control Mode:

To initialize the portion control mode perform the following steps:

1. Select cup size and position under desired dispense nozzle
2. Push and hold Hidden Button
3. While holding in Hidden Button also push and hold Dispense Button which corresponds with dispense nozzle in step 1
4. After a 1-second pause the drink will start to dispense
5. Release the Hidden Button and continue holding the Dispense Button until the cup is about 2/3 full . (Hold <3 sec's resets to manual)
6. Portion size is now in memory, if incorrect repeat until desired dispense is achieved. Repeat steps for the other selections
7. Dispense can be cancelled by pressing any button a second time .

Manual Dispense Mode (Momentary)

To cancel Portion Control Mode and return to Manual Mode, follow the Portion Control Instructions-release Hidden Button in step 5 after product dispense starts in less than 5 seconds.

When using Manual Mode release the hidden button when cup is approximately 2/3 full or less.

Heater and Pump Control Interface

The Interface is located behind the access panel on the right upper rear side of the machine (see illustration page)

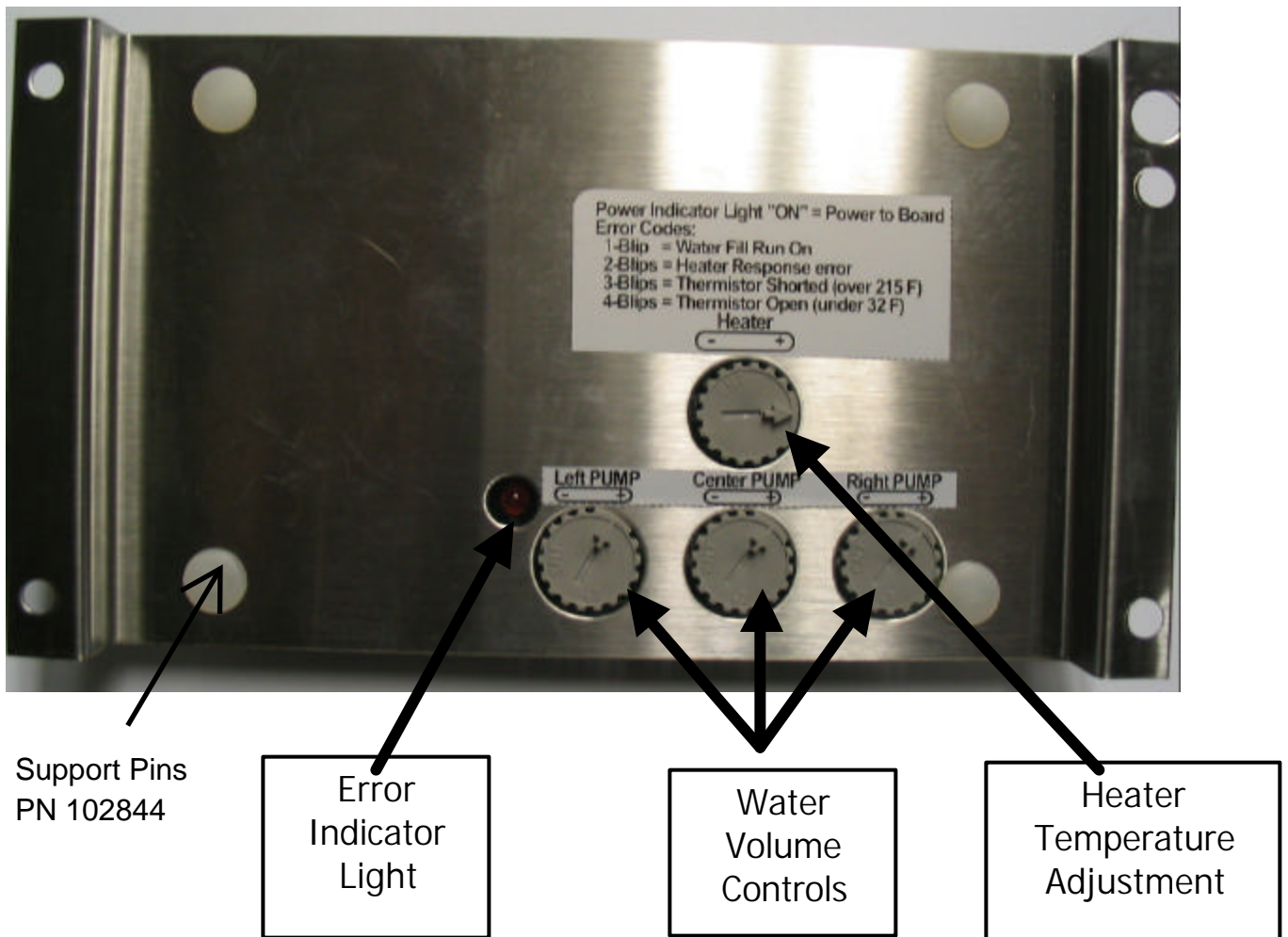

Drink Strength Adjustment

Dry Product Delivery from Canister Canisters is not adjustable. The Water Volume Controls are used to fine-tune Drink Strength

Heater Adjustment

The Heater is adjustable from a range of 150 F-195F (see illustration page 9) Note: Temperature at dispense point will be slightly lower.

Flushing the Mixing Chambers

The Mixing Chambers should be sanitized at least once per day. To initialize Sanitation Mode perform the following steps:

1. Push and hold any 2 dispense buttons for 3 seconds.
Whipper will run briefly to show this has been done.
2. Push and hold any selector button to flush mixing chamber.
Flush will stay active as long as button is held.
3. Flush mode will end after 3 seconds of inactivity.
Whipper will run briefly to show the mode has ended.

Cleaning and Sanitizing Instructions

Daily Cleaning

1. Rinse the Mixing Chambers
2. Empty the Drip Pan if needed and wash with mild detergent, rinse clean with warm water
3. Check the Canister Nozzles, clean and dry thoroughly
4. Check and clean the Sheet Metal Panels in the dispense area

Weekly Cleaning

Whipper and Mixing Chamber Disassembly and Cleaning (see Illustration page 5 & 12)

- 1. Remove the Steam Caps by Turning Clockwise to free**
- 2. Remove the Mixing Bowl by lifting the front edge of the bowl until it is free of the Whipper Chamber and pull forward to free the Mixing Bowl water inlet stem free of the Bulkhead Fitting.**
- 3. Rotate the Whipper Chamber Clockwise and pull forward to remove**
- 4. Remove Flow Restrictor by pulling free from Whipper Chamber**
- 5. Soak these parts in warm water, clean with mild detergent, rinse and sanitize (see sanitization page 4)**

Whipper and Mixing Chamber Reassembly

- 1. Replace the Flow Restrictor**
- 2. Replace the Whipper Chamber, push and twist counterclockwise until the posts on the Whipper Chamber engage and seat**
- 3. Reseat the Mixing bowl by locating the Water stem on the Mixing Bowl into the Bulkhead Fitting, tilting the bowl up. Push forward engaging the O-ring seal on the Water stem through the bulkhead fitting, then continue to push forward until the lip of the Mixing Bowl slips into the Whipper Chamber. Push down to firmly seat the Mixing Bowl**
- 4. Replace the Steam cap by seating inner lip of the Steam Cap with the upper edge of the Mixing Bowl, with the steam opening away from the sheet metal panel. When Steam Cap is seated rotate the steam opening into the slot in the sheet metal Steam Chamber opening**

Mixing/Whipper Chambers Disassembly

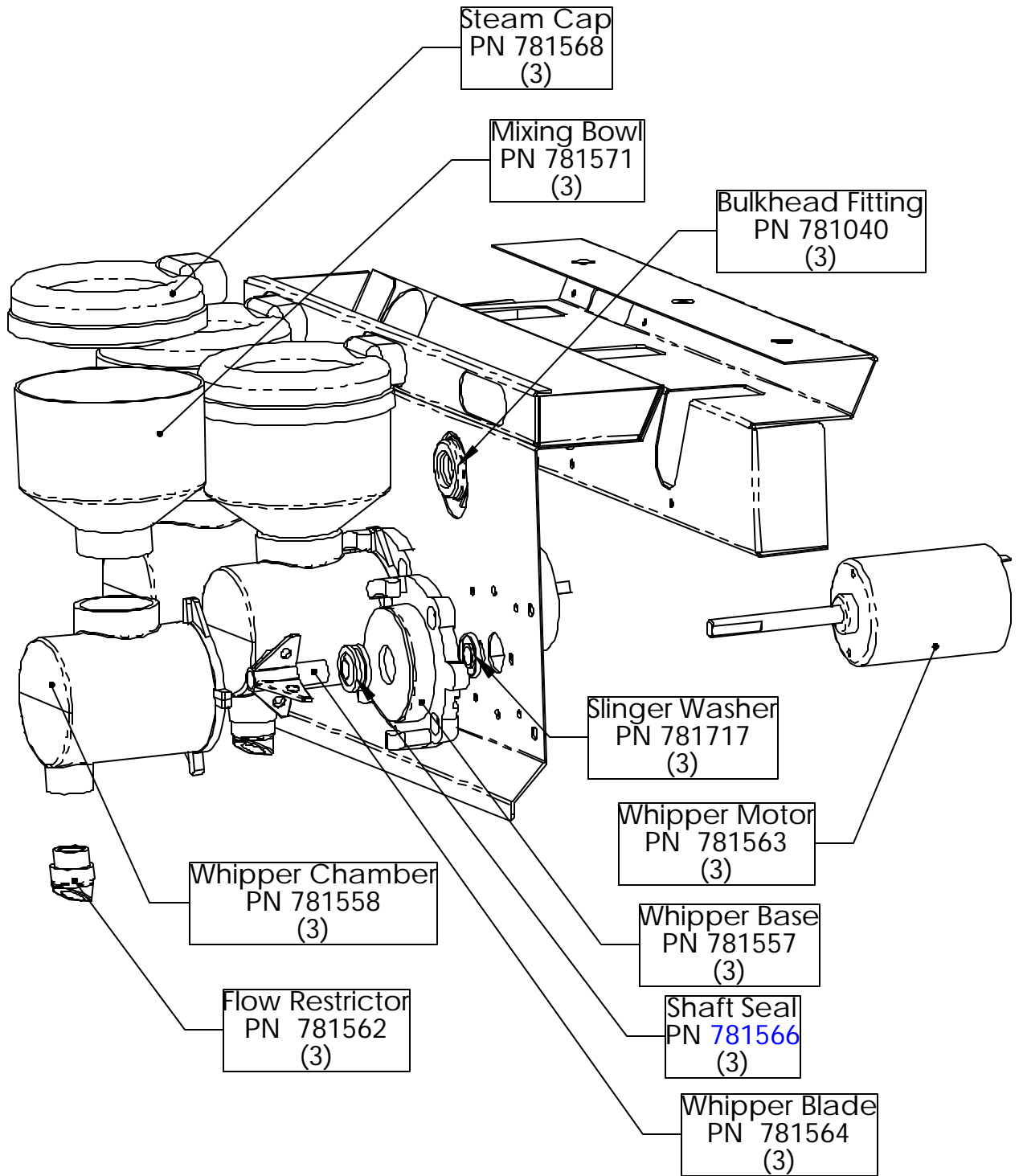

Product Canister Disassembly and Cleaning (see illustration page 15)

- 1. With door open turn the Dispense Nozzles facing up (see page 7)**
- 2. Remove the Product Canister and dispenser nozzle.**
- 3. Rotate the front Threaded Retaining wheel counterclockwise and remove**
- 4. Remove the Nozzle Bushing**
- 5. Turn the Canister around and remove the rear Threaded Retaining ring**
- 6. Pull and remove the Drive Link Assembly and Auger Spring**
- 7. Wash all components with mild detergent and warm water, rinse clean and sanitize. When washing Product Canister, rotate Auger Gear Wheel to access gear teeth and Mixing Springs**
- 8. Let all components air dry thoroughly before reassembly**

Product Canister Reassembly

- 1. Ensure all Canister components are completely dry**
- 2. Slip Drive Link Assembly and Auger Spring through the Canister and into the front opening of the Canister (Note the shape of the Canister-the Drive Link Assembly feeds in from the curved, or overhanging side and the auger tip feeds through the hole in the flat face of the Canister)**
- 3. Ensure the locating tabs on the seat of the Drive Link Assembly drop into the recesses of the hole in the Canister**
- 4. Screw the rear Threaded Retaining ring clockwise locking down the Drive Link Assembly and Auger Spring**

Product Canister Reassembly (continued)

- 5. Insert the Nozzle Bushing “facing up” as shown in the diagram**
- 6. Ensure the locating tabs on the seat of the Nozzle Bushing drop into the recesses of the hole in the Canister**
- 7. Screw the read Threaded Retaining ring clockwise locking down the Drive Link Assembly and Auger Spring**
- 8. Replace the Dispense Nozzle-seat the “short” end onto the Nozzle Bushing with the dispense opening “facing up”**
- 9. Refill Canister with product and reinstall in the machine-ensure the Drive Link Assembly engages the Auger Drive pinion gear, and the locating pin in the Canister Base drops through the locator hole in the sheet metal Canister Tray. Rotate Nozzle down into Steam Cap**

Product Canister Disassembly

PN 781857

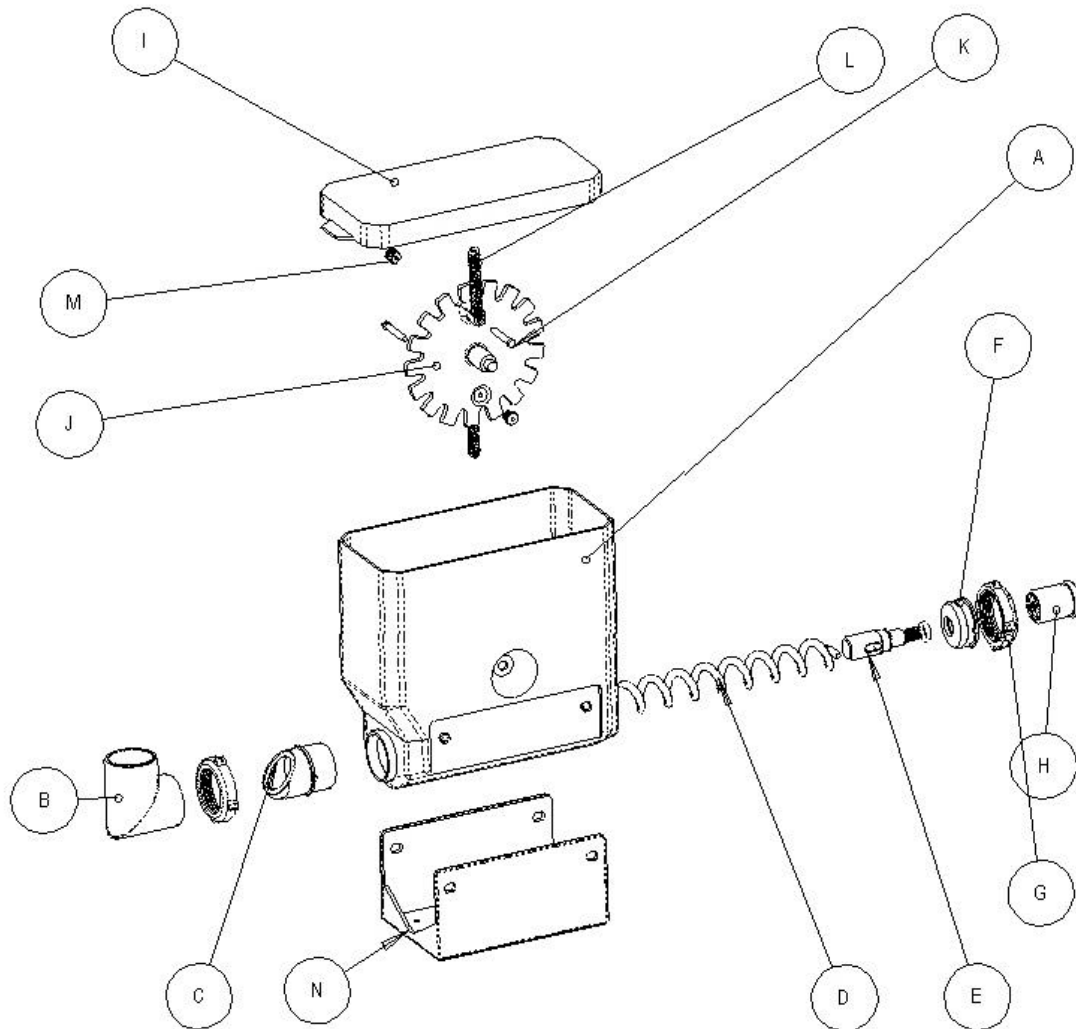

- | | |
|--------------------------------|--------------------------------------|
| A. Canister Body -PN 781855 | H. Back Motor Drive-PN 781840 |
| B. Elbow-Dispense-PN 781833 | I. Hopper Lid-PN 781583 |
| C. Nozzle-PN 781584 | J. Mixing Gear-PN 781828 |
| D. Auger Spring -PN 781835 | K. Mixing Spring Screw-PN 781830 (2) |
| E. Front Motor Drive-PN 781836 | L. Mixing Spring-PN 781830 (2) |
| F. Bushing-PN 781838 | M. Mixing Spring Nut-PN 781832 (2) |
| G. Nut-PN 781839 (2) | N. Canister Base-PN 781841 |

Note - 3 lb Cannister Ass'y is PN 781864 . 3 lb Cannister body is PN 781582

Steam Tray Removal

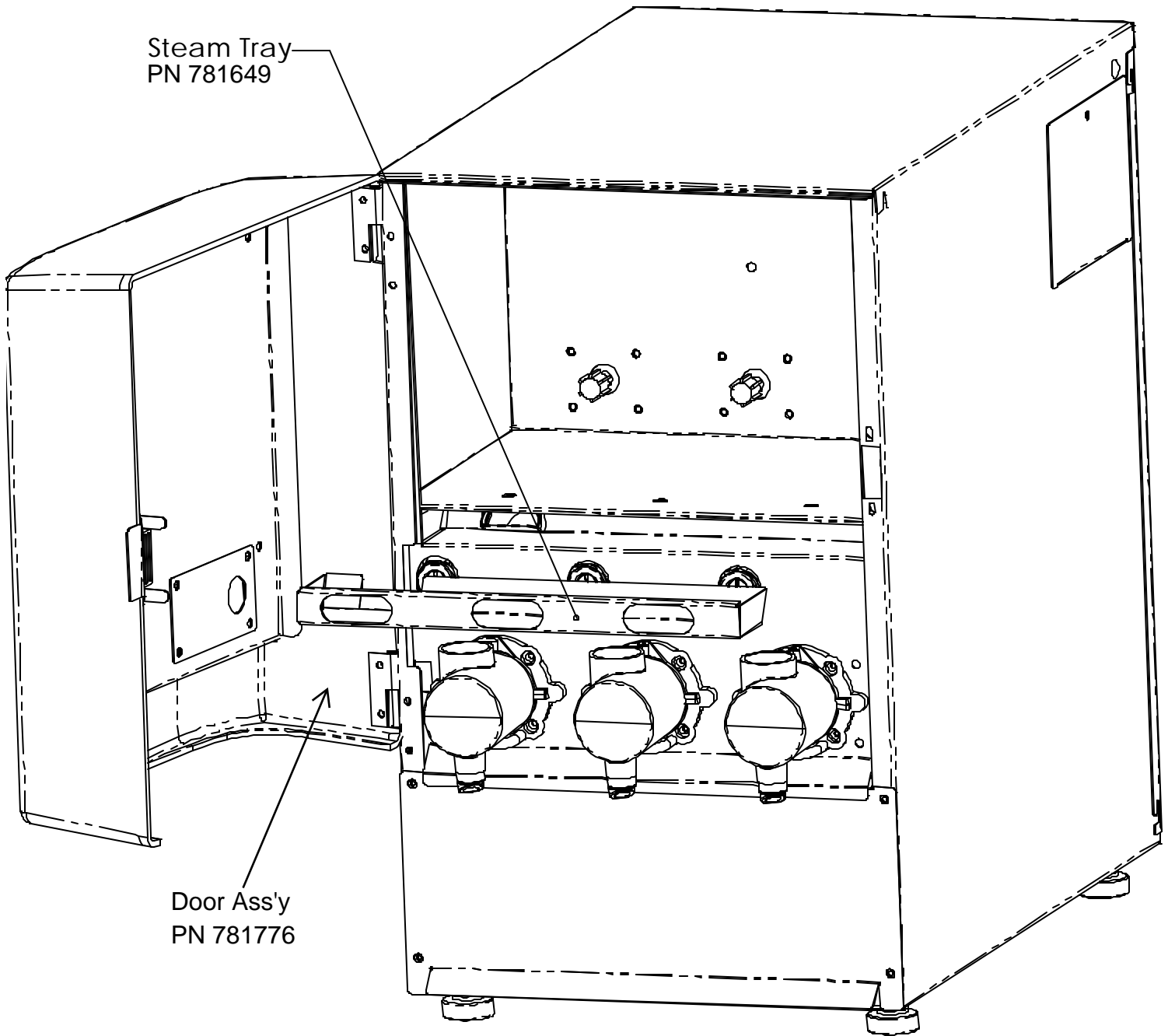

Steam Tray
PN 781649

Door Ass'y
PN 781776

Cleaning Brush is PN 111622, Brushholder bracket is PN 104023

Service Procedures

Note: Servicing this unit should be done by authorized personel only. Before Servicing unit:

- 1. Turn Power Switch to Off Position**
- 2. Unplug Power Cord from outlet**
- 3. Disconnect water line (ensure water supply to machine is turned OFF!)**
- 4. Water in tank is HOT! Drain tank contents and let tank cool before servicing unit (see Illustration page 18)**
- 5. Loosen sheet metal screws as indicated in Illustration page 19 . Slide Cover towards rear of machine and remove. Remove water line and slide back panel up and away from cabinet**

Front Access Panel Removal

Board Access Panel
PN 108014

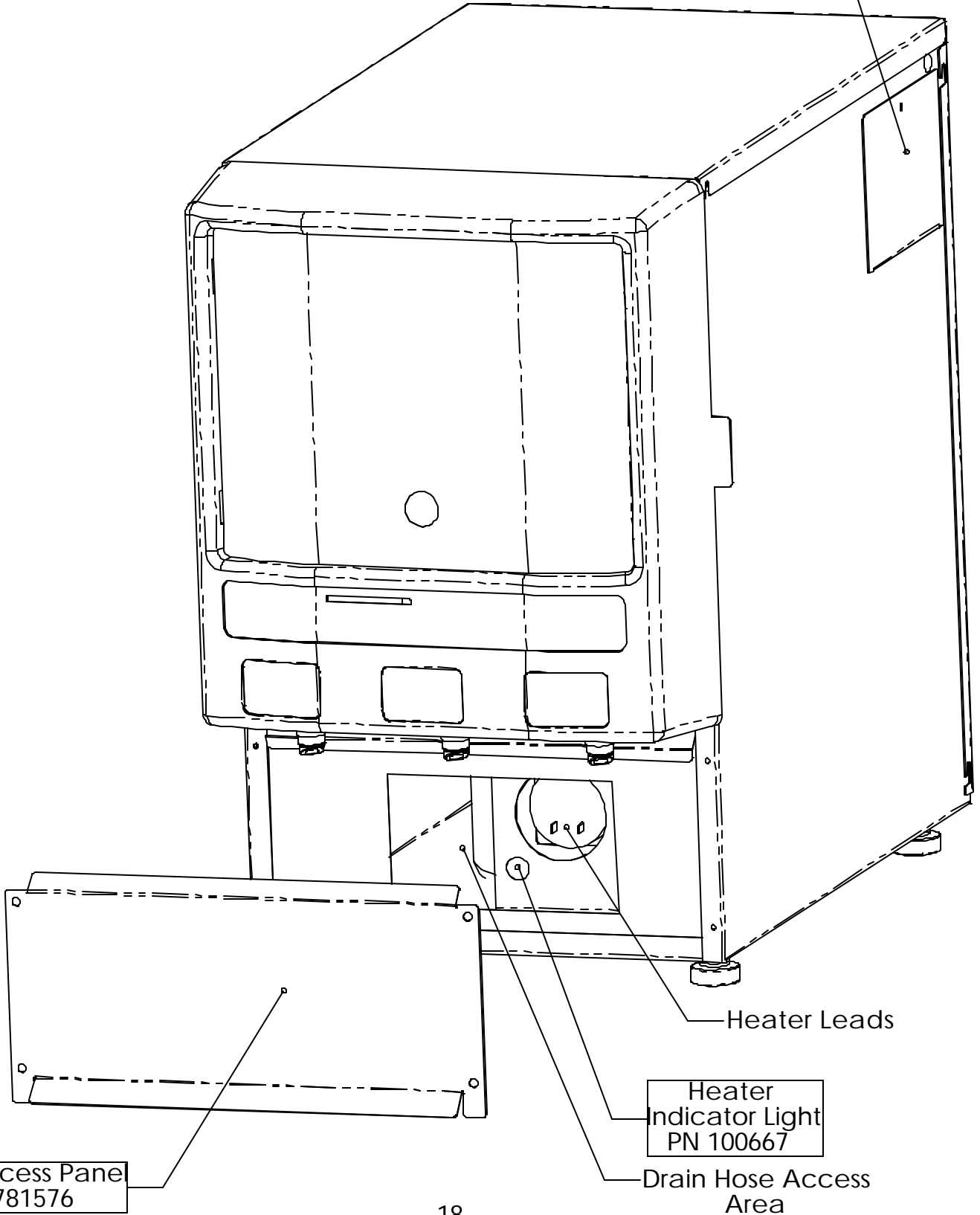

Front Access Panel
PN 781576

Heater
Indicator Light
PN 100667

Drain Hose Access
Area

Sheet Metal Panel Removal Access Screws

2 LB Cover PN 781597
3 LB Cover PN 781851

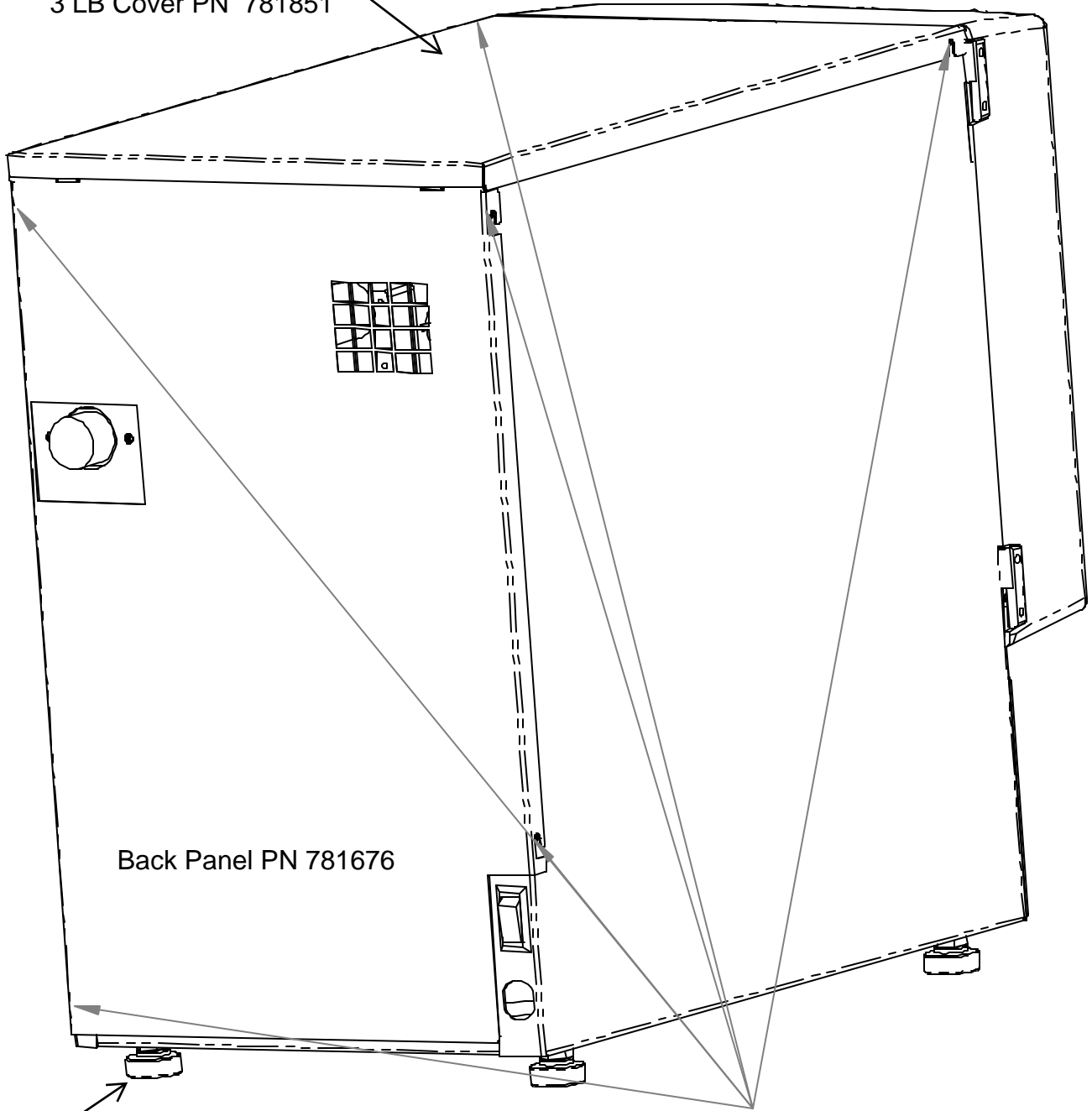

Back Panel PN 781676

2 LB Legs PN 111377
3 lb 4" Legs PN 100542

Loosen Screws:
Note: It is not necessary to completely remove these six screws to remove cover and back panels

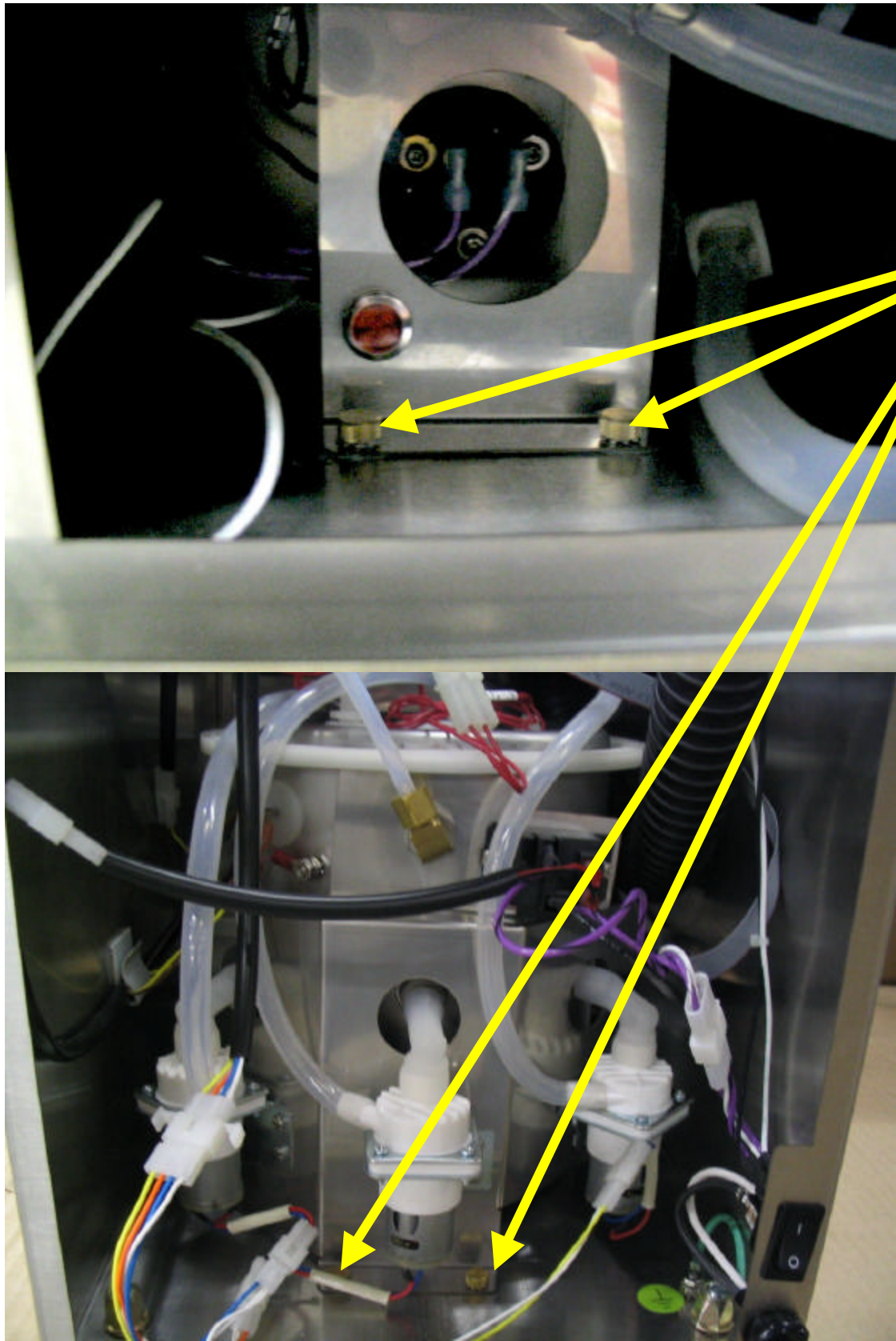

Tank
Release
Screws
Front
PN 100425

**Tank Disconnects
Prior to
Removal**

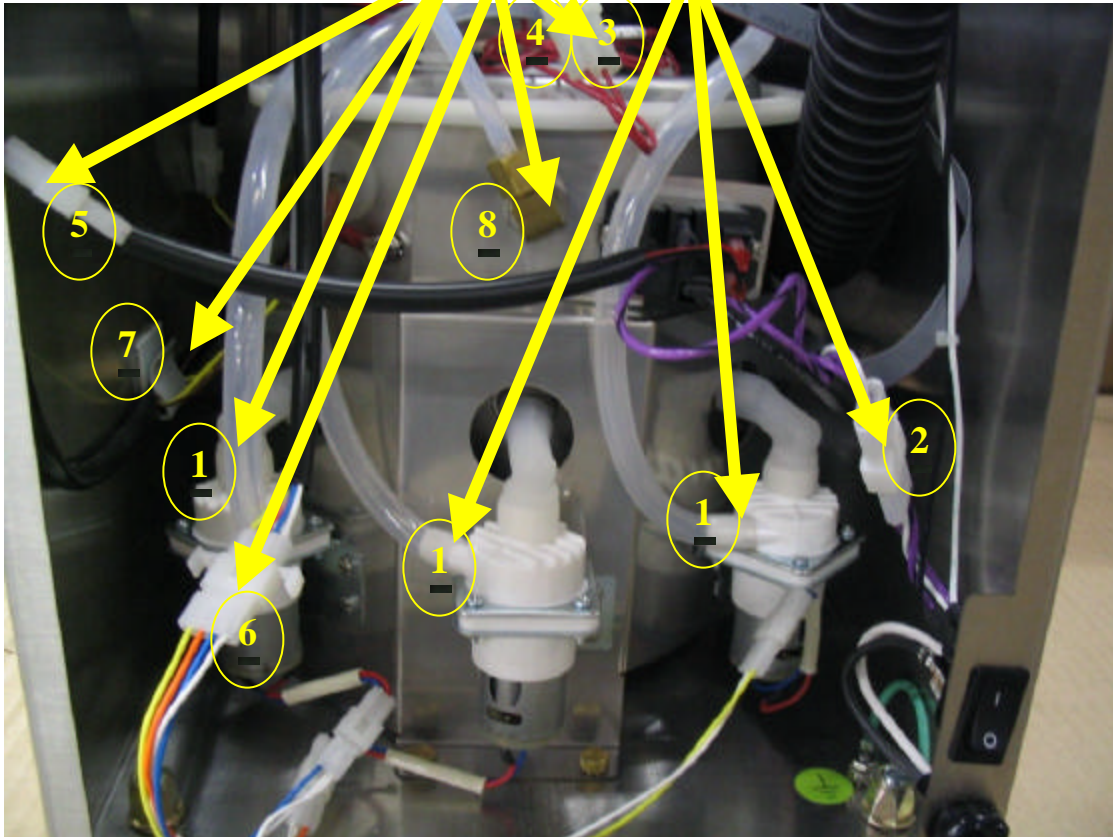

Disconnect:

- 1. Pump Tubes (3)**
- 2. Main Power Connector**
- 3. Float Switch Connector**
- 4. Thermistor**
- 5. Relay Connector**
- 6. Pump Connector**
- 7. Probe Connector**
- 8. Water Line**

Tank Assembly PN 781673

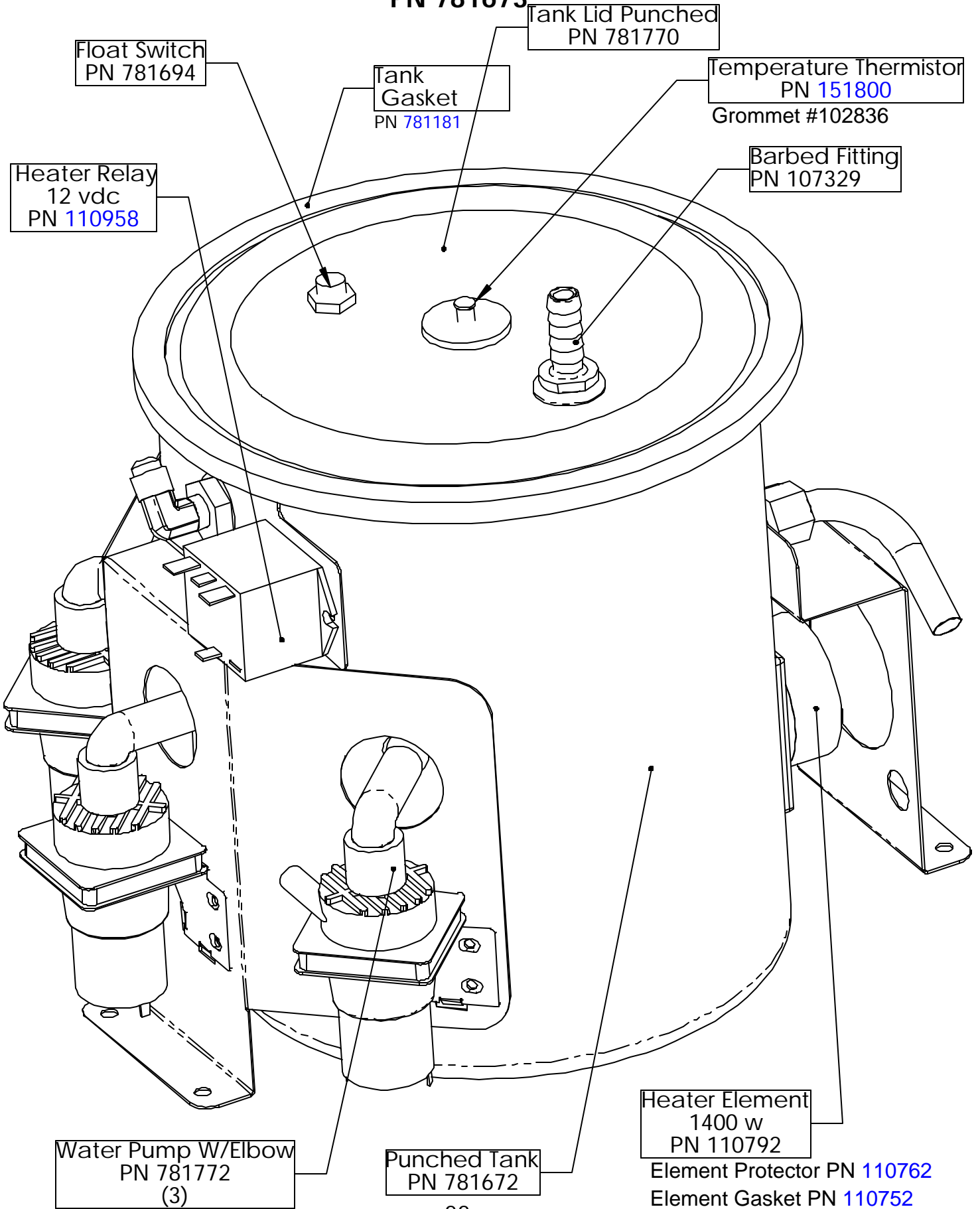

Components Top and Rear Access

