



**NU·VU<sup>®</sup>** FOOD SERVICE SYSTEMS

For NU-VU<sup>®</sup> Model:

# **PROW-18**

# **OWNER'S MANUAL**

MENOMINEE, MICHIGAN 49858  
(906) 863-4401 • (800) 338-9886

Revised:  
27 July, 2006

# PROW-18

## TABLE OF CONTENTS

ABOUT YOUR NU-VU® EQUIPMENT.....	1
NU-VU® EQUIPMENT WARRANTY.....	5
RECEIPT AND INSTALLATION .....	8
INITIAL START-UP.....	11
PRODUCT PREPARATION AND USE OF UNIT ..	13
OPERATING INSTRUCTIONS.....	17
GENERAL PROOFER SETTINGS.....	18
MAINTENANCE AND CLEANING GUIDE .....	19
TROUBLE-SHOOTING GUIDE .....	21
SERVICE AND REPLACEMENT GUIDE.....	24
REPLACEMENT PARTS LIST.....	36

# ABOUT YOUR NU-VU® EQUIPMENT

NU-VU® as a product line has been in existence for over twenty-one years. Its units are in use throughout the United States and Canada and have been exported to other parts of the world. NU-VU® continually modifies and updates its equipment to improve the capabilities as new innovations become available. This enables the user to obtain better and more useful results. NU-VU® currently manufactures an entire line of equipment in Menominee, Michigan. All of the equipment is tested under anticipated operating conditions prior to shipment. Any prospective customer is invited to try different food products in the newly completed test kitchen in Menominee.

Seminars for both dealers and customers are available either on-site in Menominee, Michigan; at the dealer's showroom; or on the customer's premises. Technical product information can be generated by customer requested testing of various products.

NU-VU® can provide a wide range of equipment with any of the following features:

- Bakery Ovens with either INTERNAL or EXTERNAL STEAM generating capabilities. These Ovens may be equipped with COOK-N-HOLD capabilities for broader use.
- COOK-N-HOLD Ovens for either high temperature or low temperature operation with moisture and smoking capabilities.
- Low temperature Ovens with moisture and smoking capabilities.
- Steamer Ovens with high and low temperature capabilities.
- Multi-Ovens that dry bake, steam, and bake with steam.
- Bakery Proofer/Warmers with moisture and heat generating units with either MANUAL FILL or AUTOMATIC HUMIDITY systems.
- General purpose Proofer/Warmers for reconstituting, slow cooking, holding and/or steaming.

NU-VU® Food Service Systems offers the widest range and variety of equipment through the varied use of heat, moisture, steam and smoke options. NU-VU® has, over a period of time, developed a series of Ovens, Proofers, Steamers, Smokers and Warmers designed to provide maximum performance with minimum energy requirements and care by the operator. This is embodied in the V-AIR principle.

V-AIR stands for versatile air movement equipment. NU-VU® has, in the V-Air line, combined quality construction, long life components, superior performance, multiple use operation and amplified operating procedures to produce the finest equipment available. This means the end user has the best of ALL worlds.

One of the previous problems of circulating air ovens was the inability to bake dough products evenly without turning the pans or taking the pans out of the oven at different times. In the standard convection oven the air is blown around randomly and thus the different shelves have different conditions.

NU-VU® offers the V-AIR series of Ovens and Oven/Proofer combinations with a patented positioned air flow system. NU-VU®'s patented system enables the user to load the Oven completely with pans having the same product, bake, and remove the entire load at the same time. This is possible because the air is directed in at each shelf through holes in the sidewalls. Because each shelf receives essentially the same air pattern the bake is uniform.

Since the air flow is in a directional pattern the baking times are reduced over conventional deck and tray ovens. Actual baking times depend on the recipes used, baking temperature, proofing conditions, dough quality and environmental conditions.

V-AIR principles can be applied to a range of equipment. For instance, it can be employed in table-top, floor model and roll-in Oven or Oven/Proofer combinations. V-AIR is applicable for both high and low temperature operations and results in multiple uses for a single piece of equipment:

- Proofing, warming, holding, cooking, reconstituting, steaming, and smoking products at lower temperatures of 250°F or less.
- Cooking, baking, steaming and smoking products at temperatures up to 500°F and then automatically reducing the temperature to 160°F or so for holding purposes.
- V-AIR uses either fan movement of air, natural air current, or a combination of fan movement and natural air currents, depending upon the application.
- V-AIR is used in conjunction with added moisture where necessary for obtaining the best possible food quality.
- V-AIR employs separate Temperature and Humidity Controls to produce most of the conditions required by different foods and processes.

A specific unit can be designed and produced according to the customer's needs to provide usage for either a special product or a variety of needs.

The particular atmosphere employed depends upon the nature of the food products and the desired end result. For instance, some food products may be immersed in moisture during the cooking cycle and the addition of supplemental moisture may be unnecessary. Other food products may lose moisture when cooked and would dry out without the addition of supplemental moisture.

NU-VU® utilizes separate controls in conjunction with the desired air movement to supply the desired level of heat and moisture. When using both heat and moisture the temperature of the unit's atmosphere results from a combination of the heat and moisture sources.

Because of the separate controls it is possible to have a number of different conditions:

- Heat, moisture, natural air
- Heat, moisture, fan
- Heat, no moisture, natural air
- Heat, no moisture, fan
- Moisture, no heat, natural air
- Moisture, no heat, fan

By providing separate controls it is possible to obtain any of the above conditions. In addition to the above conditions, based on normal heat and moisture conditions, the use of a STEAM and/or SMOKE options offer other variations.

The choice of air movement is an important consideration because it affects the moisture content of the food product. As a general rule food cooked at a lower temperature without fan air movement will retain more moisture. The use of low temperature "still air" cooking is utilized to minimize "shrinkage", or drying of the product. Thus, when fan air movement is used the addition of supplemental moisture in the Oven atmosphere acts to compensate for the tendency of the product to lose moisture.

The use of forced air movement by fan accomplishes the following:

- Gives a broader use of the equipment
- Speeds the food treatment cycle
- Provides uniform heat and moisture throughout the unit

NU-VU® V-AIR equipment offers the widest range of options by the use of different air flow systems in conjunction with heat, moisture, steam and smoke.

## **NU-VU® MODEL PROW-18:**

The NU-VU® PROW-18 Proofer measures 78" in height (including Casters), 26" in width, and 31" in depth (plus 3½" for the Door Latches), and occupies approximately *5½ square feet of floor space.*

The PROW-18 Proofer is electrically powered and is equipped with NU-VU®'s AUTO-MIST Humidity System to provide controlled humidity levels during the proofing cycle. The Dutch Door design comes complete with stainless steel Side Racks capable of supporting a maximum capacity of 18 full size 18" x 26" sheet pans. All Controls are conveniently placed across the top of the unit.

The NU-VU® PROW-18 Proofer can be used for the following products:

- Breads
- Rolls
- Pastries
- Pizza Crusts
- Croissants
- Raised Donuts

and any other miscellaneous products that may require proofing.

The NU-VU® PROW-18 Proofer is designed with these features in mind:

- Automatic pan positioning
- Rapid, even proofing
- Easy cleaning
- Simple operation
- Dependable components
- Low energy consumption
- Low maintenance
- Rapid servicing

## **AVAILABILITY AND TESTING:**

A prospective customer may see a unit in operation as follows:

- At a dealer's showroom;
- At an existing installation;
- At NU-VU®'s manufacturing facility.

If contacted, NU-VU® will provide the information on the nearest location. In the event that a customer desires to test a unit at his place of business, arrangements can be made based on a specifically defined program. In the event that a customer wants to try a special product, arrangements can be made to determine what conditions are necessary for proper operation so the customer can determine the suitability for his program.

## COMPARISON WITH OTHER UNITS:

NU-VU® will provide test data or a test unit for the comparison of results with any other unit on the market; however, NU-VU® reserves the right to have its designated representative or representatives available during the test. All results of such comparison tests will be made available to NU-VU® and may be used by NU-VU®. Based on production of consistent quality products from the PROW-18 Proofer, as well as cycling times, NU-VU® outperforms the competition.

## CONSTRUCTION:

The NU-VU® PROW-18 Proofer is constructed of polished stainless steel both outside and inside. All of the exterior frame members are welded to provide long life construction. Components such as temperature and humidity controls, switches, motors, heating elements and others are thoroughly tested before shipment. On-going research and development projects are used to introduce the latest and most dependable parts.

## SHIPMENT:

NU-VU® equipment is shipped directly from the factory or delivered from a dealer unless sold at a show or after a test or demonstration. Unless otherwise agreed to by NU-VU® freight is paid by the buyer F.O.B. from NU-VU®'s manufacturing plant in Menominee, Michigan. Shipping time may vary depending upon the original shipping point, time of the year, and shipper or shippers used.

NU-VU® employs the latest accepted packaging standards to ensure that your equipment arrives in excellent condition. However, damage may still occur due to accident or negligent handling. For this reason it is necessary for the receiving party to immediately do a thorough inspection of the equipment when it arrives. NU-VU® works closely with all of its customers in tracing shipments to speed deliveries and minimize handling.

### **\*\*\* NOTICE \*\*\***

**NATIONAL SANITATION FOUNDATION GUIDELINES REQUIRE THAT ALL INTERIOR PARTS BE REMOVABLE WITHOUT THE USE OF TOOLS. THIS EQUIPMENT HAS BEEN FACTORY ASSEMBLED TO SAFELY ACCOMMODATE ROUGH HANDLING THROUGH SHIPMENT AND ORIGINAL INSTALLATION. AFTER ANY MAINTENANCE, CLEANING OR REQUIRED SERVICE WORK THE INTERIOR SHEET-METAL PARTS SHOULD BE RE-ASSEMBLED AND FASTENED HAND-TIGHT ONLY, BUT STILL REMAIN TIGHT ENOUGH TO PREVENT ANY RATTLE OR MOVEMENT OF PARTS.**

# NU-VU® EQUIPMENT WARRANTY

NU-VU® products are warranted against defects in workmanship and materials. No other express warranty, written or oral, applies. No person is authorized to give any other warranty or assume any other liability on behalf of NU-VU®, except by written statement from an officer of NU-VU®.

Your NU-VU® equipment warranty is limited to the following time periods for the original owner only:

	<u>PARTS</u>	<u>LABOR</u>
Inside the United States	12 Months	12 Months
All areas outside the United States	12 Months	12 Months

These time limits will apply in all cases unless prior arrangements have been made and agreed to in writing.

The NU-VU® EQUIPMENT WARRANTY is composed of the following:

## CONSTRUCTION - -

This warranty covers fabricated metal parts such as side walls, element covers, tops, corner posts (where used), bases, welded frames and other parts for the lifetime of the unit. The unit is made from welded stainless steel (or aluminum where applicable) and is warranted to retain the integrity of its construction during its time of use in the *original* location of installation. NU-VU® reserves the right to provide the method of, and person to make, any required repairs.

## PARTS - -

This limited warranty covers certain electrical, electronic, and mechanical parts for the time periods described above with the exception of those items detailed under Warranty Limitations. Customers who maintain an open account may purchase against their account. MasterCard, Visa and American Express credit cards are also accepted.

The return of defective parts is required. The return of a defective part or component must be made prior to the issuance of a credit on an open account. If a part that is returned tests satisfactory in the NU-VU® factory or at an authorized NU-VU® dealer or service agency, NU-VU® may withhold issuing credit. Replacement parts will be warranted for a period of *ninety (90) days* provided they are installed in a manner authorized by NU-VU®.

## LABOR - -

We require that you call our NU-VU® Service Department at (800) 338-9886 for service authorization BEFORE you call any service agency if you wish to claim a labor expense under the warranty. We may be able to solve your problem over the telephone, or we will schedule a warranty service call by a reliable service agency in your area.

This warranty covers the replacement and installation of parts and components which are included under **PARTS** for the appropriate time period indicated on the previous page. This coverage is limited to the normal mileage allowance for a maximum travel radius of up to fifty (50) miles, and the normal labor rate times the allowable hours for performing the work as set forth in the following listing:

## **NU-VU® FOOD SERVICE SYSTEMS STANDARD TIME ALLOWANCES FOR WARRANTY REPLACEMENTS**

<u>Change performed</u>	<u>Change time</u>	<u>Test time</u>	<u>Total time</u>
Control and Sensor	¾ hr.	½ hr.	1¼ hr.
Heat Element	½ hr.	½ hr.	1 hr.
Contact/Relay	½ hr.	5 min.	½ hr.
Motor	½ hr.	5 min.	½ hr.
Power Switch	¼ hr.	5 min.	¼ hr.
Indicator Light	¼ hr.	5 min.	¼ hr.

These times are based on servicing a unit that has been installed with allowance made for access panels on the unit. If the unit is built into a wall that makes servicing very difficult or impossible without removing part of the counter, wall, trim, etc., the extra time for gaining access shall be charged to the owner of the unit.

NU-VU® has determined that the listed times, which are based on the period of time necessary for a trained service person to perform the work noted, are fair and reasonable. If a problem is not diagnosed within a half hour, the service person must contact the NU-VU® Service Department via telephone. The Service Department is available for assistance Monday through Friday from 7:00 a.m. to 5:30 p.m. (Central Standard Time). Additional time for problem solving will not be allowed unless this procedure is followed. An appointment for servicing a unit should be set up since time will not be allowed for waiting to service a unit. Unless the service person justifies extra time for performing the work noted, charges for work performed by the service person in excess of the allowed time shall either be billed to the owner of the equipment or denied.

### **EXTENDED WARRANTY:**



**IMPORTANT: NU-VU® WILL NOT PAY FOR ANY SERVICE CALLS AS WARRANTY WORK IF A NU-VU® AUTHORIZED SERVICE AGENCY DETERMINES THAT YOUR UNIT IS SET UP AND OPERATING PROPERLY!**

Available at an additional charge. Please ask for a quote depending upon warranty requested.

### **WARRANTY LIMITATIONS:**

NU-VU® will pay for parts and labor under warranty if there is a defective component, but not for:

- Parts damaged in shipment beyond the confines of the NU-VU® factory.
- Normal operational wear and tear on the following parts -
  - Light bulbs and fuses
  - Door handles, catches and gaskets

- Damage attributable to customer abuse, including but not limited to -
  - Proofer water pan allowed to run dry and burn
  - Proofer fan motor damaged from not following outlined Dry-Out Procedure
  - Lack of regular cleaning and/or maintenance
  - Leaks resulting from the removal of sealant in the unit
- Power supply problems, including -
  - Insufficient or incorrect voltage
  - Damage to electrical components caused by a power surge or spike
  - Incorrect installation (i.e., separate neutral and ground not supplied, or incorrect location of high-voltage power leg for 240-volt 3-phase units)
  - Damage to electrical components resulting from use of an incorrect power supply cord or circuit breaker
- Operational problems resulting from customer's failure to follow established procedures outlined in the Owner's Manual.
- A service call if nothing wrong is found (parts still work per spec when tested).
- Recalibration of temperature and humidity controls (all controls are carefully calibrated and tested at our facility before shipment).
- Any equipment moved from the place of original installation unless NU-VU® agrees in writing to continue the warranty after the relocation.
- Ongoing operational adjustments due to changing environmental conditions or normal wear and tear.
- Any overtime charges. NU-VU® will pay straight time only for any work performed on NU-VU® equipment.

Food service equipment and parts must be installed and maintained in accordance with NU-VU® instructions. Users are responsible for the suitability of the units or parts to their application. There is no warranty against damage resulting from accident, abuse, alteration, misapplication, inadequate storage prior to installation, or improper specification or other operating conditions beyond our control. Claims against carrier's damage in transit must be filed by the buyer and, therefore, the buyer must inspect the product immediately upon receipt.

**THIS WARRANTY DOES NOT COVER ADJUSTMENTS  
DUE TO NORMAL ON-GOING USE!!!**

## **PARTS RETURN PROCEDURES AND CONDITIONS:**

The following procedure shall be followed for the return of parts to the factory for credit consideration:

- All parts received by NU-VU® must have a completed Return Authorization Form as supplied by NU-VU® with the part. Complete and return this Authorization Form with the defective part(s).
- Parts MUST be packed securely so that in-transit damage cannot occur.
- Prepay shipment. Any parts returned collect will be refused by our Receiving Department. Credit will be issued on proper returns only.
- As soon as parts are tested and confirmed as defective, credit will be issued.
- If the engineering test shows the component is not defective and in good working condition, it may be returned to you along with your request for payment.

# RECEIPT AND INSTALLATION

## RECEIPT:

It is essential to inspect the unit immediately when it arrives. NU-VU® has placed instructions on the packaging to help avoid damage in transit. However, negligent handling can produce hidden damage. These steps should be followed:

- A. Inspect the entire perimeter of the package for damage or punctures to the packing material. This may indicate damage to the unit inside. Call any and all packing damage to the attention of the trucker.
- B. If any packing damage is found uncrate the unit immediately *in the presence of the delivery person* to determine if the unit is damaged. If any damage is found indicate the type and amount of damage on the shipping documents and notify NU-VU® at (800) 338-9886 immediately after filing a freight claim.
- C. Uncrate the unit carefully and check the entire unit (top, sides, front and back) for any visible or hidden damage.
- D. Remove the unit from the shipping pallet and inspect the bottom (including the Casters) for any damage.
- E. If any damage is noted after the driver leaves immediately contact the freight company and NU-VU® Food Service Systems.
- F. Check the Proofer Doors. Make sure both Doors close completely and evenly around the entire perimeter. If they do not, please contact NU-VU®'s Service Department for instructions and assistance in any required adjustments.

## INSTALLATION:

Move the unit to the area where it will be used. Adjust the unit as necessary until it stands level and solid. Use thin metal shims under the Casters if necessary.

## WATER SUPPLY CONNECTION - -

**IMPORTANT:** NU-VU® strongly recommends that *SOFT WATER ONLY* be used in any unit requiring a water supply. Also, a good quality water filter **MUST** be installed in-line between the unit connection and the water supply to guard against clogging and mineral build-up in the components. This is extremely important in areas having hard water. This water filter may be installed at the water source or adjacent to the Water Inlet Fitting [38] on the unit, whichever is more convenient for you.

- A. Run ¼" tubing from the water source to the unit's location. Allow some slack for final unit positioning and service. Avoid any kinks or strains on the tubing and place the tubing where it will not be damaged in any way.
- B. The tubing end that attaches to the unit must not be damaged or deformed in any way. The cut end should be cut straight and clean with no deforming of the tubing. All burrs and sharp edges should be removed to ensure a proper and leak-free connection.
- C. Position the tubing so that the tubing runs straight into the Water Intake Fitting [38]. Be careful not to kink the tubing if you bend it, and do not bend the tubing within two (2) inches of the end.

- D. The two-part compression fitting (tapered collar and nut) is placed approximately 1" onto the tubing so that the collar is inside of the nut and the threaded opening of the nut is toward the intake fitting.
- E. Push the tubing all the way into the Water Intake Fitting (approximately ¼") and hold it there while you thread the compression nut onto the Water Intake Fitting. Tighten the compression nut with a ½" open-end wrench, *but do not over-tighten the fitting!* If the joint leaks when tested and further gentle tightening does not stop the leak the two-part compression fitting must be replaced.

Careful attention to these simple procedures will help to ensure an installation without leaks. If you have any questions or problems please call NU-VU®'s Service Department at (800) 338-9886.

***IMPORTANT:** The NU-VU® PROW-18 Proofer is equipped with a bottom Floor Drain that extends down through the Base of the unit. This Drain prevents the build-up of excess water. Please install the included Drain Pan [40] in the bracket under the front of the Proofer before attempting an INITIAL START-UP and operational check, OR you can attach any locally required and/or approved drain plumbing at this time.*

## ELECTRICAL CONNECTION - -

Check to determine that the power source is the same voltage and phase as that required by the unit. The electrical requirements for the PROW-18 are listed on a grey metallic label affixed to the side of the unit. If your voltage and/or phase is not the same as called for on the label please call NU-VU® for instructions on changing the voltage and/or phase of your equipment or power source.

Connect your unit according to all applicable local and national codes, either with a plug-type connection or through direct wiring. All connections should be made with COPPER WIRE ONLY in the correct gauge for the application. Allow enough slack in the wiring to allow for equipment to be moved about during the installation and any required servicing or maintenance.



**IMPORTANT: DO NOT ATTACH UNIT IF THE POWER SOURCE DOES NOT COINCIDE WITH THE UNIT LABEL!!!**

Please observe the following steps to correctly connect your NU-VU® PROW-18:



**WARNING: ALL POWER SHOULD BE TURNED OFF AT THE MAIN BREAKER WHILE THE UNIT IS BEING CONNECTED!!!**

- A. Your qualified equipment installer or electrician should remove the Outside Top [36] of the unit to expose the wiring connections at the Power Terminal Block [1]. A copy of the unit's wiring schematic should be attached to the wiring near the Power Terminal Block.

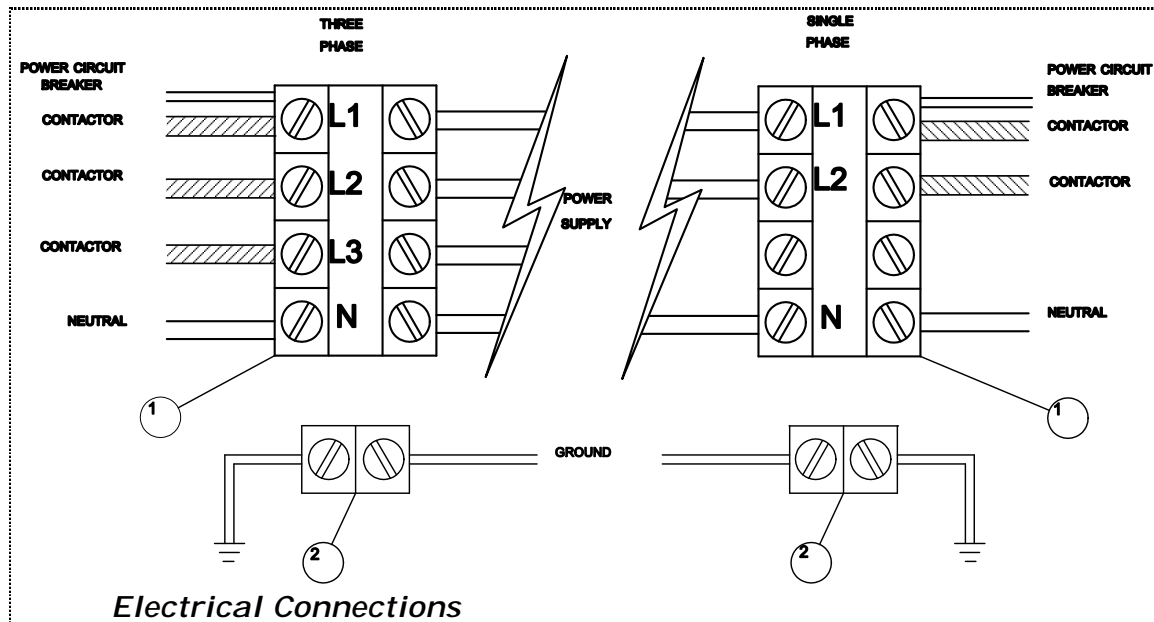

- B. Take note of the connection labeling on the Power Terminal Block (**Line 1**, **Line 2**, **Line 3**, and **Neutral**). Carefully identify the power source connections and attach them to the appropriate terminals on the Power Terminal Block (refer to the illustration above). Make sure all connections are clean and tight.

***NOTE:** The PROW-18 is engineered to accept either a 208-volt or 240-volt power supply. All interior electrical components operate from one power leg or the other at 120-volts to neutral. If your place of business has a 240-volt **THREE** phase power supply be sure you run only the two 120-volt legs to a unit requiring single phase power. If your PROW-18 requires three phase power the wild power leg must be connected to **L-2** on the Power Terminal Block.*

- C. Be sure the unit is properly grounded before use by attaching a grounding wire to the Ground Lug [2] next to the Power Terminal Block.
- D. Carefully set all Controls and Switches to their **OFF** positions and engage the main power supply.
- E. Check the voltage at the Power Terminal Block connections with a voltmeter to confirm compatibility with the unit requirements (120 volts to neutral from each power leg). If all voltage readings are correct you may proceed with the *INITIAL START-UP*. If the readings **DO NOT** coincide with the unit requirements you must call NU-VU® for instructions on changing the voltage and/or phase of your equipment or power source. If you do not intend to proceed immediately with the *INITIAL START-UP* procedures please replace the Outside Top.

# INITIAL START-UP

This START-UP procedure is used to verify that your unit has been installed correctly and will perform as intended when you put it into use. Please read completely through all the START-UP procedures before you begin.

The installation of your NU-VU® PROW-18 should be complete and correct before you attempt a START-UP. Please verify the following items before you begin the procedures for the Proofer START-UP:

- Outside Top [36] removed to expose the electrical connections.
- Water supply line connected to the ¼" Water Inlet Fitting [37] on the back of the unit and tested for leaks.
- A good quality water filter must be installed in the water line between the unit and water source.
- Any required drain plumbing installed. If no drain plumbing is required, a pan or tray should be placed under the Drain opening in the bottom of the Proofer.
- 208v or 240v electrical supply connected to the Terminal Power Block [1], and ground wire connected to the Ground Lug [2]. All electrical connections must be clean and tight.
- Unit positioned under ventilation hood (if required) in operating area.
- All Controls and Switches on the PROW-18 must be in their OFF positions.
- Main water supply turned ON.
- Main electrical supply turned ON.

## PROW-18 START-UP PROCEDURE:

- A. Open the Proofer Doors [31].
- B. Set the Proofer Power Switch [11] to the **ON** position. The Power Indicator Light [12] will illuminate and the Blower Wheel [22] under the Element Cover [21] in the top of the Proofer will begin to rotate in a *counter-clockwise* direction.
- C. Set the Humidity Control [17] to #10. The Humidity Control Indicator Light [18] will illuminate and a light water mist will be sprayed from the Injection Nozzles [23] into the Proofer Blower Wheel. In a second or two the spray will stop and the Indicator Light will go out. After a short pause the Humidity Control will cycle again. After three or four cycles set the Humidity Control to **OFF**.

***NOTE:** The AUTOMIST Humidity System controls the humidity level in the Proofer by using a solid-state Repeat Cycle Timer [7] with a fixed "OFF" time of 45 seconds and an adjustable "ON" time from 0.0 to 2.0 seconds. Changing the setting of the Humidity Control varies the "ON" time and thus regulates the duration of the water spray.*

- D. Close the Proofer Doors. Set the Proofer Temperature Control [14] to any selected proofing temperature (generally 90° to 105°). The Temperature Control Indicator Light [15] will illuminate and the Heating Elements [5] begin to get hot.
- E. Place a reliable oven thermometer or other test instrument in the center of the Proofer. Allow the Proofer to heat up and the internal temperature to stabilize.
- F. While the Proofer is still heating up, use an ammeter to measure the amperage draw on each incoming power feed line at the Power Terminal Block [1]. Please call NU-VU®'s Service Department immediately if these readings vary by more than 1 or 2 amps from the nominal values listed on the side of the unit.
- G. Check the reading of the thermometer or test instrument against the Temperature Control setting when the Temperature Control Indicator Light goes out. If the readings differ by more than 5° but less than 15° the Temperature Control may need a simple dial adjustment (refer to *TEMPERATURE CONTROL, How to Adjust* in the *SERVICE AND REPLACEMENT GUIDE*). Please call NU-VU®'s Service Department BEFORE attempting to adjust or recalibrate any temperature control!

### START-UP FINAL CHECKS - -

- Replace the Outside Top, being careful not to pull or pinch any wires while installing the Panel. Replace any other Access or Service Panels that may have been removed during the INSTALLATION or START-UP procedures.
- Place the PROW-18 in its final operating position and lock the front Casters [39]. Place shims under the Casters to make the unit sit level and solidly in place.
- Make sure adequate clearance is maintained at the back and both sides of the unit to provide for adequate cooling and ventilation.

***YOUR PROW-18 SHOULD NOW BE READY FOR OPERATIONS!***



**IMPORTANT: FAILURE TO FOLLOW THESE INSTRUCTIONS, FAULTY INSTALLATION, OR IMPROPER USE MAY CAUSE SEVERE EQUIPMENT DAMAGE OR PERSONAL INJURY, AND MAY VOID ALL OR PART OF YOUR NU-VU® EQUIPMENT WARRANTY!!!**

# PRODUCT PREPARATION AND USE OF UNIT

Proper handling of food product and proper use of the equipment is essential to end product quality. For purposes of preparation it is important to do the following:

## KNOW YOUR OPERATION - -

- A. Determine your raw material requirements and storage space.
- B. Get a production planner for daily use.
- C. Make out a production schedule based on manpower requirements and product delivery times.
- D. Prepare a brief job description for your help and determine what employees will be trained to handle the various production steps.

## KNOW YOUR PRODUCT - -

- A. If using a frozen dough supplier consult the manual which describes the initial steps for the product, as well as proper procedures during proofing and baking or cooking. If you do not have a manual from your supplier you may obtain a manual of general information from NU-VU®.
- B. Study the manual and make up a list of questions.
- C. Contact a representative from the food product supplier to obtain answers to your questions.
- D. Sign up to attend a seminar or training session to learn specifics.
- E. Try to get some "hands-on" training time prior to starting up your own operation.
- F. In general the same steps used for a thawed frozen product will be applicable to a scratch or mix program. However, temperature and moisture settings may vary due to a difference in dough composition and consistency.

## KNOW YOUR EQUIPMENT - -

- A. Read this manual and study the Operations and Servicing sections. Make sure that the equipment you are using is installed correctly and is applicable to the product or products you wish to prepare.
- B. Contact NU-VU® if any of the information provided here is not clear or if you have any problems or questions.

## USING YOUR NU-VU® EQUIPMENT:

As indicated in your bakery manual some products require "proofing", or a period for the yeast to act and the dough to rise.

Many factors affect the quality of the end product. For yeast products the major factors are dough preparation, proofing and baking. The manner in which the dough is prepared affects the proofing process. If the dough is prepared from basic raw ingredients or from prepared mixes the user should receive the necessary training in product preparation.

The basic yeast dough should be at room temperature when placed in the Proofer. Your baking manual gives instructions in dough treatment, proofing and baking. NU-VU® equipment is suitable for use with all types of dough. Changes in the actual proofing conditions depend on the conditions in the area of the Proofer as well as the Proofer settings themselves.

All yeast products should be baked immediately after proofing to obtain optimum results. The quality of the product that you prepare in your NU-VU® Proofer depends on several factors:

- Initial product quality
- Proper mixing, panning and/or thawing
- Proper proofing
- Correct baking temperature
- Correct baking time

It is important that *any* product be properly prepared. Your equipment cannot correct *improper procedures* or *poor dough product*. The manual or instructions you receive from your product supplier should give general instructions for preparation, proofing and baking along with specific instructions for the associated product. As a rule of thumb you need to:

- Properly thaw frozen products.
- Properly proof all yeast products.
- Properly bake the products.

Taking shortcuts in the thawing or proofing processes will not permit a successful bake.

Follow these general instructions for proper results:

- A. Set out the desired product for thawing (if necessary). Be sure to allow sufficient time in your production schedule for your Proofer to reach the correct operating conditions (refer to the table of General Proofer Settings on page 18).

*TIP: Begin preheating the Proofer when product is first put out to thaw.*

- B. Thaw the product:



**IMPORTANT: DO NOT TURN THE HUMIDITY CONTROL ON UNTIL YOUR PRODUCT IS READY FOR THE PROOFER! RUNNING THE HUMIDITY CONTROL WITHOUT PRODUCT IN THE PROOFER MAY CAUSE EXCESSIVE WATER BUILD-UP IN THE BOTTOM OF THE PROOFER, LEADING TO THE PREMATURE FAILURE OF A PROOFER COMPONENT!!!**

1. Air thaw the product from 45 to 90 minutes, depending on size and type of product, size of the load, product spacing, pan spacing, room temperature and room humidity. Check often and regularly.
2. Dough must not become dry enough to form a skin. Spray with a mist of fresh clean water if necessary. Spray only to moisten product and leave a slight glaze, *but do not saturate!*

3. Thaw until dough is soft and pliable all the way through. Product centers should not be hard or stiff, and should be easily penetrated by finger pressure.
4. Compare thawed product from both the outside and center of pans. Thaw must be even and equal to ensure a good proof and bake.

*TIP: Begin preheating your oven at the beginning of the proof cycle.*

C. Proof the product:

1. Load the product into the Proofer. Center the pans front to back and side to side as much as possible on each shelf to allow proper air circulation. Set the Humidity Control [17] to #3 or #4, and note the proofing start time.
2. Check the progress of the proof after about 20 minutes; product should be starting to rise. Dough should not be so moist as to be sticky or so dry as to form a skin.
  - a. If too wet decrease the Humidity Control setting by ½ or 1; if very wet (saturated) decrease the Humidity Control setting by 1 or 1½ and increase the Temperature Control [14] setting by 5° (see "d").
  - b. If too dry increase the Humidity Control setting by ½ or 1; if very dry (starting to form a skin) spray the product with clean fresh water until slightly glazed (see "d").
  - c. If excessive wetness or dryness continues and changes in the Humidity or Temperature Control settings have little or no effect you must check the Proofer's humidity function for proper operation:
    - i. Does the Humidity Control cycle ON and OFF?
    - ii. Is water being supplied to the Proofer?
    - iii. Is an Injection Nozzle [23] clogged or damaged?
    - iv. Is the product pan spacing correct? Pushing pans all the way to one side or against the back may restrict the air flow and prevent proper proofing.
  - d. Recheck the proof 5 to 10 minutes after making adjustments. Readjust as necessary.
3. Monitor progress of the proof more closely as you approach the end of the proofing cycle.

*TIP: Do not open the Proofer Doors [31] more often than is required or keep them open any longer than necessary.*

4. Product is generally ready to bake when it is  $\frac{1}{2}$  to  $\frac{3}{4}$  of the desired finished size. Bread dough should just stick to your finger when you touch the loaf, but still pull off cleanly when you withdraw your finger. Dough that is not slightly tacky or has a flat dull appearance is too dry. Dough that is too sticky or has a shiny or glazed appearance is too wet. These conditions may be remedied as follows:
  - a. Too dry:
    - i. Spray with fresh clean water, OR:
    - ii. Turn the Temperature Control [14] **OFF**, turn the Humidity Control [17] to maximum. Check every few minutes until dough is correct.

- b. Too wet:
  - i. Open a Proofer Door [31] to vent the excess humidity. Close the Door and monitor the product, OR:
  - ii. Turn the Humidity Control to **OFF**, turn the Temperature Control to 110°. Check every few minutes until dough is correct.
- D. Bake the product:
  - 1. Make sure your oven has reached the correct preheat or baking temperature.
  - 2. Open the oven door, load the product quickly, close the oven door securely.
  - 3. Set the proper baking temperature (if different from your preheat temperature) and the desired bake time minus two minutes.
  - 4. Check your product at the end of the baking time.
  - 5. Remove product when it is finished and reload with fresh product. Repeat steps "2" through "5".
  - 6. When baking is finished for the day complete the *DAILY DRY-OUT PROCEDURES* for the Proofer (refer to the *MAINTENANCE AND CLEANING GUIDE*).
- E. If you have a problem with the end results it can usually be attributed to one of the following:
  - 1. Problems with the dough itself. *If you have humidity in the Proofer and the correct temperature set but the dough does not rise, you have a dough problem and not an equipment problem!*
  - 2. Proofer temperature is too low. Proper proofing occurs from 95° to 105°.
  - 3. Proofer temperature set too high. Yeast will begin to deteriorate and die at temperatures over 110°F.
  - 4. Lack of sufficient moisture or too much moisture will both affect your finished product in terms of color and appearance.
  - 5. Products not proofed long enough will appear small and heavy.
  - 6. Products that are over-proofed will tend to collapse and shrink after baking and may have dark streaks across them. The size of your product when removed from the Proofer prior to baking should only be  $\frac{1}{2}$  to  $\frac{3}{4}$  the size of the desired finished product.
  - 7. Baking temperatures too high or time too long. Product will have dark spots and/or ends and edges.
  - 8. Baking temperature too low or time too short. Product will be uneven or too light in color and will be unbaked on the inside.

# OPERATING INSTRUCTIONS

The NU-VU® PROW-18 Proofer is an 18-pan Dutch Door Proofer designed to meet the needs of most operations. It is simple to install, requiring only a ¼" exterior water hook-up and a 208-volt or 240-volt single phase electrical connection, and is just as easy to operate. These simple basic procedures should guide you through the proofing process. If you have any questions, problems or comments please call NU-VU® at (800) 338-9886 and ask for the Service Department. Someone there will be glad to assist you.

## TO OPERATE THE NU-VU® PROW-18 PROOFER:

- A. Set out the desired product for thawing. Be sure to allow sufficient time in your production schedule for both the product and your equipment to reach the correct conditions.
- B. Prepare the Proofer:
  1. Set the Proofer Power Switch [11] to the **ON** position.
  2. Set the Proofer Temperature Control [14] to the required setting (refer to the table of General Proofer Settings at the end of this section) at least 20 minutes prior to use. Leave the Humidity Control [17] set to the **OFF** position.



**IMPORTANT: DO NOT TURN THE HUMIDITY CONTROL ON UNTIL YOUR PRODUCT IS READY FOR THE PROOFER! RUNNING THE HUMIDITY CONTROL WITHOUT PRODUCT IN THE PROOFER MAY CAUSE EXCESSIVE WATER BUILD-UP IN THE BOTTOM OF THE PROOFER, LEADING TO THE PREMATURE FAILURE OF A PROOFER COMPONENT!!!**

3. When your product is ready and **JUST PRIOR TO LOADING PRODUCT INTO THE PROOFER** set the Humidity Control to the required setting (refer to the table of General Proofer Settings at the end of this section).
4. The Proofer is ready for use when the Indicator Lights go out.
- C. Load the product. Center the pans front to back as much as possible in the Proofer to allow proper air circulation over and around your product. Close the Proofer Doors [31] completely.

***NOTE:** The Indicator Lights will come on again as the Temperature and Humidity Controls regulate the conditions in the Proofer. This is normal and may happen several times during a proofing cycle.*

- D. Set the 60-Minute Timer [13]. This Timer can be used as a reminder to check your product periodically, or to tell you when your product should be ready to bake.
- E. Monitor the proofing process. Your Proofer is functioning properly if there is a slight fogging on the Doors. No fogging means your Proofer may be running too hot, too dry, or both. Excessive fogging (with water running down the glass) means your Proofer may be running too cold, too wet, or both. Check the product and adjust the Proofer controls as necessary.

***TIP:** If water accumulates on the floor in front of your Proofer from drippings out of the Door you are probably proofing with too much humidity. Decrease the Humidity Control setting. If water on the floor is a constant problem for you please call NU-VU®'s Service Department at (800) 338-9886.*

- F. Your product can be baked when it is fully proofed. Yeast products should be  $\frac{1}{2}$  to  $\frac{3}{4}$  of the desired finished size at the end of the proof cycle. Generally speaking yeast products should also be slightly tacky to the touch as they are loaded into the oven.



**IMPORTANT: ALWAYS REDUCE THE HUMIDITY CONTROL SETTING TO A MINIMAL LEVEL WHEN YOU ARE RUNNING THE PROOFER WITHOUT PRODUCT INSIDE!!!**

### GENERAL PROOFER SETTINGS

<u>PRODUCT</u>	<u>TEMPERATURE</u>	<u>HUMIDITY</u>
Croissants	85°– 90°	2 – 3
Bread	100°– 105°	3 – 4
Rolls	100°– 105°	3 – 4
Danish	95°	2 – 3

# MAINTENANCE AND CLEANING GUIDE

NU-VU® equipment is designed to last for years of useful service. Careful consideration is given in selecting components for durability, performance and ease of maintenance. For example, the Proofer Motor has sealed bearings and never needs to be lubricated.

While NU-VU® equipment is designed for minimum care and maintenance certain steps are required by the user for maximum life and effectiveness:

- Proper installation of the equipment.
- Correct application and usage of the equipment.
- Dry-out Procedures performed daily.
- Thorough cleaning on a regular basis.

## EQUIPMENT INSTALLATION - -

- A. Install the NU-VU® PROW-18 Proofer with adequate clearance around the unit. This is important for cleaning and maintenance, as well as providing cooling air for the Proofer Motor and Controls.
- B. The Proofer must be installed on as level and stable a surface as possible. Shims may be placed under the Casters as necessary so that the unit is completely stable and the Proofer Doors operate easily and close completely.
- C. The PROW-18 Proofer must be connected to the proper power supply (208 or 240 volts AC, single phase).
- D. The Proofer bottom Drain must be connected to an approved floor drain or a small pan or tray placed under the Proofer Drain before commencing operations.

## APPLICATION AND USAGE - -

- A. The PROW-18 Proofer is designed for the low temperatures normally found in proofing operations (90° to 105°F). Continuous operation at maximum temperatures and/or humidity settings may result in premature component failure.

## PROOFER DRY-OUT PROCEDURE - -

- A. Wipe up any standing water in the Proofer bottom.
- B. Empty and clean any pan or tray under the Proofer Drain at least once daily.
- C. Turn the Proofer Power Switch [11] **ON**. Leave the Temperature Control [14] at its normal setting and turn the Humidity Control [17] to **OFF**.
- D. Leave the Proofer Doors open about 1" to 2" and allow the Proofer to run for approximately 30 minutes.
- E. Turn the Proofer Power Switch **OFF**. Leave the Proofer Doors slightly open (about 1" to 2") while the Proofer is not in use.



**IMPORTANT: THESE DRY-OUT PROCEDURES MUST BE CARRIED OUT DAILY TO HELP MAINTAIN YOUR EQUIPMENT IN THE BEST POSSIBLE CONDITION. THE REMOVAL OF RESIDUAL MOISTURE EXTENDS THE USEFUL LIFETIME OF YOUR NU-VU® EQUIPMENT!!!**

## **CLEANING - -**

Your NU-VU® PROW-18 should be cleaned daily and as soon as possible after a spill has occurred. It is essential to maintain a clean unit, especially if the public views the unit in your place of business. The following should be used for cleaning:

- A. The stainless steel exterior may be cleaned with any good stainless steel cleaner or polish, or with hot soapy water followed by a clear rinse if it is very soiled.
- B. The Proofer Door glass may be cleaned with any good glass-cleaning formula. Be sure to wipe down the Door Frame, and to clean the Gasket [35] on the back side of each Door. Dried-on debris or heavy soiling can be removed with hot soapy water followed by a rinse with clean fresh water. Wipe the Doors dry to prevent any water spotting.

***CAUTION:** Do not use abrasive cleaners on the Doors or you may scratch the glass!!!*

- C. Wipe up any standing water in the bottom of the Proofer and sweep up any solid particles of debris, being careful to keep debris away from the Drain in the floor of the Proofer.
- D. The Proofer interior should be cleaned on a regular basis (at least once a week) with mild soap and hot water followed by a thorough rinse with clean fresh water and a sanitizing agent; wiping the interior dry will help to prevent water spotting. Water spotting and other mineral deposits should be removed with any mild mineral removal agent as soon as they are noticeable.
- E. The Proofer Drain can be cleaned with a small tubular or round brush and hot soapy water, followed by a mild sanitizing agent. If you have drain plumbing attached to the Proofer Drain you can flush the drain line with hot soapy water, followed by a sanitizer. If you do not have any drain plumbing attached, remember to empty and clean any pan or tray used under the Drain. Replace the pan before using the Proofer again.
- F. Leave the Proofer Doors open by about 1" to 2" while the Proofer is not in use.

### **\* \* \* CAUTION \* \* \***

NU-VU® DOES NOT RECOMMEND the use of any strong commercial or caustic product on this equipment. DO NOT allow any type of caustic cleaner to come into contact with any aluminum parts (such as Door Frames) or any of the sealant in the Proofer seams and joints. These caustic cleaners may cause discoloration and/or degradation of these parts, and may result in permanent damage. DO NOT use bleach or bleach compounds on any chromed parts; bleach may damage chrome plating.

# TROUBLE-SHOOTING GUIDE

- I. **The Power Switch is in the ON position but you have no moisture or heat, and the Blower Wheel does not rotate:**
  - A. The Power Switch/Circuit Breaker [11] may be tripped. Set it to the **OFF** position, then back to **ON**.
  - B. Check the main wall breaker or fuse box for a tripped breaker or blown fuse.
  - C. Remove the Outside Top [36] and check the connections from the Power Terminal Block to the Contactor [4] and the Power Switch [11]. All connections must be clean and tight.
  - D. Make sure the voltage of your power supply corresponds to the label on the side of your equipment.
  - E. If all electrical readings are correct (voltage and phase) and all connections are clean and tight you must replace the Power Switch (refer to *POWER SWITCH, How to Replace* in the *SERVICE AND REPLACEMENT GUIDE*).
  
- II. **The Power Switch is in the ON position and you have Blower Wheel rotation and moisture but no heat:**
  - A. Make sure the Temperature Control [14] is set above room temperature.
  - B. Check the Heating Elements [5] behind the Sidewalls [24] of the Proofer (the Elements can be accessed by removing the Element Cover [21] in the ceiling of the Proofer). They should get very hot to the touch as soon as the Temperature Control is activated.
  - C. Check the electrical connections from the Power Terminal Block to the Power Switch, to the Temperature Control and to the control coil on the Contactor. Check the electrical connections from the Power Terminal Block to the Contactor input terminals and from the Contactor output terminals to the Heating Elements. All connections must be clean and tight.
  - D. Check the voltage from the power supply to the Power Terminal Block, to the Power Switch and to the Temperature Control, and from the Power Terminal Block to the Contactor and the Heating Elements. The voltage should correspond to the label listing on the side of your equipment. If voltage is present at the Heating Elements one or more of the Heating Elements may be burned out. If voltage is present at the input side of the Temperature Control but not at the output side the Temperature Control or Temperature Control Sensor [16] may be bad.
  - E. Check the Temperature Control Sensor for any damage. Any damage to the Sensor or its capillary tube will require replacement of the entire Temperature Control.

- F. Check the Temperature Control for proper calibration. Place an accurate thermometer in the center of the PROW-18. Turn the Humidity Control [17] to **OFF** and the Temperature Control to 100°. Read the thermometer when the Temperature Control Indicator Light [15] goes out. If there is more than a 5° difference between the control setting and the thermometer reading the Temperature Control may need a simple dial adjustment (refer to *TEMPERATURE CONTROL, How to Adjust* in the *SERVICE AND REPLACEMENT GUIDE*).

***IMPORTANT:*** Please call NU-VU®'s Service Department before you attempt to recalibrate any Controls!

**III. The Power Switch is in the ON position and you have Blower Wheel rotation and heat but no moisture:**

- A. Check for adequate and sustained pressure in the water supply line to the Proofer up to the Solenoid Valve [8]. If there is sufficient pressure at the water source but not at the Solenoid Valve the in-line water filter may be clogged or the water supply line may be kinked or pinched.
- B. Tap the Solenoid Valve to loosen and dislodge any sediment that may be stuck in the inlet or outlet, or is causing the Solenoid Valve to stick.
- C. Remove the Proofer Element Cover [21] to expose the Humidity Injection Nozzles [23]. Unscrew each Injection Nozzle head and check for clogging in the spray orifice. Clean the internal screen with a small brush before re-assembly.
- D. Check all electrical connections between the Proofer Power Switch, Humidity Control, Repeat Cycle Timer [7] and the Solenoid Valve. All connections must be clean and tight.
- E. Check the Humidity Control, Repeat Cycle Timer and the Solenoid Valve with a voltmeter for proper operation. Any suspect component should be thoroughly examined. All non-functional components must be replaced.

**IV. The Power Switch is in the ON position but the Proofer Motor makes noise or does not run:**

- A. Loosen the Element Cover [22] and pull it away from the Motor Blower Wheel [22]. If the Proofer Motor [6] starts running, or the noise stops, the Blower Wheel was dragging on the Element Cover. Straighten the Element Cover (if it is bent) or reposition the Blower Wheel on the Motor shaft.
- B. Check the Blower Wheel for dragging on the ceiling of the Proofer. Reposition the Blower Wheel on the Motor shaft as necessary.
- C. If the Blower Wheel is not dragging on the Element Cover or the Proofer ceiling but still makes excessive noise the Blower Wheel may be loose on the Motor shaft. Check the screws on the Blower Wheel and the Motor Mount for tightness (refer to *MOTOR/BLOWER WHEEL ASSEMBLY, How to Replace* in the *SERVICE AND REPLACEMENT GUIDE*).

- D. If the Blower Wheel is not dragging on anything but turns hard when you spin it by hand the Motor bearings are probably bad and the Motor must be replaced (refer to *MOTOR/BLOWER WHEEL ASSEMBLY, How to Replace* in the *SERVICE AND REPLACEMENT GUIDE*).
- E. If the Blower Wheel is not dragging on anything and turns easily when you spin it by hand:
  - 1. Check all electrical connections between the Power Switch [11] and the Proofer Motor. All connections must be clean and tight.

*NOTE: It may be necessary to remove the Proofer Motor Assembly for inspection (refer to MOTOR/BLOWER WHEEL ASSEMBLY, How to Replace in the SERVICE AND REPLACEMENT GUIDE).*

- 2. Check for voltage from the Power Switch to the Motor. If voltage is present but the Motor fails to run the Motor must be replaced (refer to *MOTOR/BLOWER WHEEL ASSEMBLY, How to Replace* in the *SERVICE AND REPLACEMENT GUIDE*).

**V. The Proofer Power Switch is in the ON position and one or more Indicator Lights does not light up:**

The Indicator Lights tell when a system or control is activated. Failure of the Indicator Light itself will not affect the operation of your equipment.

- A. Make sure the associated control is activated and working.
- B. Check all electrical connections from the control to the Indicator Light and to the common (WHITE) wire connection. All connections must be clean and tight.
- C. If the connections are good and the associated control functions properly the Indicator Light itself must be replaced (refer to *INDICATOR LIGHT, How to Replace* in the *SERVICE AND REPLACEMENT GUIDE*).

# SERVICE AND REPLACEMENT GUIDE

Your NU-VU® PROW-18 Proofer has been designed to be serviced quickly and easily. In fact, any individual who has average mechanical ability can do the work. Our Service Department is also available to you Monday through Friday from 7:00 a.m. to 5:30 p.m. (Central Standard Time) should you find yourself with a situation or problem other than what is outlined here. Call NU-VU® at (800) 338-9886 and ask for our Service Department to order replacement parts, ask questions, or offer comments.

This *SERVICE AND REPLACEMENT GUIDE* has been prepared to cover most normal service problems. If this "trouble-shooting" information does not provide a solution for your particular problem we ask that you call us for direct assistance. Calling our Service Department before calling in a repair technician can usually save you both time and unnecessary expense. We want to do everything we can to minimize your "down-time".

You may need to remove an Access Panel for servicing. **DO NOT** allow any Access Panels to drop. When work on the component is finished replace the Panel with care, making sure that all wires are properly placed and not pulled or pinched. If more than one component is being worked on try to remove only one component at a time.

**\* \* \* NOTICE \* \* \***

**NATIONAL SANITATION FOUNDATION GUIDELINES REQUIRE THAT ALL INTERIOR PARTS BE REMOVABLE WITHOUT THE USE OF TOOLS. THIS EQUIPMENT HAS BEEN FACTORY ASSEMBLED TO SAFELY ACCOMMODATE ROUGH HANDLING THROUGH SHIPMENT AND ORIGINAL INSTALLATION. AFTER ANY MAINTENANCE, CLEANING OR REQUIRED SERVICE WORK THE INTERIOR SHEET-METAL PARTS SHOULD BE RE-ASSEMBLED AND FASTENED HAND-TIGHT ONLY, BUT STILL REMAIN TIGHT ENOUGH TO PREVENT ANY RATTLE OR MOVEMENT OF PARTS.**

---

## POWER TERMINAL BLOCK OR CONTACTOR, How To Replace:

The Power Terminal Block [1] or Contactor [4] very seldom requires replacement. However, should either one ever become damaged or defective in any way a qualified electrician or service technician should be called in and NU-VU®'s Service Department notified immediately.



**WARNING: IMPROPER REPLACEMENT OR INSTALLATION MAY CAUSE SEVERE EQUIPMENT DAMAGE OR PERSONAL INJURY, AND MAY ALSO VOID ALL OR PART OF YOUR NU-VU® EQUIPMENT WARRANTY!!!**

**MOTOR/BLOWER WHEEL ASSEMBLY, How To Replace:**

MAKE SURE ALL POWER TO THE UNIT IS OFF. FAILURE TO DO SO MAY CAUSE SEVERE EQUIPMENT DAMAGE OR PERSONAL INJURY!

- A. Remove the Element Cover [21] in the ceiling of the unit to expose the Blower Wheel [22]. Loosen the set screws on the Blower Wheel hub and remove the Blower Wheel from the Motor shaft.
- B. Remove the Outside Top [36] of the PROW-18 to expose the Motor Assembly. Remove the four bolts holding the Motor Assembly [6] in place.
- C. Label and disconnect the Motor wiring and remove the Motor Assembly from the Proofer.
- D. Lower the replacement Motor Assembly into place and fasten it securely with the mounting bolts.
- E. Connect the electrical leads to the new Motor Assembly. Make sure all connections are clean and tight.
- F. Replace the Blower Wheel on the Motor shaft. Tighten the set screws securely; a loose Blower Wheel will cause a later service problem.
- G. Restore electrical power to the unit and test the new Motor/Blower Wheel Assembly for proper operation. Make sure the Blower Wheel does not drag on the ceiling of the Proofer.
- H. Replace the Element Cover and retest the Motor/Blower Wheel Assembly. Make sure the Blower Wheel does not drag on the underside of the Element Cover.

**HEAT ELEMENT, How To Replace:**

MAKE SURE ALL POWER TO THE UNIT IS OFF. FAILURE TO DO SO MAY CAUSE SEVERE EQUIPMENT DAMAGE OR PERSONAL INJURY!

- A. Remove the ceiling Element Cover [21] and the right or left Sidewall [24] to expose the affected Heat Element [5].
- B. Remove the Outside Top [36] of the unit to access the wiring connections on the defective Heat Element.
- C. Trace the Heat Element wiring back to the Contactor [4] and/or Power Terminal Block [1]. Label the connection points and disconnect the Heat Element wires.
- D. Remove the defective Heat Element from its mountings and pull it straight out from the side of the Proofer. Clean away any old sealant around the mounting holes or wire passage holes in the Proofer.
- E. Start the replacement Element wires through the passage holes in the ceiling of the Proofer, position the replacement Heat Element and secure it into place with the mounting screws.
- F. Reconnect the electrical wires as labeled. All connections must be clean and tight.
- G. Restore electrical power to the unit and test the replacement Heat Element for proper operation.
- H. Replace the Sidewall, Element Cover and Outside Top. Be careful not to pull or pinch any wires when replacing these Panels.

## TEMPERATURE CONTROL, How To Adjust:

PLEASE CALL NU-VU®'S SERVICE DEPARTMENT AT (800) 338-9886 BEFORE ATTEMPTING TO ADJUST THE TEMPERATURE CONTROL!!!

- A. Place a reliable thermometer (or the thermocouple of a test instrument) on a pan in the center of the Proofer. Set the Power Switch [11] to **ON**, the Humidity Control [17] to **OFF** and the Temperature Control [14] to its normal setting. Allow the equipment to reach a stable operating temperature.
- B. Compare the Temperature Control setting to the reading on the test instrument. If there is a difference of more than 20°F you will probably need to replace the Temperature Control and its Sensor [16]. Please refer to the appropriate instructions for the *TEMPERATURE CONTROL AND SENSOR, How To Replace*.
- C. If the difference is less than 20°F a simple dial adjustment may solve the problem:
  1. Remove the Knob of the Temperature Control by pulling it straight out from the face of the unit.
  2. Hold the knurled black center of the Knob securely with the back of the clear plastic dial toward you. Use a phillips screwdriver to loosen the two screws from  $\frac{3}{4}$  to 1 full turn, *but do not remove them!*
  3. To increase the temperature inside the Proofer carefully rotate the index line on the clear dial *clockwise* as you view it from the back. Each "click" on the 250° dial is equal to approximately 3-4° of change. To decrease the inside temperature rotate the clear dial *counter-clockwise*.
- D. Gently tighten the dial screws and install the Knob. Check the Temperature Control setting against the test instrument and repeat this procedure if necessary.
- E. If this procedure fails to bring the temperature reading within the desired specs you will have to replace the Temperature Control and Sensor.

## TEMPERATURE CONTROL, How To Replace:

MAKE SURE ALL POWER TO THE UNIT IS OFF. FAILURE TO DO SO MAY CAUSE SEVERE EQUIPMENT DAMAGE OR PERSONAL INJURY!

- A. Remove the Outside Top [36] of the PROW-18 to expose the back side of the Temperature Control [14] and its wiring connections along with the Sensor [16] tube.
- B. Remove the Control Knob by pulling it straight out from the face of the Control Panel.
- C. Remove the two mounting screws holding the Temperature Control to the front of the Panel and pull the Control out from behind the Panel.
- D. Label all electrical connections and disconnect the wiring at the Temperature Control.
- E. Follow the Sensor tube from the Temperature Control to the Sensor Mounting Bracket in the top of the PROW-18. This Bracket is a small square plate screwed down next to the Motor Assembly. Remove the screws holding the Bracket in place and break the Bracket free from the sealant. Remove the Temperature Control Sensor from the Mounting Bracket.

- F. Position the replacement Temperature Control behind the Control Panel and secure it in place with the two mounting screws. Seat the mounting screws firmly *but do not over-tighten!*
- G. Attach all electrical wiring as labeled. Make sure all connections are clean and tight.
- H. Gently uncoil the new Control Sensor and its tubing, *using extreme care not to kink or damage it in any way!* Attach the Temperature Control Sensor to the Mounting Bracket and fasten the Bracket in place. Carefully position any excess Sensor tubing away from any possible electrical contact. Seal around the exterior edges of the Bracket with any high-quality silicone sealant. Also seal the Sensor passage hole in the Bracket.

***NOTE:** The Sensor's capillary tube is fragile; use extreme care not to damage it in any way during the replacement procedure.*

- I. Replace the Outside Top. Be careful not to pull or pinch any wires when replacing this Panel.
- J. Restore electrical power to the unit and test the replacement Control for proper operation. We recommend that any replaced Temperature Control be checked for proper adjustment (refer to *INITIAL START-UP* and *TEMPERATURE CONTROL, How To Adjust*).

### **HUMIDITY CONTROL, How to Replace:**

**MAKE SURE ALL POWER TO THE UNIT IS OFF. FAILURE TO DO SO MAY CAUSE SEVERE EQUIPMENT DAMAGE OR PERSONAL INJURY!**

- A. Remove the Outside Top [36] of the PROW-18 to expose the back side of the Humidity Control [17] and its wiring connections.
- B. Remove the Knob from the Humidity Control by pulling it straight out from the front of the Control Panel.
- C. Remove the mounting screws from the Humidity Control and pull the Humidity Control from the back of the Control Panel.
- D. Label and disconnect all electrical wiring to the Humidity Control.
- E. Position the replacement Humidity Control on the back of the Control Panel and secure it in place with the two mounting screws. Reinstall the Humidity Control Knob by pressing it onto the end of the Control shaft.
- F. Attach the electrical wiring to the replacement Control as labeled. All connections must be clean and tight.
- G. Replace the Outside Top. Be careful not to pull or pinch any wires when replacing the Panel.
- H. Restore electrical power to the unit and test the replacement Humidity Control for proper operation.

**TIMER, How to Replace:**

MAKE SURE ALL POWER TO THE UNIT IS OFF. FAILURE TO DO SO MAY CAUSE SEVERE EQUIPMENT DAMAGE OR PERSONAL INJURY!

- A. Remove the Outside Top [36] to expose the 60-Minute Timer [13] and its wiring connections.
- B. Remove the Timer Knob by pulling it straight out from the front of the Control Panel.
- C. Remove the two screws securing the Timer to the Control Panel and pull the Timer out from the back of the Control Panel.
- D. Label and disconnect the Timer wiring, OR disconnect the wires one at a time and transfer each one to the same location on the replacement Timer: Terminal "6" on the back of the Timer should be connected to the Power Switch. Terminal "4" on the back of the Timer should be connected to either terminal on the Buzzer Alarm [9]. Make sure all connections are clean and tight.
- E. Position the replacement Timer on the back of the Control Panel and secure the Timer in place with the two mounting screws. Re-install the Timer Knob by pressing it onto the end of the Timer shaft.
- F. Replace the Outside Top. Be careful not to pull or pinch any wires when replacing the Panel.
- G. Restore electrical power to the unit. Test the 60-Minute Timer by setting the Timer Knob at 5 minutes and letting the Timer count down. The Buzzer Alarm should sound when the Timer reaches 0.

*NOTE: The index mark on the Timer Knob can be adjusted by loosening the two phillips-head screws on the back of the Knob, repositioning the clear plastic dial, and tightening the screws.*

**BUZZER ALARM, How to Replace:**

MAKE SURE ALL POWER TO THE UNIT IS OFF. FAILURE TO DO SO MAY CAUSE SEVERE EQUIPMENT DAMAGE OR PERSONAL INJURY!

- A. Remove the Outside Top [36] to expose the Buzzer Alarm [9] and its wiring connections.
- B. Remove the screw or screws securing the Buzzer Alarm in place and pull the Buzzer from the top of the unit.
- C. Label and disconnect the Buzzer wiring, OR disconnect the wires one at a time and transfer them to the same locations on the replacement Buzzer. Make sure all connections are clean and tight.
- D. Position the replacement Buzzer on top of the unit and secure it in place with the mounting screw or screws.
- E. Replace the Outside Top. Be careful not to pull or pinch any wires when replacing the Panel.
- F. Restore electrical power to the unit and test the Buzzer for proper operation.

**REPEAT CYCLE TIMER, How To Replace:**

MAKE SURE ALL POWER TO THE UNIT IS OFF. FAILURE TO DO SO MAY CAUSE SEVERE EQUIPMENT DAMAGE OR PERSONAL INJURY!

- A. Remove the Outside Top [36] of the PROW-18 to expose the Repeat Cycle Timer [7] and its electrical connections.
- B. Locate the Repeat Cycle Timer mounted on the top of the unit near the front of the Proofer. Label and disconnect all wiring to the Repeat Cycle Timer.
- C. Remove the slotted mounting screw in the center of the Repeat Cycle Timer and remove the Timer from the unit.
- D. Insert the mounting screw through the center of the replacement Repeat Cycle Timer and fasten the Timer to the mounting bracket. *Do not over-tighten* the mounting screw or you may crack the Timer's plastic case.
- E. Reconnect all electrical wiring as it is labeled. All connections must be clean and tight.
- F. Replace the Outside Top. Be careful not to pull or pinch any wires when replacing the Panel.
- G. Restore electrical power to the unit and test the Repeat Cycle Timer and Humidity Control for proper operation.

**WATER SOLENOID VALVE, How to Replace:**

MAKE SURE ALL POWER TO THE UNIT IS OFF. FAILURE TO DO SO MAY CAUSE SEVERE EQUIPMENT DAMAGE OR PERSONAL INJURY!

- A. Locate and turn OFF the water supply to the Proofer.
- B. Remove the Outside Top [36] of your unit to expose the Water Solenoid Valve [8] along with its plumbing and wiring connections.
- C. Locate the Water Solenoid Valve, an odd-shaped red, green and brass plumbing fixture. The AUTOMIST Solenoid Valve should be mounted on a structural frame member toward the back of the unit. Label and disconnect the electrical wiring to the Solenoid Valve.
- D. Loosen the copper tubing connections to the Solenoid Valve body and remove the plumbing from the Solenoid Valve.

*NOTE: Place a towel or other absorbent material under the Solenoid Valve to catch any water that may drain from the disconnected plumbing. Protect all electrical components in the area.*

- E. Remove the Solenoid Valve mounting screws and remove the Solenoid Valve from the Proofer.

*IMPORTANT: Make note of the flow direction before removing the Solenoid Valve.*

- F. Position the replacement Solenoid Valve in the Proofer and secure it in place. Make sure the *flow direction* as marked on the Solenoid Valve body is the same as that observed in STEP "E".

- G. Position the plumbing connections at the Solenoid Valve body and snug them into place, *but do not over-tighten!* If the joint leaks when tested and further tightening does not stop the leak the fitting must be replaced. If "pipe dope" is used to create a leak-free joint use care not to get any "pipe dope" in the plumbing itself. Any excess may be flushed through the plumbing and cause a Solenoid Valve to stick or clog an Injection Nozzle [23].
- H. Reconnect the electrical wiring as labeled. Make sure all connections are clean and tight.
- I. Restore the water supply to the unit. Check for plumbing leaks on the intake side of the Solenoid Valve.
- J. Restore electrical power to the unit and activate the Humidity Control [17]. Check the Solenoid Valve for proper operation and the plumbing for leaks on the outlet side of the Solenoid Valve.
- K. Replace the Outside Top. Be sure not to pull or pinch any wires when replacing the Panel.

### **COOLING FAN ASSEMBLY, How to Replace:**

MAKE SURE ALL POWER TO THE UNIT IS OFF. FAILURE TO DO SO MAY CAUSE SEVERE EQUIPMENT DAMAGE OR PERSONAL INJURY!

- A. Remove the Outside Top [36] to expose the Control components and their wiring connections.
- B. Remove the four mounting screws holding the Cooling Fan Assembly [10] in place and remove the Cooling Fan.
- C. Disconnect the defective Cooling Fan from the unit wiring and connect the replacement Cooling Fan.
- D. Position the replacement Cooling Fan with the Finger Guard and fasten them in place with the four mounting screws.
- E. Replace the Outside Top. Be careful not to pull or pinch any wires when replacing the Panel.
- F. Restore electrical power to the unit and test the Cooling Fan for proper operation.

### **POWER SWITCH, How To Replace:**

MAKE SURE ALL POWER TO THE UNIT IS OFF. FAILURE TO DO SO MAY CAUSE SEVERE EQUIPMENT DAMAGE OR PERSONAL INJURY!

- A. Remove the Outside Top [36] of the Proofer to expose the back side of the Power Switch [11] and its wiring connections.
- B. Label and disconnect all wires to the defective Power Switch.
- C. Remove the Power Switch by depressing the spring locking tabs on the top and bottom of the Switch frame where it passes through the Control Panel. The Switch should now exit through the front of the Panel.

***NOTE:** The replacement Power Switch (Circuit Breaker) must be installed so that the Breaker toggle is in the UP position when the Circuit Breaker is set to ON.*

- D. Reconnect the wires as tagged. The wire at the bottom Switch terminal should come from the Power Terminal Block [1]. The wire at the top terminal should lead to a wire nut junction. Make sure all connections are clean and tight.
- E. Replace the Outside Top. Be careful not to pull or pinch any wires when replacing the Panel.
- F. Restore electrical power to the unit and test the Power Switch and its related controls for proper operation.

### INDICATOR LIGHT, How To Replace:

MAKE SURE ALL POWER TO THE UNIT IS OFF. FAILURE TO DO SO MAY CAUSE SEVERE EQUIPMENT DAMAGE OR PERSONAL INJURY!

The Indicator Lights tell when a system or control is activated. Failure of the Indicator Light itself will not affect the operation and performance of your equipment.

- A. Remove the Outside Top [36] of the unit to expose the back side of the Indicator Lights and their wiring connections.
- B. Tag and disconnect the wires on the defective Indicator Light.
- C. Remove the defective Indicator Light by pushing it out through the front of the Control Panel.
- D. Install the replacement Indicator Light, wires first, from the front of the Panel until the metal collar on the Indicator Light is tight against the front of the Panel.
- E. Refasten the wire connections. Make sure all connections are clean and tight.



**WARNING: DO NOT PULL ON THE INDICATOR LIGHT WIRES WHILE INSTALLING THE INDICATOR LIGHT!!!**

- F. Replace the Outside Top. Be careful not to pull or pinch any wires when replacing the Panel.
- G. Restore electrical power to the unit and test the Indicator Light and its associated Controls for proper operation.

### DOOR LATCH, How To Replace:

- A. Loosen the two acorn nuts inside the Latch Cover [34] with a  $\frac{1}{2}$ " box or open-end wrench. Pull the Latch Cover straight out from the Oven Door [31] to remove it and remove the two acorn nuts.
- B. Loosen and remove the screws securing the Door Latch [33] to the Latch Bracket. Remove the Door Latch and its Adjustment Plate.
- C. Position the replacement Door Latch on the Latch Bracket. Align the holes in the Adjustment Plate with the holes in the Door Latch body and secure the Adjustment Plate and Door Latch to the Latch Bracket.
- D. Adjust the replacement Door Latch to obtain proper Door sealing and closure (refer to *DOOR LATCH, How To Adjust*). Tighten the mounting screws securely.

- E. Install the acorn nuts on the ends of the top and bottom Door Latch screws. Turn the nuts on all the way until they just contact the back side of the Latch Bracket, then loosen them by 1½ to 2 full turns. Install the Latch Cover and tighten the acorn nuts lightly to hold the Latch Cover in place.

### **DOOR LATCH CATCH PLATE, How To Replace:**

- A. Mark the outline of the Catch Plate on the face of the unit. Remove the two Catch Plate mounting screws and remove the Catch Plate.
- B. Place the replacement Catch Plate on the face of the unit in the same position as the original.
- C. Fasten the Catch Plate in place with the two mounting screws. Tighten them securely.

### **DOOR LATCH, How To Adjust:**

Determine if a Proofer Door [31] is fitting too loose (it will leak heated air past the Door Gasket [35]) or too tight (it will not close properly). If it is too loose the Door Latch [33] must be adjusted OUT (away from the unit). If it is too tight the Door Latch must be adjusted IN (towards the unit). Please proceed as follows:

- A. Loosen the two acorn nuts inside the Latch Cover [34] with a 3/8" wrench. Pull the Latch Cover straight out from the Oven Door to remove it and remove the acorn nuts.
- B. Open the Door and take careful notice of the Adjustment Plate position against the body of the Door Latch.
- C. Hold the Adjustment Plate against the body of the Door Latch with one hand while you loosen the mounting screws with the other hand. Back the screws out approximately three full turns.
- D. Carefully move the Latch Body IN or OUT under the Adjustment Plate one notch at a time. Make sure the Door Latch stays straight up and down and tighten the mounting screws. Test the Door for proper closing and sealing (refer to the *DOOR TEST PROCEDURE*).
- E. Repeat steps "C" and "D" if you are not satisfied with the Door adjustment. If the Door tests as satisfactory make sure the mounting screws are tightened securely.
- F. Install the acorn nuts on the ends of the top and bottom Door Latch screws. Turn the nuts on all the way until they just contact the back side of the Latch Bracket, then loosen them by 1½ to 2 full turns. Install the Latch Cover and tighten the acorn nuts lightly to hold the Latch Cover in place.

### **DOOR TEST PROCEDURE:**

- A. Cut one or two strips of paper approximately 1" wide and 8" to 10" long.
- B. Open the Door slightly, insert a strip of paper between the Gasket and Jamb and close the Door.
- C. Slowly pull the paper strip out. You should feel light to moderate resistance as you pull the strip from between the Gasket and Jamb of a properly adjusted Door. Test the fit at regular 2" to 3" intervals around the entire Door.

- D. If you feel **NO** resistance at a particular spot the Door is too loose, you have found a weak or damaged spot in the Door Gasket [35] or the Jamb has been bent in.
- E. If you feel **HEAVY** resistance at a particular spot the Door is too tight or the Jamb has been bent out.

### **HINGES, How To Adjust:**

Hinges on flush-mount Doors are preset at the factory and should not need adjustment. However, if you experience any problems with Door operation please call NU-VU®'s Service Department at (800) 338-9886 for assistance.

### **HINGES, How To Replace:**

- A. Open the Oven Door [31] until it is straight out (perpendicular) from the face of the unit. Lift the Door straight up and off of the Door Hinge [32] pins.
- B. Remove the bottom half of each Hinge (with the pivot pin) from the unit. Replace with the identical part from the new Hinge. Make sure the pivot pin points up and that the screws are fully seated and tight.
- C. Remove the top half of each Hinge from the Door. Replace with the identical part from the new Hinge. Make sure that the screws are fully seated and tight.
- D. Make sure that any washers provided with each replacement Hinge are installed on the pivot pin between the Hinge halves. Position the Door so that the sleeve of the top half of each Hinge is centered over the end of the pivot pin on the bottom half of each Hinge. Lower the Door onto the pivot pins. Work the Door back and forth to fully seat the Hinges.
- E. Test the Door for proper closing and sealing (refer to the *DOOR TEST PROCEDURE*).

### **DOOR GASKET, How to Replace:**

Follow these instructions to correctly install your Door Gasket with minimal problems. Use the installation kit provided. If you have any problems or questions call NU-VU® at (800) 338-9886. Ask for the Service Department.

- A. Remove all pieces of the old Gasket. Thoroughly clean the Door frame in the area of the new installation. Remove the old sealant and any baked-on deposits.
- B. Pre-cut the replacement Gasket to a size slightly longer than you require.



**IMPORTANT: DO NOT DISASSEMBLE THE ACTUAL DOOR FRAME WHEN REPAIRING OR REPLACING THE DOOR GASKET!!!**

- C. Put a small amount of soap water into and around the slot that the new Gasket will fit into (a small trigger spray bottle works well). This step is optional but will help in the installation.

- D. Position the new Gasket over the slot, allowing the ends to extend past the end of the slot. Press the mounting flange down into the slot on the Door frame. Use a roller tool to force the mounting flange into the slot by working the tool back and forth along the Gasket. Make sure the Gasket mounting flange is completely fitted into the slot and that the Gasket is free to slide back and forth in the slot.
- E. Use a sharp knife or a single-edged razor blade to cut the ends of the Gasket at a 45° angle (you can use the mitered corner joint on the Door as an angle guide). Cut the Gasket about 1/4" longer than the required length and work the excess back into the slot. This extra Gasket will help to create a nice tight corner joint, and allows for any follow-up trimming that may be necessary.



**IMPORTANT: DO NOT STRETCH OR PULL ON THE GASKET DURING THE INSTALLATION PROCESS. THIS WILL LATER CAUSE THE TRIMMED CORNERS TO SEPARATE AND PULL APART!!!**

- F. Work your way around the entire Door (or the section of the Door having the Gasket replaced). Make sure the Gasket is just tight into the corners. A bulging joint or pucker along the Gasket indicates a Gasket section that is cut too long. Joints that pull apart indicate a Gasket section (or sections) that is cut too short.
- G. Seal the corner joints after the entire Gasket is properly fitted. Pull the joints apart only enough to put sealant on all the *cut edges only*. Allow the Gasket joint to come together. Smooth out any excess sealant to form a smooth surface on the face of the Gasket. Add more sealant to any spots as necessary and smooth them down.



**IMPORTANT: MAKE SURE THAT THE GASKET AND DOOR FRAME ARE COMPLETELY CLEAN AND DRY BEFORE APPLYING ANY SEALANT!!!**

- H. A quality sealant will be dry to the touch and tack-free in one to two hours after application. However, it will not be completely cured until six to eight hours later. We recommend that you wait until after your sealant is completely cured before using your Oven.



**WARNING: SOME SEALANTS GIVE OFF ACIDIC FUMES AS THEY CURE. THESE FUMES MAY CAUSE IRRITATION TO THE EYES AND/OR NASAL PASSAGES. USE CAUTION WHEN OPENING YOUR UNIT AFTER WAITING FOR ANY FRESH SEALANT TO SET UP AND CURE!!!**

## CASTER, How To Replace:

MAKE SURE ALL POWER TO THE UNIT IS OFF. FAILURE TO DO SO MAY CAUSE SEVERE EQUIPMENT DAMAGE OR PERSONAL INJURY!

The Casters [39] on this unit are maintenance free. However, it is occasionally necessary to replace one or more due to shipping damage or improper handling. This can be done either by laying the entire unit on its back or by lifting the unit off of the floor by one or two inches.

### TO LAY UNIT DOWN:

- A. Disconnect any service lines (electrical or water) to the unit.
- B. Move the unit to a level surface that provides a good work area.
- C. Engage all Caster locks.
- D. Remove any unnecessary weight from the unit such as pans, trays and shelves. Even the Doors can be lifted off if you so desire.
- E. Place a 2x4, stacked lumber or any similar item **BEHIND** the rear Casters and immediately under the back bottom edge of the unit. Have another piece handy to place under the top of the unit.
- F. With plenty of help and extreme care gently tilt the unit back onto the spacer behind the Casters and lower it to the floor. Allow it to rest on the second spacer (keep this spacer as close to the top of the unit as possible to avoid damage to the outside back, but beware of the Water Intake Fitting).
- G. Complete the repair and reverse this procedure to stand the unit upright. It is a wise precaution to station someone in front of the unit while it is being raised to prevent the unit from skipping out at the bottom.

### TO LIFT UNIT:

- A. Disconnect any service lines (electrical or water) to the unit. Move the unit to an area enabling you to reach the Caster to be replaced.
- B. Engage all Caster locks.
- C. With a small jack, or using the lever and fulcrum method (such as a length of board and a small wooden block) gently lift the affected side of the unit until the Caster is clear of the floor (1" is sufficient). Shim or block the bottom of the unit to hold it up and remove the lifting device. Lift and repair one side at a time.
- D. Complete the repair and reverse this procedure to lower the unit to the floor.



**IMPORTANT: LIFT AND REPAIR FROM THE FRONT OR BACK ONLY, WITH THE DOORS FIRMLY CLOSED OR REMOVED. DO NOT LIFT FROM THE SIDES. THE UNIT MAY OVER-BALANCE AND TIP OVER!!!**

### TO REPLACE CASTER:

- A. Remove all weight from the affected Caster.
- B. Use a 7/16" wrench or socket to remove the four Caster mounting bolts. Remove the defective Caster.
- C. Position the replacement Caster under the unit base and insert the mounting bolts. Tighten the mounting bolts securely.

# REPLACEMENT PARTS LIST

(PROW-18)

Reference # Description

Replacement Part #

## ELECTRICAL COMPONENTS:

1	Power Terminal Block .....	50-0237
2	Ground Lug .....	50-0062
3	Thermal Overload Safety .....	66-1016
4	Contactor 120v .....	66-2013
	240v.....	66-2017
5	Heating Element, 120v 1000w (wired in series for 240v) .....	60-0044-H(side elements)
6	Motor Assy w/ Blower Wheel .....	250-1050
7	Repeat Cycle Timer 120v .....	66-8012
	240v.....	66-8065
8	Water Solenoid Valve 120v .....	50-0308-1
	240v.....	50-0307-1
9	Buzzer Alarm 120V OR 240v(retrofit).....	252-1024
10	Cooling Fan Assembly, 3" 120v .....	50-0666
	240v.....	

## CONTROL COMPONENTS:

11	Power Switch Black Breaker Style .....	252-6001
12	Timer	
	60-Minute Mechanical (120V, 60Hz).....	252-1004
	60-Minute Mechanical (220V, 60Hz).....	252-1019
	60-Minute Mechanical (230V, 50Hz).....	252-1020
	Timer Knob .....	253-2002
14	Temperature Control (Mechanical Thermostat) .....	252-4004
	Temperature Control Knob (Mech.) .....	50-0727
	Temperature Control (Solid State Thermostat).....	252-4001
	Temperature Control Knob (Solid State).....	253-2003
	Temperature Sensor (Solid State).....	252-3001
15	Temperature Control Indicator Light 120v .....	50-0029-A
	240v.....	50-0030
17	Humidity Control .....	252-3003
	Humidity Control Knob .....	253-2003
18	Humidity Control Indicator Light 120v .....	50-0029-A
	240v.....	50-0030
	Drain Plug Assembly.....	101-0232

## INTERIOR COMPONENTS:

22	Motor Assy w/ Blower Wheel .....	250-1050
23	Water Injection Nozzle .....	31-0033
27	Light Fixture:	
	Socket, Globe, Gasket .....	252-7006
28	Top Wall Assembly.....	130-9072
29	Bottom Wall Assembly .....	130-9073

EXTERIOR COMPONENTS:

31	Door:	
	Left/Right Hinge Door Glass .....	130-9031
	Left/Right Hinge Door Solid.....	130-9054
32	Hinge:	
	Left Hinge .....	254-3011
	Right Hinge .....	254-3012
33	Door Latch/Catch .....	254-2007
35	Door Gasket .....	254-1001
38	Water Inlet Fitting .....	31-0058
39	Caster .....	50-0058
40	Drain Pan .....	50-0547