



-AGUILA-

AG420PRO

EN User Manual

Content

Safety precautions	3
Signals, signal words and safety guidelines	5
Machine overview	6
Refrigerator overview	7
Operating overview	8
Nespresso Grand Cru recommendation	10
First use	11
Energy save mode / Maximum energy save mode	13
Coffee preparation	14
Milk based coffee recipes	16
Milk preparation.....	18
Hot water preparation	19
Daily cleaning	20
Milk froth settings	23
Menu settings	24
Alarms	25
Specifications	28
EC-Declaration	31

Information



Additional information with advice for preparing beverages or machine operation.



CAUTION: Please read these instructions and safety precautions before operating the appliance.

Safety precautions

Please note!

Please read these instructions before starting up the machine.

Please make sure to read these safety instructions carefully before using your coffee machine for the first time. Store these instructions in a safe place where you can refer to them as needed. Improper use of the machine releases *Nespresso*® from any liability.

General safety instructions

- In the event of an emergency, switch off the machine using the main switch. Unplug the machine or remove the fuse from the fuse box. Contact your service partner.
- The machine is for indoor use only.
- The coffee, milk and water spouts may get very hot. Avoid direct contact (risk of burns and scalding)!
- Clean the machine before taking it out of service for a longer period of time (day off, company holiday, etc.). Remove and empty the capsule container, then disconnect the machine from the mains. Remove and empty the milk container, clean it and store it with the lid open. Leave the refrigerator door open to facilitate air circulation.
- Do not use the machine if it is not in perfect working order or if it appears to be damaged. If the machine malfunctions or is damaged, please contact your service partner.
- Never immerse the machine, cable, or plug in water or any other liquid.
- The machine must only be operated in a hygienic and ergonomic environment. The user must have sufficient space and the workstation must be well lit.
- Do not reach up inside the inner casing when the capsules container is removed.
- Children should not be permitted to use this appliance without the supervision of an adult.
- Keep children and other people away from the machine while carrying out repair work. Distractions can cause accidents.

Positioning the machine

- The machine must only be set up and installed, relocated or removed by an authorized and trained service partner of Thermoplan.

- Do not position the machine in warm or moist areas. The ambient temperature must be between 16 °C and 32 °C.
- Never position the machine on a hot surface. Using the machine near open flames is strictly prohibited.
- Position the machine on a flat, horizontal, stable and heat-resistant surface.
- Do not install the machine in an area where a water jet could be used to clean the machine.
- Do not position cable near or on hot parts of the machine. Protect the cable from heat sources and any sharp edges.
- The machine and its supply cables must be positioned out of the reach of children.
- The coffee machine must be free-standing so that the air circulation is not impaired. Therefore leave a gap of at least 50 mm in front of air vents.
- For temporary storage: Store the machine in a dust-free and dry environment. The temperature must never fall below 0 °C!
- Please place this product 20 cm or more from the body of the user or nearby person.

Installation / Transport / Deinstallation

- The machine must only be installed, relocated to another location or removed by authorized and trained service partners of Thermoplan. Be aware and adhere to national weight lifting requirements
- The machine must only be installed using the supplied connection cables and hoses. Any existing cables or hoses must not be reused. The manufacturer is not liable for any damages arising from improper installation. The use of incorrect connections voids warranty!
- The water connection must only be connected to a drinking water supply system.
- Be aware of national requirements for installations to a drinking water supply system
- Check water connections for leaks periodically.
- The voltage quoted on the rating plate must be the same as the mains voltage in your country.
- The top side of the machine must be at least 1.5m above the ground.

Use of the machine

This machine is only suitable for producing coffee, milk and hot water products and is suitable for commercial use in the catering trade. Therefore, please take note of the following instructions:

- This machine works with *Nespresso* capsules, available exclusively through *Nespresso*® and its authorized distributors.
- The milk container must only be used to store cold milk. Do not fill the milk container with any liquids other than milk (e.g. syrup or alcohol). Please note that when pouring the milk into the milk container it must have a temperature of below 5 °C, as the container has been designed to keep the milk cool but not to lower its temperature.
- Carry out all necessary maintenance work as described in these instructions at regular intervals.

Cleaning the machine

Cleaning the machine on a daily basis is not only an absolute must, but it also guarantees the necessary hygiene and neutral taste as well as a longer life of the machine.

Please refer to chapter "Daily cleaning" (page 20) for a complete guide to successfully clean your machine. Also take note of the following instructions:

- Use only the Thermoplan milk cleaning tablets to perform the automatic cleaning process. Do not use any other cleaning detergent or disinfection agent for this purpose.
- When touching the coffee machine, in particular the spouts, bacterial contamination must be avoided.
- Cloths or sponges must be wrung out thoroughly to ensure that they are only moist, not wet, otherwise there is a risk of electric shock.
- Plastic parts must not be dried in the microwave.
- Do not clean plastic parts with alcohol, ethanol, methanol, methylated spirits or disinfectants. Detergents with strong acid agents such as acetic acid must also not be used.
- The machine must not be cleaned with water jets.

Safety precautions

Operation

- The machines must only be operated by trained operator staff.
- All operations other than those mentioned in this manual must only be performed by authorized and trained service partners of Thermoplan.
- Always close the lever completely and never lift it during operation. Do not put fingers into the capsule insertion slots. Danger of injury!
- If a capsule is blocked in the capsule insertion slot, switch off the machine before any operation.
- Do not open lever during preparation. To stop preparation, press the same product button again.
- Never use the machine without the drip grid.
- Keep your workspace clean and tidy. Disorder and unlit workspaces can lead to accidents.
- The capsules container must be emptied when the corresponding notification appears on the display. Rinse the container with a solution of warm, soapy water after you have finished using it.
- This dispensing machine is not intended to be used by persons (including children) with reduced physical, sensory or mental capabilities or with a lack of experience and knowledge unless they were explicitly trained by a responsible person or briefed in the use of the dispensing machine to ensure their safety. Children must be kept away from the machine at all times.

Commercial use

- Aguila AG420PRO is an espresso coffee maker (or machine).
- This appliance is intended to be used by experts or trained users in shops, in light industry and on farms, or for commercial use by lay persons.

Service through the service partner

- A notification will appear on the coffee machine display if the machine needs to be serviced. The machine must be serviced by authorized and trained service partners of Thermoplan at least once every year or every 48'000 product beverages.
- The machine must not be opened by any persons other than authorized and trained service partners of Thermoplan.

Disposal

- An authorized and trained service partner of Thermoplan has to dispose of the machine and its packaging. Do not dispose of the machine or its components yourself.

Limitations of liability

- Thermoplan accepts no liability for any injuries or accidents if the safety instructions covered in this manual are not adhered to. Additionally, liability is only accepted within the boundaries of the machine. Thermoplan shall be liable for faults on the machine in accordance with the warranty regulations.
- The manufacturer cannot be held liable for any damage caused by misuse or inappropriate handling of the machine.

Warranty regulations

- The fee-based full-service extended warranty of Thermoplan shall be fully inclusive of all costs for service or parts for a period of five years from the installation on. Malfunctions due to misuse or connecting unsuitable connections shall not be compensated.
- The Thermoplan manufacturer's warranty shall apply to individual components or assemblies for 12 months from installation or for 15 months after delivery ex works in the event of manufacturing or construction errors. Malfunctions due to misuse or connecting unsuitable connections shall not be compensated. Wear and tear parts are not covered by any warranty. The working time is not covered by the Thermoplan factory warranty. Each warranty claim must be recorded by the corresponding Thermoplan service partner using a fully completed form that is submitted to Thermoplan. Thermoplan reviews the claims, issues RMA numbers to them and informs the affected reseller which spare parts need to be returned.
- All *Nespresso*® machines must pass stringent controls. Reliability tests under practical conditions are performed randomly on selected units. This can show traces of any previous use.

Signals, signal words and safety guidelines



The warning triangle appears in the instructions where non-adherence to the safety instructions may result in risks to the user or the machine.



Warning
Electric shock



Warning
Risk of scalding



Instruction:
Read instructions



General
information



Prohibition:
Do not touch



Prohibition:
Do not reach inside



Instruction:
Wear safety glasses



Instruction:
Wear gloves

Service partner

Your service partner is a Thermoplan representative. If you have any questions or problems, first contact a Nespresso representative.

Trained service staff

Trained service staff are employees trained and certified by Thermoplan, who sell and maintain Thermoplan products.

Trained operator staff

Briefed staff are employees who were briefed and trained in the use of the coffee machine (reading of the instruction manual) and who are able to operate the machine and execute the maintenance steps described in this manual.

Customers and children

Customers and children are not considered briefed persons and must be kept away from the machine at all times.

Dispensing machines

Dispensing machines are devices that can dispense coffee, milk and hot water products.



Electrical safety

Danger of electric shock

- The live parts are located inside the casing of the coffee machine.
- Therefore, do not open the casing under any circumstances. Only trained service staff may open the machine.
- Keep the dispensing machine away from moisture.
- Never pour any type of liquid on top of the machine.
- Stop using the dispensing machine if the cable or plug are damaged. Have the faulty part repaired or replaced.



Service

Risk of injury: Do not carry out any modifications on the machine

- The manufacturer does not accept any liability for consequences arising from both internal and external modifications on the machines.
- Never open the machine to carry out modifications yourself.
- Your dispensing machine should only be repaired by trained service staff and with genuine spare parts. This ensures the safety of the dispensing machine.



Hygiene

Danger of illness through wrong / contaminated food

- Only use food with a sell-by date that has not yet expired.
- Store food in suitable locations.
- Clean the machine periodically and in accordance with the user manual to prevent hygiene risks.
- Only use Thermoplan cleaning accessories!
- Only use heat treated (e.g. pasteurised or ultra heat treated) milk.
- When pouring milk into the container, pay attention to hygiene to ensure that no contaminated milk enters the system.
- Only pour milk that has already been cooled down (below 5°C) into the milk container.
- Once the milk has been opened, use it up within 24 hours to prevent health hazards.



Potential safety hazards

Risk of scalding from the spouts

- Do not work underneath the drink dispensers.
- Touching coffee, milk and hot water products may lead to scalding.
- Do not touch any of the dispensers before or after a product is being dispensed
- Do not open the lever while a product is being dispensed or the machine is being cleaned.
- Empty the drip tray with caution. Water can get very hot.

Machine overview

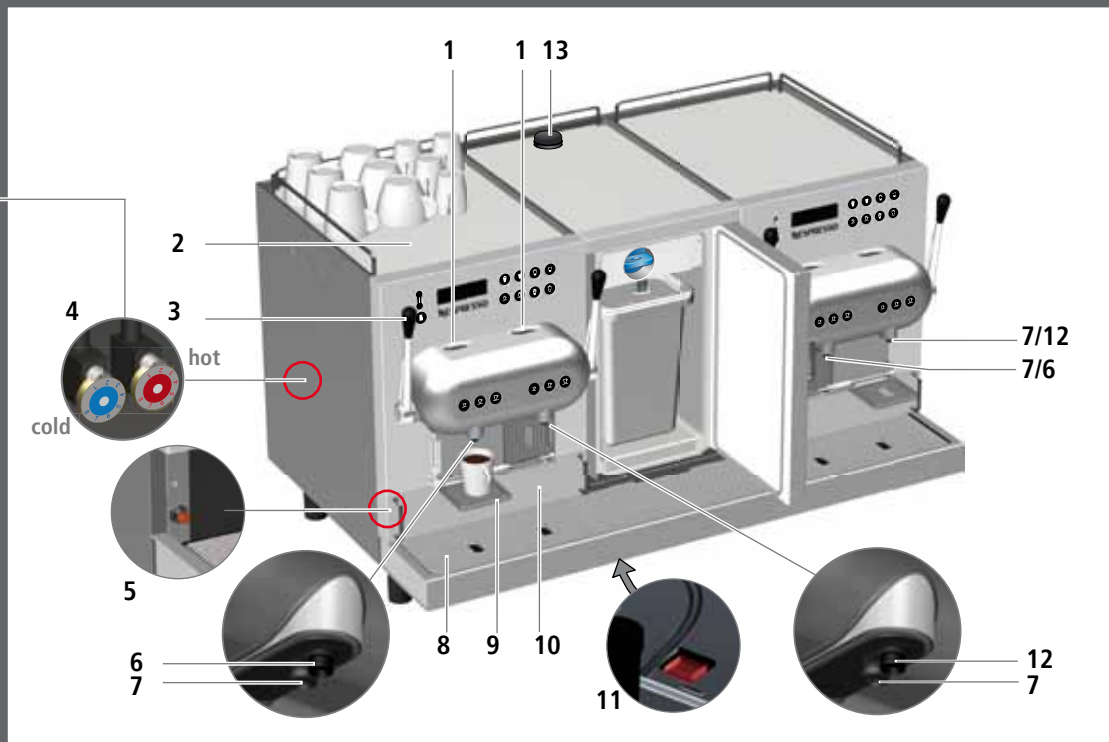
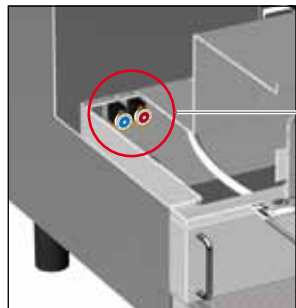

- 1 Capsule insertion slots
- 2 Cup heater
- 3 Lever
- 4 Milk froth regulator

- 5 Energy save button
- 6 Hot water outlet
- 7 Coffee outlet
- 8 Drip grid

- 9 Drip grid for small cups
- 10 Used capsule containers
- 11 Main switch (behind foot)
- 12 Hot water outlet

13 M2M technology antenna for added value services. Please see also page 28.

Refrigerator overview



- 1 Cleaning key
- 2 Milk suction tube
- 3 Milk container cover
- 4 Milk container
max. 5l



Always fill with cold milk
(below 5° C)

Operating overview



Hot water



Ristretto



Espresso



Lungo



Beverage selection

To view the name of the product on the display please press button for 5 sec. To exit wait 10 sec. without pressing any button.

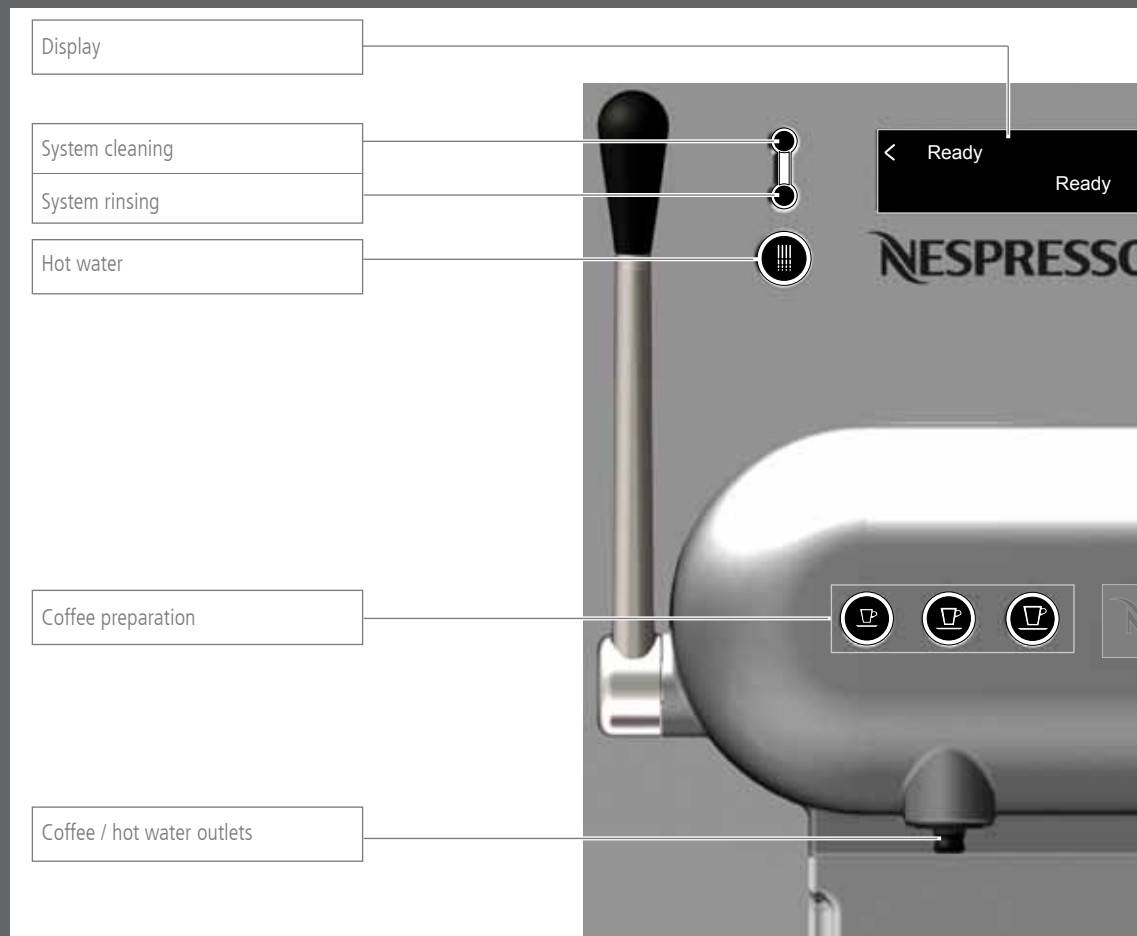

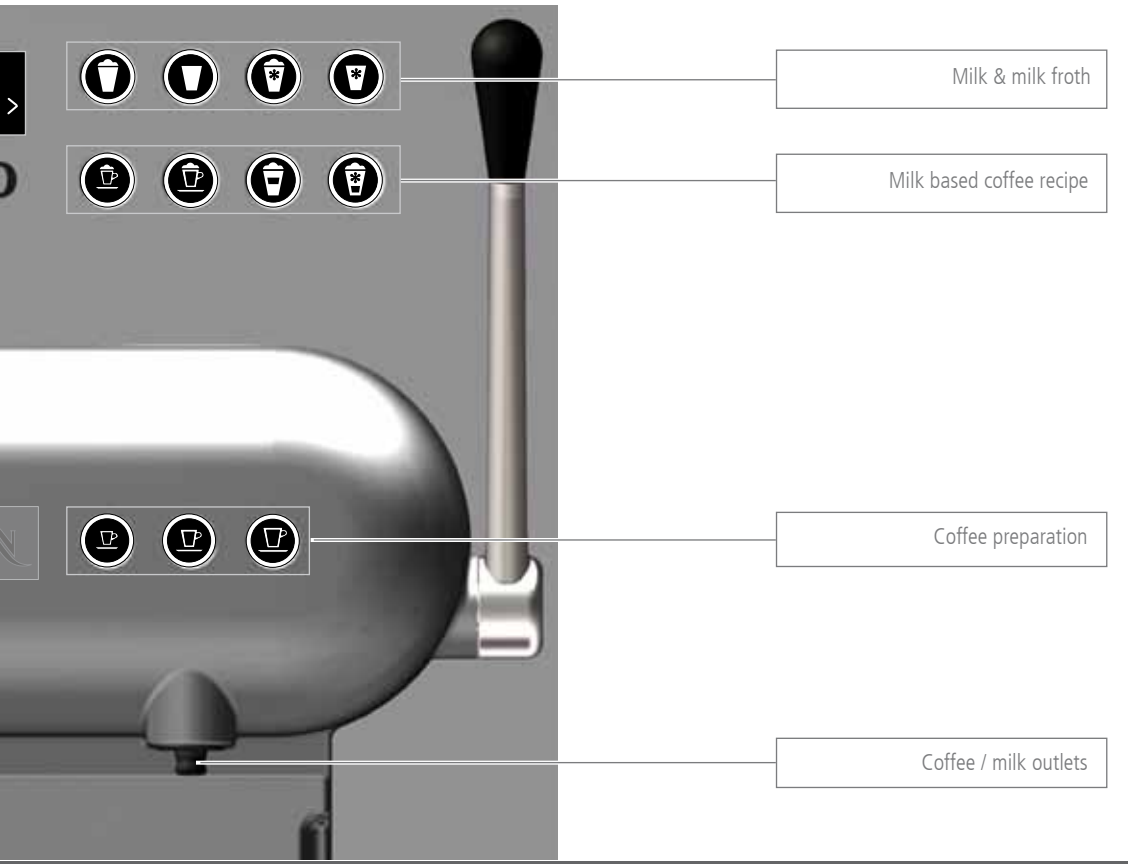











Milk & milk froth



















































Milk based coffee recipe

Coffee preparation

Coffee / milk outlets

-  Hot milk froth
-  Hot milk
-  Cold milk froth
-  Cold milk
-  Espresso Macchiato
-  Cappuccino
-  Latte Macchiato
-  Lattino
-  Ristretto
-  Espresso
-  Lungo

Nespresso Grand Cru
recommendation

	Ristretto Origin India	Ristretto	Espresso Forte	Espresso Leggero	Lungo Forte	Lungo Leggero	Espresso Decaffeinato	Lungo Decaffeinato		
Ristretto										  
Espresso										  
Lungo										  
Espresso Macchiato										   
Cappuccino										   
Latte Macchiato										   
Lattino										   

First use

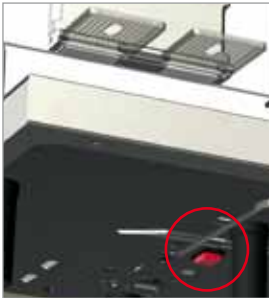

The main switch is located underneath the machine.

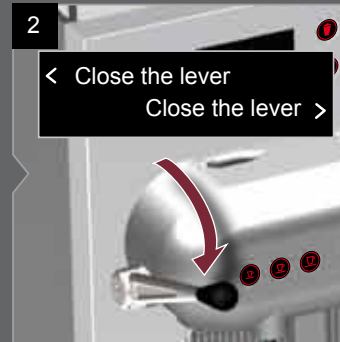

Close all four levers.



Don't put the fingers into the capsule insertion slots while closing the levers.

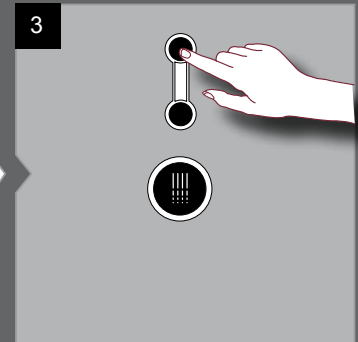

Press any button.

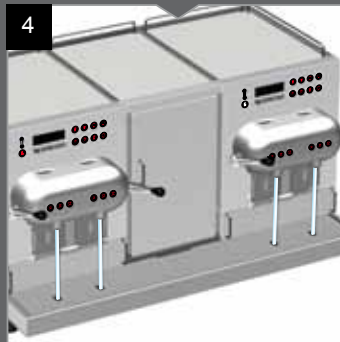

Machine performs a cold start rinse.

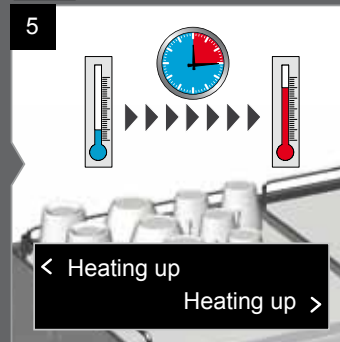

Machine heats up. All buttons blink in white.

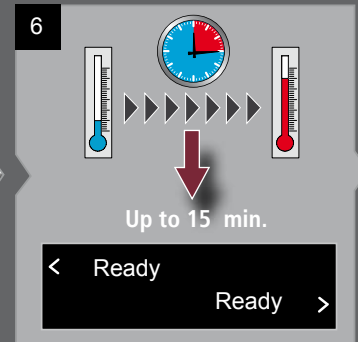

After the heating up time, all buttons shine in white.



Open house-installed water supply.



During rinsing the noise level increases.

First use



Open all four levers.



Thoroughly clean the milk container and cover with a merchantable household cleaner.

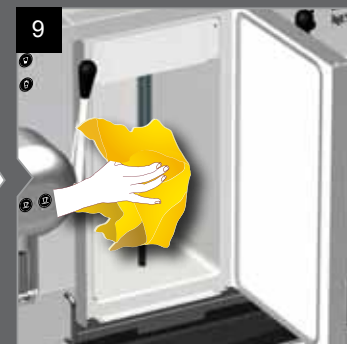

Wipe milk suction tube.

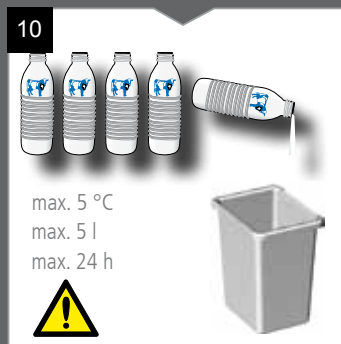

max. 5 °C
max. 5 l
max. 24 h

i Change the milk every 24 h.
Optional use the tetrapack
without milk container.



Insert milk suction tube
through cover into the milk
container.



Do not use unpasteurised milk!
Only use heat treated (e.g. pas-
teurised or ultra heat treated)
milk.

When pouring milk into the
container, pay attention to hygiene
to ensure that no contaminated
milk enters the system.

Energy save mode

- i** The machine switches to the energy save mode after 30 min. of non-use. All buttons appear in a dimmed white. Press any button to return to the operating mode of the machine.

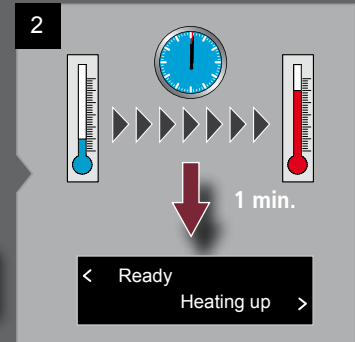
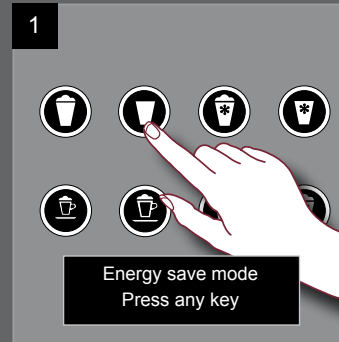

Maximum energy save mode

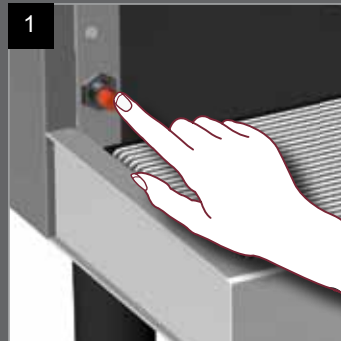

After two hours of non-use, the machine switches to the maximum energy save mode. Press the energy save button to restart.

- i** "Maximum energy save mode" can be activated by pressing the button for 3 sec.

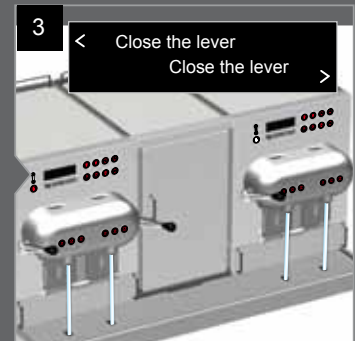
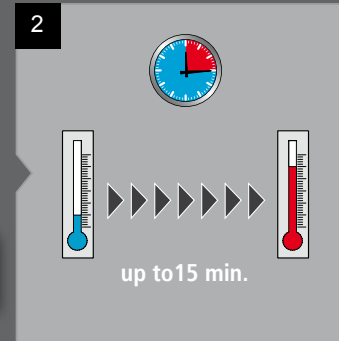

- i** Machine may require a cold start rinse. See first use on page 11. If required close all levers.

Coffee preparation

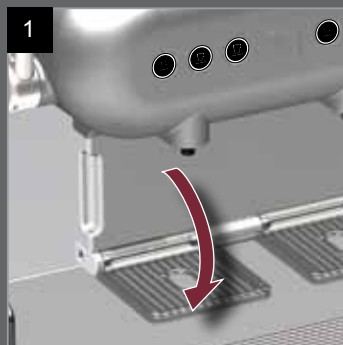

Pull down the drip grid for small cups.

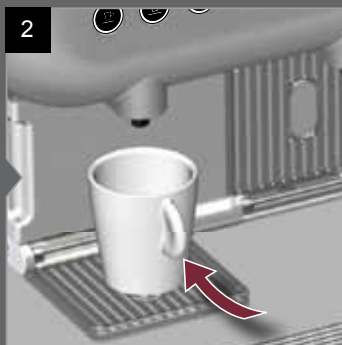

Choose preferred *Nespresso Grand Cru*.



Pull down the lever to the lowest position.

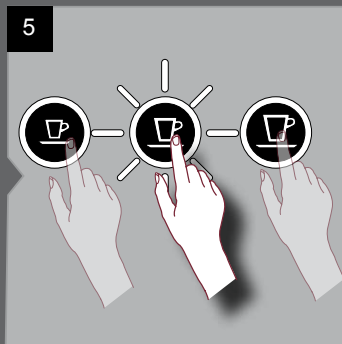

Choose cup size.

 See *Nespresso Grand Cru* recommendation on page 10.

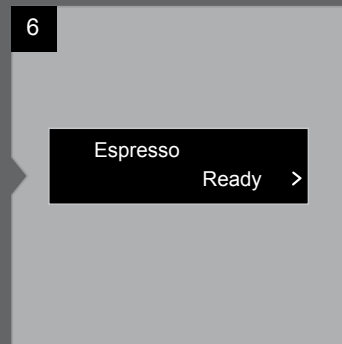

Product name is displayed during preparation.



For all coffee, milk and tea products:

Product preparation can be stopped by pressing the product button again.

To top up some coffee to your drink press the product button within 1 min. after the end of product preparation. Press button again to stop.

Coffee preparation

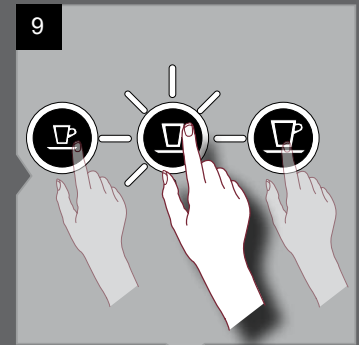
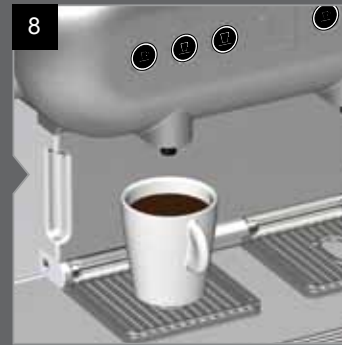
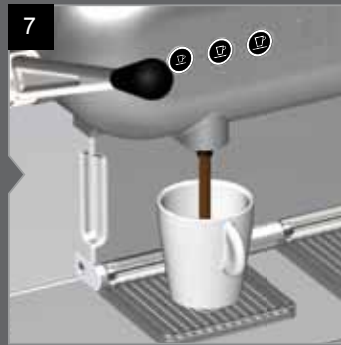

To top up see Info on page 14.



By pulling up the lever, the used capsule is ejected.



Machine is ready for next beverage.

Milk based coffee recipes

-  Espresso Macchiato
-  Cappuccino
-  Latte Macchiato
-  Lattino

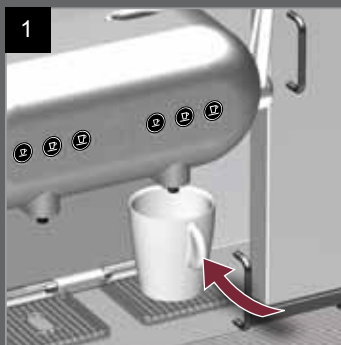

Choose preferred *Nespresso Grand Cru*.

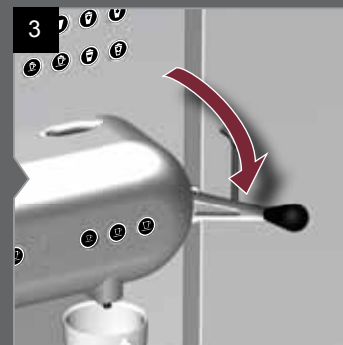

Pull down the lever to the lowest position.

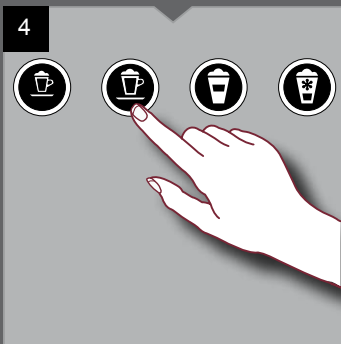

Choose coffee recipe desired.

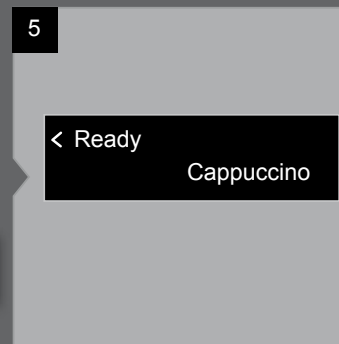

Coffee preparation.

Milk based coffee recipes



7
Frothing milk preparation according to chosen product.



8
By pulling up the lever, the used capsule is ejected.



10
A 10 sec. automatic rinsing of the internal milk system will begin 5 min. after the last milk based preparation is finished.

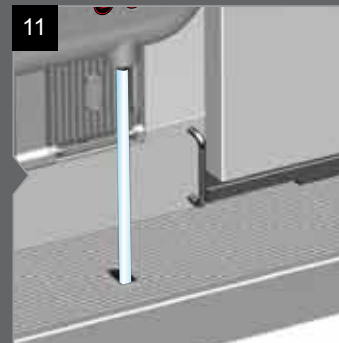

11
A 10 sec. automatic rinsing of the internal milk system will begin 5 min. after the last milk based preparation is finished.



Caution!
Risk of scalding!

Milk preparation



Hot milk froth



Hot milk



Cold milk froth



Cold milk

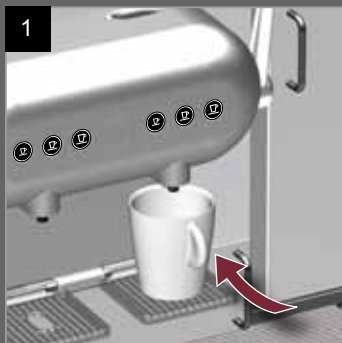

1

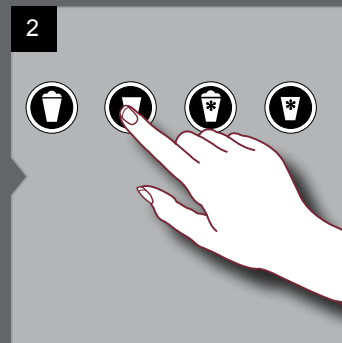

2

Choose milk product.

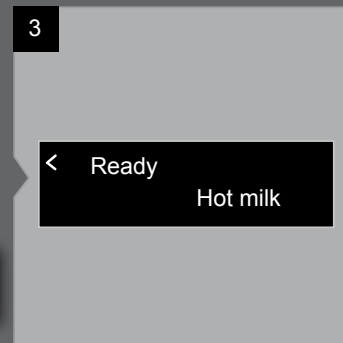

3



4

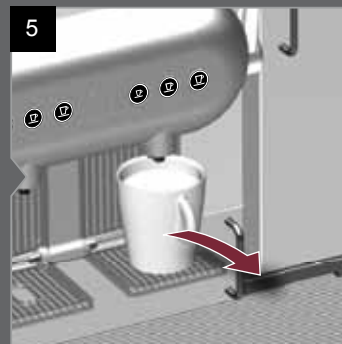

5

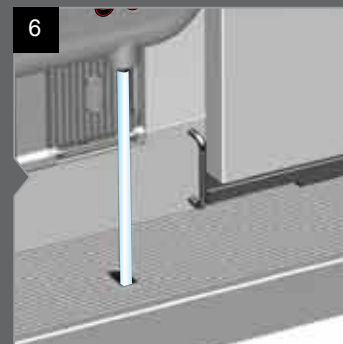

6

A 10 sec. automatic rinsing of the the internal milk system will begin 5 min. after the last milk based preparation is finished.



Caution!
Risk of scalding!

Hot water preparation



Hot water

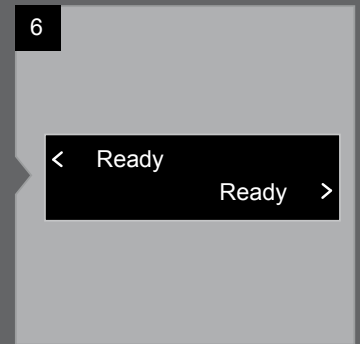
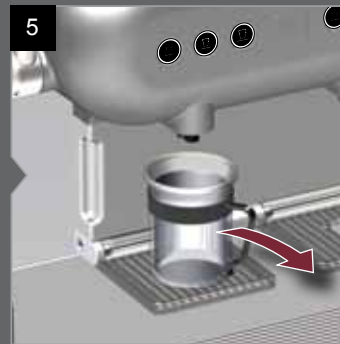
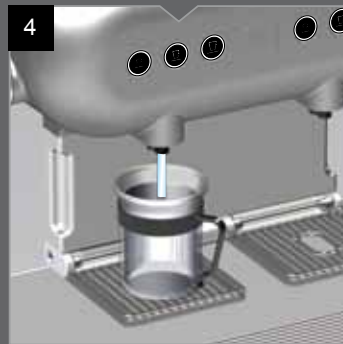
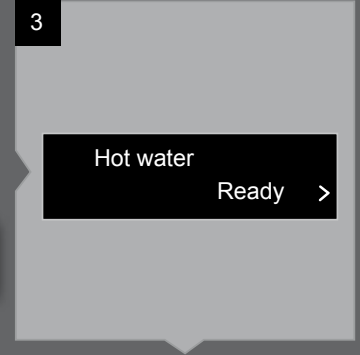
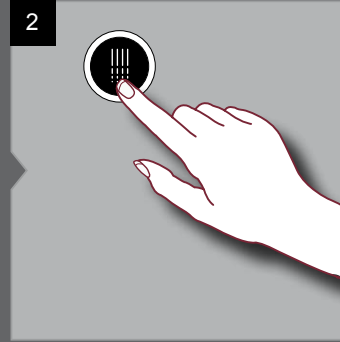
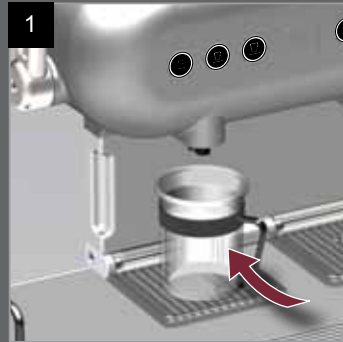

Caution!
Risk of scalding!



For more water, press the button again. Press again to stop.

Daily cleaning

Cleaning the machine on a daily basis is not only an absolute must, but it also guarantees the necessary hygiene and neutral taste as well as a longer life of the machine.

External cleaning

Remember to regularly inspect and, if necessary, clean the exterior of the machine.

Use a damp cloth or sponge soaked in a soap solution. Clothes and sponges must be wrung out thoroughly to ensure that they are only moist, not wet, otherwise there is a risk of electric shock.

Only use mild detergents and non-scratch cloths.

Pay particular attention to the product dispensing parts. The display and keyboard must be cleaned with particular care.

Internal cleaning

Follow these instructions carefully to run the automatic cleaning process.

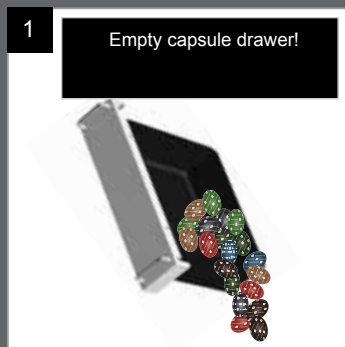

i Empty both capsule containers daily or on display request. (approx. 130 capsules per container)

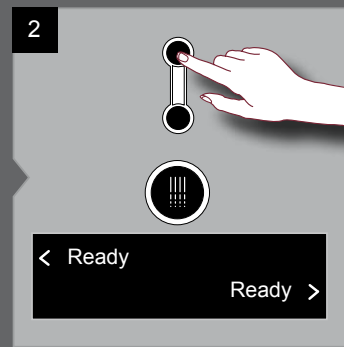

Press cleaning button.
i To exit mode press any button.

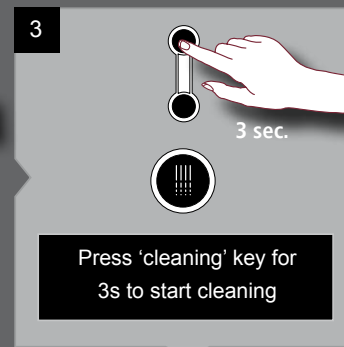

Press and hold the cleaning button again.



Press any key.

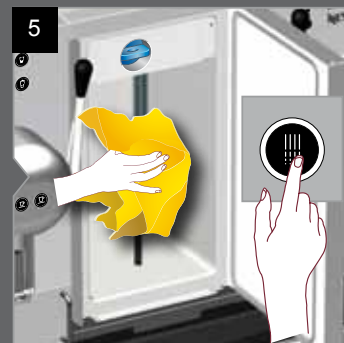

Wipe milk suction tube. Afterwards press any button.

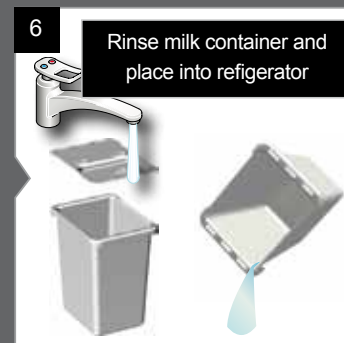

Rinse milk container with fresh water. Press any key.

Daily cleaning



After handling the cleaning tablets wash your hands!

Use only the Thermoplan milk cleaning tablets to perform the automatic cleaning process.

Do not use any other cleaning detergent or disinfection agent for this purpose.

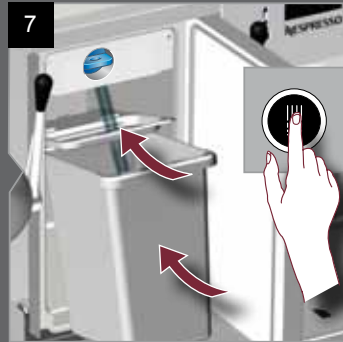

i Container must be empty. Afterwards press any button.



i Remove cleaning key and insert two cleaning tablets.



i When key inserted cleaning starts automatically.

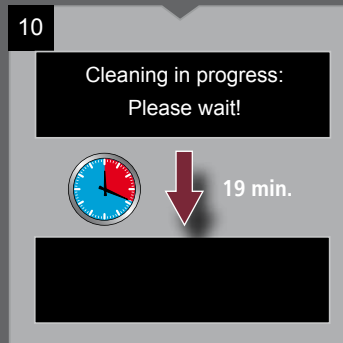

After cleaning process the machine switches to the maximum energy save mode.

i Cleaning process lasts approx. 19 min. during which all buttons shine red.

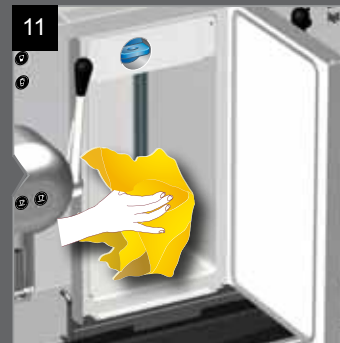

i After cleaning, empty remaining water and thoroughly clean suction tube and milk container with potable water



Daily cleaning

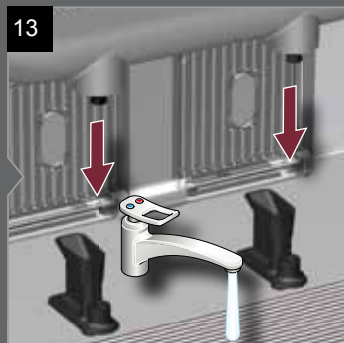

13 Pull down coffee outlets and clean them.



Caution!
Risk of scalding!

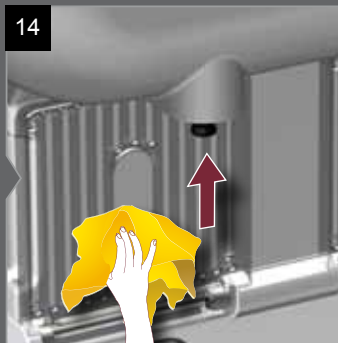

14 Clean the milk outlets with a cloth.



Caution!
Risk of scalding!

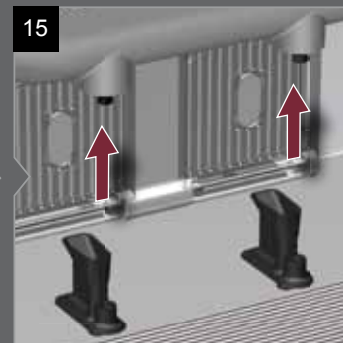

15 Insert coffee outlets.

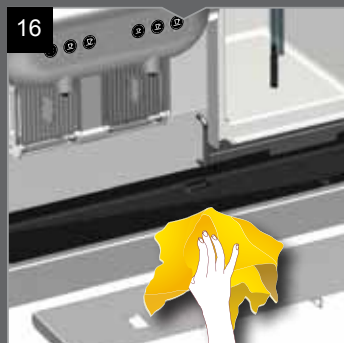

16 Clean entire outside of machine.

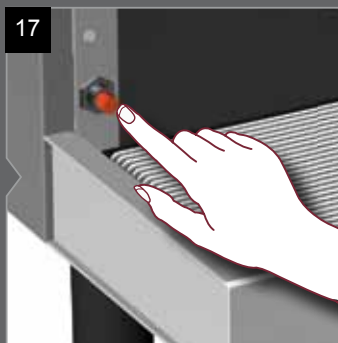

17 After cleaning process the machine switches to the energy save mode. To restart the machine, press the energy save button.

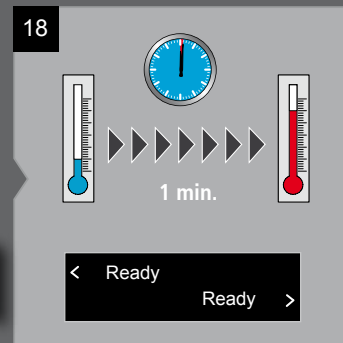

18 It may require up to 15 min. to return to ready mode. See also page 13.

Milk froth settings

- 1 Unpasteurised milk
- 2 Pasteurised milk
- 3 Ultra heat treated milk (UHT)



Do not use unpasteurised milk! Only use heat treated (e.g. pasteurised or ultra heat treated) milk.

When pouring milk into the container, pay attention to hygiene to ensure that no contaminated milk enters the system.



The ideal temperature for frothing milk is 5°C (if the temperature is above 8°C, the froth quality will be reduced significantly).

The milk variety has an influence on froth quality. When switching from pasteurised to UHT milk, it may be necessary to adjust the milk froth settings.

Most suitable quality for frothing milk is UHT milk. Pasteurised milk is a little more difficult to froth.

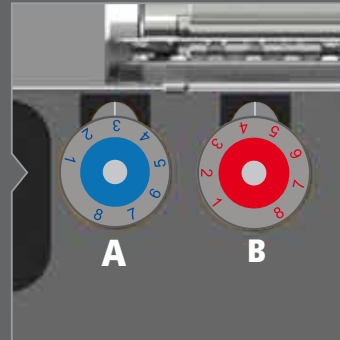
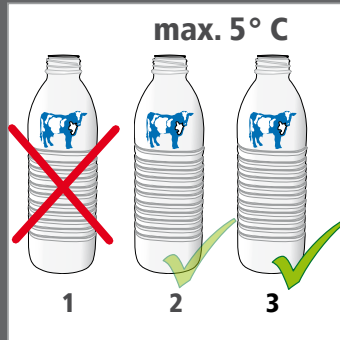

A Cold milk froth regulator.

B Hot milk froth regulator.

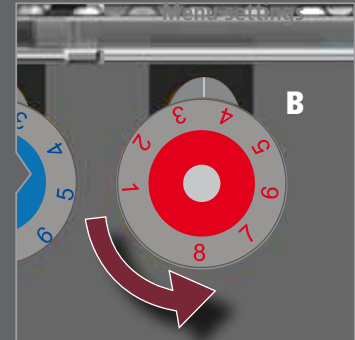

Turn right setting control (B) until air bubbles are visible. Then turn setting control back slightly.



System responds slowly.

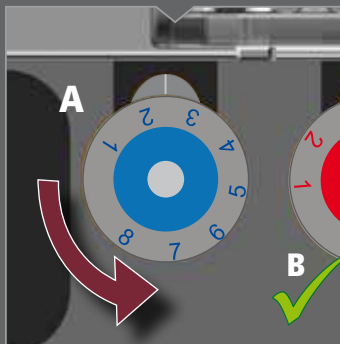

Repeat procedure with left setting control for cold milk froth (A).



Do not change right setting control (B).
System responds slowly.

Factory setting

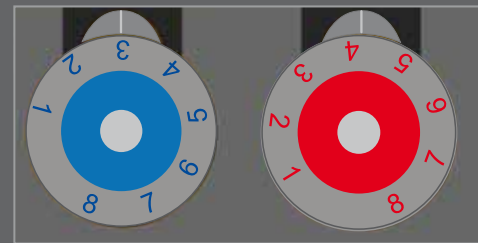

around 2-3

3-4

Menu settings

Language setting

Press and hold the rinse button for 3 sec. 

USER MENU
GENERAL SETTINGS



Select menu "Language"

Enter   

GENERAL SETTINGS
Language English

Select "Language"

Enter  

Exit menu   

Statistic

Press and hold the rinse button for 3 sec. 

USER MENU
< GENERAL SETTINGS >

Select menu "statistic"

Enter  

STATISTICS
User product counter

Select "user product counter"

Enter  

User product counter
< select a product >

Espresso
← 4 2 →



On the second display, the statistic of all four outlets is shown.





User counter reset

User counter reset
< yes / no >

Select yes or no



Enter   

Exit menu   

- | | | | |
|--|---------|--|---|
|  | Up | Next menu / Increase value (Clean button) | 1 |
|  | Down | Previous Menu / Values decrease (Rinse button) | 2 |
|  | Default | Load Default value / (Ristretto button) | 3 |
|  | Enter | Edit / Confirm (Espresso button) | 4 |
|  | Escape | Exit menu / Cancel (Lungo button) | 5 |

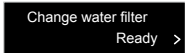
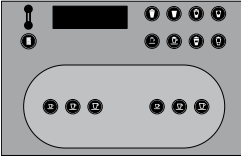
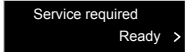
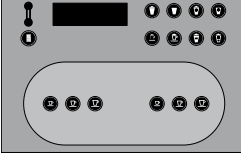

Alarms

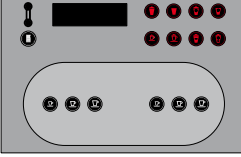
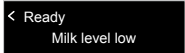
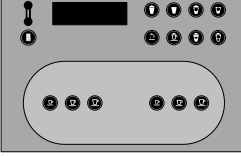
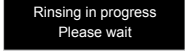
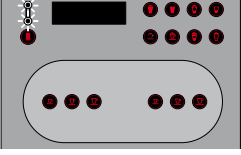



Description	Display message	LED status	Remarks
Change water filter	 <p>Change water filter Ready ></p> <p>Alternating</p>		Immediately call <i>Nespresso</i> representative.
Service required	 <p>Service required Ready ></p> <p>Alternating</p>		Immediately call <i>Nespresso</i> representative.
Milk tank empty	 <p>< Ready Add Milk</p> <p>Alternating</p>		Milk products are locked. Fill up the milk container (in fridge).
Milk level low	 <p>< Ready Milk level low</p> <p>Alternating</p>		Preliminary information that milk soon will be finished. Fill up milk container.
Automatic rinsing mode (5 min. delay)	 <p>Rinsing in progress Please wait</p>		Automatic rinsing of internal milk system starts 5 min. after last milk based preparation. The messages "Rinsing in progress" and "Please wait" appear on the display and the LED starts to blink 10 sec. before rinsing begins.

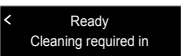
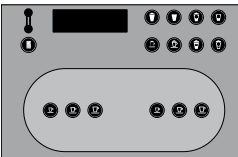

What to do if a "Call technician" message appears?

Please call your *Nespresso* representative.

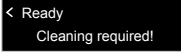
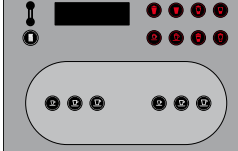
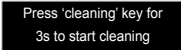
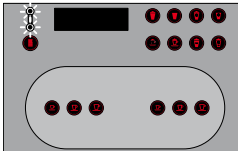
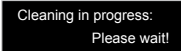
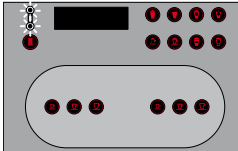
Alarms

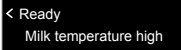
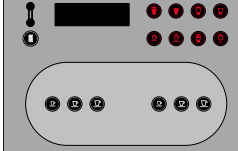
Description	Display message	LED status	Remarks
Cleaning required in xy min.	 <p>Ready Cleaning required in Alternating</p>		<p>When timer ends machine will be locked until cleaned.</p> <p> Only milk products will be blocked. Timer starts 2h before locking milk preparation.</p>
Milk products not available	 <p>Ready Cleaning required! Alternating</p>		<p>Milk products not available. Start cleaning as described on page 20.</p>
Cleaning of milk system	 <p>Press 'cleaning' key for 3s to start cleaning</p>		<p>To start cleaning see page 20. To exit menu press any product button.</p>
Milk system cleaning mode	 <p>Cleaning in progress. Please wait!</p>		<p>Display shows remaining cleaning time.</p> <p> If the machine is switched off during cleaning, the machine will request to clean again when switched on!</p>
Milk temperature high	 <p>Ready Milk temperature high Alternating</p>		<p>Milk products are locked. Replace milk with cold milk (below 8° C)</p>

Alarms

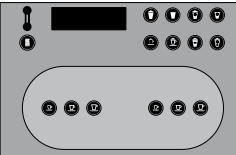
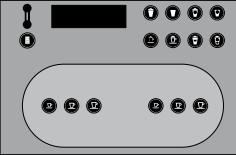
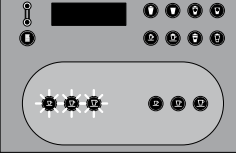
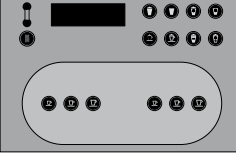
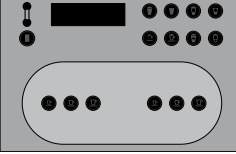
Description	Display message	LED status	Remarks
Preparation time too long	<div data-bbox="657 191 839 241" style="background-color: black; color: white; padding: 2px;"> Preparation too long < Lift the lever </div> <p style="text-align: center;">Alternating</p>		Open lever and try new capsule. If message repeatedly appears, check the facility supplied water connection.
Preparation time too short	<div data-bbox="657 368 839 418" style="background-color: black; color: white; padding: 2px;"> Preparation too short < Lift the lever </div> <p style="text-align: center;">Alternating</p>		Open lever and try new capsule. Message appears if no capsule is inserted. If messages appears repetitive call <i>Nespresso</i> representative.
Heating up boiler 1	<div data-bbox="657 540 839 591" style="background-color: black; color: white; padding: 2px;"> < Heating up Ready > </div> <p style="text-align: center;">Alternating</p>		Slow blinking during heating - Call <i>Nespresso</i> representative if message remains for more than 30 min.
Energy save mode	<div data-bbox="657 713 839 763" style="background-color: black; color: white; padding: 2px;"> < Energy Saving mode: Press any key > </div>		Boiler temperature reduced. Machine will be ready within 1 min. after pressing any product button.
Maximum energy save mode	<div data-bbox="657 880 839 930" style="background-color: black; color: white; padding: 2px;"> < Energy Saving mode: Press any key > </div>		<p>Reactivation: To reactivate machine press Energy Save button. For more info see page 15.</p>

Specifications

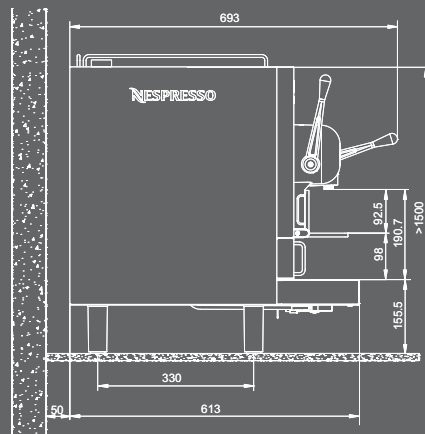
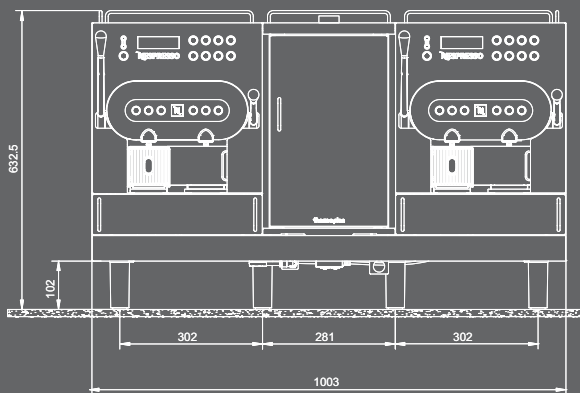

Power supply: 220-240 V / 50/60 Hz / 2850-3150 W
380-415 V / 50/60 Hz / 8600-9400 W
208 V / 60 Hz / 8300 W

Dimension: 1003 x 693 x 632 mm (L /D /H)

Weight: 100 kg (empty)
120 kg (in operation)

Outlet height standard: 190 mm

Outlet height drip grid: 90 mm

Water supply: G 3/8" male

Water supply pressure: 2-4 bar / 30-60 psi

Noise emission: <70 dB



Product capacity/h depending on the power supply

Espressos	240
Ristrettos	240
Lungos	200
Milk based beverages	150
Hot water	160

Chlorine:	none
TDS:	70 to 200 ppm
Total hardness:	5-8 °dH (8-14 °fH)

Alkalinity:	pH 6.8 to 7.4
Iron:	less than 100 ppm



This coffee machine is equipped with M2M (Machine to Machine) technology which may be activated along with your agreement. Thanks to a SIM card that is already integrated in the machine, such network connections will offer new services (subject to further terms and conditions) to its customers and improve the after sales process by automatically communicating machine troubleshooting / diagnostics to our Customer Relationship Centre (depending on country requirements and specificities).



The capsule container must be removed to see the type plate.

The type plate is located beneath the left capsule container on the baseplate.

The type plate contains the following details:

Machine type:	Automatic Coffee Machine
Model:	AGUILA
Type:	AG420PRO
Voltage:	according to type plate
Power:	according to type plate
Net water:	0.2-0.4 MPa (2-4 bar)
Hydr. boiler:	1.46 MPa (14.6 bar)
Class:	5 (T)
Refrigerant:	134a
Charge:	55 g
Serial number:	according to type plate
Production date:	according to type plate

Manufacturer

Thermoplan AG
Roehrlistrasse 22
CH - 6353 Weggis

Original user manual

EU DECLARATION OF CONFORMITY

We **Thermoplan AG, Roehrlistrasse 22,
CH-6353 Weggis, Switzerland**

declare under our sole responsibility that the
product

Product Automatic Coffee Machine
Model AGUILA
Type AG420PRO

to which this declaration relates is in conformity
with the following standards and corresponding
IEC standards:

EN 50366:2006

EN 55014-1:2009

EN 55014-2:2008

EN 60335-1:2010

EN 60335-2-15:2008

EN 60335-2-75:2010

EN 60335-2-89:2010

EN 61000-3-11:2000

EN 61000-3-12:2005

EN 61000-3-2:2009

EN 61000-3-3:2008

EN 61000-6-1:2007

EN 61000-6-3:2011

EN 62233:2008

ETSI EN 301 489-1:2008 (V1.8.1)

ETSI EN 301 489-7:2005 (V1.3.1)

EN 301511 (V9.0.2)

following the provisions of Directives

2011/65/EU (RoHS)

1999/5/EC (RTTED)

2004/108/EC (EMC)

2006/42/EC (MD)

This product also complies with essential safety
requirements of the Low Voltage Directive

2006/95/EC

CH-6353 Weggis, 19.09.2011

Adrian Steiner, CEO



Responsible for the technical documentation is:

Andreas Zimmermann

