

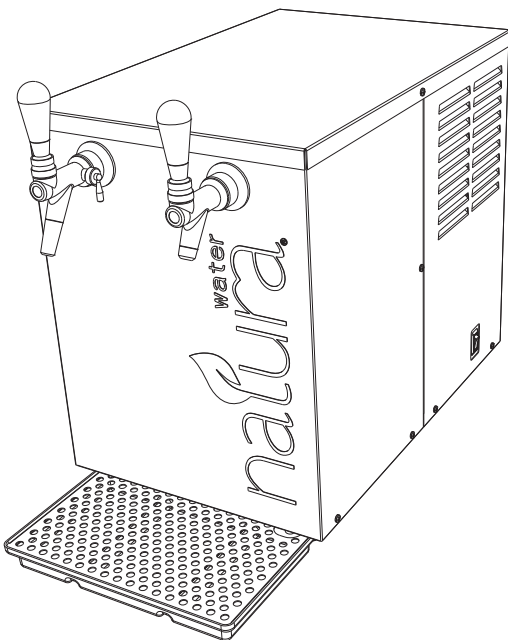

INSTALLATION AND MAINTENANCE GUIDE FOR:

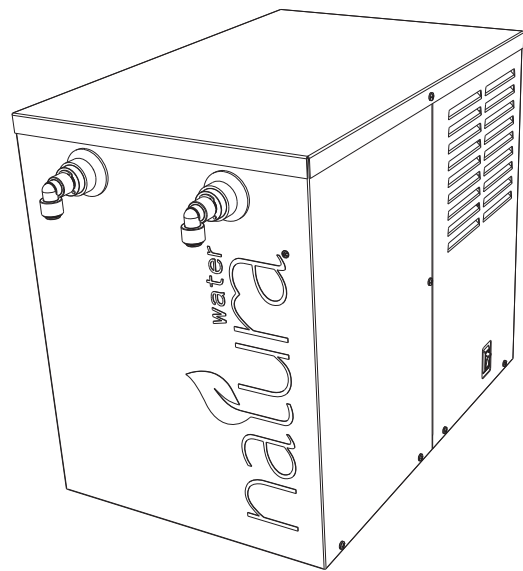

NATURA
MODEL NWSB SER.4
COUNTERTOP WATER DISPENSER
(Aquarius Series)



NATURA
MODEL NWSBU2 SER.4
REMOTE CHILLER
(Aquarius Series)

NATURA Water LLC.
222 East Campus View Blvd
Columbus, Ohio 43235
U.S.A.

1. PRODUCT SPECIFICATIONS
2. IMPORTANT REQUIREMENTS
3. SAFETY WARNINGS
4. DIRECTIONS FOR PROPER PLACEMENT OF THE COMPONENTS
5. PROPER QUICK CONNECT FITTING CONNECTION INSTRUCTIONS
6. COUNTER TOP MODEL SCHEMATIC
7. WATER INLET/FILTRATION INSTALLATION
8. WATER INLET/FILTRATION INSTALLATION: STEP 1
9. WATER INLET/FILTRATION INSTALLATION / FILTER INSTALLATION: STEP 2
10. WATER INLET/FILTRATION INSTALLATION: STEP 3
11. WATER INLET/FILTRATION INSTALLATION: STEP 4
12. CO₂ SUPPLY SYSTEM INSTALLATION
13. COUNTER TOP MODEL INSTALLATION
14. COUNTER TOP MODEL TAP INSTALLATION
15. REMOTE CHILLER MODEL SHANK ASSEMBLY
16. REMOTE CHILLER MODEL INSTALLATION
17. FLOW COMPENSATOR ADJUSTMENT
18. WATER LEAK PROTECTION DEVICE ADJUSTMENT
19. START UP PROCEDURE
20. DRIP TRAY PLACEMENT
21. FILTER REPLACEMENT
22. MAINTENANCE
23. SPARE PARTS DRAWING - MODEL NWSB SER.4
24. SPARE PARTS DRAWING - MODEL NWSBU2 SER.4
25. TROUBLESHOOTING
26. CONTACT INFORMATION

1. PRODUCT SPECIFICATIONS:

Dimensions:

Length	19.0"
Length with Drip Tray	24.5"
Width	12.5"
Height	17.9"
Height with Taps	19.9"
Weight - Empty	65 lbs
Weight - with Water	100 lbs

Refrigerant: 3.2 ounces, R-134a

Input Voltage: 115 VAC, 60 HZ, SINGLE PHASE

Amperage: 2.6 AMPS FLA

Minimum Ambient Temperature: 40° F (4.5° C)

Maximum Ambient Temperature: 104° F (40° C)

Inlet Water Pressure: 45 PSI to 120 PSI - If your inlet water pressure does not meet this minimum pressure requirement you may need an expansion tank.

CO₂ Pressure Input: Target 60 PSI, Maximum 65 PSI (food grade CO₂ only)

IMPORTANT:

Dedicated CO₂ Tank

For dedicated CO₂ Tank systems, use the supplied CO₂ Pressure Regulator.

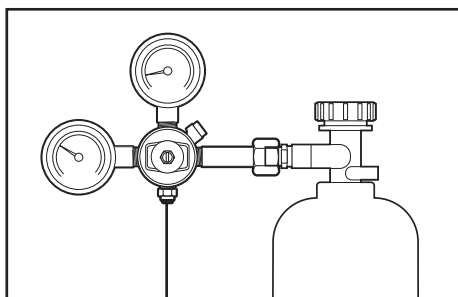

Existing CO₂ System (Bulk)

For bulk CO₂ systems, use a dedicated CO₂ Pressure Regulator set at 60 PSI.

2. IMPORTANT REQUIREMENTS:

- o Use only original and new parts to guarantee the reliability, optimization, and performance of the Natura water machine.
- o Always wear proper protection when performing any type of service or maintenance.
- o Do not expose the CO₂ Cylinder to direct sun light, to sources of heat, or to temperature below 32° F (0° C).
- o Always keep the CO₂ Cylinder in a vertical position while in use and secure properly with a chain or strap.
- o To properly carbonate the water, make sure that CO₂ Cylinder valve is completely open.
- o Use only food grade CO₂ (UN1013) gas.
- o Adjust the CO₂ Pressure Regulator to a target of 60 PSI with a 65 PSI maximum.
- o When cleaning the unit, do not use corrosive, acidic products, or metal brushes.
- o Do not wash the unit using high-pressure water.
- o Connect to a water supply with a pressure of 45 to 120 PSI.

3. SAFETY WARNINGS:

- o The unit must be connected to a 115 VAC, 15 amp GFCI power supply. Operating voltage is listed on the equipment data label.
- o The unit must be protected by a properly installed circuit breaker. Verify that the electrical current is correct for the power of the unit, which is listed on the machine data label.
- o To avoid electrical shock always unplug the unit from the electrical outlet before servicing.
- o All packaging materials (plastic bags, foam, etc.) should never be left within the reach of small children. These items are potentially hazardous and may cause severe injury or death.
- o CO₂ is a high pressure gas – use caution when moving or making connections.

4. DIRECTIONS FOR PROPER PLACEMENT OF THE COMPONENTS:

- o Place the unit in an appropriate location, far from heat sources and with adequate ventilation, on a flat level surface. The surface must be able to support the 100 lb weight of the unit.
- o Locate the unit within 10 feet of a water supply.
- o Locate the unit within 6 feet of a 115 VAC, 15 amp GFCI power supply.
- o Locate the Filter Set within 5 feet of the unit.
- o Maintain at least 6 inches of clearance on both sides and 2 inches in back for proper ventilation.



COUNTER TOP MODEL
MODEL

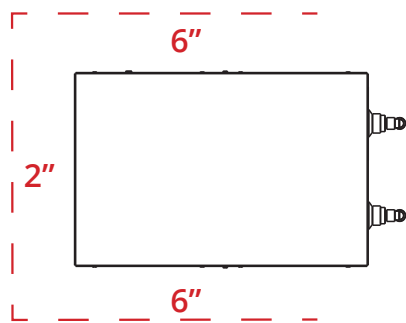

REMOTE CHILLER MODEL

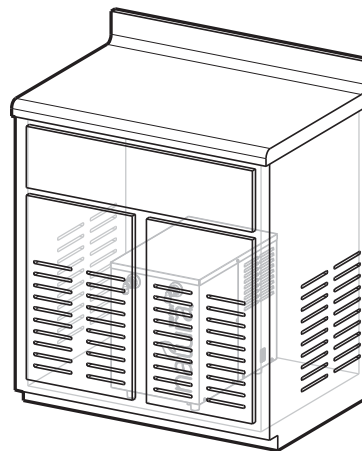

REMOTE CHILLER
MODEL

- o For Remote Chiller Model: provide ventilated cabinet doors and sides to allow for fresh air into the evaporator coil side and exhaust air out side. Without proper ventilation the unit will not perform properly and will shorten the life of the Compressor.
- o Allow 14 inches minimum above the unit for removing the Top to perform routine maintenance, **and to allow for checking of the water level in the Reservoir during routine maintenance.**
- o The Water Leak Protection Device must be connected directly to the Braided Inlet Water Line at the customer supplied valve.

5. PROPER QUICK CONNECT FITTING CONNECTION INSTRUCTIONS:

Connections between the Pressure Regulator, Filtration Unit and Water Refrigeration Unit are accomplished using plastic tubing and push-together quick-connect type fittings.

PLASTIC TUBING

1. Cut tube ends square and straight. Do not deform the tube (i.e., cause tube to compress its diameter so it is no longer round).
2. Make sure the outer surface of the tube is clear of marks or scratches for a length equal to the "O" ring thickness to seat properly against the tube.
3. Avoid sharp changes in direction when routing the tubing. Sharp turns cause the tubing to flex and deform which reduces its low capacity

QUICK-CONNECT FITTINGS

Fittings consist of two parts: a body and a colored collet.

1. To install a tube, push it through the collet until it seats firmly at the bottom of the fitting.
2. To remove tube, push and hold the collet against the body while pulling the tube out.

Note: Systems are shipped with a plug in each external fitting. Remove a plug in the same manner as a tube.

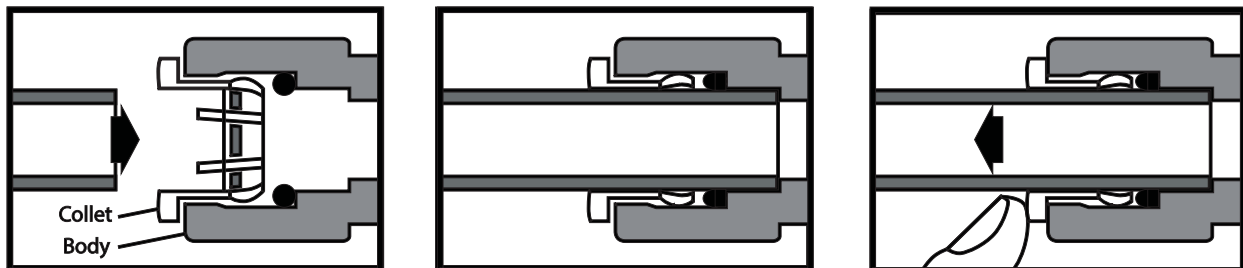

6. COUNTER TOP MODEL SCHEMATIC:

WATER INLET/FILTRATION SYSTEM

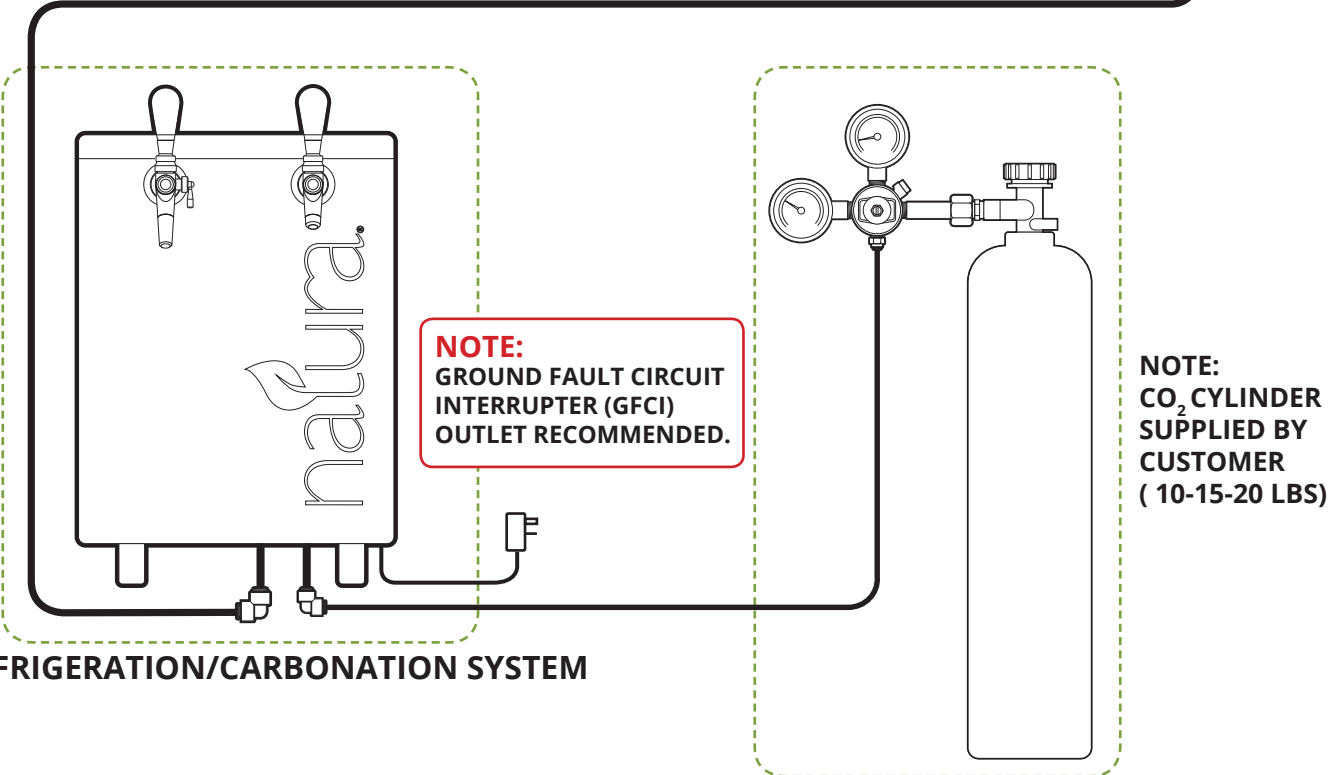
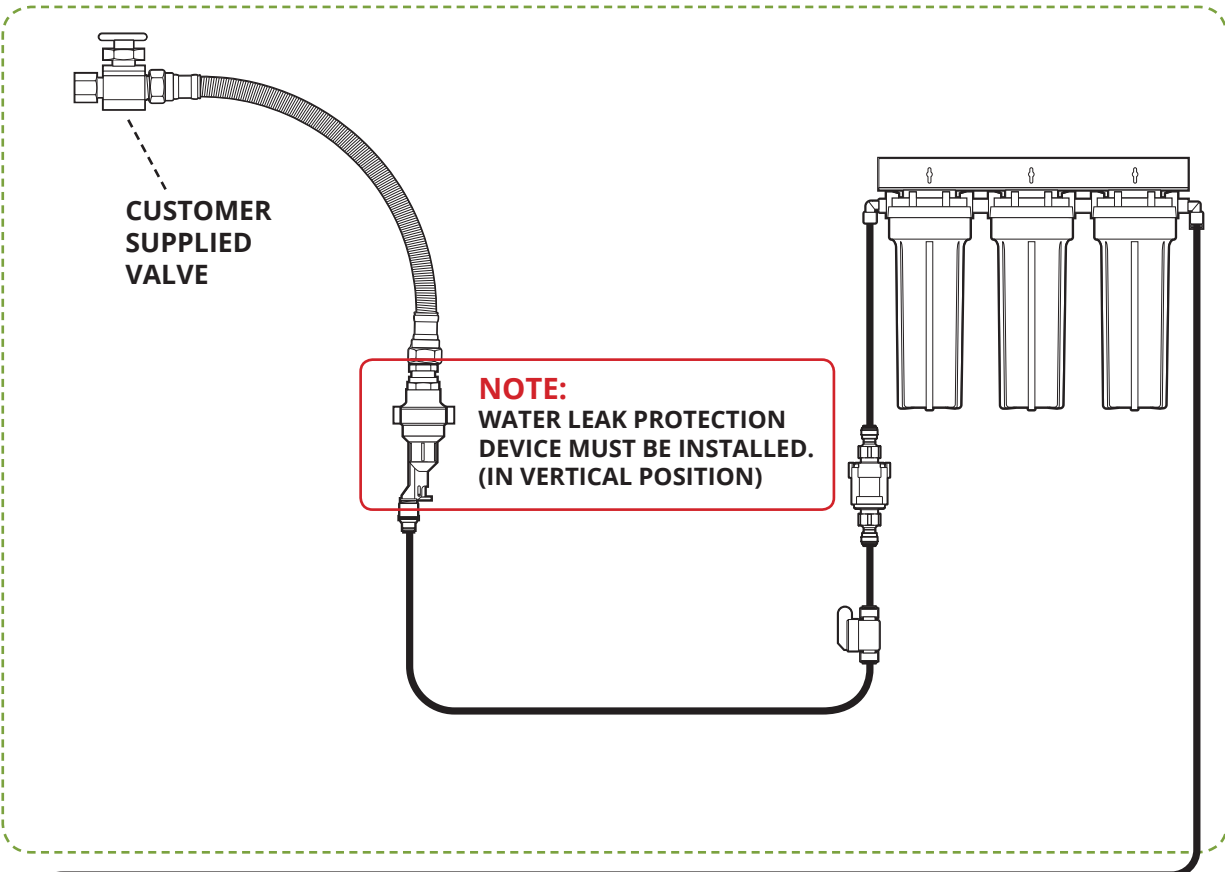

REFRIGERATION/CARBONATION SYSTEM

CO₂ SUPPLY SYSTEM

7. WATER INLET/FILTRATION INSTALLATION:

NOTE:

WATER LEAK PROTECTION DEVICE MUST BE INSTALLED PROPERLY IN VERTICAL POSITION PER INSTRUCTIONS PROVIDED.

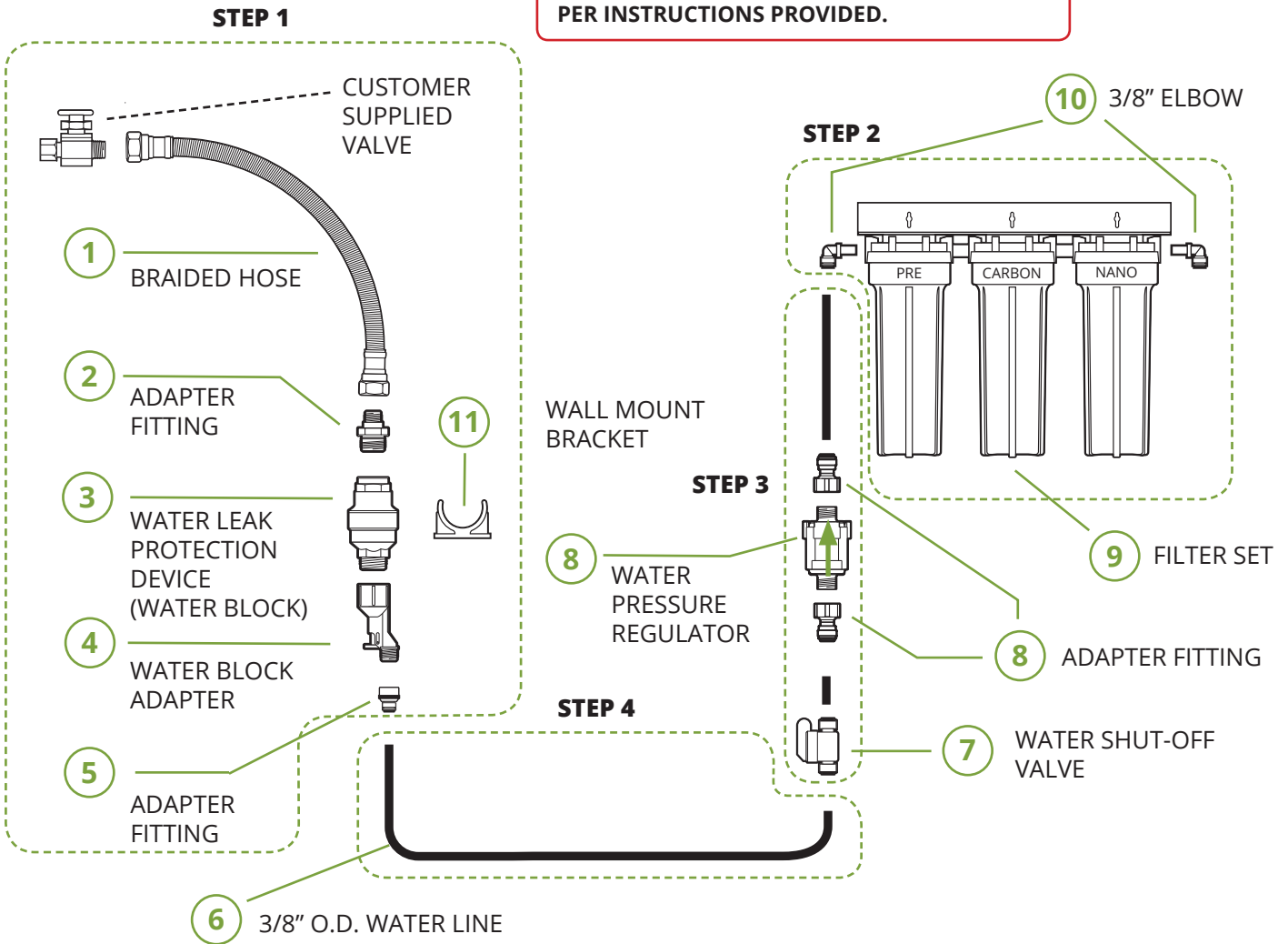

1. Connect the components in order as shown above. Additional assembly / adjustment will be required for the Water Leak Protection Device. This is detailed in Section 18.

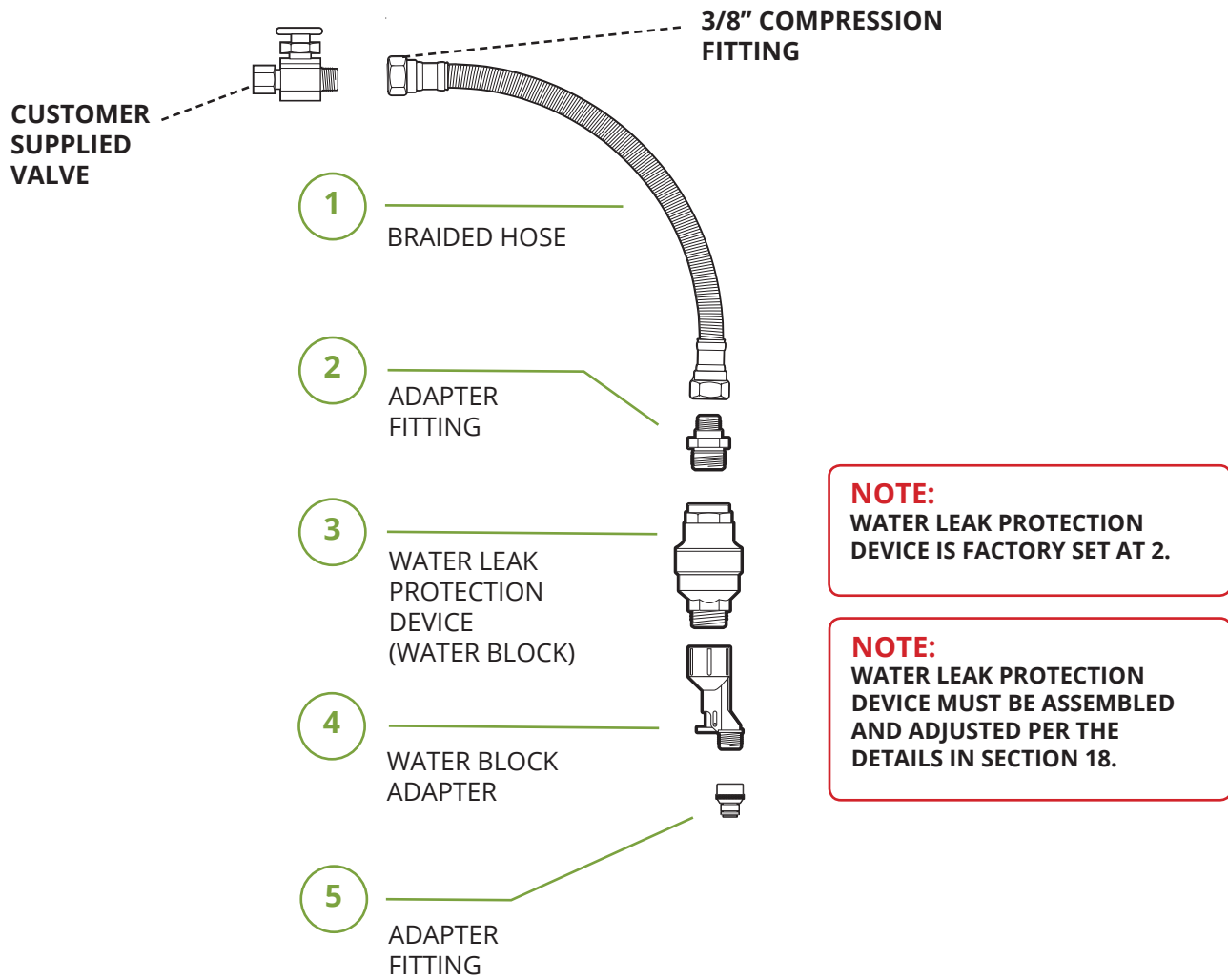

1. Connect the components in order as shown above. Additional assembly / adjustment will be required for the Water Leak Protection Device. This is detailed in Section 18.

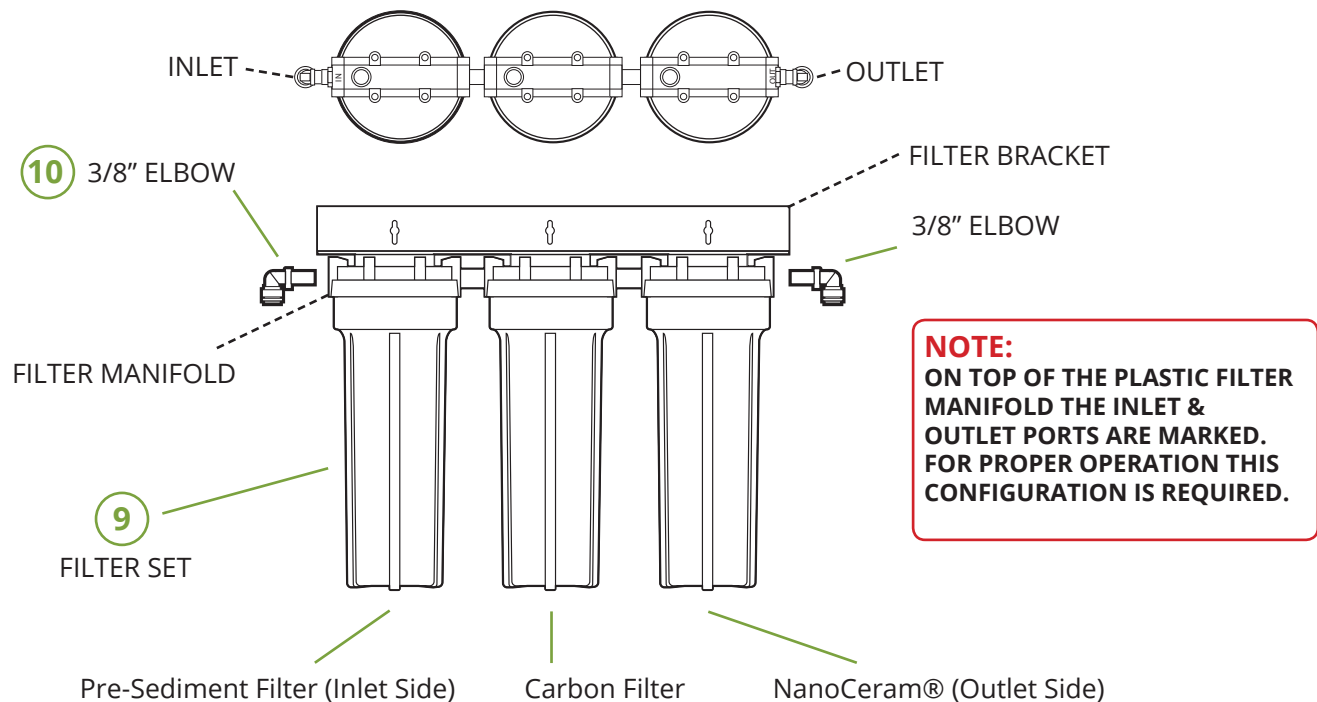

WARNING: DO NOT USE WITH WATER THAT IS NOT MICROBIOLOGICALLY SAFE OR OF UNKNOWN QUALITY.

ATTENTION: IT IS IMPORTANT TO MAKE PROPER CONNECTIONS TO THE QUICK CONNECT FITTINGS TO AVOID LEAKS. SEE PAGE 3.

CAUTION: DO NOT PLACE UNDUE STRESS OR SIDE LOAD ON ANY OF THE PLASTIC FITTINGS.

1. Place the Countertop Water Dispenser or Remote Chiller no more than 10 feet from the water source. Place the Filter Set exactly between the two.
2. Mark the Filter Set inlet and outlet on the Filter Bracket and Filter Housings before securing the Filter Bracket to the Filter Manifold.
3. Secure the Filter Bracket to the wall or other structure using the proper fasteners. The Filter Bracket can be turned over for space requirements. The mounting holes will be located behind the Filter Head in this configuration.
4. Assemble 3/8" Elbow Fittings to inlet and outlet ports on Filter Manifold.
5. Install the Filters into the Filter Housings. **NOTE: ENSURE THE PROTECTIVE PLASTIC WRAPPERS ARE REMOVED FROM THE FILTERS.** The Pre-Sediment Filter (white) is assembled on the left. The Carbon Filter (black with netting) is located in the center. The Nano Ceram Filter (pleated with netting) is located on the right. Ensure the cartridge slips over the stand pipe in the bottom of the housing. Hand tighten. **DO NOT OVER TIGHTEN.**

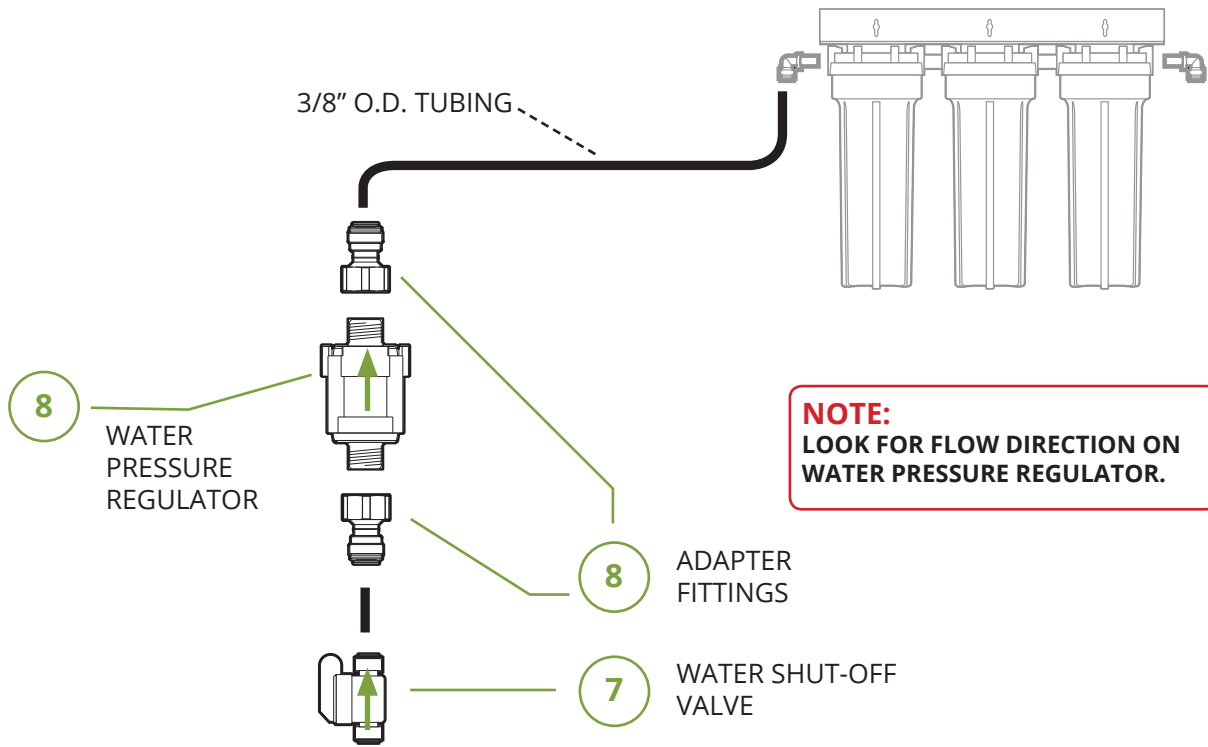

1. Connect the components in order as shown above.
2. Connect 3/8" O.D. tube from Water Pressure Regulator exit port to the 3/8" elbow inlet port on the Filter Set.

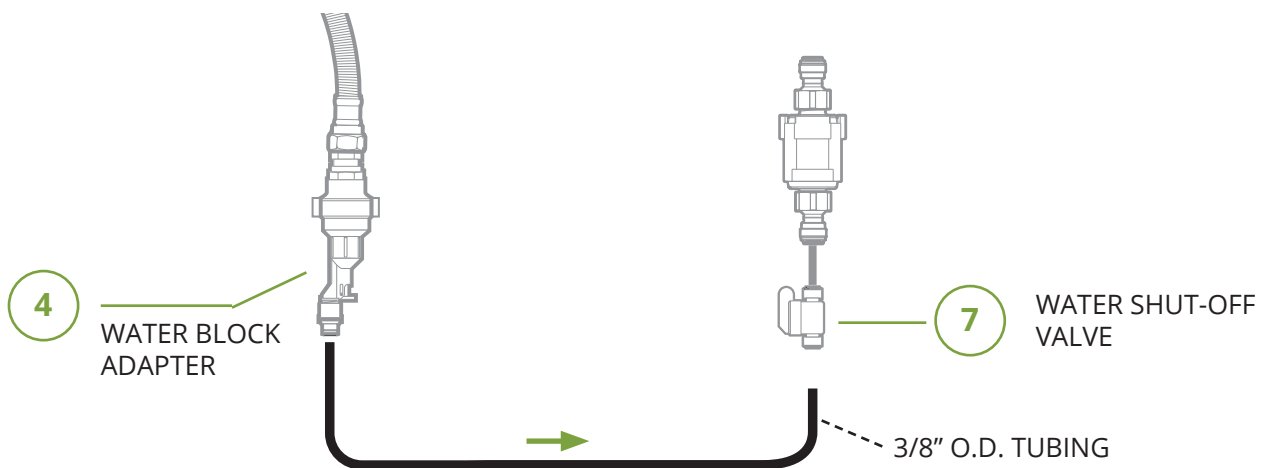

1. Cut 3/8" O.D. tubing to appropriate length.
2. Connect the 3/8" O.D. tube from the 3/8" exit port on the Water Block Adapter to the 3/8" inlet port on the Water Shut Off Valve.

12. CO₂ SUPPLY SYSTEM INSTALLATION:

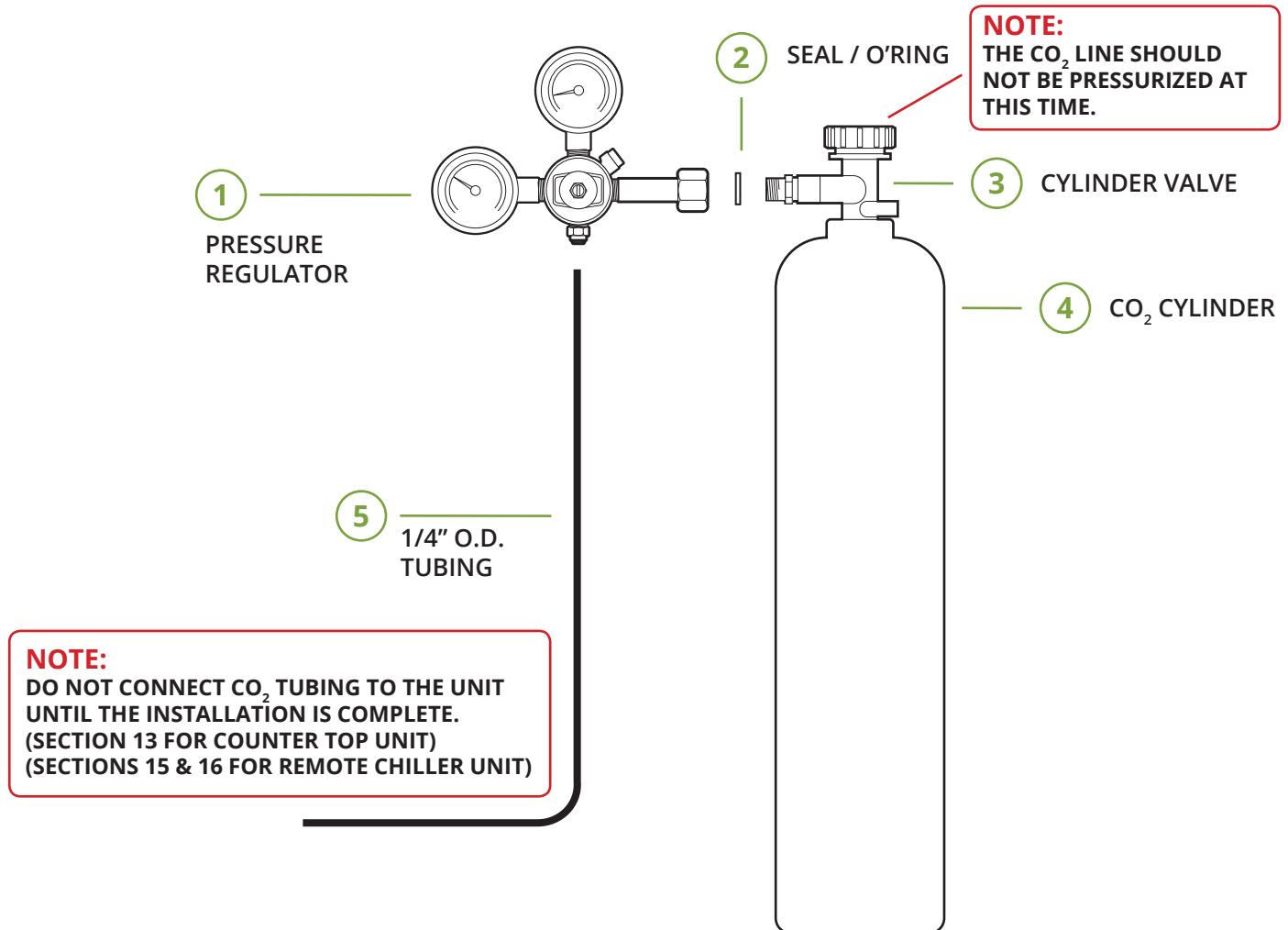

1. Use only food grade CO₂ (UN1013).
2. Place the CO₂ Cylinder within 5 feet of the Countertop Water Dispenser or Remote Chiller.
3. Use a small chain or strap to secure the CO₂ Cylinder to a secure support.
4. To ensure no debris in the CO₂ Cylinder Valve, and that the CO₂ Cylinder is operational, open the valve slowly to allow some CO₂ gas to leak out for a few seconds. Close the CO₂ Cylinder Valve
5. Attach the Pressure Regulator to the Cylinder Valve and tighten it firmly. Ensure that the supplied Seal/ O-ring is between the CO₂ Cylinder Valve and Pressure Regulator fitting.
6. Connect the 1/4" O.D. tubing to the CO₂ Pressure Regulator outlet fitting.
7. Proceed to Section 13 for Counter Top Model Installation, or Sections 15 & 16 for Remote Chiller Model Installation.

13. COUNTER TOP MODEL INSTALLATION:

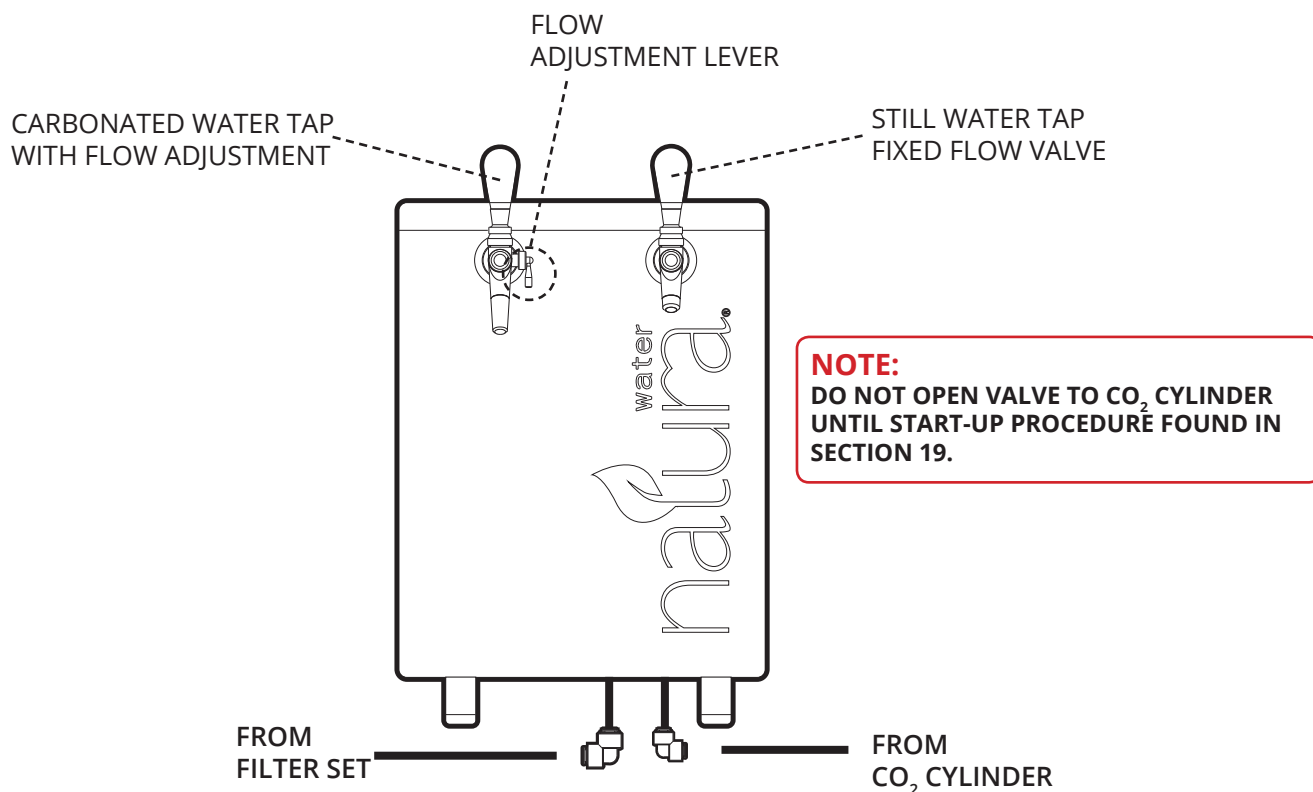

1. Connect the 3/8" O.D. water tube from the exit port of the Filter Set into the 3/8" Elbow Fitting at the rear of the unit.
2. Connect the 1/4" O.D. CO₂ tube from the CO₂ Cylinder Pressure Regulator to the 1/4" Elbow Fitting at the rear of the unit.

14. COUNTER TOP MODEL TAP INSTALLATION:

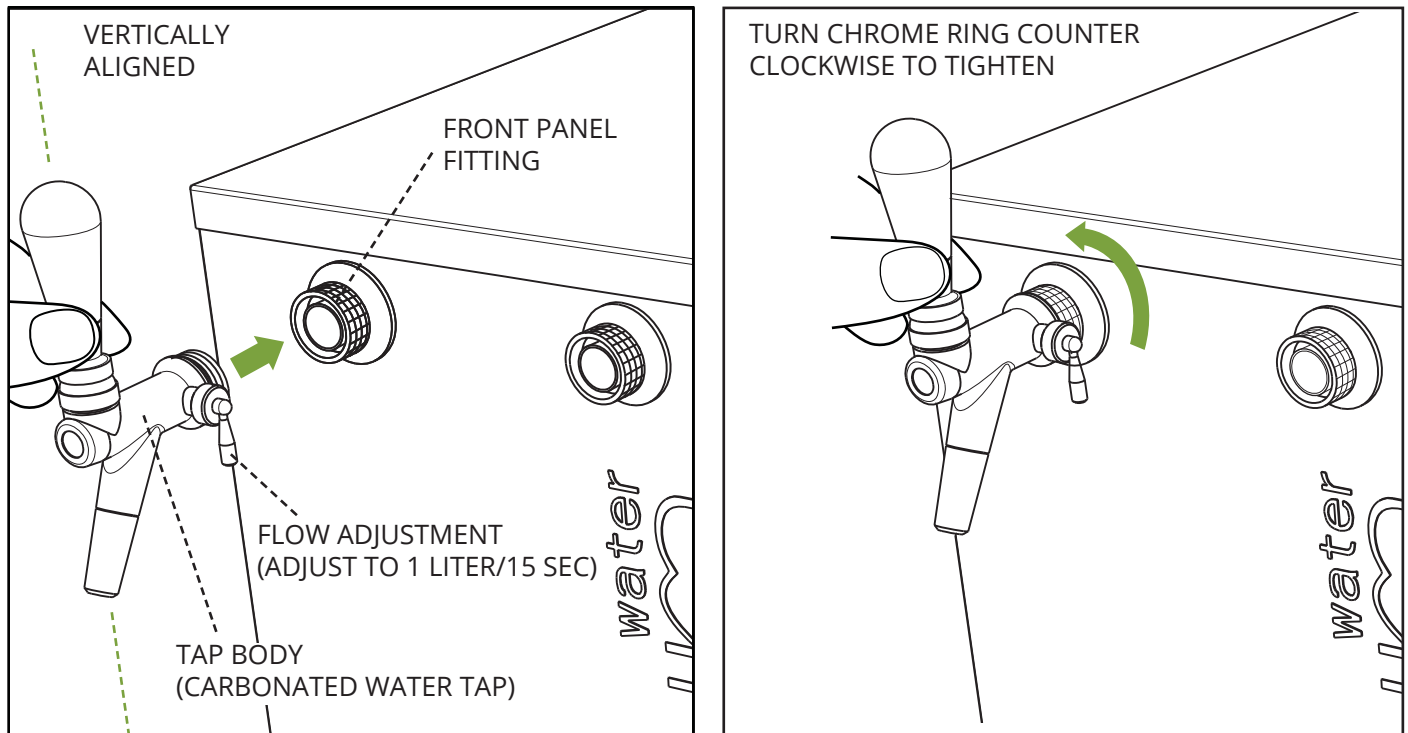

1. Locate the two Taps. They are in the top pad of the packaging.
2. Starting on the left, install the Carbonated Water Tap with Flow Adjustment.
3. Place the Tap into the front panel fitting. Ensure the Tap is aligned vertically. Push the Tap all the way back into the fitting.
4. Screw the Front Panel Fitting to the Tap body. To tighten, turn the chrome ring on the Front Panel Fitting counter clockwise.
5. The Tap should have a tight fit with the front panel fitting.
6. Repeat this process with the Still Water Tap. It assembles on the right side.
7. Proceed to Section 18.

15. REMOTE CHILLER MODEL SHANK ASSEMBLY:

WATER DISPENSE SYSTEM

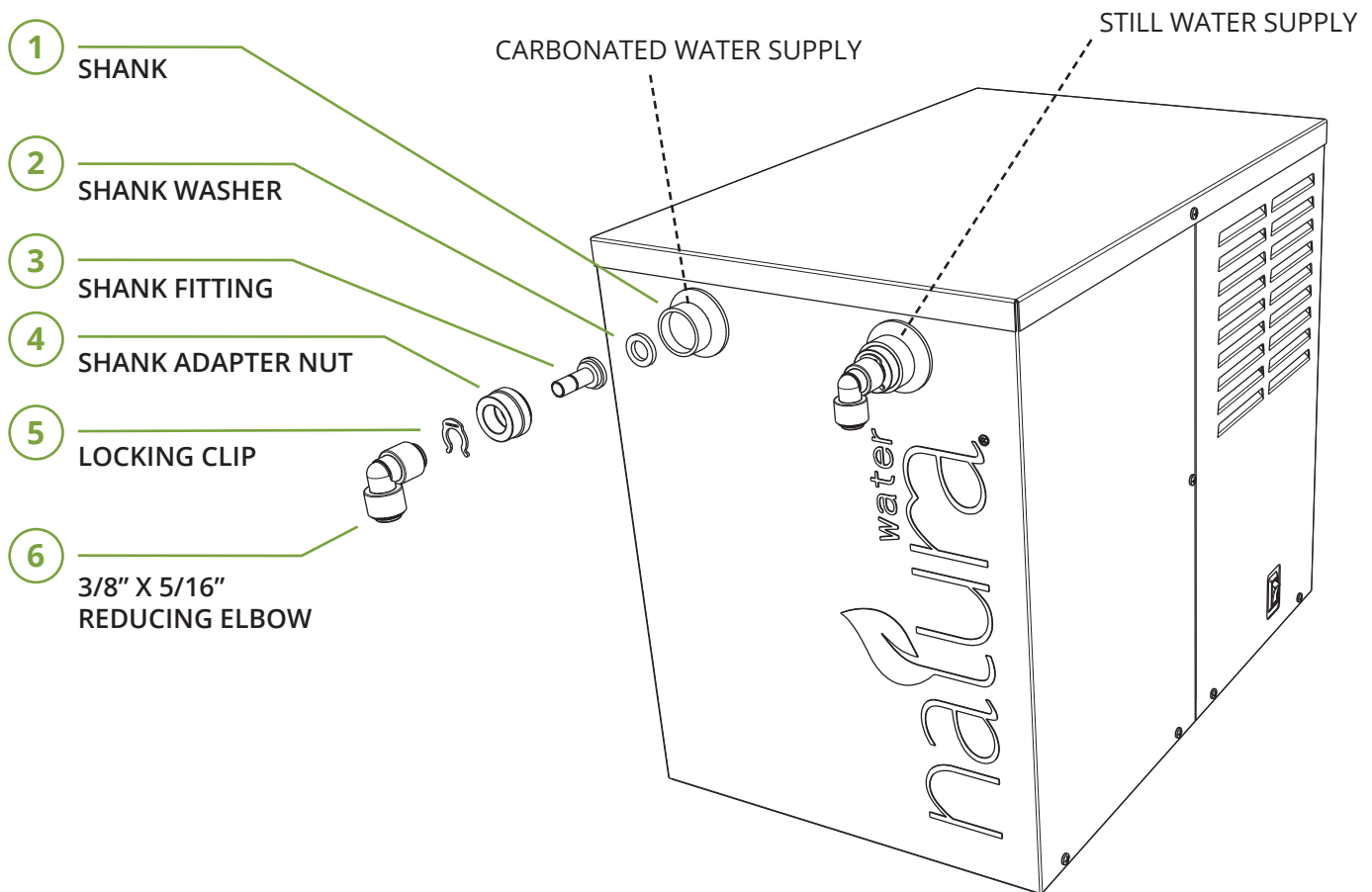

1. Assemble the Shank Washer, Shank Fitting, Shank Adapter Nut, Locking Clip, and Reducing Elbow as show in the illustration above.
2. The Shank Adapter Nut should be hand tightened and checked for leaks during startup.
3. It is important to install the Locking Clip on the Reducing Elbow as shown.

16. REMOTE CHILLER MODEL INSTALLATION:

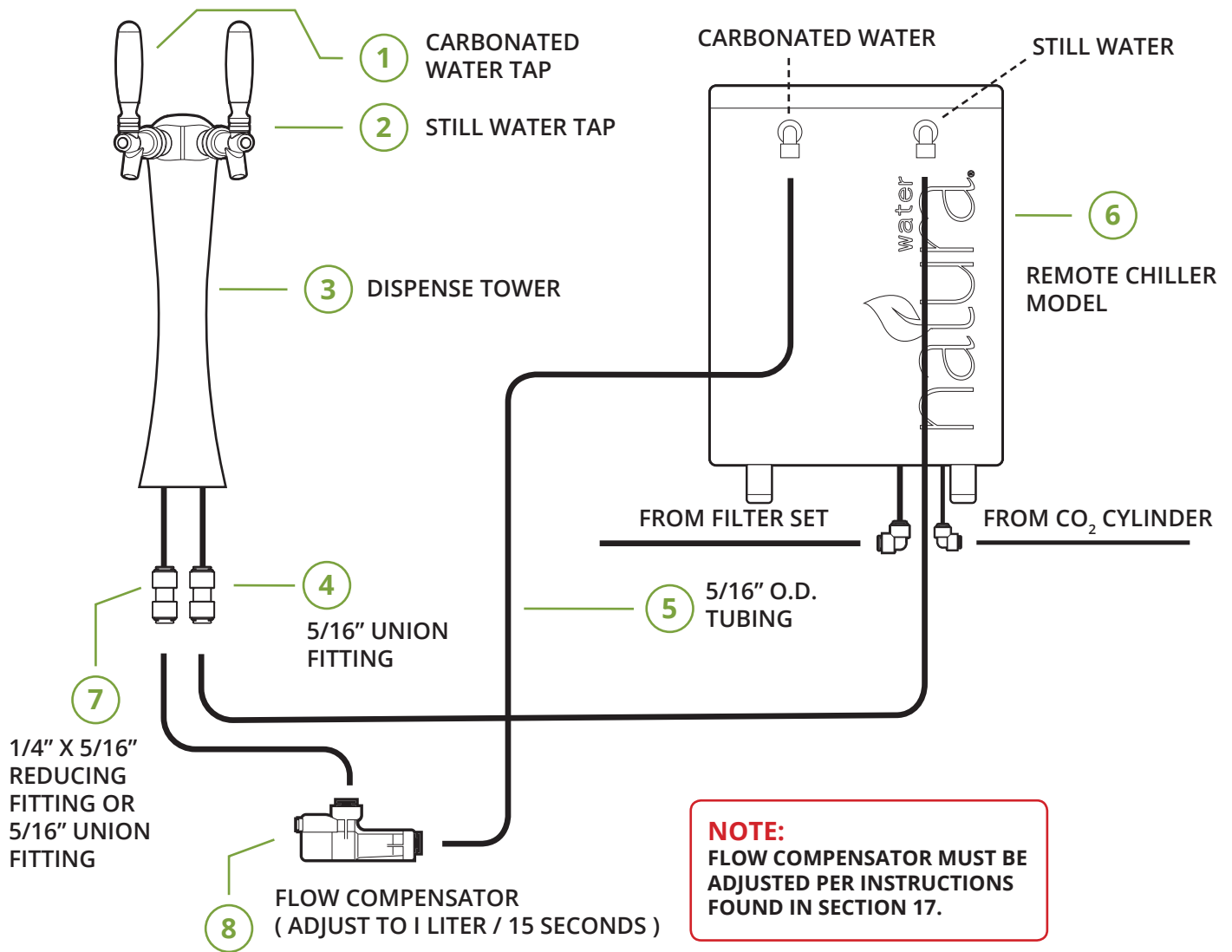

Remote Chiller Model Installation- Connection of the Carbonated Water Tubing.

1. Insert the 5/16" O.D. tubing into the tubing insulation provided.
2. Connect the 5/16" O.D tubing to the left elbow quick connect fitting on the front of the unit.
3. Connect the other end of the 5/16" O.D. tubing to the inlet of the Flow Compensator.
4. Connect the outlet of the Flow Compensator to the left side union fitting on the Dispense Tower. Note: This fitting may be a 1/4" x 5/16" reducing fitting or 5/16" union fitting depending on the Dispense Tower model.

Remote Chiller Model Installation- Connection of the Still Water Tubing.

1. Insert the 5/16" O.D. tubing into the tubing insulation provided.
2. Connect the 5/16" O.D. tubing to the right elbow quick connect fitting on the front of the unit.
3. Connect the other end of the tubing to the 5/16" Union Fitting on the right side of the Dispense Tower. Note: This fitting may be a 1/4" x 5/16" reducing fitting or a 5/16" union fitting depending on the Dispense Tower model.

Remote Chiller Model- Connection of CO₂ gas and Water Supply Line.

1. Connect the 1/4" O.D. CO₂ tube from the CO₂ Cylinder Pressure Regulator to the 1/4" elbow fitting at the rear of the unit.
2. Connect the 3/8" O.D. tubing from the Filter Set into the 3/8" elbow fitting at the rear of the unit.
3. IMPORTANT: INSTALL LOCKING CLIPS TO ALL PUSH TYPE FITTINGS.

17. FLOW COMPENSATOR ADJUSTMENT (FOR REMOTE CHILLER MODEL ONLY)

The CO₂ water flow has been factory-set to provide the proper flow rate of approximately 1 liter/15 sec. However, it may be necessary to adjust this in the field.

To adjust the flow, insert a 6mm Allen wrench into the adjustment screw of the Compensator Valve.

Turning clockwise, the flow rate will decrease. Turning counter-clockwise the flow rate will increase.

It is recommended to adjust the valve approximately ½ turn each time. A proper setting is important for correct carbonation level.

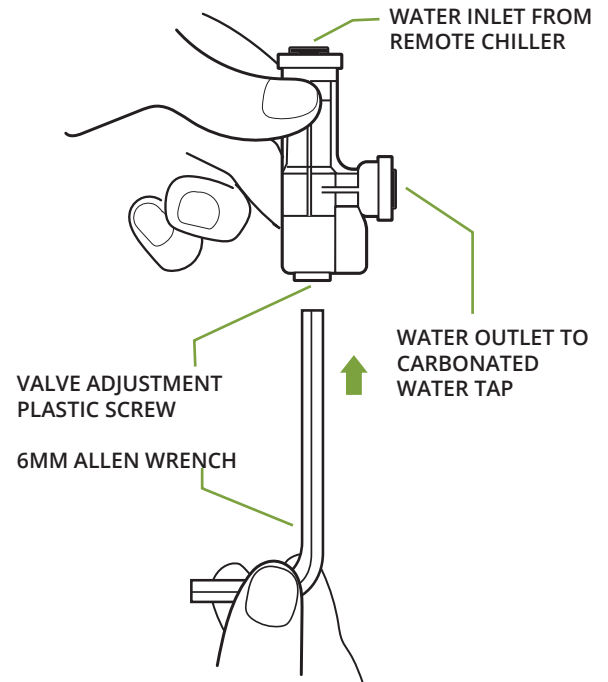

18. WATER LEAK PROTECTION DEVICE ADJUSTMENT

WATER INLET FROM MAIN WATER SOURCE.

WATER LEAK PROTECTION DEVICE MUST BE INSTALLED IN THE VERTICAL POSITION FOR PROPER OPERATION.

EXTERNAL RESET TRIGGER PUSH TO RESET.

WATER OUTLET TO WATER SHUTOFF VALVE.

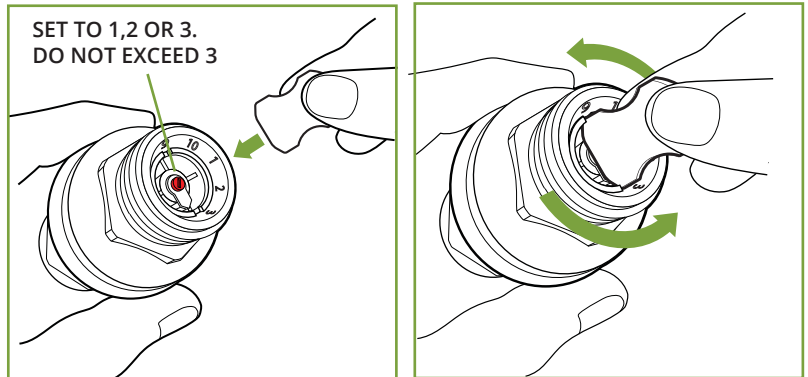

WATER LEAK PROTECTION ADJUSTMENT KEY.

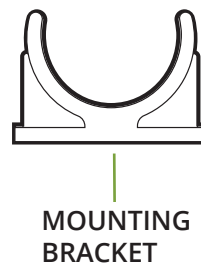

IMPORTANT:
PROPER INSTALLATION OF THE WATER LEAK PROTECTION DEVICE IS REQUIRED OR WARRANTY WILL BE VOIDED.

IF NOT INSTALLED PROPERLY CONSUMER WILL BE RESPONSIBLE FOR ANY DAMAGES.

The Water Leak Protection Device is an overflow safety device that controls the maximum consumption of water between 5 and 50 liters.

Its function is to measure the volume of water that passes through it. If this volume exceeds the set value, the Water Leak Protection Device stops the flow and stays in the safety condition until user intervention.

1. The device should be installed in a vertical orientation directly to the outlet port of the Braided Hose
2. All connections are the “face seal” type, and should not be over tightened.
3. The device is equipped with a valve adjustment.
4. To adjust the device, separate the two black plastic housings.
5. The adjustment location is on the external threaded end of the main housing.
6. Insert the key provided into the adjustment slot .
7. Turn the key until the valve is set at 1, 2, or 3. Do not exceed 3. This setting controls the amount of water that is permitted to flow before the device trips and stops the water flow.
8. Reassemble the two black plastic housings.

Water Leak Protection Device Reset

The Water Leak Protection Device is supplied with a Reset Adapter. This allows you to reset the device if it has nuisance cycled. For example, filling a stock pot (more than 3 gallons) without a pause.

To reset, simply push the red Reset Trigger. Due to line pressure, it may require some force to depress the red Reset Trigger.

19. STARTUP PROCEDURE:

1. Remove the two lid screws and the Lid to access the inside of the unit.
2. Make sure that all of the water and CO₂ connections have been made.
3. Open the Water Shut Off Valve and check the system for leaks.
4. Open the Pressure Relief Valve located on the carbonator tank by pushing down on the Pressure Relief Ring as shown below. Keep it open until water flows from the valve then close it.

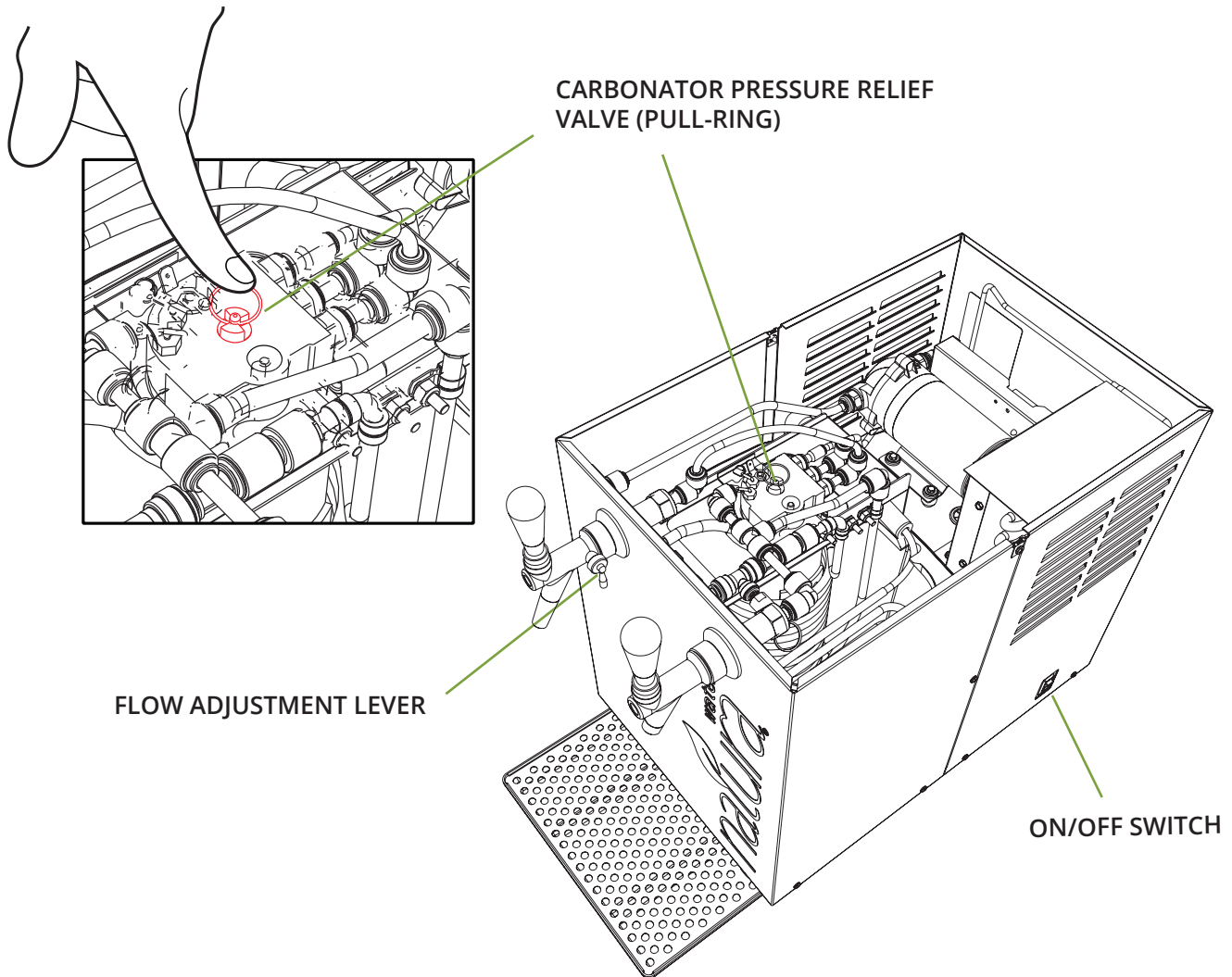

5. Draw 2 gallons of water from each tap to clear the lines and flush the newly installed filters.
6. Slowly open the CO₂ Cylinder Valve completely and adjust the pressure at the Cylinder Regulator with a target of 60 PSI and a maximum of 65 PSI. Check for leaks.

- Fill the Insulated Reservoir with distilled or de-ionized water. Have 5 Gallons available. Fill to the level shown. Carefully fill until the water level is just below the Condensation Overflow Outlet.

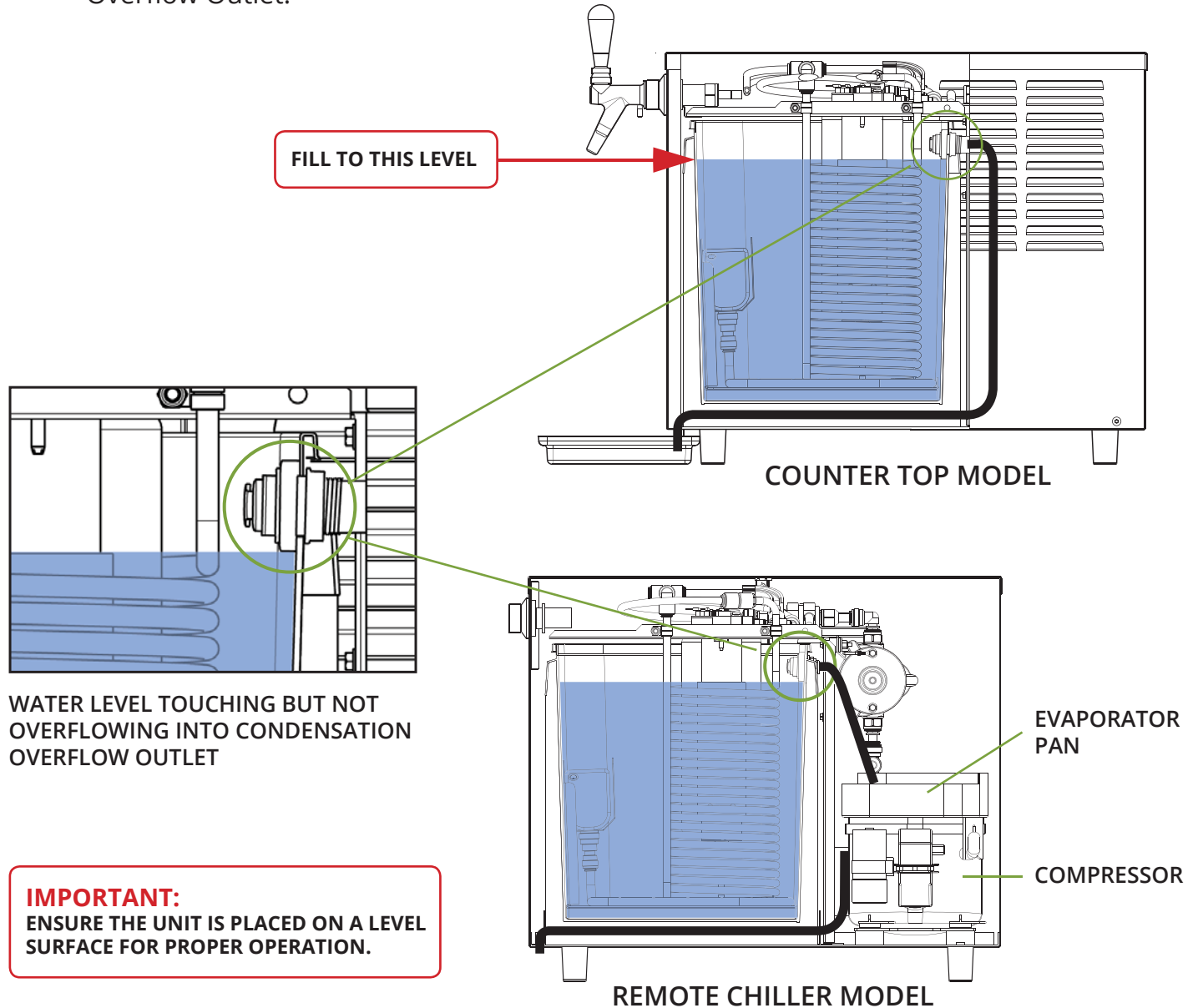

- Replace the top and secure with the two screws.
- Plug in the unit to a suitable electrical outlet.
- Turn the power switch to the ON position. The switch will illuminate to indicate that the power is on.
- Adjust the CO₂ water flow (Left Tap) to 1Liter/15 sec flow rate using the Flow Adjustment Lever located on the side of the Tap body. This is important for correct carbonation level.
- Before using the unit, allow it to finish at least one refrigeration cycle (about 3-4 hours).

20. DRIP TRAY PLACEMENT:

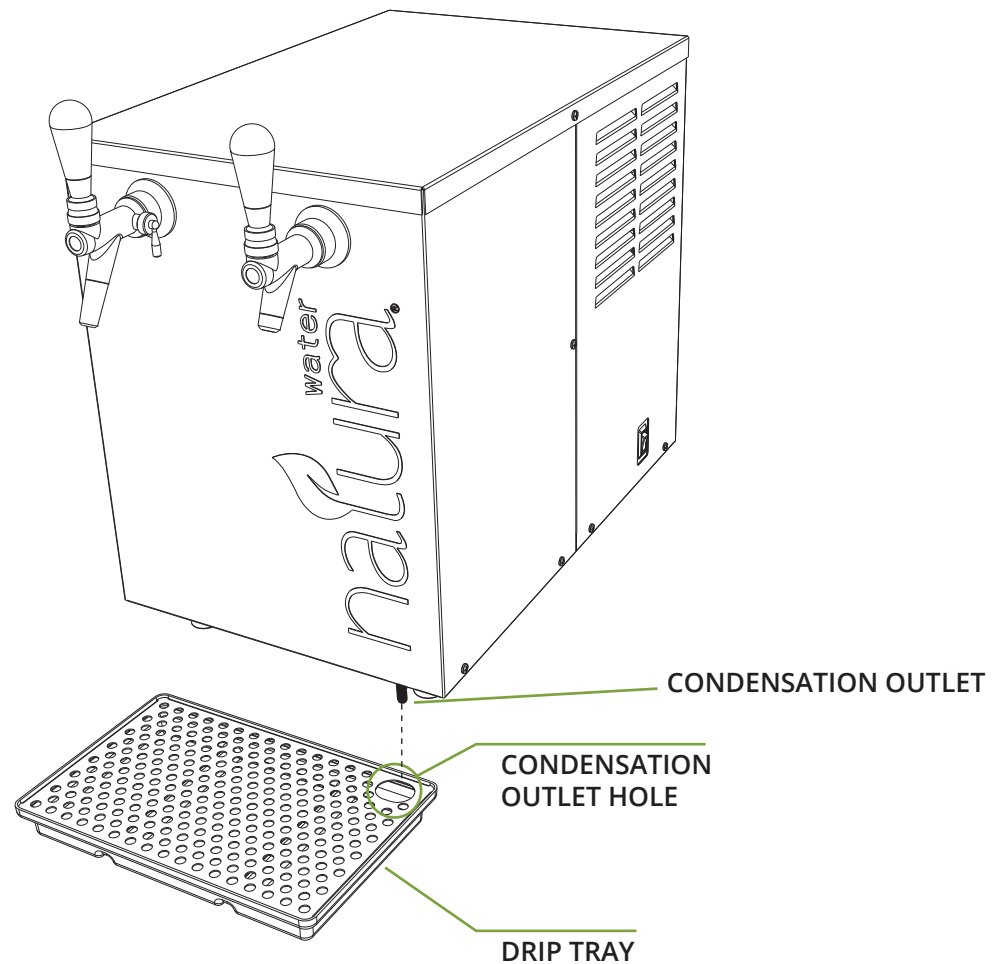

The Drip Tray supplied with your Natura product is designed to collect condensation that accumulates during normal operation of the unit.

The Condensation Outlet is located on the bottom of the machine about 1 inch from the front right corner.

The Drip Tray has a large hole to allow condensation to run freely into the drip tray.

For this hole to be aligned properly, the Drip Tray must be centered left to right and pushed all the way back to make contact with the front feet.

The Remote Chiller Model does not have a Drip Tray, so in extremely humid conditions, a drip pan (not included) should be placed under this drain tube and emptied regularly.

21. FILTER REPLACEMENT:

1. The Filters should be replaced every 6 months or before 10,000 gallons of water usage.
2. Turn off the main water supply and disconnect the power from the unit.
3. Open the Still Water Faucet (right side faucet) to release water pressure from the line.
4. Unscrew the Filter Housing counter clockwise to remove it to access the Filter. Be aware of water spillage when turning the housing.
5. Remove the used Filter and discard.
6. When opening the Filter Housing to change the Filter, it is common for the O-ring to lift out of the housing and stick to the housing cap.
7. Remove the O-ring from the Filter Housing.
8. Clean the inside of the Filter Housing. Fill the housing with tap water and add 1 to 2 tablespoons of bleach. Scrub with a brush or sponge. Rinse thoroughly with clean water.
9. Clean the O-Ring groove and O-ring. Lubricate the O-ring with food grade silicone grease. Place the O-ring back into the housing groove. NOTE: This step is important to ensure a proper seal. Make sure the O-ring is seated level in the groove. CAUTION: If O-ring appears damaged or crimped it should be replaced.
10. Assemble the new Filters. Ensure that they slip down over the housing standpipe. The Pre-Sediment Filter (white) installs in the left (inlet) side housing. The Carbon Filter (black with netting) installs in the center housing. The NanoCeram® Filter (pleated with netting) installs in the right (outlet) housing.
11. Screw the housings onto the Filter Manifold and hand tighten. DO NOT OVER-TIGHTEN.
12. Turn on the main water supply line and check for any leaks.
13. Dispense 3 – 4 gallons of water from the right side tap to flush the Filters.
14. Resume electrical power to the unit.

22. MAINTENANCE:

1. Unplug the electric power connection, and shut off the water supply and CO₂ supply during maintenance or malfunction of the unit.
2. The faucets and nozzles of the counter top unit should be wiped off on a daily basis with a clean cotton rag or non-abrasive sponge and hot water.
3. The Drip Tray should be emptied and cleaned with hot water on a daily basis. Be sure to replace the Drip Tray to its proper location to collect condensation overflow during normal machine operation.
4. If using the 2 Tap Dispensing Tower, the tower, faucets, and nozzles should be wiped off on a daily basis with a clean cotton rag or non-abrasive sponge and hot water.
5. The 2 Tap Dispensing Tower Drip Tray should be emptied and cleaned with hot water on a daily basis. Be sure to replace the Drip Tray to its proper location.
6. The external stainless steel surface of the cabinet should be cleaned and polished periodically with a non-abrasive cleaning solution or metal cleaner and a soft cotton cloth.
7. When the CO₂ regulator gauge needle moves to the red section of the gauge, it is necessary to replace the CO₂ Cylinder to avoid disruption of the sparkling water supply. **IMPORTANT: IF THE CO₂ CYLINDER IS LOW OR EMPTY, THE CARBONATION LEVEL WILL BE LOW.**
8. Check the heat exchange water reservoir monthly. Add distilled or de-ionized water until the water level is just below the Condensation Overflow Outlet. **DO NOT** fill to the very top of the Reservoir. **NOTE:** Unplug the electric power before performing this maintenance.
9. Also view website for maintenance suggestions. (www.naturawater.com)



MAINTENANCE RECORD

SERIAL # _____ MODEL # _____

LOCATION : _____

SERVICE DATE:	SERVICE TECHNICIAN	SIGNATURE	DESCRIPTION



23. SPARE PARTS DRAWING - MODEL NWSB SER.4

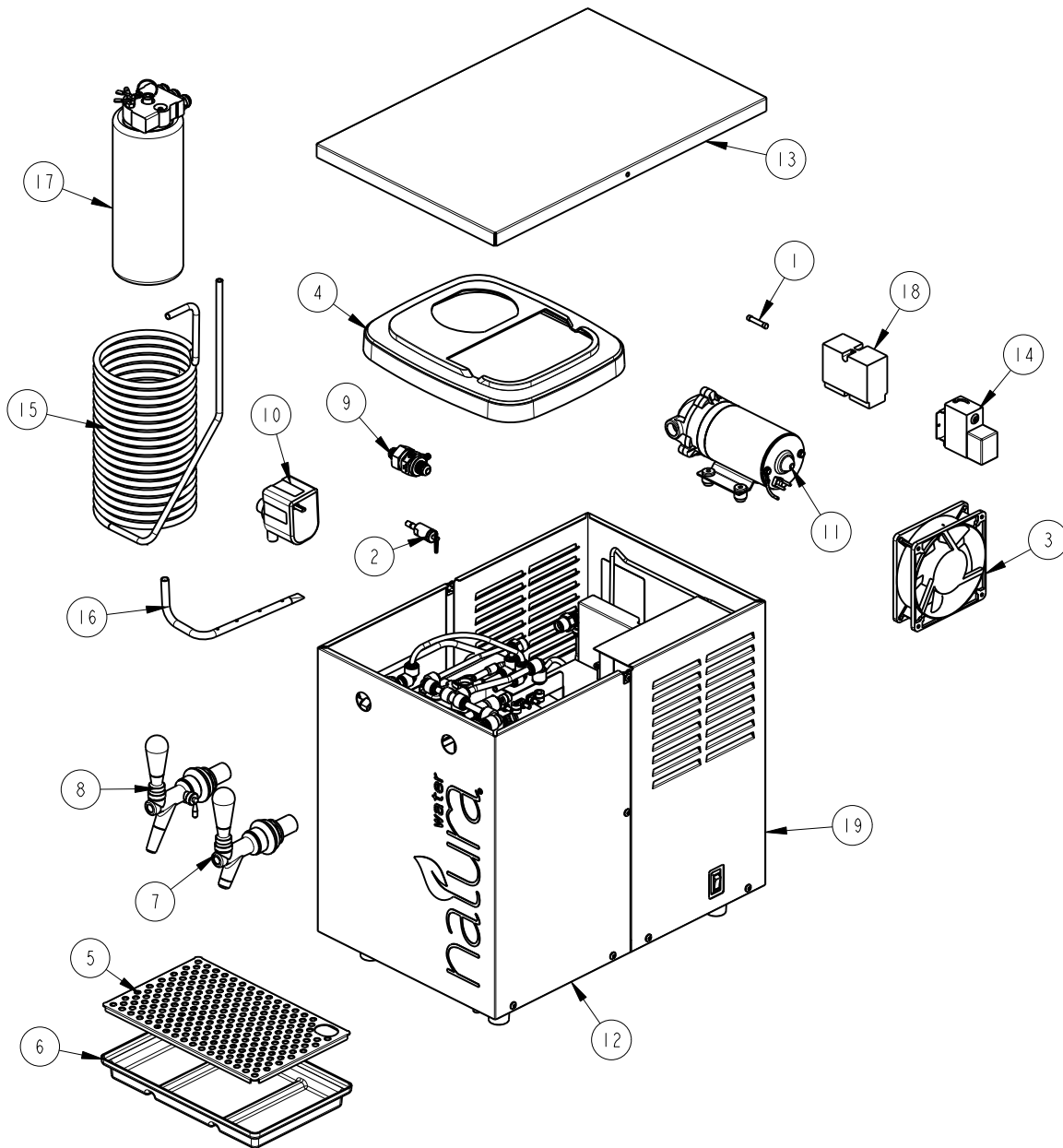

Model NWSB SER.4

ITEM	PART NO.	DESCRIPTION
1	029191-004	FUSE, 1.25A
2	034949P999	PRESSURE RELIEF VALVE
3	035545-004	CONDENSER FAN
4	036247-016	PLASTIC LID
5	036287-013	DRIP TRAY GRILL
6	036289-012	DRIP TRAY
7	036311-201	STILL WATER TAP ASSY.
8	036311-202	CO2 COMPENSATED TAP ASSY.
9	036387-003	BACKFLOW PREVENTER
10	036535-004	STIRRING PUMP

ITEM	PART NO.	DESCRIPTION
11	036544-102	WATER PUMP
12	038324-001	FRONT PANEL
13	038327-001	TOP
14	038343-002	ICE BANK CONTROL
15	038359-003	WATER COIL
16	038396-001	STIR TUBE
17	038624-001	CARBONATOR TANK
18	038634-001	LIQUID LEVEL CONTROL
19	038642-001	BACK PANEL

24. SPARE PARTS DRAWING - MODEL NWSBU2 SER.4

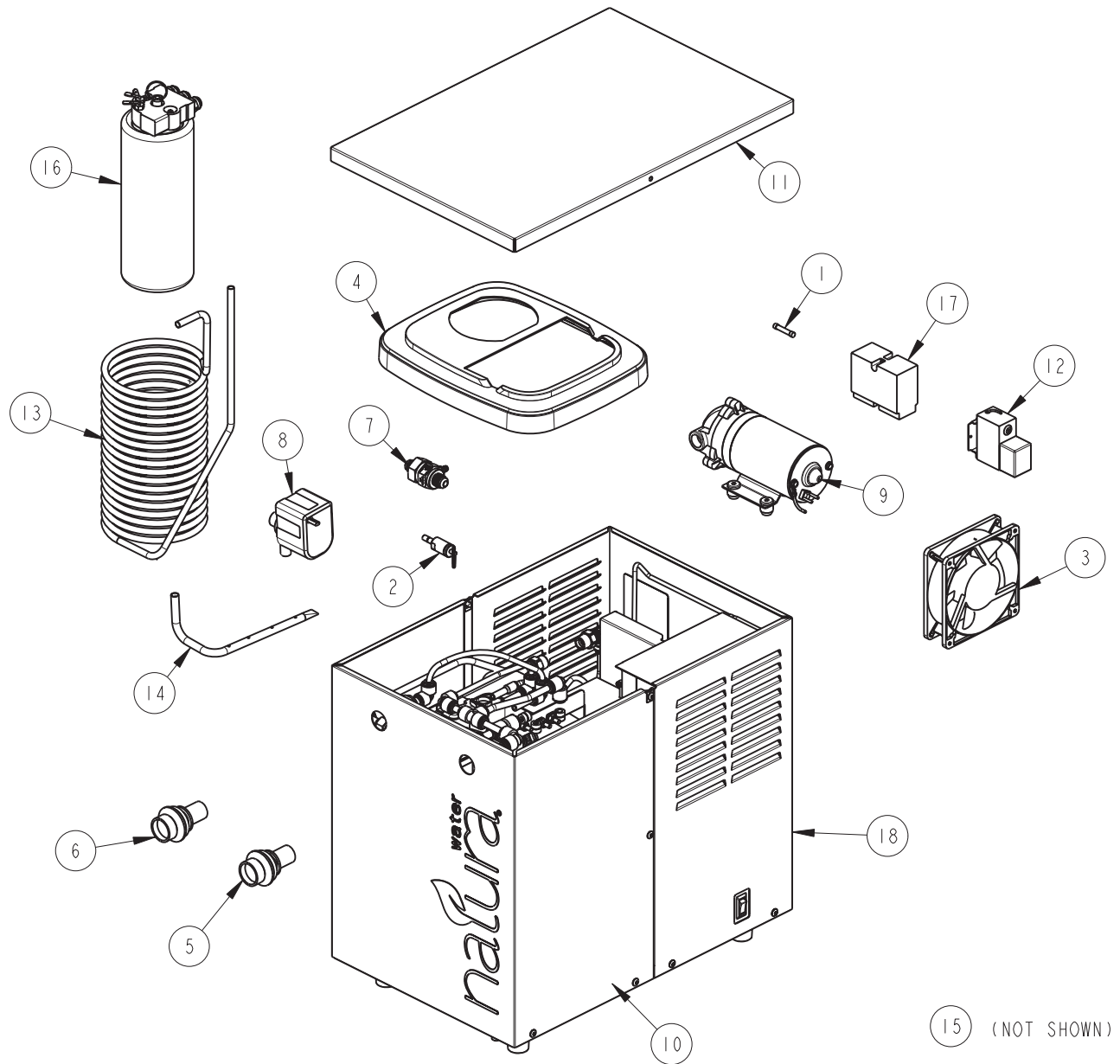

Model NWSBU2 SER.4

ITEM	PART NO.	DESCRIPTION
1	029191-004	FUSE, 1.25A
2	034949P999	PRESSURE RELIEF VALVE
3	035545-004	CONDENSER FAN
4	036247-016	PLASTIC LID
5	036311-207	STILL WATER SHANK ASSY.
6	036311-208	CO2 COMPENSATED SHANK ASSY.
7	036387-003	BACKFLOW PREVENTER
8	036535-004	STIRRING PUMP
9	036544-102	WATER PUMP
10	038324-004	FRONT PANEL

ITEM	PART NO.	DESCRIPTION
11	038327-004	TOP
12	038343-002	ICE BANK CONTROL
13	038359-003	WATER COIL
14	038396-001	STIR TUBE
15	038414T002	2 & 3 TAP DISPENSE TOWER INSTALL KIT
16	038624-001	CARBONATOR TANK
17	038634-001	LIQUID LEVEL CONTROL
18	038642-004	BACK PANEL

25. TROUBLESHOOTING:

PROBLEM	POSSIBLE CAUSE	SUGGESTION
Unit not working.	- No power.	- Check the power outlet, plug connection, and the circuit breaker. Power switch is "ON".
The refrigeration system is working but the agitator has stopped.	- The agitator motor has failed.	- Replace agitator.
The refrigeration system is not cooling the water (the fan, compressor, and agitator are all working).	- No refrigerant gas. - Over usage. - Dispensing more water than machine rated capacity.	- Contact Technical assistance.
The refrigeration system is not cooling the water (the fan has stopped, but the compressor and agitator are still working).	- Condenser fan malfunction or seized due to excessive accumulation of lint.	- Clean or replace the motor/fan.
The refrigeration system is not cooling the water (the fan and compressor have stopped, the agitator is still working).	- Thermostat fault. - Ice bath in Reservoir: Insufficient water level in Reservoir.	- Check thermostat. - Add water to the Reservoir.
The refrigeration system is not cooling the water (the compressor has stopped, the fan and agitator are still working).	- The thermal compressor protector has been activated. - Compressor relay is in short circuit. - Compressor defective.	- Turn off the power, wait for 15 to 20 minutes, switch power back on. If problem persists call a service technician. - Replace the relay. - Replace the compressor.
The refrigeration system never stops and the water is solid ice.	- The thermostat fault. - Room temperature too hot.	- Replace the thermostat. - Move machine to lower temperature room.
The carbonator water pump makes a loud noise.	- Water pressure or supply is insufficient due to clogged Filters. - Main water supply valve for the filter set to minimum. - Loose mounting screws.	- Replace Filters. - Check the supply valve and open to the maximum setting. - Check the mounting screws and tighten if necessary.
The water temperature comes out warm.	- Thermostat fault. - Insufficient water level in the Reservoir. - Agitator has stopped. - Over usage. - Dispensing more water than machine rated capacity.	- Replace thermostat - Add water to the Reservoir. - Restart the unit or replace the agitator.

PROBLEM	POSSIBLE CAUSE	SUGGESTION
The water has an unusual taste.	<ul style="list-style-type: none"> - Filters clogged. - CO₂ used was not for drinking water. - Incoming water quality 	<ul style="list-style-type: none"> - Replace Filters. - Check the type of CO₂ (UN 1013). If necessary, change the tank. - Clean & Sanitize the faucets.
Water is not sufficiently carbonated.	<ul style="list-style-type: none"> - CO₂ pressure is too low. - CO₂ Cylinder is empty. - Incorrect functioning of the pump and motor. - Accumulation of air in the carbonator tank. 	<ul style="list-style-type: none"> - Adjust the pressure regulator so that CO₂ pressure is between 60 to 65 PSI. - Replace the CO₂ Cylinder. - Check that the motor and pump are working well. - Let the air out by lifting the black lever on the head of the carbonator tank's pressure relief valve for 1 to 2 seconds.
CO₂ gas runs out too fast	<ul style="list-style-type: none"> - There may be a leak in the supply line, connectors or valve. 	<ul style="list-style-type: none"> - With a paintbrush, soap and water, wash the external lines tubing of the CO₂ Cylinder so as to pinpoint the leakage. - Replace defective valve, regulator/gasket or tubes.
CO₂ gas comes out of the carbonated water faucet (green handle).	<ul style="list-style-type: none"> - CO₂ water dispenses too fast. - Insufficient water supply. - Filters clogged - Water pump not working. - CO₂ tank float switch fault. 	<ul style="list-style-type: none"> - Adjust Flow Compensator Valve to proper dispense setting (1 liter/15 sec). - Replace Filters. - Check or replace the water pump. - Check CO₂ tank float switch.
Carbonated water squirts out of the still water faucet.	<ul style="list-style-type: none"> - Still faucet from CO₂ tank check valve, possibly stuck open. 	<ul style="list-style-type: none"> - Clean or replace if defective.
Water does not come out of the faucet.	<ul style="list-style-type: none"> - The water is frozen around the coils. - Water tubes are kinked. - The Flow Compensator Valve is in closed position. - Water Leak Protection Device tripped. 	<ul style="list-style-type: none"> - If ice has formed in the Reservoir and is touching the water coil, check agitator motor. - Verify plumbing supply line to machine is not pinched or kinked. - Adjust Flow Compensator Valve to proper dispense setting (1 liter/15 sec). - Reset by depressing red lever on Water Leak Protection Device.
Water comes out very slowly.	<ul style="list-style-type: none"> - Water tubes are kinked. - Water shut-off valve closed or set to minimum. - Sediment or Carbon Filter blocked or excessively dirty. - Water pressure is too low. - Water pressure valve regulator malfunction. 	<ul style="list-style-type: none"> - Check and clean the tubes. - Open completely the water supply line shut-off valve. - Replace Filters. - Check the water pressure to the unit (pressure should be no less that 45 PSI). - Check the main water supply line.

26. CONTACT INFORMATION:

TECHNICAL ASSISTANCE AND MAINTENANCE

For technical support, contact the Technical Service Department, Distributor or Vendor of the unit. Or you may contact:

NATURA Water LLC.
222 East Campus View Blvd
Columbus, Ohio 43235
1-877-302-8638
www.naturawater.com

036333-013 REV. C

Natura is a registered trademark of Natura, Inc.
© 2017 Natura, Inc.
