

INSTALLATION INSTRUCTIONS

T4BE - 018, 024, 030, 036, 042, 048, & 060 (1.5, 2, 2.5, 3, 3.5, 4, & 5 Ton) Series SINGLE PHASE MODELS

IMPORTANT SAFETY INFORMATION	2	HEAT PUMP MAINTENANCE	9
HEAT PUMP INSTALLATION	3	REFRIGERANT CHARGING	10
General Information	3	Charging the Unit in AC Mode with	
Before You Install this Unit	3	Outdoor Temperatures Above 55° F	10
Locating the Heat Pump	3	CHARGING CHARTS - COOLING MODE	11
Packaging Removal	3	Figure 6. Charging Chart for 1.5 Ton Units	11
Ground Level.....	3	Figure 7. Charging Chart for 2 Ton Units	12
Rooftop	3	Figure 8. Charging Chart for 2.5 Ton Units	12
Connecting Refrigerant Tubing Between the		Figure 9. Charging Chart for 3 Ton Units	13
Indoor & Outdoor Unit	4	Figure 10. Charging Chart for 3.5 Ton Units	13
Outdoor Orifice Removal & Installation	4	Figure 11. Charging Chart for 4 Ton Units	14
ELECTRICAL WIRING	5	Figure 12. Charging Chart for 5 Ton Units	14
Pre - Electrical Checklist	5	CHARGING TABLES - HEATING MODE	15
Line Voltage	5	Table 4. Charging Table for 1.5 Ton Units	16
Grounding	5	Table 5. Charging Table for 2 Ton Units	16
Thermostat / Low Voltage Connections	6	Table 6. Charging Table for 2.5 Ton Units	16
Blower Time Delay Relay	7	Table 7. Charging Table for 3 Ton Units	16
CoreSense™ Diagnostics Module.....	7	Table 8. Charging Table for 3.5 Ton Units	17
Compressor Protection.....	7	Table 9. Charging Table for 4 Ton Units	17
Resetting Alert Codes	7	Table 10. Charging Table for 5 Ton Units	17
STARTUP & ADJUSTMENTS	8	WIRING DIAGRAMS	18
Pre - Start Checklist.....	8	Figure 13. C,M(SH) & D,E,J(T4BE) (1.5-3.5 Ton)	18
Start-up Procedures.....	8	Figure 14. FT4BE Series (1.5-3.5 Ton).....	19
Air Circulation - Indoor Blower	8	Figure 15. PSH4BE Series (1.5-3.5 Ton)	20
Short Cycle Protection Cooling.....	8	Figure 16. C,M(SH) & D,E,J(T4BE) (4 & 5 Ton)	21
System Cooling.....	8	Figure 17. FT4BE Series (4 & 5 Ton).....	22
System Heating.....	8	Figure 18. PSH4BE Series (4 & 5 Ton).....	23
Defrost Cycle Timer	8	INSTALL. / PERFORMANCE CHECKLIST	24
Defrost Control Board	9	REPLACEMENT PARTS	24
Operational Information	9		
Normal Defrost Operation.....	9		
Defrost Test Procedure	9		
Anti Short Cycle Timer Test.....	9		

IMPORTANT

ATTENTION INSTALLERS:

It is your responsibility to know this product better than your customer. This includes being able to install the product according to strict safety guidelines and instructing the customer on how to operate and maintain the equipment for the life of the product. Safety should always be the deciding factor when installing this product and using common sense plays an important role as well. Pay attention to all safety warnings and any other special notes highlighted in the manual. Improper installation of the furnace or failure to follow safety warnings could result in serious injury, death, or property damage.

These instructions are primarily intended to assist qualified individuals experienced in the proper installation of this appliance. Some local codes require licensed installation/service personnel for this type of equipment. Please read all instructions carefully before starting the installation. Return these instructions to the customer's package for future reference.

DO NOT DESTROY. PLEASE READ CAREFULLY AND KEEP IN A SAFE PLACE FOR FUTURE REFERENCE.

IMPORTANT SAFETY INFORMATION

INSTALLER: Please read all instructions before servicing this equipment. Pay attention to all safety warnings and any other special notes highlighted in the manual. Safety markings are used frequently throughout this manual to designate a degree or level of seriousness and should not be ignored. **WARNING** indicates a potentially hazardous situation that if not avoided, could result in personal injury or death. **CAUTION** indicates a potentially hazardous situation that if not avoided, may result in minor or moderate injury or property damage.

WARNING:

ELECTRICAL SHOCK, FIRE OR EXPLOSION HAZARD

Failure to follow safety warnings exactly could result in serious injury or property damage.

Improper servicing could result in dangerous operation, serious injury, death or property damage.

- Before servicing, disconnect all electrical power to the indoor blower.
- When servicing controls, label all wires prior to disconnecting. Reconnect wires correctly.
- Verify proper operation after servicing.

WARNING:

T4BE Split System Heat Pumps are shipped charged with R410A refrigerant and ready for installation. If repairs make it necessary for evacuation and charging, it should only be attempted by qualified trained personnel thoroughly familiar with this equipment. Under no circumstances should the owner attempt to install and/or service this equipment. Failure to comply with this warning could result in property damage, personal injury, or death.

CAUTION:

This unit uses R-410A refrigerant. DO NOT use any other refrigerant in this unit. Use of another refrigerant will damage the unit.

WARNING:

Unless noted otherwise in these instructions, only factory authorized parts or accessory kits may be used with this product. Improper installation, service, adjustment, or maintenance may cause explosion, fire, electrical shock or other hazardous conditions which may result in personal injury or property damage.

- Installation of equipment may require brazing operations. Installer must comply with safety codes and wear appropriate safety equipment (safety glasses, work gloves, fire extinguisher, etc.) when performing brazing operations.
- Follow all precautions in the literature, on tags, and on labels provided with the equipment. Read and thoroughly understand the instructions provided with the equipment prior to performing the installation and operational checkout of the equipment.
- Use caution when handling this appliance or removing components. Personal injury can occur from sharp metal edges present in all sheet metal constructed equipment.

WARNING:

The information listed below and the next page must be followed during the installation, service, and operation of this furnace. Failure to follow safety recommendations could result in possible damage to the equipment, serious personal injury or death.

- The installer must comply with all local codes and regulations which govern the installation of this type of equipment. Local codes and regulations take precedence over any recommendations contained in these instructions. Consult local building codes and the National Electrical Code (ANSI C1) for special installation requirements.
- All electrical wiring must be completed in accordance with local, state and national codes and regulations and with the National Electric Code (ANSI/NFPA 70) or in Canada the Canadian Electric Code Part 1 CSA C.22.1.
- This equipment contains liquid and gaseous refrigerant under high pressure. **DO NOT USE ANY PORTION OF THE CHARGE FOR PURGING OR LEAK TESTING.** Installation or servicing should only be performed by qualified trained personnel thoroughly familiar with this type equipment.
- Fully annealed, refrigerant grade copper tubing should be used when installing the system. Refrigerant suction line tubing should be fully insulated.
- This unit is designed for outdoor installations only and should be positioned as described on page 3.

HEAT PUMP INSTALLATION

General Information

Split system heat pumps are designed only for outdoor rooftop or ground level installations. This unit has been tested for capacity and efficiency in accordance with AHRI Standards and will provide many years of safe and dependable comfort, providing it is properly installed and maintained. Abuse, improper use, and/or improper maintenance can shorten the life of the appliance and create unsafe hazards.

To achieve optimum performance and minimize equipment failure, it is recommended that periodic maintenance be performed on this unit. The ability to properly perform maintenance on this equipment requires certain mechanical skills and tools.

Before You Install the Heat Pump

- ✓ The cooling load of the area to be conditioned must be calculated and a system of the proper capacity selected. It is recommended that the area to be conditioned be completely insulated and vapor sealed.
- ✓ Check the electrical supply and verify the power supply is adequate for unit operation. The system must be wired and provided with circuit protection in accordance with local building codes. If there is any question concerning the power supply, contact the local power company.
- ✓ The indoor section (air handler, furnace, etc) should be installed before routing the refrigerant tubing. Refer to the indoor unit's installation instructions for installation details.
- ✓ All units are securely packed at the time of shipment and upon arrival should be carefully inspected for damage prior to installing the equipment at the job site. Verify coil fins are straight. If necessary, comb fins to remove flattened or bent fins. Claims for damage (apparent or concealed) should be filed immediately with the carrier.
- ✓ Please consult your dealer for maintenance information and availability of maintenance contracts. Please read all instructions before installing the unit.

Locating the Heat Pump

- Survey the job site to determine the best location for mounting the outdoor unit.
- Overhead obstructions (Figure 1), poorly ventilated areas, and areas subject to accumulation of debris should be avoided.
- Sufficient clearance for unobstructed airflow through the outdoor coil must be maintained in order to achieve rated performance. See Figure 1 for minimum clearances to obstructions.
- Consideration should be given to availability of electric power, service access, noise, and shade.

Packaging Removal

To prevent damage to the tubing connections, carefully remove the carton and user's manual from the equipment. Discard the shipping carton.

Ground Level

Ground level installations must be located according to local building codes or ordinances and these requirements:

- Clearances must be in accordance with those shown in Figure 1.
- A suitable mounting pad must be provided and be separate from the building foundation. The pad must be level and strong enough to support the unit's weight. The slab height must be a minimum of 2" (5 cm) above grade and with adequate drainage. See Figure 1.

Rooftop

- The method of mounting should be designed so that it does not overload roof structures or transmit noise to the interior of the structure. The roof must be structurally capable of handling the weight of the unit.
- Full perimeter support is required under the unit. Support must be made of weather resistant materials and installed prior to unit installation.
- The support must be built to raise the unit 6" above the roof.

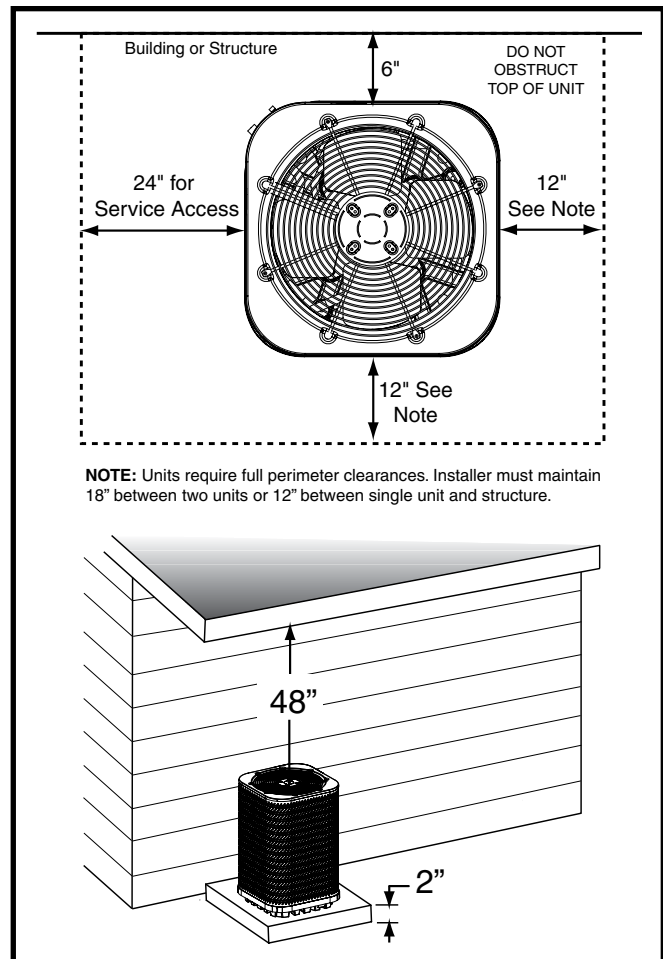

Figure 1. Clearance Requirements

Connecting Refrigerant Tubing Between the Indoor & Outdoor Unit

⚠ CAUTION:

When servicing, cover or seal openings to minimize the exposure of the refrigerant system to air to prevent accumulation of moisture and other contaminants.

After outdoor and indoor unit placement has been determined, route refrigerant tubing between the equipment in accordance with sound installation practices.

- When connecting refrigerant linesets together, it is recommended that dry nitrogen be flowing through the joints during brazing. This will prevent internal oxidation and scaling from occurring.
- Refrigerant tubing should be routed in a manner that minimizes the length of tubing and the number of bends in the tubing.
- Refrigerant tubing should be supported in a manner that the tubing will not vibrate or abrade during system operation.
- Tubing should be kept clean of foreign debris during installation.
- Every effort should be made by the installer to ensure that the field installed refrigerant containing components of the system have been installed in accordance with these instructions and sound installation practices to insure reliable system operation and longevity.
- The maximum recommended interconnecting refrigerant line length is 75 feet, and the vertical elevation difference between the indoor and outdoor sections should not exceed 20 feet.
- If precise forming of refrigerant lines is required, a copper tubing bender is recommended. Avoid sharp bends and contact of the refrigerant lines with metal surfaces.
- A filter dryer is provided with the unit and must be installed in the liquid line of the system. If the installation replaces a system with a filter dryer already present in the liquid line, the filter dryer must be replaced with the one supplied with the unit. The filter dryer must be installed in strict accordance with the manufacturer's installation instructions.
- Optional equipment such as liquid line solenoid valves, low ambient, etc., should be installed in strict accordance with the manufacturer's installation instructions.

Outdoor Orifice Removal & Installation

The orifice installed in the outdoor unit has been sized for use with the most popularly matched indoor units. Depending on the indoor coil that the unit is being matched with, the outdoor restrictor may need to be changed. Please refer to the Quick Reference Data sheet that is supplied with the outdoor unit for more information.

If the outdoor unit has the liquid valve shown in Figure 2 (page 5) then the restrictor is located inside the swivel nut

connection of the liquid valve and not inside the outdoor unit's distributor. Perform steps 1 - 5 if the outdoor restrictor needs to be changed.

⚠ CAUTION:

When servicing, cover or seal openings to minimize the exposure of the refrigerant system to air to prevent accumulation of moisture and other contaminants.

⚠ CAUTION:

To prevent damage to the unit or internal components, it is recommended that two wrenches be used when loosening or tightening nuts. Do not over tighten!

1. Using two wrenches loosen the nut and liquid valve. Turn the assembly nut counter-clockwise until the orifice body halves are separated.

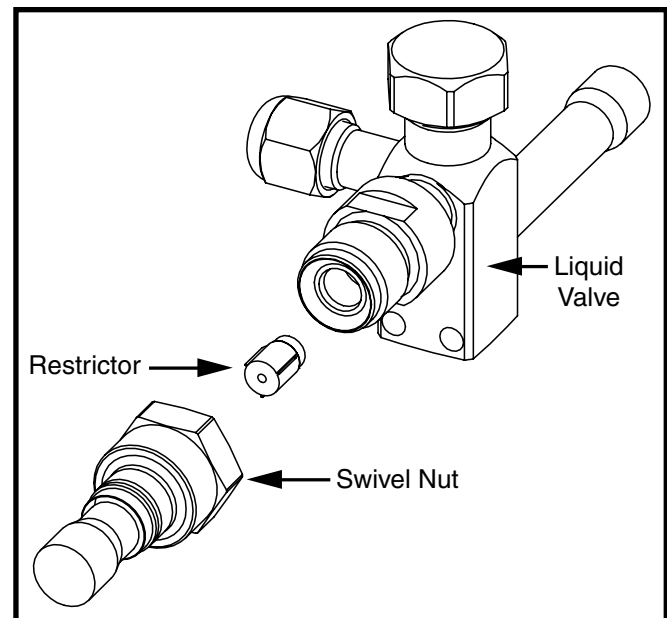

Figure 2. Liquid Valve, Restrictor, & Swivel Nut Adapter

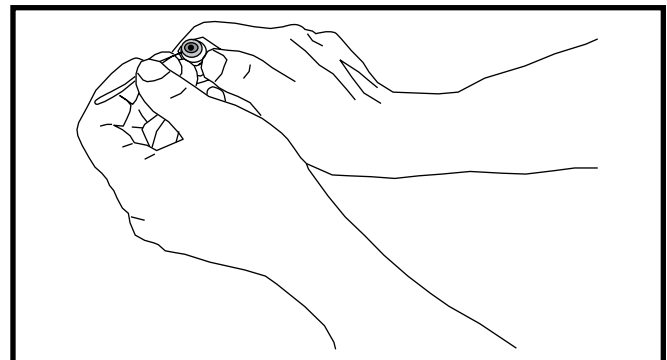

Figure 3. Removal of Orifice

2. Insert a light-gauge wire hook between the valve body and the restrictor orifice (Figure 3, page 5) while being careful not to scratch either part. Carefully remove the restrictor orifice from the valve body.
3. Check the actual size of the new orifice. **NOTE:** The size is stamped on its side. Do not use pin gauges to measure the orifice diameter.
4. Insert the new orifice into the valve body, with the rounded end facing into the valve. See Figure 2.

 **CAUTION:**

To prevent damage to the unit or internal components, it is recommended that two wrenches be used when loosening or tightening nuts. Do not over tighten!

5. Realign the assembly nut on the valve body and hand tighten both components. Mark a line on both bodies and then tighten an additional $\frac{1}{4}$ turn using two wrenches. The movement of the two lines will show how much the nut is tightened.

ELECTRICAL WIRING

 **WARNING:**

To avoid risk of electrical shock, personal injury, or death, disconnect all electrical power to the unit before performing any maintenance or service. The unit may have more than one electrical supply.

Label all wires prior to disconnection when servicing the unit. Wiring errors can cause improper and dangerous operation

- All electrical connections must be in compliance with all applicable local codes and ordinances, and with the current revision of the National Electric Code (ANSI/NFPA 70).
- For Canadian installations the electrical connections and grounding shall comply with the current Canadian Electrical Code (CSA C22.1 and/or local codes).

Pre-Electrical Checklist

- ✓ Verify that the voltage, frequency, and phase of the supply source match the specifications on the unit rating plate.
- ✓ Verify that the service provided by the utility is sufficient to handle the additional load imposed by this equipment. Refer to the unit wiring label for proper high and low voltage wiring.
- ✓ Verify factory wiring is in accordance with the unit wiring diagram (Figures 13-18, pages 19-24). Inspect for loose connections.

Line Voltage

- A wiring diagram is located on the inside cover of the electrical box of the outdoor unit. The installer should become familiar with the wiring diagram before making any electrical connections to the outdoor unit.
- **An electrical disconnect must be located within sight of and readily accessible to the unit.** This switch shall be capable of electrically de-energizing the outdoor unit.
- Line voltage to the unit should be supplied from a dedicated branch circuit containing the correct fuse or circuit breaker for the unit. Incoming field wiring and minimum size of electrical conductors and circuit protection must be in compliance with information listed on the outdoor unit data label. Any other wiring methods must be acceptable to authority having jurisdiction.
- The outdoor unit requires both power and control circuit electrical connections. Refer to the (Figures 13-18) for identification and location of outdoor unit field wiring interfaces. Make all electrical connections in accordance with all applicable codes and ordinances.
- Overcurrent protection must be provided at the branch circuit distribution panel and sized as shown on the unit rating label and according to applicable local codes. See the unit rating plate for minimum circuit ampacity and maximum overcurrent protection limits.
- Provide power supply for the unit in accordance with the unit wiring diagram, and the unit rating plate. Connect the line-voltage leads to the terminals on the contactor inside the control compartment.
- Use only copper wire for the line voltage power supply to this unit as listed in Table 1 (page 6). Use proper code agency listed conduit and a conduit connector for connecting the supply wires to the unit. Use of rain tight conduit is recommended.
- 208/230 Volt units are shipped from the factory wired for 230 volt operation. For 208V operation, remove the lead from the transformer terminal marked 240V and connect it to the terminal marked 208V.
- Optional equipment requiring connection to the power or control circuits must be wired in strict accordance of the NEC (ANSI/NFPA 70), applicable local codes, and the instructions provided with the equipment.

Grounding

 **WARNING:**

The unit cabinet must have an uninterrupted or unbroken electrical ground to minimize personal injury if an electrical fault should occur. Do not use gas piping as an electrical ground!

This unit must be electrically grounded in accordance with local codes or, in the absence of local codes, with the National Electrical Code (ANSI/NFPA 70) or the CSA C22.1 Electrical Code. Use the grounding lug provided in the control box for grounding the unit.

COPPER WIRE SIZE — AWG (1% Voltage Drop)				
Supply Wire Length-Feet				Supply Circuit Ampacity
200	150	100	50	
6	8	10	14	15
4	6	8	12	20
4	6	8	10	25
4	4	6	10	30
3	4	6	8	35
3	4	6	8	40
2	3	4	6	45
2	3	4	6	50
2	3	4	6	55
1	2	3	4	60

Wire Size based on N.E.C. for 60° type copper conductors.

Table 1. Copper Wire Size

Thermostat Wire Gauge	Recommended T-Stat Wire Unit to T-Stat (Length in FT)	
	2-Wire (Heating)	5-Wire (Heating/Cooling)
24	55	25
22	90	45
20	140	70
18	225	110

Table 2. Thermostat Wire Gauge

Thermostat / Low Voltage Connections

- Thermostat connections should be made in accordance with the instructions supplied with the thermostat and the indoor equipment. A typical installation with a heat pump thermostat and air handler is shown in Figure 4.
- The outdoor unit is designed to operate from a 24 VAC Class II control circuit. The control circuit wiring must comply with the current provisions of the NEC (ANSI/NFPA 70) and with applicable local codes having jurisdiction.
- The low voltage wires must be properly connected to the units low voltage terminal block. Recommended wire gauge and wire lengths for typical thermostat connections are listed in Table 2.
- The thermostat should be mounted about 5 feet above the floor on an inside wall. DO NOT install the thermostat on an outside wall or any other location where its operation may be adversely affected by radiant heat from fireplaces, sunlight, or lighting fixtures, and convective heat from warm air registers or electrical appliances. Refer to the thermostat manufacturer's instruction sheet for detailed mounting and installation information.

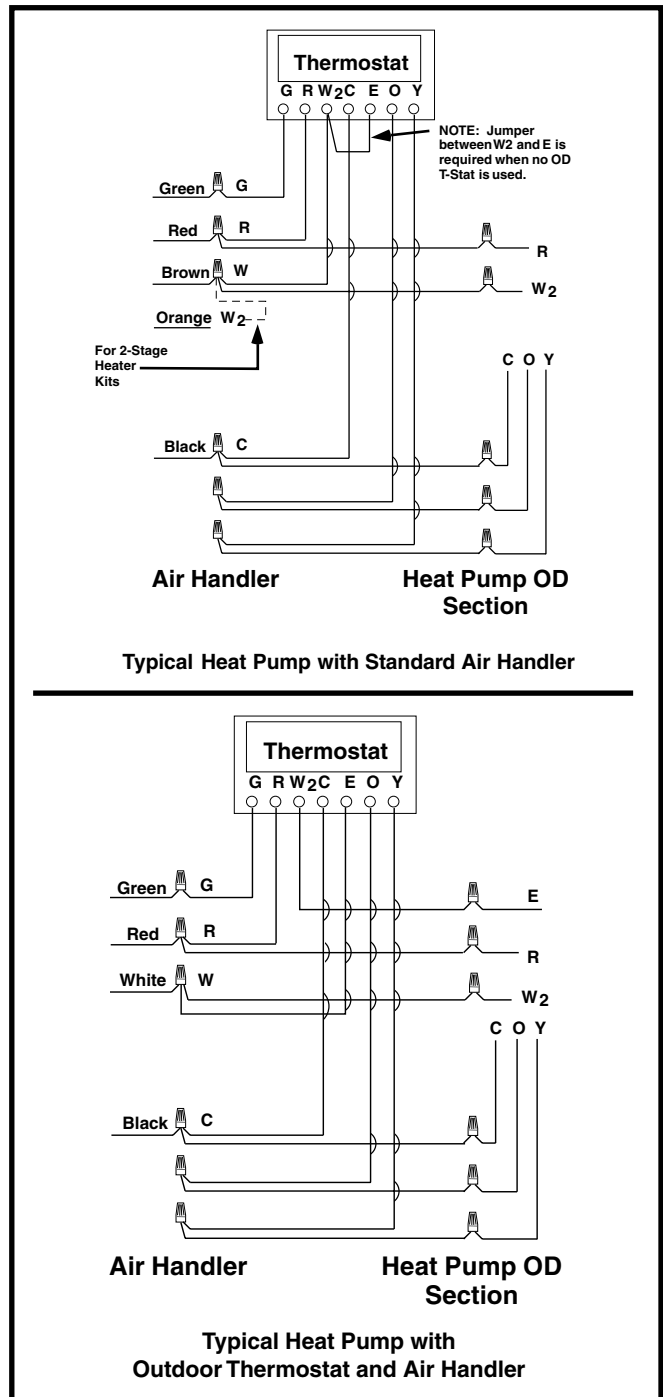

Figure 4. Typical Thermostat Connections

Blower Time Delay Relay (Select Models)

A time delay relay may be provided with the unit and must be installed in the indoor section. The relay will keep the indoor blower running an additional 40 seconds for increased cooling efficiency after the outdoor unit shuts off.

The relay has four terminals and one mounting hole.

- Connect terminal 1 to load side of blower relay.
- Connect terminal 2 to terminal **R** of T'stat.
- Connect terminal 3 to common terminal at blower relay or transformer.
- Connect terminal 4 to terminal **G** on T'stat.

CoreSense™ Diagnostics Module (Select Models Only)

The CoreSense™ Diagnostics Module (Figure 5) is a breakthrough innovation for troubleshooting heat pump and air conditioning system failures. The module installs easily in the electrical box of the outdoor unit near the compressor contactor. By using the compressor as a sensor, CoreSense Diagnostics helps the service technician more accurately troubleshoot system and compressor fault conditions.

A flashing LED indicator communicates the ALERT code and a diagnostic key is also imprinted on the side of the module to quickly direct the technician to the root cause of a problem. Alert identification codes are also listed in Table 3.

Compressor Protection

The CoreSense™ Diagnostics module utilizes proprietary algorithms to protect the compressor and system from repeated trips of system pressure controls and the compressor internal overload. The protection terminal of the module should be wired in series with the system low pressure and high pressure cutouts, as well as the compressor contactor. When the module detects a series of trips as described below, it will activate a lockout feature

that opens the normally closed protection contacts in the module, thereby cutting power to the contactor and shutting off the compressor.

Resetting Alert Codes

When the CoreSense™ Diagnostics module has detected a series of adverse conditions that have caused it to lockout the compressor, and after the issue has been resolved, it is necessary to manually reset the module in order to clear the present alert code.

The primary way of clearing the code and resetting the alert is to press the reset button located on the module.

NOTE: Pressing the reset will require a pin or a mini electronics screwdriver. This button must be pressed and held for a minimum of one second for the module to be reset. Pressing the reset button clears the immediate lock code and the seven day operating history. It will not clear the permanent module history. In the case of the three-wire module, the codes can be reset or cleared by cycling power to the module. This can be done by disengaging the Common (C) terminal. This will not clear the seven day operating history.

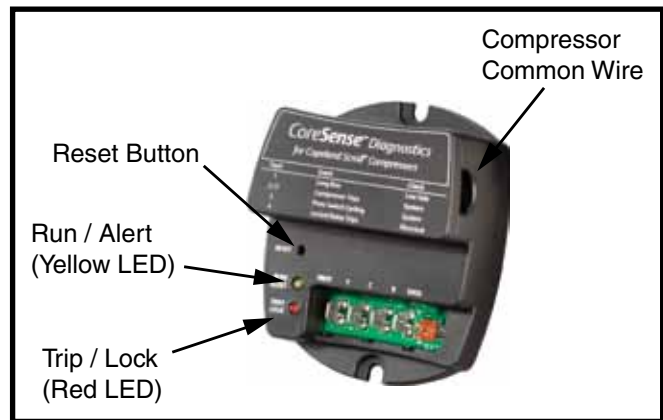

Figure 5. CoreSense™ Diagnostics Module

ALERT CODE	ALERT CONDITION	LOCK LEVEL	LOCK INDICATION
Normal Run Solid Yellow	Normal operation, no trip	N/A	N/A
Code1 Yellow Flash 1	Long run time. Compressor is on running for more than 18 hours. (Code1 is disabled in Heat Pump Mode)	N/A	N/A
Code2 Yellow Flash 2	Compressor (pressure) trip. Compressor runs for 12 sec to 15 min followed by a compressor trip condition lasting for more than 7 min.	4x consecutive	Red: Flash2 Yellow: Off
Code3 Yellow Flash 3	Pressure switch cycling. Compressor runs for 12 sec to 15 min followed by a compressor trip lasting between 35 sec to 7 min.	4x consecutive or 10x total	Red: Flash3 Yellow: Off
Code4 Yellow Flash 4	Locked rotor. Compressor trips within a compressor run time of 12 sec and does not start within 35 sec.	10x consecutive	Red: Flash4 Yellow: Off
Code5 Yellow Flash 5	Compressor (moderate run) trip. Compressor runs for 15 min to 18 hrs followed by a compressor trip lasting longer than 7 min.	4x consecutive or 10x total	Red: Flash5 Yellow: Off
Code9 Red Flash 9	The current to the PROT terminal is greater than 2A.	Current >2A for 40ms	Red: Flash9 Yellow: Off
Trip Solid Red	Demand is present, but compressor is not running.	N/A	N/A

Table 3. LED Diagnostics for CoreSense™ Diagnostics Module

START UP & ADJUSTMENTS

Pre-Start Check List

- √ Verify the unit is level and has sufficient clearances for unobstructed airflow.
- √ Verify the outdoor coil and top of the unit are free from obstructions and debris, and all equipment access/control panels are in place.
- √ Verify that the line voltage power leads are securely connected and the unit is properly grounded.
- √ Verify that the low voltage wires are securely connected to the correct leads on the low voltage terminal strip.
- √ Verify that the power supply branch circuit overcurrent protection is sized properly.
- √ Verify that the thermostat is wired correctly.

Start-Up Procedures

WARNING:

This unit is equipped with a crankcase heater. Allow 24 hours prior to continuing the start up procedures to allow for heating of the refrigerant compressor crankcase. Failure to comply may result in damage and could cause premature failure of the system. This warning should be followed at initial start up and any time the power has been removed for 12 hours or longer.

Air Circulation - Indoor Blower

1. Set the thermostat system mode on OFF and the fan mode to ON.
2. Verify the blower runs continuously. Check the air delivery at the supply registers and adjust register openings for balanced air distribution. If insufficient air is detected, examine ductwork for leaks or obstructions.
3. Set the thermostat fan mode to AUTO and verify the blower stops running.

NOTE: On 3 phase air handler models only - If blower is spinning opposite of arrow direction, shut off the main power to the unit and switch any two field wires at the disconnect. **DO NOT alter unit wiring.**

Short Cycle Protection

1. Set the thermostat system mode to COOL. Observe the temperature setting of the thermostat and gradually raise the set-point temperature until the unit de-energizes.
2. Immediately lower the set point temperature of the thermostat to its original setting and verify that the indoor blower is energized and outdoor unit remains de-energized.
3. After approximately 5 minutes, verify the outdoor unit energizes and the temperature of the discharge air is cooler than the room temperature.

System Cooling

1. Set the thermostat's system mode to COOL and the fan mode to AUTO. Gradually lower the thermostat temperature setpoint below room temperature and verify the outdoor unit and indoor blower energize.
2. Verify blower wheel is spinning in direction indicated by arrow. Feel the air being circulated by the indoor blower and verify that it is cooler than ambient temperature. Listen for any unusual noises. If unusual sounds occur, determine the source of the noise and correct as necessary.
3. Verify HI and LO refrigerant pressures.
NOTE: If refrigerant pressures are abnormal and the compressor is rotating backwards, shut off main power to the unit and switch any two field wires at the disconnect. **DO NOT alter unit wiring.**
4. Allow the system to operate for several minutes and then set the temperature selector above room temperature. Verify the fan and compressor cycle off with the thermostat. **NOTE:** The blower should also stop unless fan switch is set to the ON position.

System Heating

1. Set the thermostat's system mode to HEAT and the temperature mode to below room temperature.
2. Verify the outdoor unit and indoor fan stop running. After 5 minutes, increase the temperature on the thermostat to it's maximum setting.
3. Verify the outdoor unit and indoor blower energize. Feel the air being circulated by the indoor blower and verify that it is warmer than ambient temperature. Listen for any unusual noises. If unusual sounds occur, determine the source of the noise and correct as necessary.

Defrost Cycle Timer

The defrost cycle timer controls the time interval of the hot gas defrost after the defrost sensor closes. It is located in the lower left corner of the defrost control board on the of the control panel. Three interval settings are available: 30, 60, and 90 minutes. Time setting selection is dependent on the climate where the unit is being installed.

- Example 1: Dry climate of Southern Arizona - A 90 minute setting is recommended.
- Example 2: Moist climate of Seattle, Washington - A 30 minute setting is recommended.

To set the cycle timer, place the timing pin on the defrost control board to the desired time interval post.

NOTE: All units are shipped from the factory with the default time setting of 30 minutes. Longer settings are recommended for drier climate areas and shorter time intervals are recommended for moist climate areas. Maximum heating performance can be achieved by setting the time to 90 minutes.

Defrost Control Board

Operational Information

- Terminals **R - RC** must have 24±V present between them in order for the time delay and defrost sequences to be operational.
- Jumpering the **T2-DFT** test pins will communicate to the board that the defrost T-stat is closed (if compressor is running). The defrost thermostat tells the board whether a defrost cycle needs to be started or terminated.

NOTE: The defrost T-stat is closed at 32° F or below and is open at 68° F or above, but it's state is unknown if the temperature is between 32° F & 68° F.

- With the DFT closed, the unit will run for 30/60/90 minutes in heat mode and then defrost the outdoor coil. The defrost will turn off the outdoor fan, turn on the compressor and raise the coil temperature to 68° F. This will open the DFT and terminate the defrost. If the DFT does not open the defrost will end after 10 minutes.
- To over-ride the defrost board and initiate a faster defrost test in 5, 10 or 15 seconds as determined by the 30, 60 or 90 minute defrost pin settings (factory setting is 30 minutes), jumper the **TEST** terminal to the **C** (common) terminal while the compressor is in heat mode.
 - This will bypass the compressor off delay when the unit goes into defrost test and if left in defrost test, the delay will be bypassed when the test is terminated by the processor. **NOTE:** If the jumper is removed before the test is over, the processor will perform the remainder of a normal defrost. See bullet 2 above.
- To switch from no-delay to delay, remove the pin from the **no - delay** pin location and shift it to the **delay** pin location. The delay/no-delay pin concerns compressor operation during defrosts. The default setting is delay.
 - Reciprocating compressors should only use this setting in conjunction with an approved hard start kit.
 - Scroll compressors that have noise issues while going into or coming out of defrost should use this 30 second delay to reduce the defrost noise.
 - Manually initiating a defrost will cause the compressor to run continually when entering defrost.

Normal defrost operation

To test normal defrost operation when the temperature is above 35° F, jumper **R** to **DFT** on the board and allow the unit to run for 30 minutes. Defrost will continue until the **R** to **DFT** jumper is removed or for 10 minutes. Remove the jumper.

The 5 minute time delay feature can be shortened 1 time to 1 second by jumping the **Test** to **C** terminal. Remove the jumper and repeat as desired.

NOTE: If jumper is left on the **Test** to **common** pins permanently, the defrost cycle will become inoperable.

Defrost Test Procedure

1. Jumper **T2** to **DFT** at the test terminals.
2. With unit running in heat mode, short the **TEST** terminal to the common terminal near it. This will speed up the board and cause it to enter defrost mode in 5/10/15 seconds depending on the defrost time selection. Compressor delay will not function during speed-up.
3. This test will end in 5 seconds if the **TEST**-common short is not removed.
4. Remove both the short and the **T2** to **DFT** jumper to terminate the defrost cycle. The 30 second compressor delay should operate normally.
5. Test is complete, reset thermostat to home owner preference.

Anti Short Cycle Timer Test

The 5 minute time delay feature can be bypassed or shortened to 1 second by jumping the **Test** to **C** terminal.

NOTE: If jumper is left on the **Test** to **common** pins permanently, the defrost cycle will become inoperable.

HEAT PUMP MAINTENANCE

WARNING:

To prevent electrical shock, personal injury, or death, disconnect all electrical power to the unit before performing any maintenance or service. The unit may have more than one electrical supply.

Proper maintenance is important to achieve optimum performance from the heat pump. The ability to properly perform maintenance on this equipment requires certain mechanical skills and tools. If you do not possess these skills, contact your dealer for maintenance. Consult your local dealer about the availability of maintenance contracts. Routine maintenance should include the following:

- Inspect and clean or replace air filters at the beginning of each heating and cooling season, or more frequently if required.
- Inspect the outdoor coil at the beginning of each cooling season. Remove any debris. Clean the outdoor coil and louvers as necessary using a mild detergent and water. Rinse thoroughly with water.
- Inspect the electrical connections for tightness at the beginning of each heating and cooling season. Service as necessary.

CAUTION:

The unit should never be operated without a filter in the return air system. Replace disposable filters with the same type and size.

- Do not add additional oil to motors unequipped with oil tubes. The compressor is hermetically sealed at the factory and does not require lubrication.

REFRIGERANT CHARGING

WARNING:

T4BE Split System Heat Pumps are shipped charged with R410A refrigerant and ready for installation. If repairs make it necessary for evacuation and charging, it should only be attempted by qualified trained personnel thoroughly familiar with this equipment. Under no circumstances should the owner attempt to install and/or service this equipment. Failure to comply with this warning could result in property damage, personal injury, or death.

After refrigerant line connections are completed, it is required that you leak check and evacuate the indoor section and all line connections (using proper methods) before finalizing the full system refrigerant charge.

- To achieve rated capacity and efficiency, the compressor must be exposed to refrigerant for at least 24 hours prior to running and then the compressor must be run for a minimum of 12 hours.
- Cooling mode charging charts are applicable only to matched assemblies and listed airflows for the indoor coil. T4BE outdoor units with non-AHRI listed indoor coils are not recommended and deviations from rated airflows or non-listed combinations may require modification to the expansion device and refrigerant charging procedures for proper and efficient system operation. Refer to Figures 6 - 12 (pages 11 - 14) and Tables 4 - 9 (pages 16 & 17) for correct system charging.
- The refrigerant charge can be checked and adjusted through the service ports provided external to the outdoor unit. Use only gage line sets which have a "Schrader" depression device present to actuate the valve. A common suction port for heating mode charging is included and located on the compressor access panel above the outdoor unit service valves.
- Heat Mode Verification Tables (Tables 3 - 9, pages 16-18) are provided for quick reference when the unit is in heating mode and for the inspection of the liquid line pressures and temperatures.
- A high-pressure switch is factory-installed and located

in the compressor discharge line internal to the outdoor unit. The switch is designed to de-energize the system when very high pressures occur during abnormal conditions. Under normal conditions, the switch is closed. If the discharge pressure rises above 575 psig, then the switch will open and de-energize the outdoor unit. The switch will close again once the liquid pressure decreases to 460 psig. Please note that the switch interrupts the thermostat inputs to the unit. When the switch opens and then closes, there will be a 5 minute short cycling delay before the outdoor unit will energize.

- A low-pressure switch is factory-installed in select models only. If provided, this located in the suction line internal to the outdoor unit. The switch is designed to protect the compressor from a loss of charge. Under normal conditions, the switch is closed. If the suction pressure falls below 5 psig, then the switch will open and de-energize the outdoor unit. The switch will close again once the suction pressure increases above 20 psig. Please note that the switch interrupts the thermostat inputs to the unit. When the switch opens and then closes, there will be a 5 minute short cycling delay before the outdoor unit will energize.

Charging the Unit in AC Mode with Outdoor Temperatures Above 55° F

(for optimized sub-cooling of 10° F to 12° F)

1. With the system operating at steady-state, measure the liquid refrigerant pressure (in psig) at the outdoor unit service valve.
2. Measure the liquid refrigerant temperature (in Fahrenheit) at the service valve.
3. Determine the required liquid refrigerant pressure from Figures 6 - 12 (pages 11 - 14).
 - If the pressure measured in Step 1 is greater than the required liquid refrigerant pressure determined in Step 3, then there is too much charge in the system. Remove refrigerant and repeat Steps 1 through 3 until the system is correctly charged.
 - If the pressure measured in Step 1 is less than the required liquid refrigerant pressure determined in Step 3, there is too little charge in the system. Add refrigerant and repeat Steps 1 through 3 until the system is correctly charged.

T4BE REFRIGERANT CHARGING CHARTS - COOLING ONLY

Application notes for using cooling charging charts

- This equipment's cooling system contains refrigerant under high pressure. Always use safe and environmentally sound methods when handling refrigerant handling or servicing the unit. Review the factory literature and safety warnings prior to servicing.
- When repairing system leaks, always use a nitrogen (inert) gas to protect the refrigerant system and pressure check the repair before re-charging. Always replace the filter-dryers when performing any repair to the refrigeration system with one capable of acid removal. After completing the repairs, evacuate the system to 350 - 500 microns and weigh in the refrigerant to the amount specified on the unit rating label.
- Charging charts are valid for a variety of indoor, return air conditions and are most influenced by the outdoor ambient temperature, outdoor fan operation and the unit operating voltage. Before using these charts, make sure the unit is in a stable operating mode. As shown in the charging charts (Figures 6 - 12, pages 11 - 14), the ideal system sub-cooling can vary over the range of operation. Reference the charts to determine the ideal amount of sub-cooling for a given liquid pressure. Units charged to other values will not perform at the rated unit efficiency (EER) or rated Coefficient of Performance (COP) in heating mode.
- To inspect a systems operation using quality instruments, match the measured liquid temperature to the units chart. The measured liquid pressure reading should be within 3% of the charts value for most installations.
- For systems that are operating with more than a 5% deviation, inspect the unit for the proper voltage and phase balance and the refrigeration system for leaks.
- Units that are operating at less then 95% of the nominal voltage or with a 2% phase imbalance may see a more significant deviation than the amount stated above.
- **DO NOT** use the charts in systems that have a fan cycling under low-ambient control. Refer to the low-ambient kit instructions for more information. (If applicable).

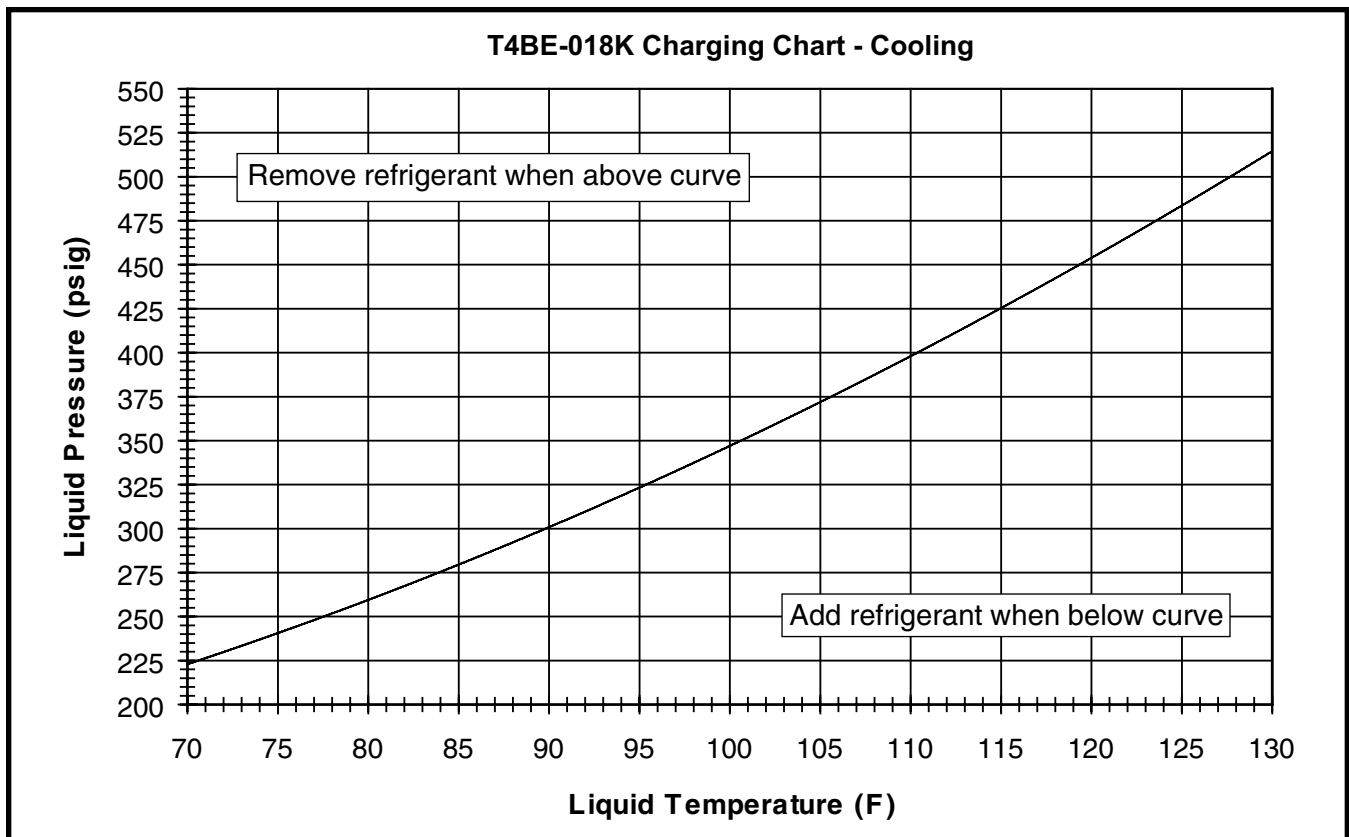

Figure 6. Charging Chart for T4BE-018 Series (1.5 Ton Units) - TXV Matches

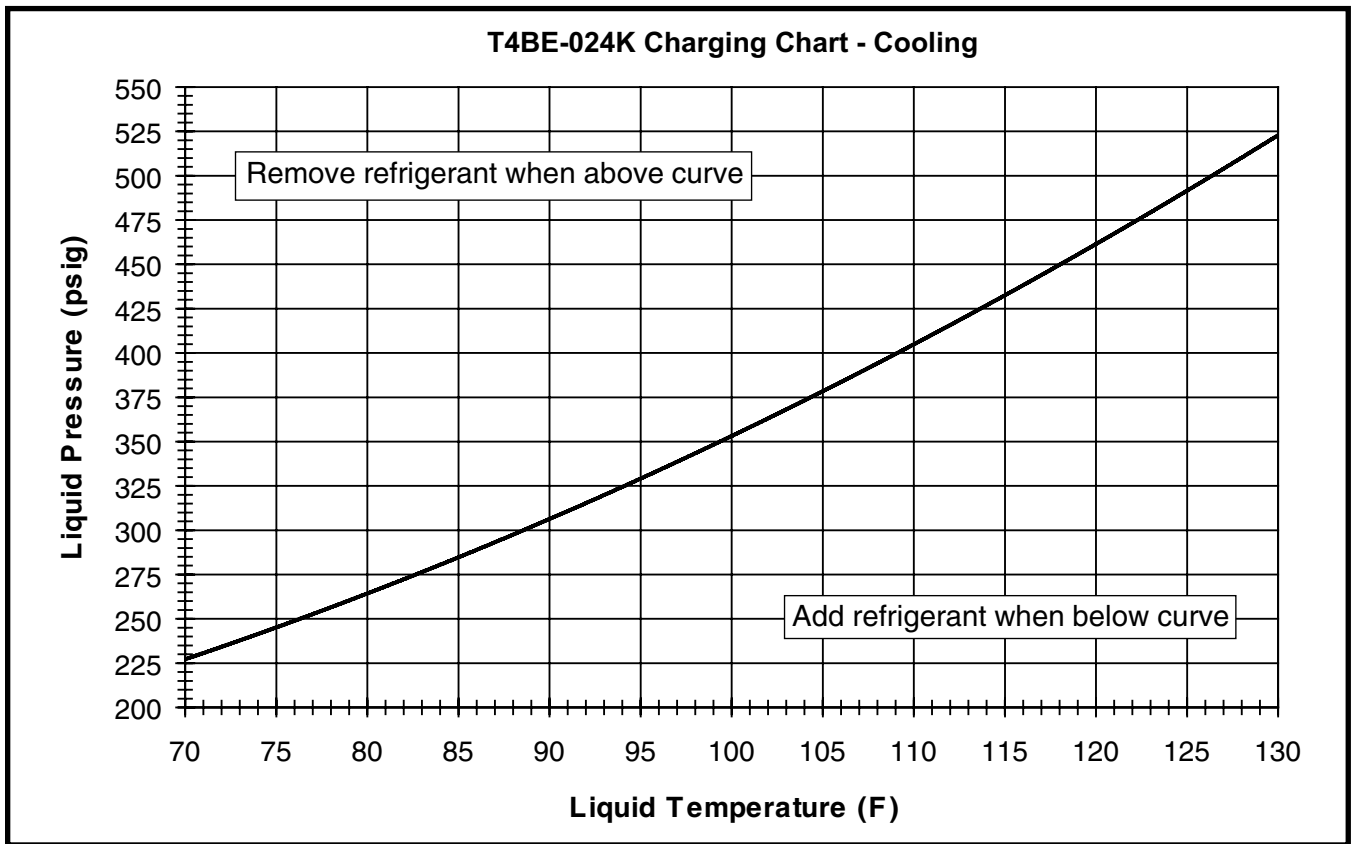

Figure 7. Charging Chart for T4BE-024 Series (2 Ton Units) - TXV Matches

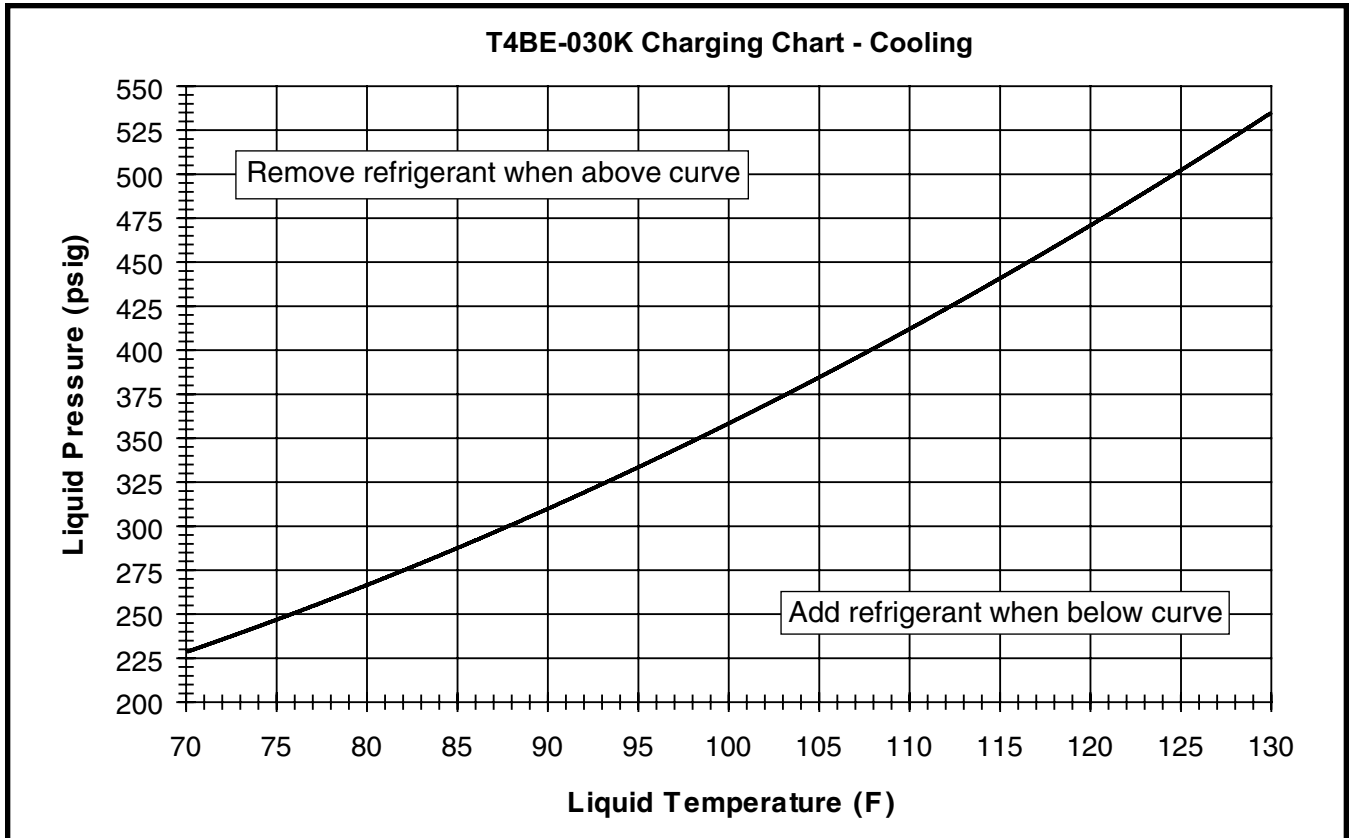

Figure 8. Charging Chart for T4BE-030 Series (2.5 Ton Units) - TXV Matches

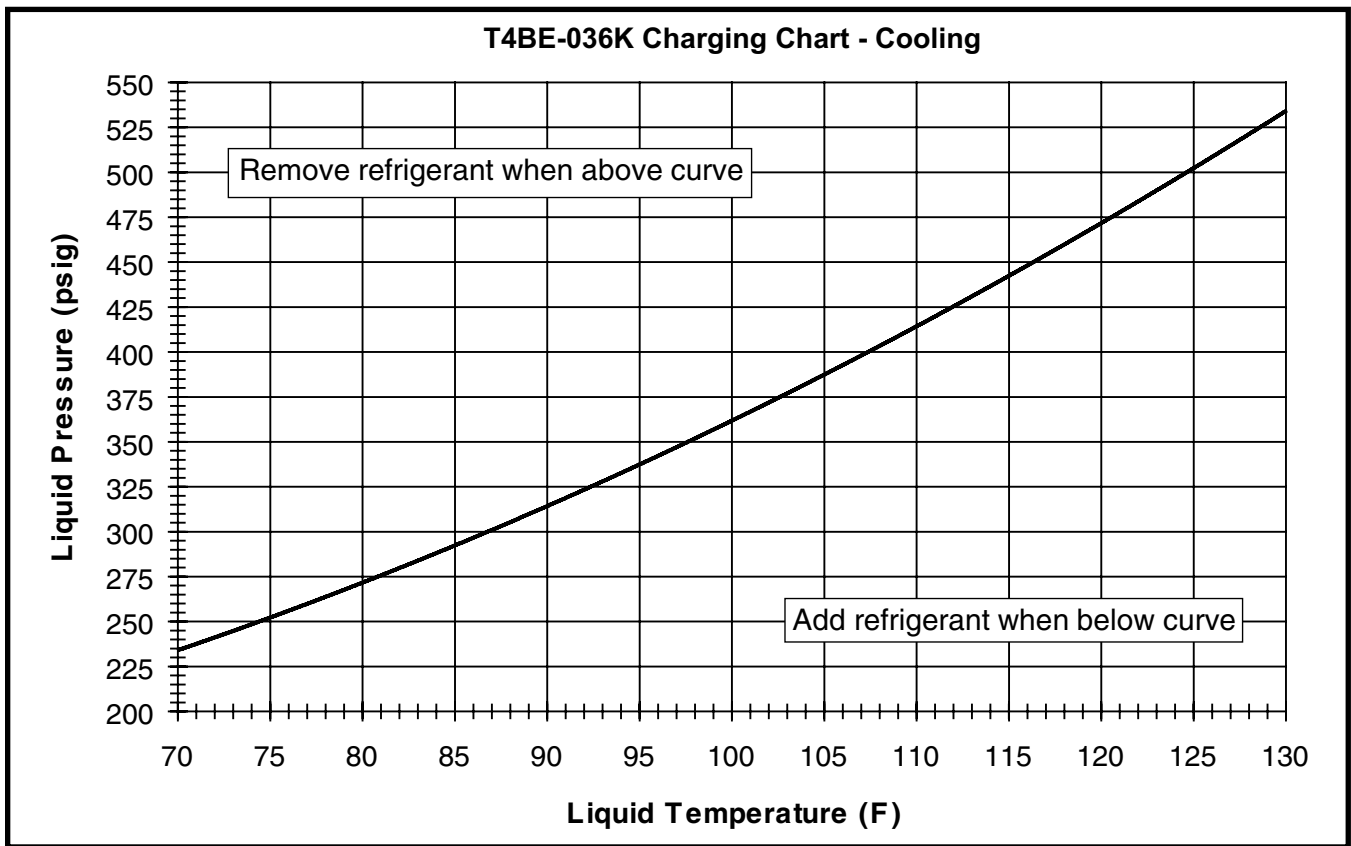

Figure 9. Charging Chart for T4BE-036 Series (3 Ton Units) - TXV Matches

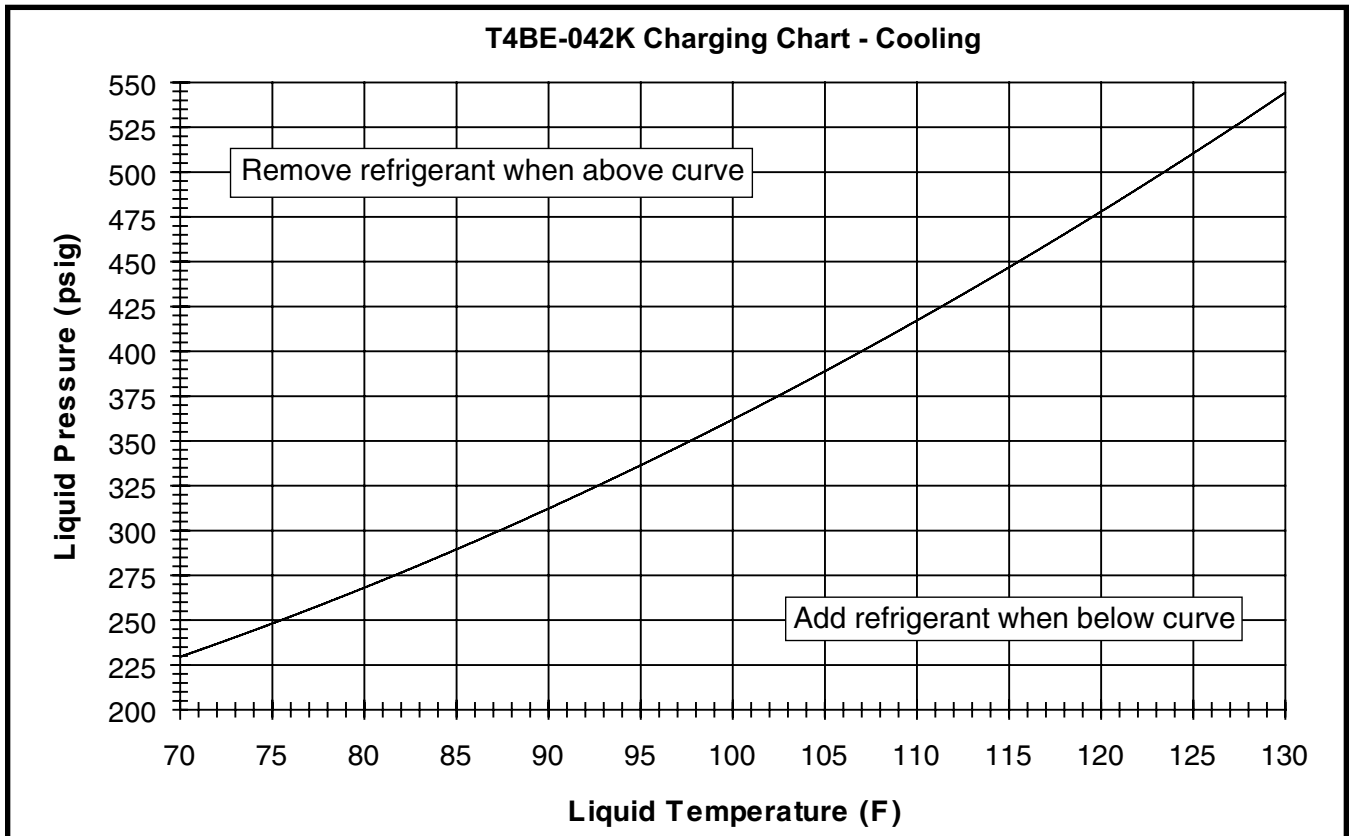

Figure 10. Charging Chart for T4BE-042 Series (3.5 Ton Units) - TXV Matches

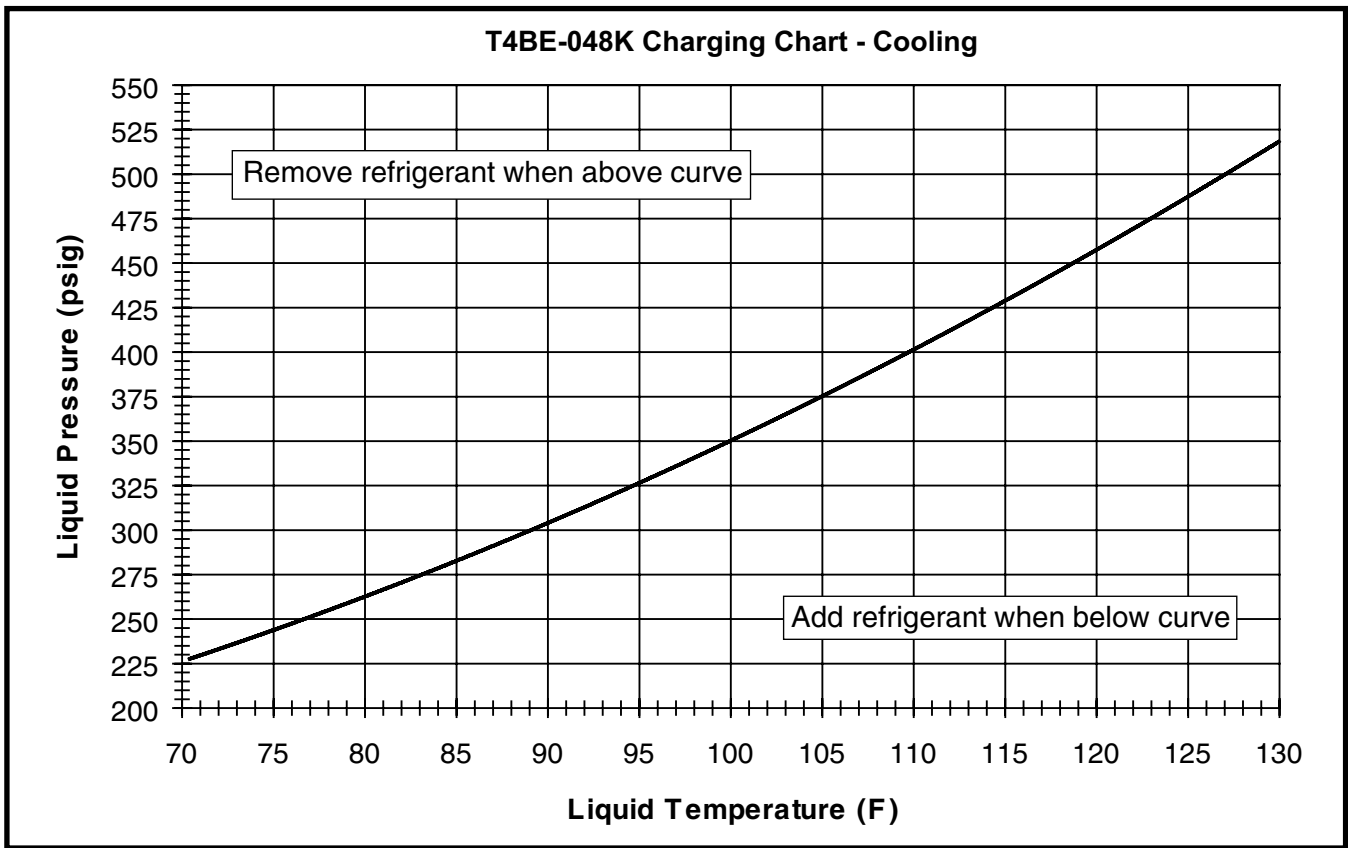

Figure 11. Charging Chart for T4BE-048 Series (4 Ton Units) - TXV Matches

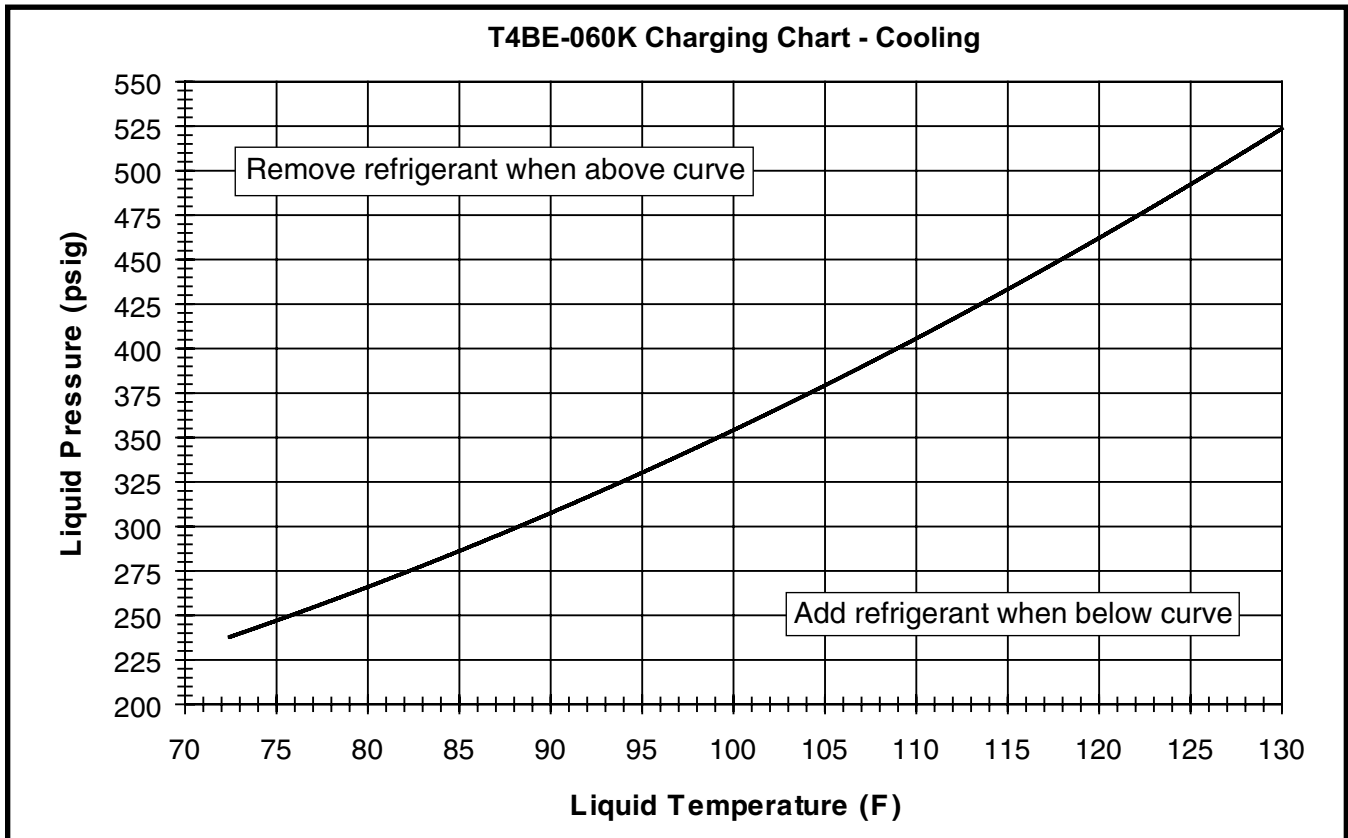



Figure 12. Charging Chart for T4BE-060 Series (5 Ton Units) - TXV Matches

T4BE HEAT MODE VERIFICATION CHARTS - HEATING ONLY

Application Notes on the use of Heating-mode charge verification charts:

LEGEND

-  Shaded boxes indicate flooded conditions.
-  Rated design values. Suction pressure will vary from design value if outdoor air flow, entering dry bulb, or entering wet bulb temperatures vary.

- **Read all notes and warnings for the Cooling-mode charging charts prior to using these Heating-mode charge verification charts. Always use safe and environmentally sound methods when handling refrigerant handling or servicing the unit. Review the factory literature and safety warnings prior to servicing.**
- When repairing system leaks, always use a nitrogen (inert) gas to protect the refrigerant system and pressure check the repair before re-charging. Always replace the filter-dryers when performing any repair to the refrigeration system with one capable of acid removal. After completing the repairs, evacuate the system to 350 - 500 microns and weigh in the refrigerant to the amount specified on the unit rating label.
- Before using Tables 4 - 9 (pages 16 & 17), determine the outdoor ambient temperature and the return air temperature to the unit. Locate the appropriate location on the units verification chart based on those measurements to determine the ideal discharge pressure and temperature. Verify the outdoor fan and compressor are running and the outdoor coil is free from frost accumulation. Also verify the system is not operating in defrost mode before inspecting the system.
- Always use quality instruments that are in good working order to measure the actual operating point of the refrigeration system. The discharge temperature should be within 2 degrees of the ideal value and the pressure should be within 2%.
- The most reliable way of verifying the system is at the correct charge is to evacuate the system and weigh in the charge to the amount shown on the rating label. However, if an inspection with these verification charts does not line up with the values shown and the ambient temperature is above 50° F, then a more accurate way to inspect the system for proper charge is with the cooling mode charging charts. Switch the unit into cooling mode and allow it to operate and stabilize for a few minutes then inspect the unit operation with the cooling mode charts and procedures.

NOTES:

1. All pressures are listed psig and all temperatures in °F
2. Discharge temperatures greater than charted values indicate an undercharged system.

Before changing the unit charge, always inspect the following items first:

1. Inspect the liquid line temperature on the inlet and outlet of the filter dryers. If it is the factory dryer and in good condition there should be no temperature difference. If the temperature difference is larger than 5°, replace the filter dryer with one that is bi-directional and has acid removal capability. Refer to the unit RPL for the recommended part number and size.
2. Inspect the units input voltage. Units operating at less than 95% of the nominal voltage may deviate more from the chart than previously stated.
3. Inspect the input voltage for a phase imbalance. Units with greater than a 2% disparity will not operate at the rated performance.
4. Verify that the unit filters are installed and are clean. The pressure drop across the filters should not exceed 0.08 in-W.C.
5. Inspect the indoor coil, indoor blower and blower motor for cleanliness, clogging, and proper operation.
6. Inspect the system for leaks. If any leaks are detected, repair them immediately. Re-inspect the return air and ambient temperatures and verify that the correct system point on the verification chart was selected.

DO NOT use the charts in systems that have the fan cycling under a low-ambient control. Low-ambient controls are for cooling operation. In heating mode, the low ambient control should be disabled. Unless the unit is in defrost mode, the outdoor fan should always operate in conjunction with the compressor.

IMPORTANT NOTE: If the unit is equipped with a liquid valve with an outdoor restrictor (Figure 2 page 5), then it is not possible to measure the liquid pressure. To approximate the liquid pressure, subtract 7 psig from the discharge pressure.

OUTDOOR TEMPERATURE (DEG. F)																				
0			10			20			30			40			50			60		
Suc. Press.	Disch. Press.	Disch. Temp.	Suc. Press.	Disch. Press.	Disch. Temp.	Suc. Press.	Disch. Press.	Disch. Temp.	Suc. Press.	Disch. Press.	Disch. Temp.	Suc. Press.	Disch. Press.	Disch. Temp.	Suc. Press.	Disch. Press.	Disch. Temp.	Suc. Press.	Disch. Press.	Disch. Temp.
32	207	104	50	233	115	67	260	126	84	286	137	100	303	139	115	332	131	130	361	123
33	214	102	51	239	113	68	264	124	85	290	135	101	310	136	116	339	126	131	368	117
34	221	100	52	245	111	69	269	122	86	294	133	102	317	133	117	346	122	132	375	111
35	228	98	53	251	109	70	274	120	87	297	131	103	324	130	118	353	117	133	382	104
36	235	96	54	257	107	71	279	118	88	301	129	104	331	127	119	360	113	134	389	98
37	242	94	55	263	105	72	284	116	89	305	127	105	338	125	120	367	108	135	396	92
38	249	92	56	268	103	73	288	114	90	308	125	106	345	122	121	374	104	136	403	86

Table 4. Charging Table for T4BE-018 Series (1.5 Ton Units)

OUTDOOR TEMPERATURE (DEG. F)																				
0			10			20			30			40			50			60		
Suc. Press.	Disch. Press.	Disch. Temp.	Suc. Press.	Disch. Press.	Disch. Temp.	Suc. Press.	Disch. Press.	Disch. Temp.	Suc. Press.	Disch. Press.	Disch. Temp.	Suc. Press.	Disch. Press.	Disch. Temp.	Suc. Press.	Disch. Press.	Disch. Temp.	Suc. Press.	Disch. Press.	Disch. Temp.
30	201	99	47	230	107	64	258	115	81	287	122	97	298	130	112	315	137	127	332	145
31	208	97	48	235	105	65	263	113	82	291	120	98	305	127	113	322	133	128	339	139
32	215	95	49	241	103	66	268	111	83	295	118	99	312	124	114	329	128	129	346	132
33	222	93	50	247	101	67	273	109	84	298	116	100	319	121	115	336	124	130	353	126
34	229	91	51	253	99	68	277	107	85	302	114	101	326	119	116	343	119	131	360	120
35	236	89	52	259	97	69	282	105	86	306	112	102	333	116	117	350	115	132	367	114
36	243	87	53	265	95	70	287	103	87	309	110	103	340	113	118	357	110	133	374	108

Table 5. Charging Table for T4BE-024 Series (2 Ton Units)

OUTDOOR TEMPERATURE (DEG. F)																				
0			10			20			30			40			50			60		
Suc. Press.	Disch. Press.	Disch. Temp.	Suc. Press.	Disch. Press.	Disch. Temp.	Suc. Press.	Disch. Press.	Disch. Temp.	Suc. Press.	Disch. Press.	Disch. Temp.	Suc. Press.	Disch. Press.	Disch. Temp.	Suc. Press.	Disch. Press.	Disch. Temp.	Suc. Press.	Disch. Press.	Disch. Temp.
33	230	122	48	258	133	63	286	145	78	314	156	91	334	170	102	369	186	113	403	202
34	237	120	49	264	131	64	291	143	79	318	154	92	341	167	103	376	181	114	410	195
35	244	118	50	270	129	65	296	141	80	322	152	93	348	164	104	383	177	115	417	189
36	251	116	51	276	127	66	300	139	81	325	150	94	355	161	105	390	172	116	424	183
37	258	114	52	282	125	67	305	137	82	329	148	95	362	158	106	397	168	117	431	177
38	265	112	53	287	123	68	310	135	83	333	146	96	369	156	107	404	163	118	438	171
39	272	110	54	293	121	69	315	133	84	336	144	97	376	153	108	411	159	119	445	165

Table 6. Charging Table for T4BE-030 Series (2.5 Ton Units)

OUTDOOR TEMPERATURE (DEG. F)																				
0			10			20			30			40			50			60		
Suc. Press.	Disch. Press.	Disch. Temp.	Suc. Press.	Disch. Press.	Disch. Temp.	Suc. Press.	Disch. Press.	Disch. Temp.	Suc. Press.	Disch. Press.	Disch. Temp.	Suc. Press.	Disch. Press.	Disch. Temp.	Suc. Press.	Disch. Press.	Disch. Temp.	Suc. Press.	Disch. Press.	Disch. Temp.
30	202	111	46	233	114	62	263	117	78	294	120	94	315	133	109	350	155	125	385	178
31	209	109	47	238	112	63	268	115	79	297	118	95	322	130	110	357	151	126	392	172
32	216	107	48	244	110	64	273	113	80	301	116	96	329	128	111	364	146	127	399	165
33	223	105	49	250	108	65	277	111	81	305	114	97	336	125	112	371	142	128	406	159
34	230	103	50	256	106	66	282	109	82	308	112	98	343	122	113	378	137	129	413	153
35	237	101	51	262	104	67	287	107	83	312	110	99	350	119	114	385	133	130	420	147
36	244	99	52	268	102	68	292	105	84	316	108	100	357	116	115	392	128	131	427	141

Table 7. Charging Table for T4BE-036 Series (3 Ton Units)

OUTDOOR TEMPERATURE (DEG. F)																											
Suc. Press.	0			Suc. Press.	10			Suc. Press.	20			Suc. Press.	30			Suc. Press.	40			Suc. Press.	50			Suc. Press.	60		
	Disch. Press.	Disch. Temp.	Disch. Temp.		Disch. Press.	Disch. Press.	Disch. Temp.		Disch. Press.	Disch. Press.	Disch. Temp.		Disch. Press.	Disch. Press.	Disch. Temp.		Disch. Press.	Disch. Press.	Disch. Temp.		Disch. Press.	Disch. Press.	Disch. Temp.		Disch. Press.	Disch. Press.	Disch. Temp.
31	226	124	46	249	132	62	272	140	77	295	148	93	316	157	109	359	169	125	402	180							
32	233	122	47	255	130	63	277	138	78	299	146	94	323	154	110	366	164	126	409	174							
33	240	120	48	261	128	64	282	136	79	302	144	95	330	152	111	373	160	127	416	168							
34	247	118	49	267	126	65	286	134	80	306	142	96	337	149	112	380	155	128	423	162							
35	254	116	50	273	124	66	291	132	81	310	140	97	344	146	113	387	151	129	430	156							
36	261	114	51	278	122	67	296	130	82	313	138	98	351	143	114	394	146	130	437	150							
37	268	112	52	284	120	68	301	128	83	317	136	99	358	140	115	401	142	131	444	143							

Table 8. Charging Table for T4BE-042 Series (3.5 Ton Units)

OUTDOOR TEMPERATURE (DEG. F)																											
Suc. Press.	0			Suc. Press.	10			Suc. Press.	20			Suc. Press.	30			Suc. Press.	40			Suc. Press.	50			Suc. Press.	60		
	Disch. Press.	Disch. Temp.	Disch. Temp.		Disch. Press.	Disch. Press.	Disch. Temp.		Disch. Press.	Disch. Press.	Disch. Temp.		Disch. Press.	Disch. Press.	Disch. Temp.		Disch. Press.	Disch. Press.	Disch. Temp.		Disch. Press.	Disch. Press.	Disch. Temp.		Disch. Press.	Disch. Press.	Disch. Temp.
29	220	115	45	241	119	61	262	123	78	284	127	93	301	138	108	337	156	122	373	174							
30	227	113	46	247	117	62	267	121	79	287	125	94	308	135	109	344	152	123	380	168							
31	234	111	47	253	115	63	272	119	80	291	123	95	315	133	110	351	147	124	387	161							
32	241	109	48	259	113	64	277	117	81	295	121	96	322	130	111	358	143	125	394	155							
33	248	107	49	265	111	65	281	115	82	298	119	97	329	127	112	365	138	126	401	149							
34	255	105	50	271	109	66	286	113	83	302	117	98	336	124	113	372	134	127	408	143							
35	262	103	51	276	107	67	291	111	84	306	115	99	343	121	114	379	129	128	415	137							

Table 9. Charging Table for T4BE-048 Series (4 Ton Units)

OUTDOOR TEMPERATURE (DEG. F)																											
Suc. Press.	0			Suc. Press.	10			Suc. Press.	20			Suc. Press.	30			Suc. Press.	40			Suc. Press.	50			Suc. Press.	60		
	Disch. Press.	Disch. Temp.	Disch. Temp.		Disch. Press.	Disch. Press.	Disch. Temp.		Disch. Press.	Disch. Press.	Disch. Temp.		Disch. Press.	Disch. Press.	Disch. Temp.		Disch. Press.	Disch. Press.	Disch. Temp.		Disch. Press.	Disch. Press.	Disch. Temp.		Disch. Press.	Disch. Press.	Disch. Temp.
30	247	134	43	264	136	55	282	137	67	299	139	82	323	149	100	378	166	118	433	183							
31	254	132	44	270	134	56	286	135	68	303	137	83	330	146	101	385	161	119	440	177							
32	261	130	45	276	132	57	291	133	69	306	135	84	337	143	102	392	157	120	447	171							
33	268	128	46	282	130	58	296	131	70	310	133	85	344	140	103	399	152	121	454	165							
34	275	126	47	288	128	59	301	129	71	314	131	86	351	137	104	406	148	122	461	158							
35	282	124	48	293	126	60	305	127	72	317	129	87	358	134	105	413	143	123	468	152							
36	289	122	49	299	124	61	310	125	73	321	127	88	365	132	106	420	139	124	475	146							

Table 10. Charging Table for T4BE-060 Series (5 Ton Units)

WIRING DIAGRAM

Split System Heat Pump (Outdoor Section)

NOTES:

1. Disconnect all power before servicing.
2. For supply connections use copper conductors only.
3. Not suitable on systems that exceed 150 volts to ground.
4. For replacement wires use conductors suitable for 105°C.
5. For ampacities and overcurrent protection, see unit rating plate.
6. Connect to 24 vac/40va/class 2 circuit. See furnace/air handler installation instructions for control circuit and optional relay/transformer kits.

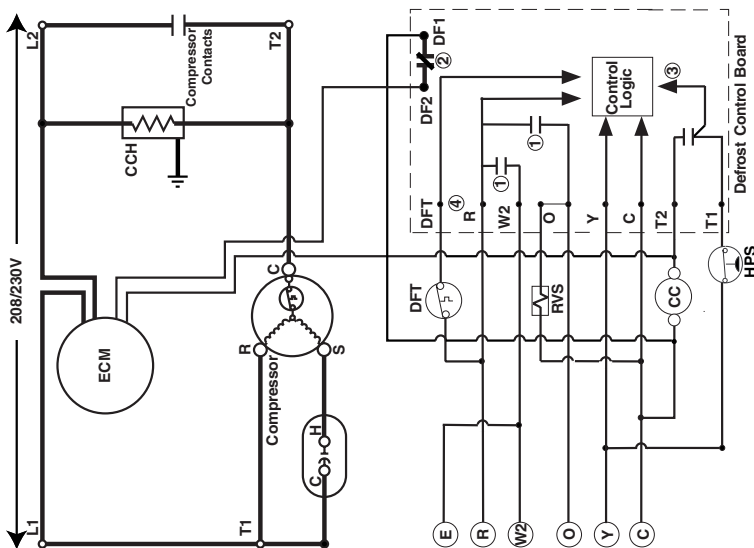

Defrost Board Operation:

1. Closing during defrost. Rating: 1 Amp Max
2. Opens during defrost. Rating: 2HP at 230 Vac Max.
3. Closed when "y" is on. Open when "y" is off. Provides "off" delay time of 5 min. when "y" opens.
4. With DFT closed and "y" closed, compressor run time is accumulated. Opening of DFT during defrost or interval period resets the interval to 0.

Single Phase

1. Couper le courant avant de faire leretien.
2. Employez uniquement des conducteurs en cuivre.
3. Ne convient pas aux installations de plus de 150 volt a la terre.

LEGEND:

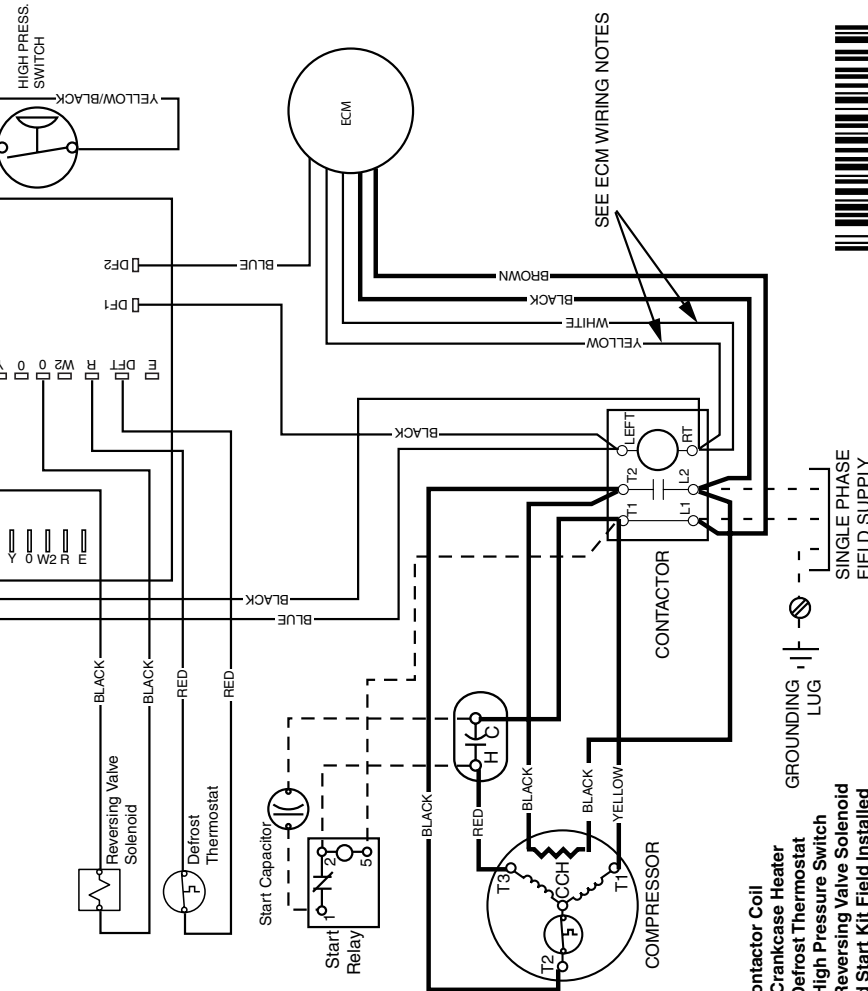

ECM WIRING NOTES:
 1) FOR 925 RPM ATTACH WHITE TO RIGHT CONTACTOR, FOR SKUS 919660, 919661, 919662, 919664
 2) FOR 960 RPM ATTACH YELLOW TO RIGHT CONTACTOR, (FOR SKU 919663)
 3) FOR 1100 RPM ATTACH WHITE AND YELLOW TO RIGHT CONTACTOR.

- CC - Contactor Coil
- CCH - Crankcase Heater
- DFT - Defrost Thermostat
- HPS - High Pressure Switch
- RVS - Reversing Valve Solenoid
- * - Hard Start Kit Field Installed



710658A (Replaces 7106580)

Figure 13. Wiring Diagram for CSH4BE, DT4BE, ET4BE, JT4BE, & MSH4BE Series (1.5 to 3.5 Ton Models)

WIRING DIAGRAM

Split System Heat Pump (Outdoor Section)

- NOTES:**
1. Disconnect all power before servicing.
 2. For supply connections use copper conductors only.
 3. Not suitable on systems that exceed 150 volts to ground.
 4. For replacement wires use conductors suitable for 105°C.
 5. For ampacities and overcurrent protection, see unit rating plate.
 6. Connect to 24 vac/40va/class 2 circuit. See urance/air handler installation instructions for control circuit and optional relay/transformer kits.

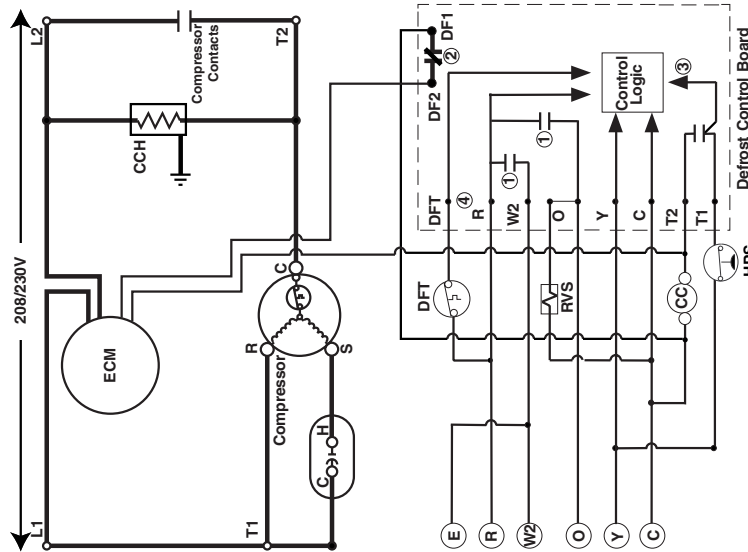

Defrost Board Operation:

1. Closing during defrost. Rating: 1 Amp Max.
2. Opens during defrost. Rating: 2HP at 230 Vac Max.
3. Closed when "y" is on. Open when "y" is off.
4. Provides "off" delay time of 5 min. when "y" opens. With DFT closed and "y" closed, compressor run time is accumulated. Opening of DFT during defrost or interval period resets the interval to 0.

Single Phase

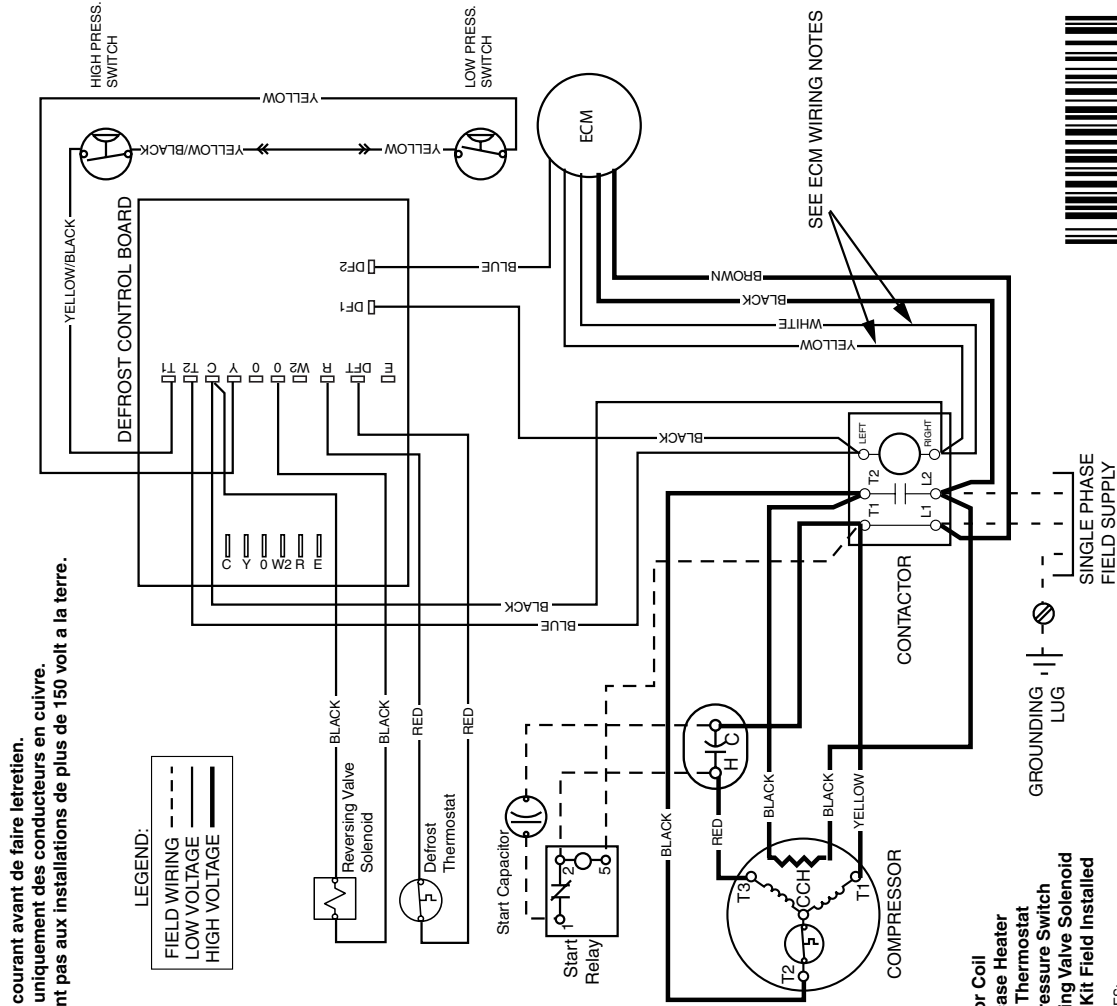

- ECM WIRING NOTES:**
- 1) FOR 825 RPM ATTACH WHITE TO RIGHT CONTACTOR, (FOR SKUS 919660, 919661, 919662, 919664)
 - 2) FOR 960 RPM ATTACH YELLOW TO RIGHT CONTACTOR, (FOR SKU 919663)
 - 3) FOR 1100 RPM ATTACH WHITE AND YELLOW TO RIGHT CONTACTOR.



710659A (Replaces 7106590)

Figure 14. Wiring Diagram for FT4BE Series (1.5 to 3.5 Ton Models)

WIRING DIAGRAM

Split System Heat Pump (Outdoor Section)

Single Phase

- NOTES:**
1. Disconnect all power before servicing.
 2. For supply connections use copper conductors only.
 3. Not suitable on systems that exceed 150 volts to ground.
 4. For replacement wires use conductors suitable for 105°C.
 5. For ampacities and overcurrent protection, see unit rating plate.
 6. Connect to 24 vac/40va/class 2 circuit. See Furnace/air handler installation instructions for control circuit and optional relay/transformer kits.

1. Couper le courant avant de faire le trefreien.
2. Employez uniquement des conducteurs en cuivre.
3. Ne convient pas aux installations de plus de 150 volt a la terre.

CoreSense Status LED	Status LED Description	Lockout Level	Lockout Indication
Normal Run; Solid Yellow	Normal Operation, no trip	N/A	N/A
Code 1; Yellow Flash 1	Long Run Time. Compressor running extremely/long run cycle, (disabled in HP mode.)	N/A	N/A
Code 2; Yellow Flash 2	Compressor Pressure Trip. Disch. or suct. pressure out of limits or compressor overloaded.	4 cons, 10x total	Red: Flash 2
Code 3; Yellow Flash 3	Short Cycling. Compressor is running only briefly.	4 cons, 10x total	Red: Flash 3
Code 4; Yellow Flash 4	Locked Rotor.	10 consecutive	Red: Flash 4
Code 5; Yellow Flash 5	Compressor Moderate Run. Compressor runs > 15min, then trips > 7min.	4 cons, 10x total	Red: Flash 5
Code 9; Red Flash 19	Over Current Protection. PROT terminal has >2A input for more than 40ms	1 Occurrence	Red: Flash 9
Trip: Solid Red	Demand but compressor is not running	N/A	N/A

Instructions for control circuit and optional relay/transformer kit.

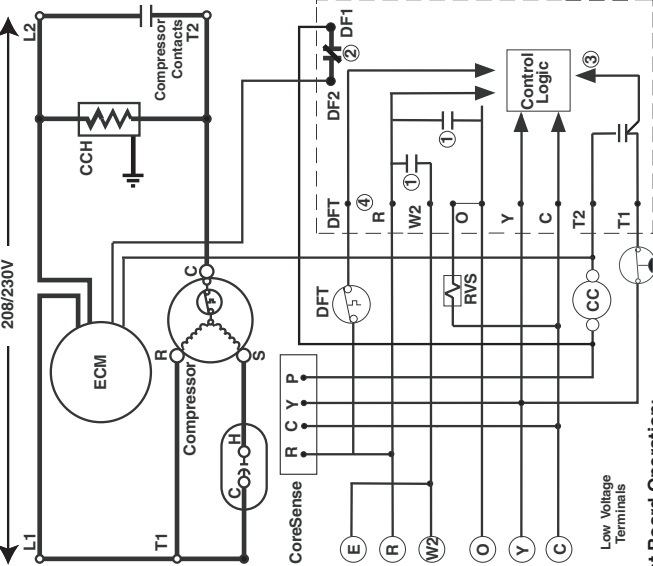

Defrost Board Operation:

1. Closing during defrost. Rating: 1 Amp. Max
2. Opens during defronst. Rating: 2HP at 230 Vac Max.
3. Closed when "y" is on. Open when "y" is off. Provides "off" delay time of 5 min. when "y" opens.
4. With DFT closed and "y" closed, compressor run time is accumulated. Opening of DFT during defrost or interval period resets the interval to 0.

ECM WIRING NOTES:

- 1) FOR 825 RPM ATTACH WHITE TO RIGHT CONTACTOR. (FOR SKU 919660,919661,919662,919664)
- 2) FOR 960 RPM ATTACH YELLOW TO RIGHT CONTACTOR. (FOR SKU 919663)
- 3) FOR 1100 RPM ATTACH WHITE AND YELLOW TO RIGHT CONTACTOR.

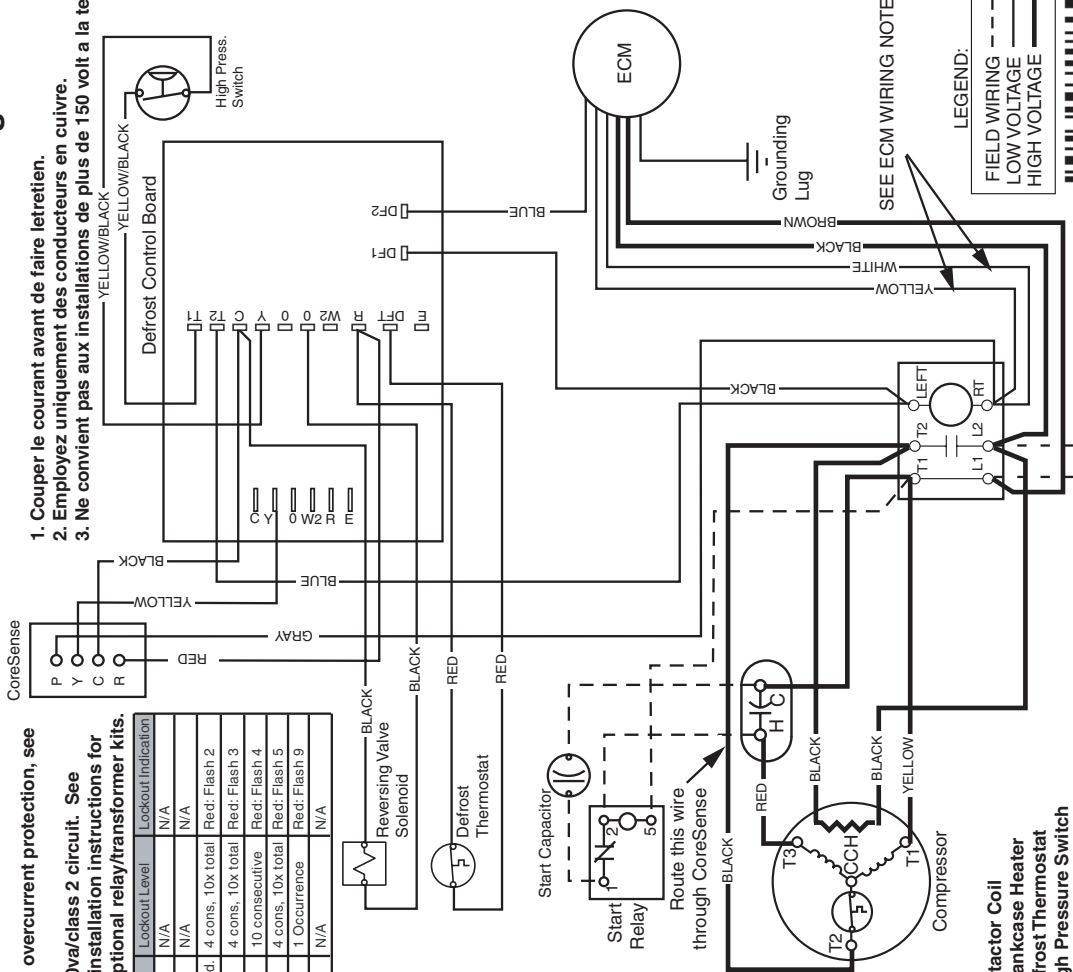

LEGEND:

- FIELD WIRING (dashed line)
- LOW VOLTAGE (solid line)
- HIGH VOLTAGE (thick solid line)



711205
01/13
(replaces 710660A)

Figure 15. Wiring Diagram for PSH4BE Series (1.5 to 3.5 Models with CoreSense™)

WIRING DIAGRAM

Split System Heat Pump (Outdoor Section)

- NOTES:
1. Disconnect all power before servicing.
 2. For supply connections use copper conductors only.
 3. Not suitable on systems that exceed 150 volts to ground
 4. For replacement wires use conductors suitable for 105° C.
 5. For ampacities and overcurrent protection, see unit rating plate.
 6. Connect to 24 vac/40va/class 2 circuit. See furnace/air handler installation instructions for control circuit and optional relay/transformer kits.

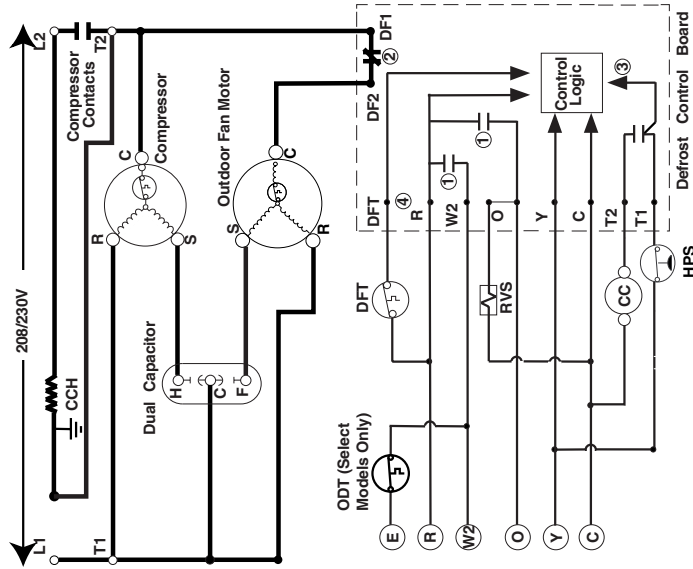

Defrost Board Operation:

- ① Closing during defrost. Rating: 1 Amp. Max.
- ② Opens during defrost. Rating: 2HP at 230 Vac Max.
- ③ Closed when "Y" is on, Open when "Y" is off.
Provides "off" delay time of 5 min. when "Y" opens.
- ④ With DFT closed and "Y" closed, compressor run time is accumulated. Opening of DFT during defrost or interval period resets the interval to 0.

Single Phase

1. Couper le courant avant de faire le retretien.
2. Employez uniquement des conducteurs en cuivre.
3. Ne convient pas aux installations de plus de 150 volt a la terre.

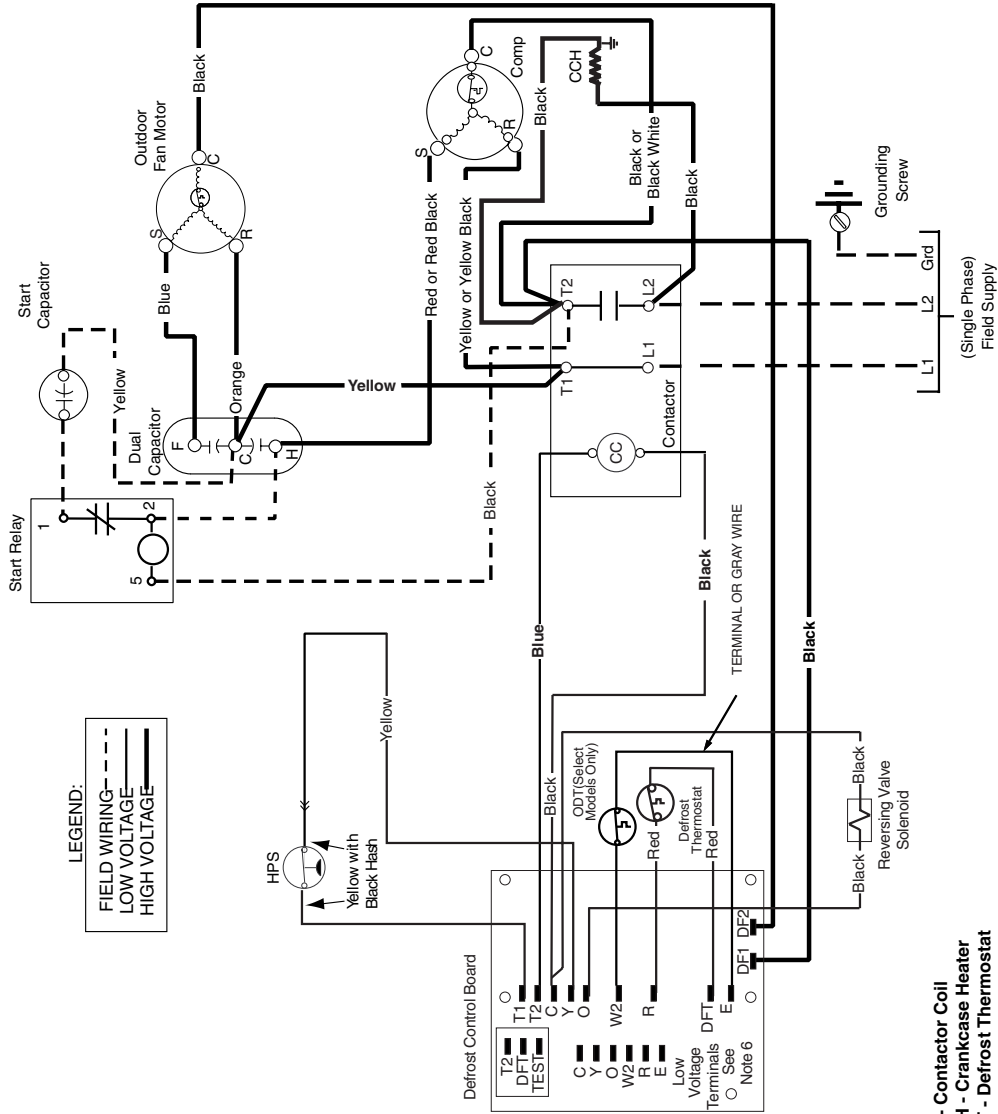

- CC - Contactor Coil
- CCH - Crankcase Heater
- DFT - Defrost Thermostat
- HPS - High Pressure Switch
- RVS - Reversing Valve Solenoid
- * - Hard Start Kit Field Installed
- ODT - Outdoor Thermostat



710507-D
(Replaces 710507-C)
05/11

Figure 16. Wiring Diagram for CSH4BE, DT4BE, ET4BE, JT4BE, & MSH4BE Series - (4 & 5 Ton Models)

WIRING DIAGRAM

Split system Heat Pump (Outdoor Section)

- NOTES:**
1. Disconnect all power before servicing.
 2. For supply connections use copper conductors only.
 3. Not suitable on systems that exceed 150 volts to ground.
 4. For replacement wires use conductors suitable for 105° C.
 5. For ampacities and overcurrent protection, see unit rating plate.
 6. Connect to 24 vac/40va/class 2 circuit. See furnace/air handler installation instructions for control circuit and optional relay/transformer kits.

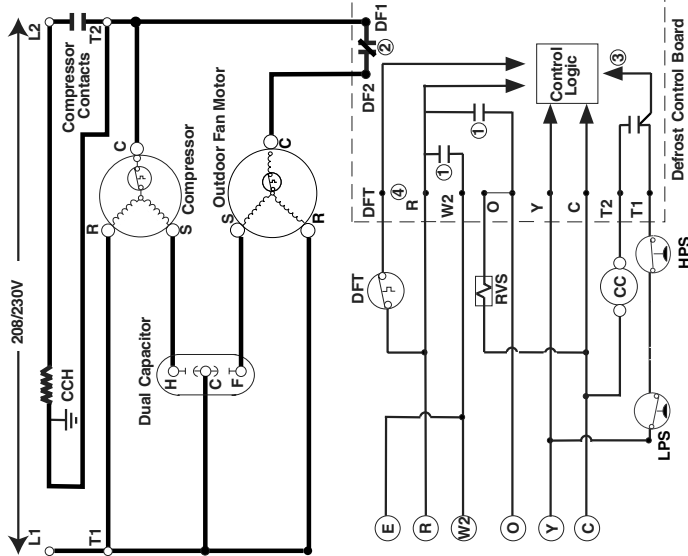

Defrost Board Operation:

1. Closing during defrost. Rating: 1 Amp. M.sx.
2. Opens during defrost. Rating: 2 HP at 230 Vac Max.
3. Closed when "Y" is on. Open when "Y" is off. Provides "off" delay time of 5 min. when "Y" opens.
- 4 With DFT closed and "Y" closed, compressor run time is accumulated. Opening of DFT during defrost or interval period resets the interval to 0.

Single Phase

1. Couper le courant avant de faire le rattrapage.
2. Employez uniquement des conducteurs en cuivre.
3. Ne convient pas aux installations de plus de 150 volt à la terre.

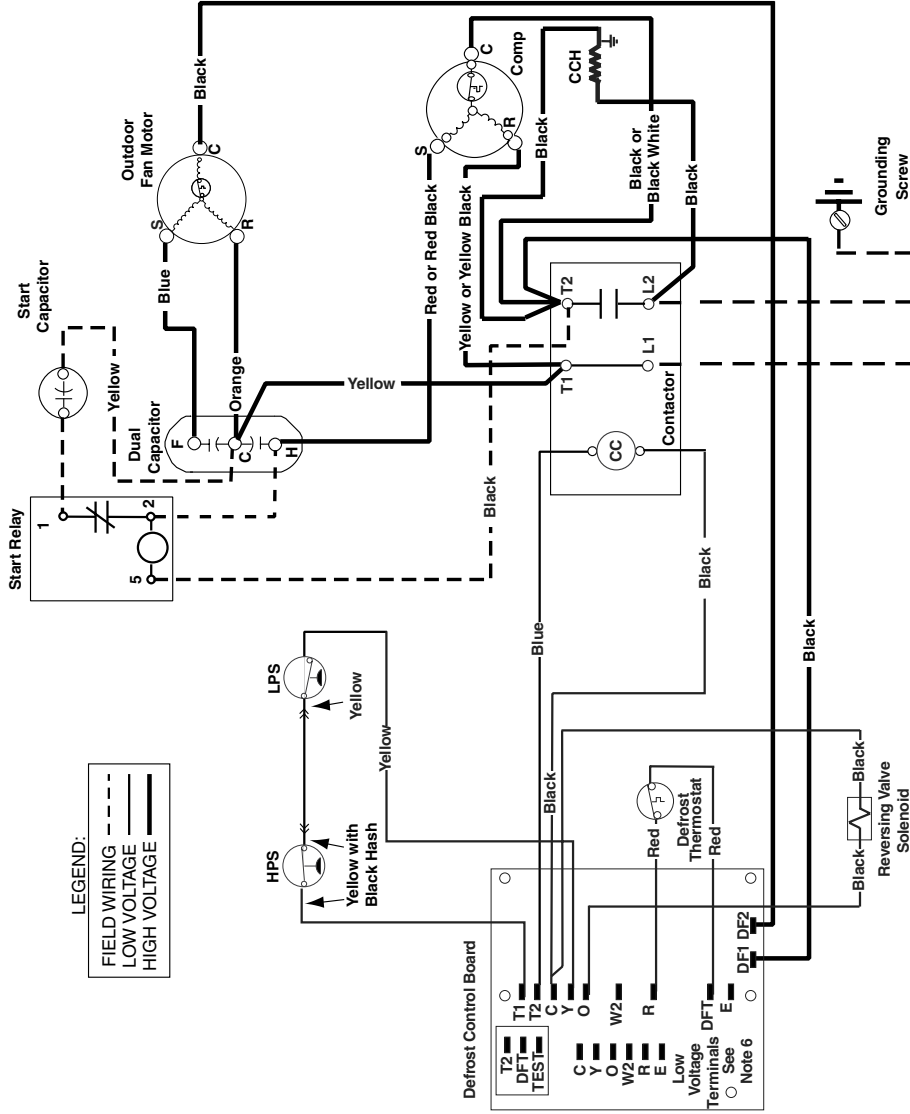

- CC - Contactor Coil
- CCH - Crankcase Heater
- DFT - Defrost Thermostat
- HPS - High Pressure Switch
- LPS - Low Pressure Switch
- RVS - Reversing Valve Solenoid
- * - Hard Start Kit Field Installed



710506B

710506B
(Replaces 710506A)

04/07

Figure 17. Wiring Diagram for FT4BE Series - (4 & 5 Ton Models)

WIRING DIAGRAM

Split System Heat Pump (Outdoor Section)

Single Phase

NOTES:

1. Disconnect all power before servicing.
2. For supply connections use copper conductors only.
3. Not suitable on systems that exceed 150 volts to ground.
4. For replacement wires use conductors suitable for 105° C.
5. For ampacities and overcurrent protection, see unit rating plate.
6. Connect to 24 vac/40va/class 2 circuit. See furnace/air handler installation instructions for control circuit and optional relay/transformer kits.

CoreSense Status LED	Status LED Description	Lockout Level	Lockout Indication
Normal Run: Solid Yellow	Normal Operation, no trip	N/A	N/A
Code 1: Yellow Flash 1	Long Run Time. Compressor running extremely long run cycle. (disabled in HP mode.)	N/A	N/A
Code 2: Yellow Flash 2	Compressor Pressure Trip. Disch. or suct. pressure out of limits or compressor overloaded.	4 cons, 10x total	Red: Flash 2
Code 3: Yellow Flash 3	Short Cycling. Compressor is running only briefly.	4 cons, 10x total	Red: Flash 3
Code 4: Yellow Flash 4	Locked Rotor.	10 consecutive	Red: Flash 4
Code 5: Yellow Flash 5	Compressor Moderate Run. Compressor runs > 15min, then trips > 7min.	4 cons, 10x total	Red: Flash 5
Code 9: Red Flash 19	Over Current Protection. PROT terminal has >2A input for more than 40ms	1 Occurrence	Red: Flash 9
Trip: Solid Red	Demand but compressor is not running	N/A	N/A

Instructions for control circuit and optional relay/transformer kits.

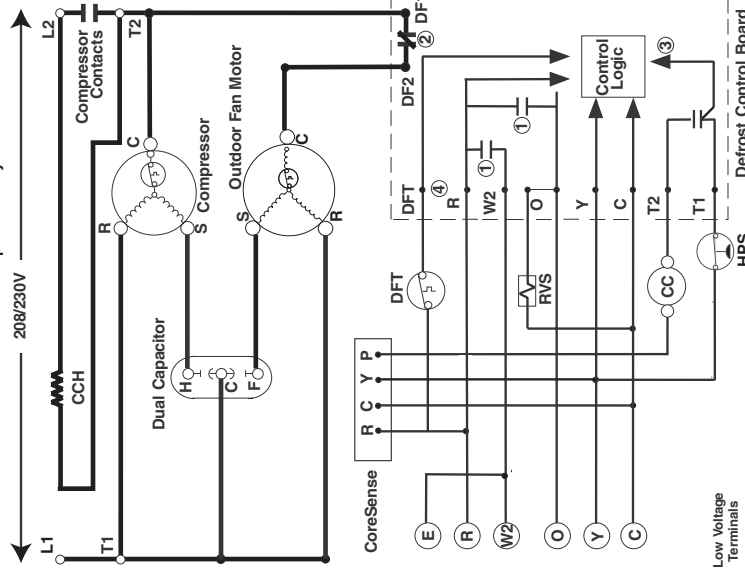

Defrost Board Operation:

1. Closing during defrost. Rating: 1 Amp. Max.
 2. Opens during defrost. Rating: 2 HP at 230Vac Max.
 3. Closed when "Y" is on. Open when "Y" is off.
 4. Provides "off" delay time of 5 min. when "Y" opens.
- With DFT closed and "Y" closed, compressor run time is accumulated. Opening of DFT during defrost or internal period resets the interval to 0.

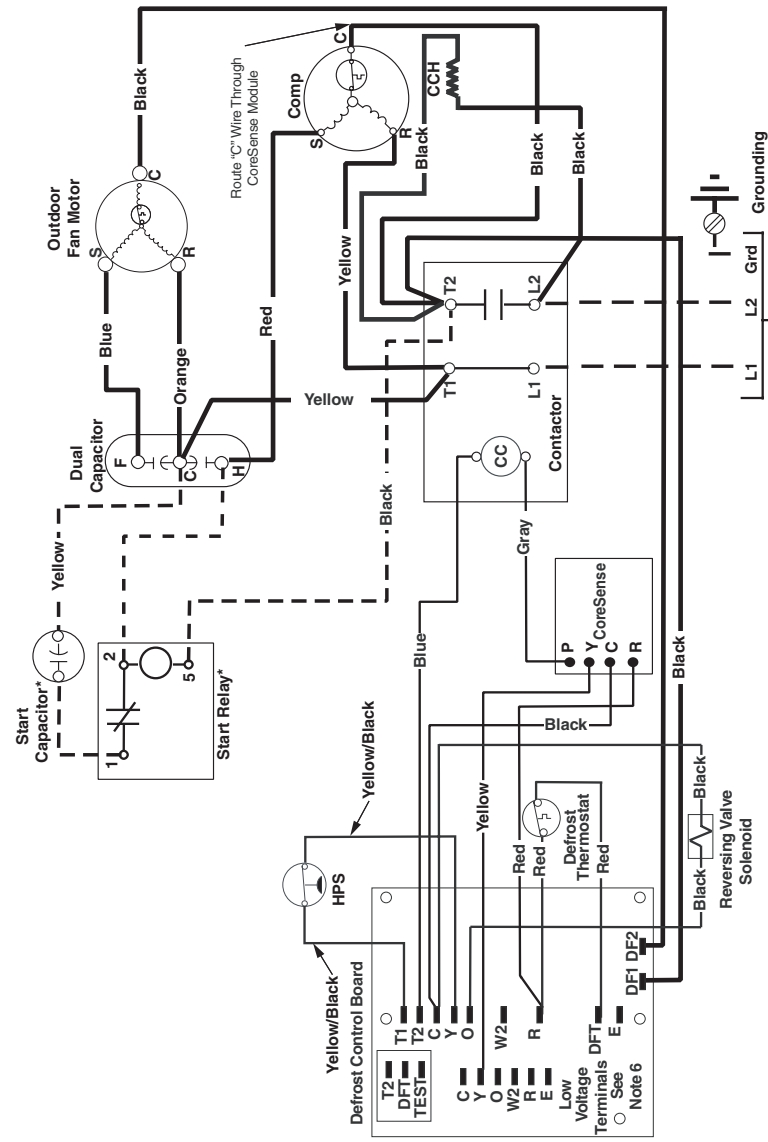

LEGEND:

- FIELD WIRING
- LOW VOLTAGE
- HIGH VOLTAGE

- CC - Contactor Coil
- CCH - Crankcase Heater
- DFT - Defrost Thermostat
- HPS - High Pressure Switch
- LPS - Low Pressure Switch
- RVS - Reversing Valve Solenoid
- * - Hard Start Kit Field Installed



711206
(Replaces 710533D)
1/13

Figure 18. Wiring Diagram for PSH4BE Series (4 & 5 Ton Models with CoreSense™)

INSTALLATION / PERFORMANCE CHECK LIST

INSTALLATION ADDRESS:		
CITY _____	STATE _____	
UNIT MODEL # _____		
UNIT SERIAL # _____		
Unit Installed Minimum clearances per Figure 1 (page 3)?	YES	NO
INSTALLER NAME:		
CITY _____	STATE _____	
Has the owner's information been reviewed with the customer?	YES	NO
Has the Literature Package been left with the unit?	YES	NO

REFRIGERATION SYSTEM		
Was unit given 24 hr warm up period for crankcase heaters?	YES	NO
Stage-1 Liquid Pressure (high side) _____		
Stage-1 Suction Pressure (low side) _____		

ELECTRICAL SYSTEM		
Electrical connections tight?	YES	NO
Line voltage polarity correct?	YES	NO
Rated Voltage: _____ VOLTS		
L1-L2 Volts: _____ VOLTS		
L1-L3 Volts: _____ VOLTS		
L2-L3 Volts: _____ VOLTS		
Avg. Volts: _____ VOLTS		
Max. deviation of voltage from avg. volts: _____ VOLTS		
% Volt imbalance: _____ VOLTS		
Blower Motor HP: _____ Sheave Setting _____ # Turns		
Has the thermostat been calibrated?	YES	NO
Is the thermostat level?	YES	NO
Is the heat anticipator setting correct? (If Applicable)	YES	NO

REPLACEMENT PARTS

Replacement parts are available through all your distributor. Please have the complete model and serial number of the unit when ordering replacement parts.

Electrical:

- | | |
|-------------------|----------------------------|
| Capacitors | Temperature Limit Switches |
| Compressors | Thermostats |
| Contactors | Time Delay Relays |
| Pressure Switches | Transformers |
| Relays | |

Motors:

- Blower Motor
- Fan Motor

Components:

- | | |
|------------------|---------------|
| Blower Assembly | Fan Grille |
| Cabinet Panels | Filter/Driers |
| Expansion Valves | |

