

# INSTALLATION INSTRUCTIONS

\*SH1BF4M2SX - 24K, 36K, 48K, & 60K (2, 3, 4, & 5 TON) - TWO-STAGE SERIES

## IMPORTANT

### ATTENTION INSTALLERS:

It is your responsibility to know this product better than your customer. This includes being able to install the product according to strict safety guidelines and instructing the customer on how to operate and maintain the equipment for the life of the product. Safety should always be the deciding factor when installing this product and using common sense plays an important role as well. Pay attention to all safety warnings and any other special notes highlighted in the manual. Improper installation of the unit or failure to follow safety warnings could result in serious injury, death, or property damage.

These instructions are primarily intended to assist qualified individuals experienced in the proper installation of this appliance. Some local codes require licensed installation/service personnel for this type of equipment. Please read all instructions carefully before starting the installation. Return these instructions to the customer's package for future reference.

**DO NOT DESTROY. PLEASE READ CAREFULLY & KEEP IN A SAFE PLACE FOR FUTURE REFERENCE.**

<b>IMPORTANT SAFETY INFORMATION.....</b>	<b>2</b>
<b>HEAT PUMP INSTALLATION.....</b>	<b>3</b>
General Information .....	3
Before You Install the Heat Pump.....	3
Locating the Heat Pump .....	3
Packaging Removal .....	3
Ground Level .....	3
Rooftop .....	3
Connecting Refrigerant Tubing Between the Indoor & Outdoor Unit .....	4
<b>ELECTRICAL WIRING .....</b>	<b>4</b>
Pre-Electrical Checklist .....	4
Line Voltage .....	4
Grounding .....	5
Thermostat / Low Voltage Connections .....	5
CoreSense™ Diagnostics Module.....	5
Compressor Protection .....	5
Resetting Alert Codes.....	5
Outdoor Fan Motor.....	6
Optional Equipment .....	6
Transformer Upgrade Kit .....	6
<b>START UP &amp; ADJUSTMENTS .....</b>	<b>6</b>
Pre-Start Check List.....	6
Start-Up Procedures .....	6
Operating Temperatures.....	6
Air Circulation - Indoor Blower .....	6
System Cooling.....	6
System Heating .....	7
Short Cycle Protection .....	7
Defrost Control Board Test Pins .....	7
<b>HEAT PUMP MAINTENANCE.....</b>	<b>7</b>
Panel Removal.....	7
Panel Installation.....	7
<b>REFRIGERANT CHARGING .....</b>	<b>8</b>
Charging the Unit in AC mode .....	8
If the outdoor temperature is 65 degrees F or higher:.....	8
If the outdoor temperature is between 35 degrees F and 65 degrees F: .....	9
If the outdoor temperature is below 35 degrees F:.....	9
<b>WIRING DIAGRAMS.....</b>	<b>10</b>
Figure 7. Wiring Diagram for 2 Ton Units With CoreSense™.....	10
Figure 8. Wiring Diagram for 3, 4, & 5 Ton Units With CoreSense™.....	11
<b>CORESENSE™ TROUBLESHOOTING .....</b>	<b>12</b>
Table 3. Coresense™ Diagnostics & LED Troubleshooting.....	12
<b>INSTALLATION CHECKLIST.....</b>	<b>16</b>
<b>REPLACEMENT PARTS .....</b>	<b>16</b>

## IMPORTANT SAFETY INFORMATION

INSTALLER: Please read all instructions before servicing this equipment. Pay attention to all safety warnings and any other special notes highlighted in the manual. Safety markings are used frequently throughout this manual to designate a degree or level of seriousness and should not be ignored.

**WARNING** indicates a potentially hazardous situation that if not avoided, could result in personal injury or death.

**CAUTION** indicates a potentially hazardous situation that if not avoided, may result in minor or moderate injury or property damage.

---

### **WARNING:**

---

#### **ELECTRICAL SHOCK, FIRE OR EXPLOSION HAZARD**

**Failure to follow safety warnings exactly could result in serious injury or property damage.**

**Improper servicing could result in dangerous operation, serious injury, death or property damage.**

- Before servicing, disconnect all electrical power to the unit.
  - When servicing controls, label all wires prior to disconnecting. Reconnect wires correctly.
  - Verify proper operation after servicing.
- 

---

### **WARNING:**

---

**This split system heat pump is shipped charged with R410A refrigerant and ready for installation. If repairs make it necessary for evacuation and charging, it should only be attempted by qualified trained personnel thoroughly familiar with this equipment. Under no circumstances should the owner attempt to install and/or service this equipment. Failure to comply with this warning could result in property damage, personal injury, or death.**

---

---

### **CAUTION:**

---

**This unit uses R-410A refrigerant. DO NOT use any other refrigerant in this unit. Use of another refrigerant will damage the unit.**

---

---

### **WARNING:**

---

**Unless noted otherwise in these instructions, only factory authorized parts or accessory kits may be used with this product. Improper installation, service, adjustment, or maintenance may cause explosion, fire, electrical shock or other hazardous conditions which may result in personal injury or property damage.**

---

- Installation of equipment may require brazing operations. Installer must comply with safety codes and wear appropriate safety equipment (safety glasses, work gloves, fire extinguisher, etc.) when performing brazing operations.
  - Follow all precautions in the literature, on tags, and on labels provided with the equipment. Read and thoroughly understand the instructions provided with the equipment prior to performing the installation and operational checkout of the equipment.
  - Use caution when handling this appliance or removing components. Personal injury can occur from sharp metal edges present in all sheet metal constructed equipment.
- 

---

### **WARNING:**

---

**The information listed below and the next page must be followed during the installation, service, and operation of this equipment. Failure to follow safety recommendations could result in possible damage to the equipment, serious personal injury or death.**

---

- The installer must comply with all local codes and regulations which govern the installation of this type of equipment. Local codes and regulations take precedence over any recommendations contained in these instructions. Consult local building codes and the National Electrical Code (ANSI C1) for special installation requirements.
- All electrical wiring must be completed in accordance with local, state and national codes and regulations and with the National Electric Code (ANSI/NFPA 70) or in Canada the Canadian Electric Code Part 1 CSA C.22.1.
- This equipment contains liquid and gaseous refrigerant under high pressure. **DO NOT USE ANY PORTION OF THE CHARGE FOR PURGING OR LEAK TESTING.** Installation or servicing should only be performed by qualified trained personnel thoroughly familiar with this type equipment.
- Fully annealed, refrigerant grade copper tubing should be used when installing the system. Refrigerant suction line tubing should be fully insulated.
- This unit is designed for outdoor installations only and should be positioned as described on [page 3](#).

## HEAT PUMP INSTALLATION

### General Information

Split system heat pumps are designed only for outdoor rooftop or ground level installations. This unit has been tested for capacity and efficiency in accordance with AHRI Standards and will provide many years of safe and dependable comfort, provided it is properly installed and maintained. Abuse, improper use, and/or improper maintenance can shorten the life of the appliance and create unsafe hazards.

To achieve optimum performance and minimize equipment failure, it is recommended that periodic maintenance be performed on this unit. The ability to properly perform maintenance on this equipment requires certain mechanical skills and tools.

### Before You Install the Heat Pump

- ✓ The cooling load of the area to be conditioned must be calculated and a system of the proper capacity selected. It is recommended that the area to be conditioned be completely insulated and vapor sealed.
- ✓ Check the electrical supply and verify the power supply is adequate for unit operation. The system must be wired and provided with circuit protection in accordance with local building codes. If there is any question concerning the power supply, contact the local power company.
- ✓ The indoor section (air handler, furnace, etc) should be installed before routing the refrigerant tubing. Refer to the indoor unit's installation instructions for installation details.
- ✓ All units are securely packed at the time of shipment and upon arrival should be carefully inspected for damage prior to installing the equipment at the job site. Verify coil fins are straight. If necessary, comb fins to remove flattened or bent fins. Claims for damage (apparent or concealed) should be filed immediately with the carrier.
- ✓ Please consult your dealer for maintenance information and availability of maintenance contracts. Please read all instructions before installing the unit.

### Locating the Heat Pump

- Survey the job site to determine the best location for mounting the outdoor unit.
- Overhead obstructions (Figure 1), poorly ventilated areas, and areas subject to accumulation of debris should be avoided.
- Sufficient clearance for unobstructed airflow through the outdoor coil must be maintained in order to achieve rated performance. See Figure 1 for minimum clearances to obstructions.
- Consideration should be given to availability of electric power, service access, noise, and shade.

### Packaging Removal

To prevent damage to the tubing connections, carefully remove the carton and user's manual from the equipment. Discard the shipping carton.

### Ground Level

Ground level installations must be located according to local building codes or ordinances and these requirements:

- Clearances must be in accordance with those shown in Figure 1.
- A suitable mounting pad must be provided and be separate from the building foundation. The pad must be level and strong enough to support the unit's weight. The slab height must be a minimum of 2" (5 cm) above grade and with adequate drainage. See Figure 1.

### Rooftop

- The method of mounting should be designed so that it does not overload roof structures or transmit noise to the interior of the structure. The roof must be structurally capable of handling the weight of the unit.
- Full perimeter support is required under the unit. Support must be made of weather resistant materials and installed prior to unit installation.
- The support must be built to raise the unit 6" above the roof.

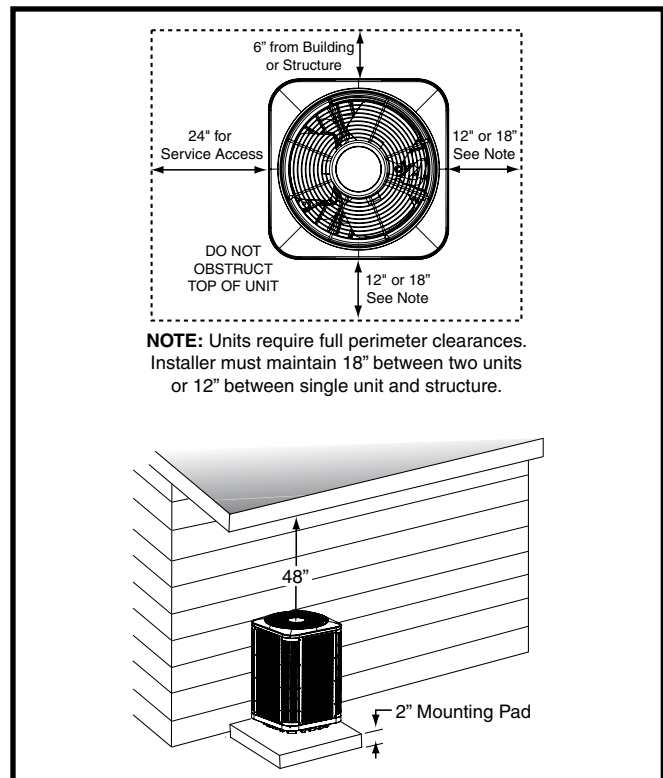

Figure 1. Clearance Requirements

### **CAUTION:**

**When servicing, cover or seal openings to minimize the exposure of the refrigerant system to air to prevent accumulation of moisture and other contaminants.**

---

After outdoor and indoor unit placement has been determined, route refrigerant tubing between the equipment in accordance with sound installation practices.

- When connecting refrigerant linesets together, it is recommended that dry nitrogen be flowing through the joints during brazing. This will prevent internal oxidation and scaling from occurring.
- Refrigerant tubing should be routed in a manner that minimizes the length of tubing and the number of bends in the tubing.
- Refrigerant tubing should be supported in a manner that the tubing will not vibrate or abrade during system operation.
- Tubing should be kept clean of foreign debris during installation.
- Every effort should be made by the installer to ensure that the field installed refrigerant containing components of the system have been installed in accordance with these instructions and sound installation practices to insure reliable system operation and longevity.
- The maximum recommended interconnecting refrigerant line length is 75 feet, and the vertical elevation difference between the indoor and outdoor sections should not exceed 20 feet.
- If precise forming of refrigerant lines is required, a copper tubing bender is recommended. Avoid sharp bends and contact of the refrigerant lines with metal surfaces.
- A filter dryer is provided with the unit and must be installed in the liquid line of the system. If the installation replaces a system with a filter dryer already present in the liquid line, the filter dryer must be replaced with the one supplied with the unit. The filter dryer must be installed in strict accordance with the manufacturer's installation instructions.
- Optional equipment such as liquid line solenoid valves, low ambient, etc., should be installed in strict accordance with the manufacturer's installation instructions.

### **WARNING:**

#### **ELECTRICAL SHOCK, FIRE OR EXPLOSION HAZARD**

**Failure to follow safety warnings exactly could result in serious injury or property damage.**

**Improper servicing could result in dangerous operation, serious injury, death or property damage.**

- **Before servicing, disconnect all electrical power to the unit.**
  - **When servicing controls, label all wires prior to disconnecting. Reconnect wires correctly.**
  - **Verify proper operation after servicing.**
- 

- All electrical connections must be in compliance with all applicable local codes and ordinances, and with the current revision of the National Electric Code (ANSI/NFPA 70).
- For Canadian installations the electrical connections and grounding shall comply with the current Canadian Electrical Code (CSA C22.1 and/or local codes).

#### **Pre-Electrical Checklist**

- ✓ Verify that the voltage, frequency, and phase of the supply source match the specifications on the unit rating plate.
- ✓ Verify that the service provided by the utility is sufficient to handle the additional load imposed by this equipment. Refer to the unit wiring label for proper high and low voltage wiring.
- ✓ Verify factory wiring is in accordance with the units wiring diagram. See [Figure 7, \(page 10\)](#), & [Figure 8, \(page 11\)](#). Inspect for loose connections.

#### **Line Voltage**

- A wiring diagram is located on the inside cover of the electrical box of the outdoor unit. The installer should become familiar with the wiring diagram before making any electrical connections to the outdoor unit.
- **An electrical disconnect must be located within sight of and readily accessible to the unit.** This switch shall be capable of electrically de-energizing the outdoor unit.
- Line voltage to the unit should be supplied from a dedicated branch circuit containing the correct fuse or circuit breaker for the unit. Incoming field wiring and minimum size of electrical conductors and circuit protection must be in compliance with information listed on the outdoor unit data label. Any other wiring methods must be acceptable to authority having jurisdiction.
- The outdoor unit requires both power and control circuit electrical connections. Refer to the wiring diagrams for identification and location of outdoor unit field wiring interfaces. See [Figure 7, \(page 10\)](#), & [Figure 8, \(page 11\)](#). Make all electrical connections in accordance with all applicable codes and ordinances.
- Overcurrent protection must be provided at the branch circuit distribution panel and sized as shown on the unit rating label and according to applicable local codes. See the unit rating plate for minimum circuit ampacity and maximum overcurrent protection limits.
- Provide power supply for the unit in accordance with the unit wiring diagram, and the unit rating plate. Connect the

line-voltage leads to the terminals on the contactor inside the control compartment.

- Use only copper wire for the line voltage power supply to this unit in strict accordance of the NEC (ANSI/NFPA 70), applicable local codes, and the instructions provided with the equipment. Use proper code agency listed conduit and a conduit connector for connecting the supply wires to the unit. Use of rain tight conduit is recommended.
- 208/230 Volt units are shipped from the factory wired for 230 volt operation. For 208V operation, remove the lead from the transformer terminal marked 240V and connect it to the terminal marked 208V.
- Optional equipment requiring connection to the power or control circuits must be wired in strict accordance of the NEC (ANSI/NFPA 70), applicable local codes, and the instructions provided with the equipment.
- For 2 ton units only: Jumper together Y/Y2 and Y1 on the indoor unit's control board so that the indoor unit operates in second stage when operating in cooling mode.

## Grounding

### **WARNING:**

**The unit cabinet must have an uninterrupted or unbroken electrical ground to minimize personal injury if an electrical fault should occur. Do not use gas piping as an electrical ground!**

This unit must be electrically grounded in accordance with local codes or, in the absence of local codes, with the National Electrical Code (ANSI/NFPA 70) or the CSA C22.1 Electrical Code. Use the grounding lug provided in the control box for grounding the unit.

### Thermostat / Low Voltage Connections

- Thermostat connections should be made in accordance with the instructions supplied with the thermostat and the indoor equipment. A typical installation with a heat pump thermostat and air handler is shown in [Figure 2](#).
- The outdoor unit is designed to operate from a 24 VAC Class II control circuit. The control circuit wiring must comply with the current provisions of the NEC (ANSI/NFPA 70) and with applicable local codes having jurisdiction.
- The low voltage wires must be properly connected to the unit's defrost control board.
- The thermostat should be mounted about 5 feet above the floor on an inside wall. DO NOT install the thermostat on an outside wall or any other location where its operation may be adversely affected by radiant heat from fireplaces, sunlight, or lighting fixtures, and convective heat from warm air registers or electrical appliances. Refer to the thermostat manufacturer's instruction sheet for detailed mounting and installation information.

### CoreSense™ Diagnostics Module

(Select Models Only)

The CoreSense™ Diagnostics Module ([Figure 3](#)) is a breakthrough innovation for troubleshooting heat pump and air conditioning system failures. The module installs easily in the electrical box of the outdoor unit near the compressor contactor. By using the compressor as a sensor, CoreSense Diagnostics helps the service technician more accurately troubleshoot system and compressor fault conditions.

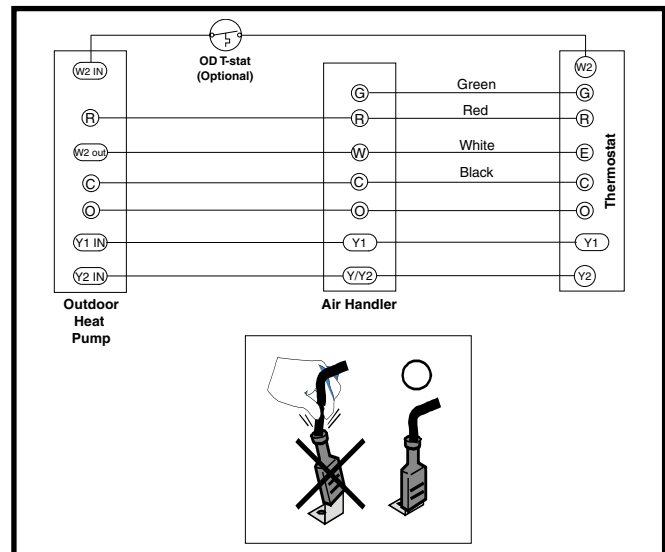

**Figure 2. Typical 2 - Stage Heat Pump w/ Optional Outdoor Thermostat and Variable Speed Air Handler**

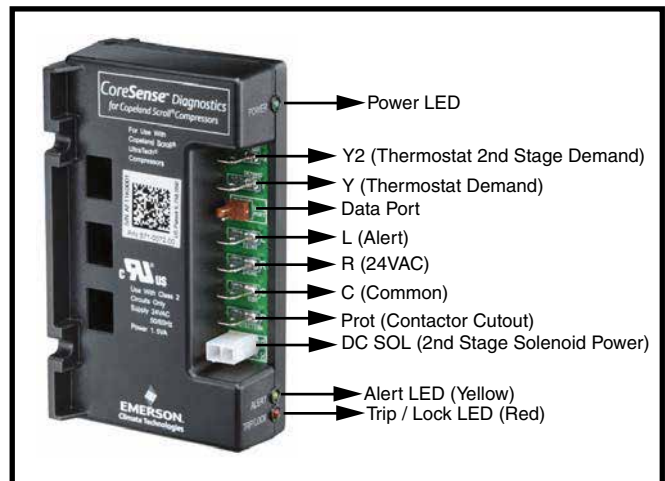

**Figure 3. CoreSense™ Diagnostics Module**

A flashing LED indicator communicates the ALERT code and a diagnostic key is also imprinted on the side of the module to quickly direct the technician to the root cause of a problem. Alert identification codes are also listed in [Table 3, \(page 12\)](#).

### Compressor Protection

The CoreSense™ Diagnostics module utilizes proprietary algorithms to protect the compressor and system from repeated trips of system pressure controls and the compressor internal overload. The protection terminal of the module should be wired in series with the system low pressure and high pressure cutouts, as well as the compressor contactor. When the module detects a series of trips as described below, it will activate a lockout feature that opens the normally closed protection contacts in the module, thereby cutting power to the contactor and shutting off the compressor.

### Resetting Alert Codes

When the CoreSense™ Diagnostics module has detected a series of adverse conditions that have caused it to lockout the compressor, and after the issue has been resolved, it is necessary to manually reset the module in order to clear the present alert code.

The primary way of clearing the code and resetting the alert is to press the reset button located on the module.

**NOTE:** Pressing the reset will require a pin or a mini electronics screwdriver. This button must be pressed and held for a minimum of one second for the module to be reset. Pressing the reset button clears the immediate lock code and the seven day operating history. It will not clear the permanent module history. In the case of the three-wire module, the codes can be reset or cleared by cycling power to the module. This can be done by disengaging the Common (C) terminal. This will not clear the seven day operating history.

### Outdoor Fan Motor

If the unit utilizes a 2-speed condenser fan motor, this motor will operate on low speed when in low cooling, and on high speed when in high cooling. A relay within the control area switches the fan motor from low to high speed using the call for high cooling as the trigger. Other models that utilize BLDC fixed torque variable speed fan motors will not require a relay.

### Optional Equipment

Optional equipment requiring connection to the power or control circuits must be wired in strict accordance with current provisions of the NEC (ANSI/NFPA 70), with applicable local codes having jurisdiction, and the installation instructions provided with the equipment. Optional Equipment (low ambient control, hard start kits, etc.) should be installed in strict accordance with the manufacturer's installation instructions. A functional checkout should be performed in accordance with the checkout procedures supplied with the equipment.

### Transformer Upgrade Kit

If this 2-stage heat pump is installed in conjunction with a gas furnace and fossil fuel kit, the furnace transformer **MUST** be upgraded to one with a 60 VA rating or using the transformer upgrade kit (904077). To upgrade the transformer:

- Remove the existing transformer and install the new 60 VA transformer.
- Remove the 3 amp fuse on the furnace control board and install the 5 amp fuse provided.

**NOTE:** The new transformer may be larger than the existing transformer that is mounted in the furnace. If this happens, mount the 60 VA transformer using one of the mounting holes in the furnace panel. On the other side either drill a 0.149 hole in the panel and use the existing fastener, or use a self-drilling fastener to secure the other side of the transformer.

COOLING		HEATING	
MIN (°F)	MAX (°F)	MIN (°F)	MAX (°F)
60	115	-10	70

**Table 1. Heat Pump Operating Temperatures**

## START UP & ADJUSTMENTS

### Pre-Start Check List

- ✓ Verify the unit is level and has sufficient clearances for unobstructed airflow.
- ✓ Verify the outdoor coil and top of the unit are free from obstructions and debris, and all equipment access/control panels are in place.
- ✓ Verify that the line voltage power leads are securely connected and the unit is properly grounded.
- ✓ Verify that the low voltage wires are securely connected to the correct leads on the low voltage terminal strip.
- ✓ Verify that the power supply branch circuit overcurrent protection is sized properly.
- ✓ Verify that the thermostat is wired correctly.

### Start-Up Procedures

## WARNING:

**This unit is equipped with a crankcase heater. Allow 24 hours prior to continuing the start up procedures to allow for heating of the refrigerant compressor crankcase. Failure to comply may result in damage and could cause premature failure of the system. This warning should be followed at initial start up and any time the power has been removed for 12 hours or longer.**

### Operating Temperatures

This equipment has been designed to operate within the temperatures specified in [Table 1](#). Running the equipment in heating at higher than 70° F may require the use of a Heat Pump Mild Weather Control Kit or changing over to emergency or auxiliary heating.

### Air Circulation - Indoor Blower

1. Set the thermostat system mode on OFF and the fan mode to ON.
2. Verify the blower runs continuously. Check the air delivery at the supply registers and adjust register openings for balanced air distribution. If insufficient air is detected, examine ductwork for leaks or obstructions.
3. Set the thermostat fan mode to AUTO and verify the blower stops running.

### System Cooling

1. Set the thermostat's system mode to COOL and the fan mode to AUTO. Gradually lower the thermostat temperature setpoint below room temperature and verify the outdoor unit and indoor blower energize.
2. Verify blower wheel is spinning in direction indicated by arrow. Feel the air being circulated by the indoor blower and verify that it is cooler than ambient temperature. Listen for any unusual noises. If unusual sounds occur, determine the source of the noise and correct as necessary.
3. Verify HI and LO refrigerant pressures.
4. Allow the system to operate for several minutes and then set the temperature selector above room temperature. Verify the fan and compressor cycle off with the thermostat.

**NOTE:** The blower should also stop unless fan switch is set to the ON position.

## HEAT PUMP MAINTENANCE

### **WARNING:**

**To prevent electrical shock, personal injury, or death, disconnect all electrical power to the unit before performing any maintenance or service. The unit may have more than one electrical supply.**

Proper maintenance is important to achieve optimum performance from the heat pump. The ability to properly perform maintenance on this equipment requires certain mechanical skills and tools. If you do not possess these skills, contact your dealer for maintenance. Consult your local dealer about the availability of maintenance contracts. Routine maintenance should include the following:

- Inspect the electrical connections for tightness at the beginning of each heating and cooling season. Service as necessary.
- Inspect and clean or replace air filters at the beginning of each heating and cooling season, or more frequently if required.

### **CAUTION:**

**The unit should never be operated without a filter in the return air system. Replace disposable filters with the same type and size.**

- Inspect the outdoor coil at the beginning of each cooling season. Remove any debris. Clean the outdoor coil and louvers as necessary using a mild detergent and water. Rinse thoroughly with water.
- Do not add additional oil to motors unequipped with oil tubes. The compressor is hermetically sealed at the factory and does not require lubrication.

#### **Panel Removal**

1. Remove screws securing the panel.
2. Slide the panel up towards the top pan in order to clear the bottom flange from the base pan. See [Figure 4, \(page 8\)](#).
3. Swing the bottom of the panel out and pull the panel down to remove it from the unit.

#### **Panel Installation**

1. Insert the top corners of side panel flanges into the corner post channels as shown in Detail A in [Figure 5, \(page 8\)](#).
2. Slide the panel up into the top pan. (You may need to push on the center of the panel at the top in order to clear the top pan edge).
3. Swing the panel in and push down until the panel is resting on the top edge of the base pan wall as shown in Detail B.
4. Insert screws into the panel to secure it to the unit.

### System Heating

1. Set the thermostat's system mode to HEAT and the temperature mode to below room temperature.
2. Verify the outdoor unit and indoor fan stop running. After 5 minutes, increase the temperature on the thermostat to it's maximum setting.
3. Verify the outdoor unit and indoor blower energize. Feel the air being circulated by the indoor blower and verify that it is warmer than ambient temperature. Listen for any unusual noises. If unusual sounds occur, determine the source of the noise and correct as necessary.

**NOTE:** Other sources for heating (electric furnace, fossil fuel furnace, air handler with electric heat options, etc.) that interface with the heat pump should be functionally checked to verify system operation and compatibility with the heat pump. Refer to the installation instructions for this equipment and perform a functional checkout in accordance with the manufacturer's instructions.

### **Short Cycle Protection**

1. With the system operating in COOLING mode, record the setpoint temperature setting of the thermostat.
2. Gradually raise the setpoint temperature until the outdoor unit and indoor blower de-energize.
3. Immediately lower the setpoint temperature of the thermostat to its original setting and verify that the indoor blower is energized and that the outdoor unit remains de-energized.
4. After approximately 5 minutes, verify that the outdoor unit energizes and the temperature of the air supplied to the facility is cooler than ambient temperature.

### **Defrost Control Board Test Pins**

- Placing a jumper between the test pins for less than 1 second will bypass the Anti-Short Cycle Timer.
- Placing a jumper between the test pins for more than 1 second will force the unit into a defrost cycle. As soon as the jumper is removed, the defrost cycle will end as determined by the typical criteria.
- Verify the Status Indicator (on the control board) against the codes listed in [Table 2](#) to determine proper diagnostic description.

STATUS INDICATOR	STATUS TYPE	DIAGNOSTIC DESCRIPTION
C1	Operating Status	Cooling, 1st Stage
C2	Operating Status	Cooling, 2nd Stage
H1	Operating Status	Heating, 1st Stage
H2	Operating Status	Heating, 2nd Stage
SC	Operating Status	Anti Short Cycle Timer
DF	Operating Status	Defrost
--	Operating Status	Power on, no call for operation
D1	Fault	Pressure switch, low
D2	Fault	Pressure switch, high
D3	Fault	Temperature Sensor, Ambient
D4	Fault	Temperature Sensor, Coil
D5	Fault	Board
DF (FLASHING)	Input Error	Forced defrost - test short applied longer than 11 minutes

**Table 2. Defrost Control Board Status Indicators**

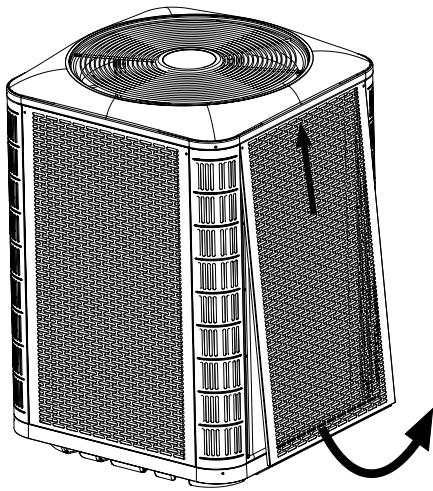

Figure 4. Panel Removal

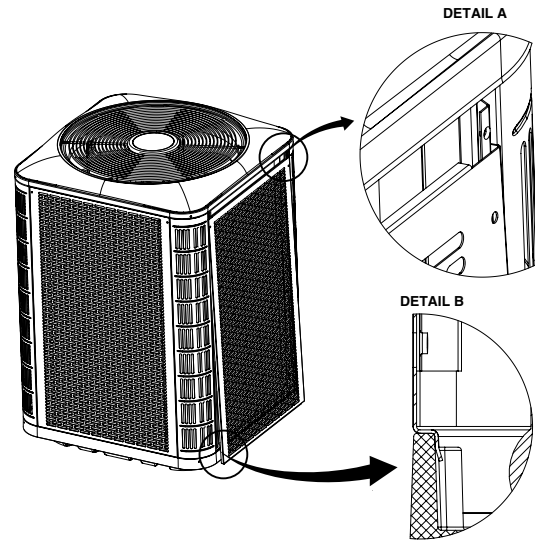

Figure 5. Panel Installation

## REFRIGERANT CHARGING

### **⚠ WARNING:**

**This split system heat pump is shipped charged with R410A refrigerant and ready for installation. If repairs make it necessary for evacuation and charging, it should only be attempted by qualified trained personnel thoroughly familiar with this equipment. Under no circumstances should the owner attempt to install and/or service this equipment. Failure to comply with this warning could result in property damage, personal injury, or death.**

After refrigerant line connections are completed, it is required that you leak check and evacuate the indoor section and all line connections (using proper methods) before finalizing the full system refrigerant charge.

- To achieve rated capacity and efficiency, the compressor must be exposed to refrigerant for at least 24 hours prior to running and then the compressor must be run for a minimum of 12 hours.
- The refrigerant charge can be checked and adjusted through the service ports provided external to the outdoor unit. Use only gage line sets which have a “Schrader” depression device present to actuate the valve. A common suction port for heating mode charging is included and located on the compressor access panel above the outdoor unit service valves.
- A high-pressure switch is factory installed and located internally on the compressor discharge line of the outdoor unit. If the discharge pressure rises above 650 psig, the switch will open and de-energize the outdoor unit. The switch will close again after the discharge pressure decreases to 460 psig. **NOTE:** When the switch opens and then closes, there will be a 3 minute short cycling delay before the outdoor unit will energize. Under normal conditions the switch is closed
- A low-pressure switch is factory installed (certain models) and located internally on the suction line of the outdoor unit. The switch is designed to protect the compressor from a

loss of charge by interrupting the thermostat inputs to the unit. If the suction pressure falls below 20 psig, the switch will open and de-energize the outdoor unit. The switch will close again when the suction pressure increases above 35 psig. When the switch opens and then closes, there is a 3 minute short cycling delay before the outdoor unit will energize. Under normal conditions the switch is closed.

To properly charge these units:

1. Read all Installation Instructions first.
2. Complete any brazing operations. (e.g. Split system line-sets)
3. Leak check and evacuate the whole system using proper methods.
4. Purge the nitrogen holding charge.
5. Evacuate the unit to 350-500 microns.
6. Allow the unit to remain under vacuum for at least 30 min.
7. Weigh-In the proper amount of new (or reclaimed) R-410A refrigerant. Refer to the units Quick Reference Data Sheet to determine the correct amount of charge.

### **Charging the Unit in AC mode**

*If the outdoor temperature is 65 degrees F or higher:*

After completing the refrigerant line connections, leak checking the system, and evacuating the indoor section and all line connections (using proper methods), perform the following steps:

1. Determine the recommended charge addition (if applicable) for the system being installed. This information is in the unit’s QRD (Quick Reference Data sheet).
2. Calculate the amount of additional refrigerant needed for the line set length of the actual installation. This information is on the first page of the unit’s QRD (Quick Reference Data sheet).
3. Weigh in the additional charge amounts determined by step 1 and 2 above.
4. Adjust the charge to match the superheat (for fixed orifice systems) or subcooling (for TXV systems). There are three different resources for doing this:
  - a.) The [chargecalculator.com](http://chargecalculator.com) website. This will walk you through the charging process step by step.
  - b.) The charging tables on the inside of the outdoor unit’s electrical box cover panel. These tables

provide superheat targets for fixed orifice systems and subcooling targets for TXV systems. The system should be charged so that the measured superheat/subcooling are within 1 degree F of the target listed in the table.

**For fixed orifice systems:**

- If your measured superheat at the suction valve is **LESS THAN** the recommended superheat value in the table then **REMOVE** refrigerant.
- If your measured superheat at the suction valve is **GREATER THAN** the recommended superheat value in the table then **ADD** refrigerant.

**For TXV systems:**

- If your measured subcooling at the liquid valve is **LESS THAN** the recommended subcooling value in the table then **ADD** refrigerant.
- If your measured subcooling at the liquid valve is **GREATER THAN** the recommended subcooling value in the table then **REMOVE** refrigerant.

- c.) The charging tables in the Supplemental Charging Information, can be found online in the literature library. The tables can also be accessed by scanning the QR code on the unit's electrical panel. The pressures listed in these tables are for reference only and are to be used in troubleshooting a system. The system should be charged to match the superheat or subcooling targets as previously noted and not to match the system pressures. Follow the same procedure described in 4b above.

*If the outdoor temperature is between 35 degrees F and 65 degrees F:*

After completing the refrigerant line connections, leak checking the system, and evacuating the indoor section and all line connections (using proper methods), perform the following steps:

1. Determine the recommended charge addition (if applicable) for the system being installed. This information is in the unit's QRD (Quick Reference Data sheet).
2. Calculate the amount of additional refrigerant needed for the line set length of the actual installation. This information is on the first page of the unit's QRD (Quick Reference Data sheet).
3. Weigh in the additional charge amounts determined by step 1 and 2 above.
4. Block off the discharge of the outdoor fan. **NOTE:** One half of the unit should be covered corner to corner as shown in [Figure 6](#).
5. With the unit in cooling mode, Adjust the charge to match the superheat (for fixed orifice systems) or subcooling (for TXV systems). There are two different resources for doing this:
  - a.) The [chargecalculator.com](http://chargecalculator.com) website. This will walk you through the charging process step by step.
  - b.) The low ambient charging tables on the inside of the outdoor unit's electrical box cover panel. These tables provide superheat targets for fixed orifice systems and subcooling targets for TXV systems. The system should be charged so that the measured superheat/subcooling are within 1 degree F of the target listed in the table.

**For fixed orifice systems:**

- If your measured superheat at the suction valve is **LESS THAN** the recommended superheat value in the table then **REMOVE** refrigerant.
- If your measured superheat at the suction valve is **GREATER THAN** the recommended superheat value in the table then **ADD** refrigerant.

**For TXV systems:**

- If your measured subcooling at the liquid valve is **LESS THAN** the recommended subcooling value in the table then **ADD** refrigerant.
- If your measured subcooling at the liquid valve is **GREATER THAN** the recommended subcooling value in the table then **REMOVE** refrigerant

*If the outdoor temperature is below 35 degrees F:*

After completing the refrigerant line connections, leak checking the system, and evacuating the indoor section and all line connections (using proper methods), perform the following steps:

1. Determine the recommended charge addition (if applicable) for the system being installed. This information is in the unit's QRD (Quick Reference Data sheet).
2. Calculate the amount of additional refrigerant needed for the line set length of the actual installation. This information is on the first page of the unit's QRD (Quick Reference Data sheet).
3. Weigh in the additional charge amounts determined by steps 1 and 2 above.
4. Return to the system when the outdoor temperature is 35 degrees F or higher and follow the steps defined in step 4 of the "If the outdoor temperature is between 35 degrees and 65 degrees F" or "If the outdoor temperature is 65 degree F or higher" sections above as applicable.

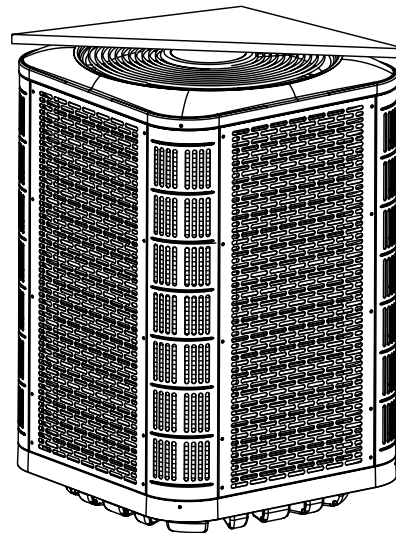

**NOTE:** One half of the unit should be covered corner to corner.

**Figure 6. Blocked Off Outdoor Fan Discharge**

# WIRING DIAGRAMS

## WIRING DIAGRAM

**Two Stage Split System Heat Pump (Outdoor Section) With CoreSense and PSC Fan Motor**      **208/230V**      **Single Phase / 60 Hz.**

- NOTES:**
1. Disconnect all power before servicing.
  2. For supply connections use copper conductors only.
  3. Not suitable on systems that exceed 150 volts to ground.
  4. For replacement wires use conductors suitable for 105 °C
  5. For ampacities and overcurrent protection, see unit rating plate.
  6. Connect to 24 vac/40va/class 2 circuit. See furnace/airhandler installation instructions for control circuit and optional relay/transformer kits.

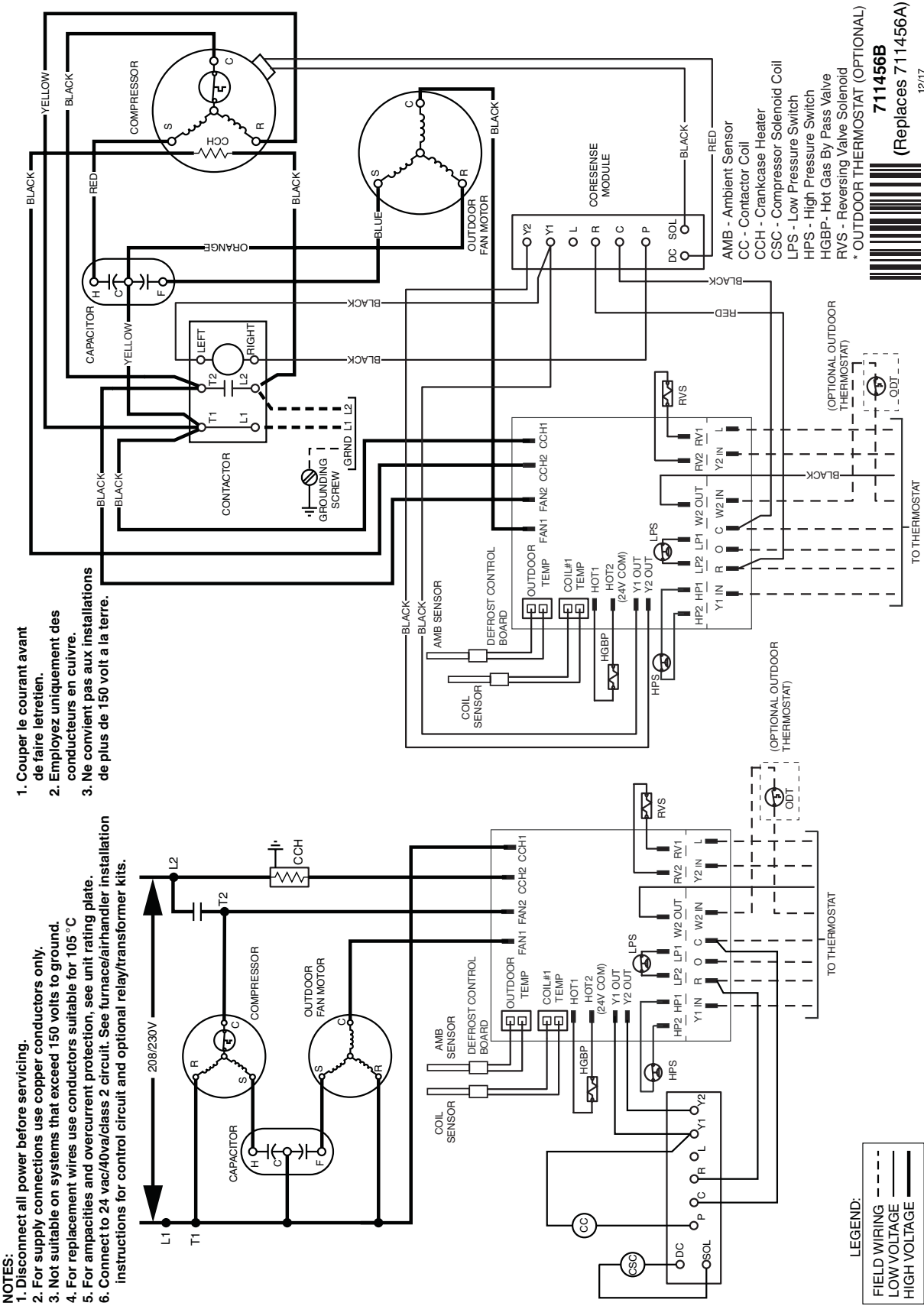

Figure 7. Wiring Diagram for 2 Ton Units With CoreSense™

# WIRING DIAGRAM

Two Stage Split System Heat Pump (Outdoor Section) With CoreSense and ECM Fan Motor 208/230V Single Phase / 60 Hz.

**NOTES:**

1. Disconnect all power before servicing.
2. For supply connections use copper conductors only.
3. Not suitable on systems that exceed 150 volts to ground.
4. For replacement wires use conductors suitable for 105 °C
5. For ampacities and overcurrent protection, see unit rating plate.
6. Connect to 24 vac/4pva/class 2 circuit. See furnace/airhandler installation instructions for control circuit and optional relay/transformer kits.

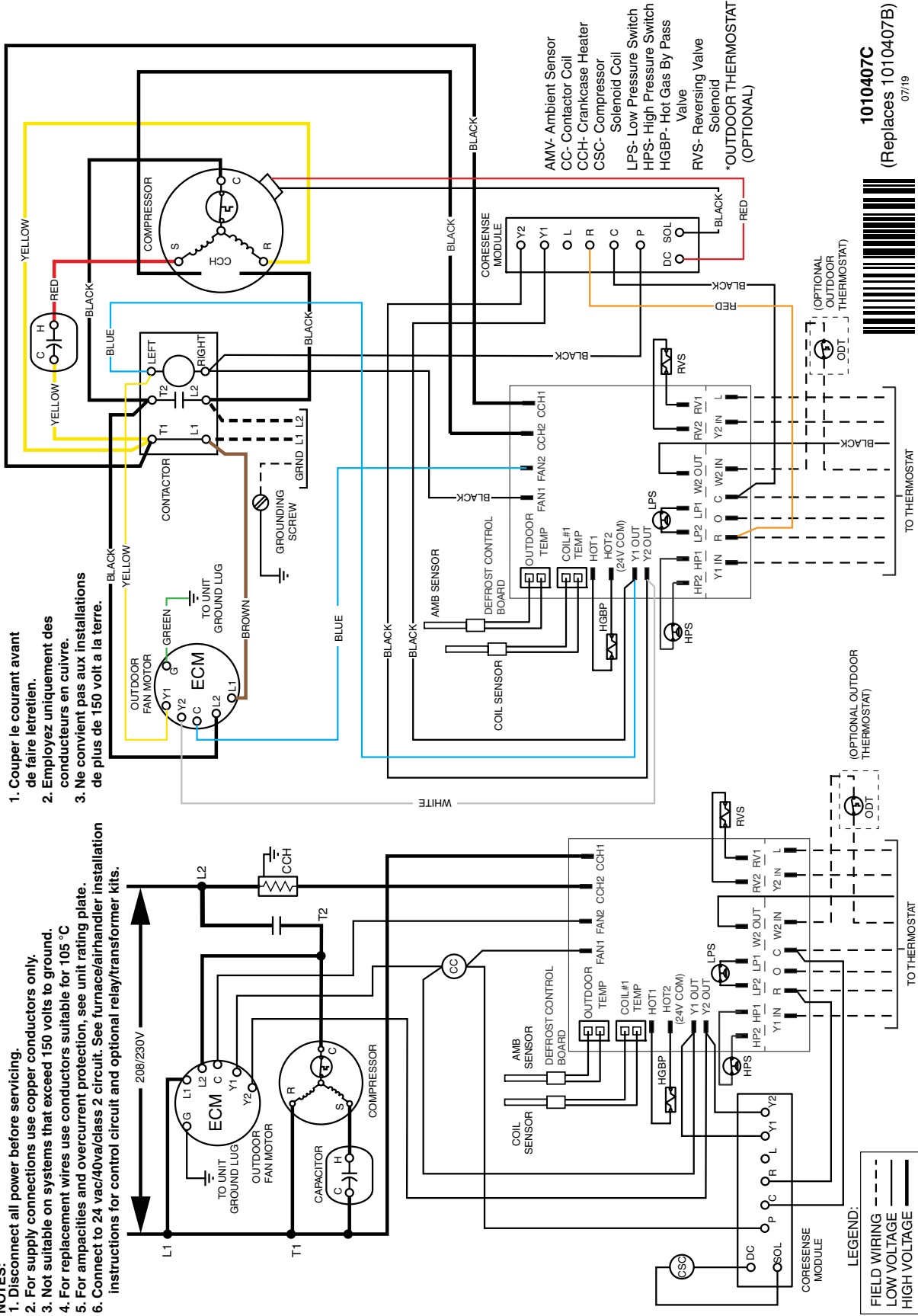

1. Couper le courant avant de faire le retretien.
2. Employez uniquement des conducteurs en cuivre.
3. Ne convient pas aux installations de plus de 150 volt a la terre.

1010407C  
 (Replaces 1010407B)  
 07/19

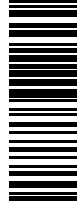

Figure 8. Wiring Diagram for 3, 4, & 5 Ton Units With CoreSense™

## CORESENSE™ TROUBLESHOOTING

STATUS LED	STATUS LED DESCRIPTION	STATUS LED TROUBLESHOOTING INFORMATION
Solid Green "RUN"	Module has power and operating normally	Supply voltage is present at module terminals
Solid Red "TRIP"	Thermostat demand signal Y is present, but the compressor is not running	<ol style="list-style-type: none"> <li>1. Compressor protector is open                             <ul style="list-style-type: none"> <li>• Check for high head pressure</li> <li>• Check compressor supply voltage</li> </ul> </li> <li>2. Outdoor unit power disconnect is open</li> <li>3. Compressor circuit breaker or fuse(s) is open</li> <li>4. Broken wire or connector is not making contact</li> <li>5. High pressure switch open if present in system</li> <li>6. Compressor contactor has failed open</li> </ol>
<b>ALERT Flash Codes</b>		
Yellow "ALERT" Flash Code 1	<b>LONG RUN TIME</b> Low Refrigerant Charge Compressor is running extremely long run cycles	<ol style="list-style-type: none"> <li>1. Low refrigerant charge</li> <li>2. Evaporator blower is not running                             <ul style="list-style-type: none"> <li>• Check blower relay coil and contacts</li> <li>• Check blower motor capacitor</li> <li>• Check blower motor for failure or blockage</li> <li>• Check evaporator blower wiring and connectors</li> <li>• Check indoor blower control board</li> <li>• Check thermostat wiring for open circuit</li> </ul> </li> <li>3. Evaporator coil is frozen                             <ul style="list-style-type: none"> <li>• Check for low suction pressure</li> <li>• Check for excessively low thermostat setting</li> <li>• Check evaporator airflow (coil blockages or return air filter)</li> <li>• Check ductwork or registers for blockage</li> </ul> </li> <li>4. Faulty metering device                             <ul style="list-style-type: none"> <li>• Check TXV bulb installation (size, location and contact)</li> <li>• Check if TXV/fixed orifice is stuck closed or defective</li> </ul> </li> <li>5. Liquid line restriction (filter drier blocked if present in system)</li> <li>6. Thermostat is malfunctioning                             <ul style="list-style-type: none"> <li>• Check thermostat sub-base or wiring for short circuit</li> <li>• Check thermostat installation (location, level)</li> </ul> </li> </ol>
Yellow "ALERT" Flash Code 2	<b>COMPRESSOR (PRESSURE) TRIP</b> High Refrigerant Charge Discharge pressure out of limits or compressor overloaded	<ol style="list-style-type: none"> <li>1. Condenser fan is not running                             <ul style="list-style-type: none"> <li>• Check fan capacitor</li> <li>• Check fan wiring and connectors</li> <li>• Check fan motor for failure or blockage</li> </ul> </li> <li>2. High head pressure                             <ul style="list-style-type: none"> <li>• Check high pressure switch if present in system</li> <li>• Check if system is overcharged with refrigerant</li> <li>• Check for non-condensable in system</li> </ul> </li> <li>3. Condenser coil poor air circulation (dirty, blocked, damaged)</li> <li>4. Return air duct has substantial leakage</li> </ol>
Yellow "ALERT" Flash Code 3	<b>PRESSURE SWITCH CYCLING</b> Compressor is running only briefly due to pressure switch cycling	<ol style="list-style-type: none"> <li>1. Time delay relay or control board defective</li> <li>2. If high pressure switch present go to Flash Code 2 information</li> </ol>
Yellow "ALERT" Flash Code 4	<b>LOCKED ROTOR</b>	<ol style="list-style-type: none"> <li>1. Run capacitor has failed</li> <li>2. Low line voltage (contact utility if voltage at disconnect is low)                             <ul style="list-style-type: none"> <li>• Check wiring connections</li> </ul> </li> <li>3. Excessive liquid refrigerant in compressor</li> <li>4. Compressor bearings are seized                             <ul style="list-style-type: none"> <li>• Measure compressor oil level</li> </ul> </li> </ol>
Yellow "ALERT" Flash Code 5	<b>COMPRESSOR (MODERATE RUN) TRIP</b>	<ol style="list-style-type: none"> <li>1. Evaporator blower is not running                             <ul style="list-style-type: none"> <li>• Check blower relay coil and contacts</li> <li>• Check blower motor capacitor</li> <li>• Check blower motor for failure or blockage</li> <li>• Check evaporator blower wiring and connectors</li> <li>• Check indoor blower control board</li> <li>• Check thermostat wiring for open circuit</li> </ul> </li> <li>2. Faulty metering device                             <ul style="list-style-type: none"> <li>• Check TXV bulb installation (size, location and contact)</li> <li>• Check if TXV/fixed orifice is stuck closed or defective</li> </ul> </li> <li>3. Condenser coil poor air circulation (dirty, blocked, damaged)</li> <li>4. Low refrigerant charge</li> </ol>

**Table 3. Coresense™ Diagnostics & LED Troubleshooting**

STATUS LED	STATUS LED DESCRIPTION	STATUS LED TROUBLESHOOTING INFORMATION
Yellow "ALERT" Flash Code 8	<b>WELDED CONTACTOR</b> Compressor always runs	1. Compressor contactor has failed closed 2. Thermostat demand signal not connected to module
Yellow "ALERT" Flash Code 9	<b>LOW SUPPLY VOLTAGE</b> Voltage below 18V	1. Control Circuit transformer is overloaded 2. Low line voltage (contact utility if voltage at disconnect is low)
<b>LOCKOUT Flash Codes</b>		
Red "LOCKOUT" Flash Code 2 Yellow Off	<b>COMPRESSOR (PRESSURE) TRIP</b> Compressor is locked out after 4 consecutive or 10 total compressor (pressure) trip events	1. Condenser fan is not running <ul style="list-style-type: none"> <li>• Check fan capacitor</li> <li>• Check fan wiring and connectors</li> <li>• Check fan motor for failure or blockage</li> </ul> 2. High head pressure <ul style="list-style-type: none"> <li>• Check high pressure switch if present in system</li> <li>• Check if system is overcharged with refrigerant</li> <li>• Check for non-condensable in system</li> </ul> 3. Condenser coil poor air circulation (dirty, blocked, damaged) 4. Return air duct has substantial leakage
Red "LOCKOUT" Flash Code 3 Yellow Off	<b>PRESSURE SWITCH CYCLING</b> Compressor is locked out after 4 consecutive or 10 total pressure cycling events	1. Time delay relay or control board defective 2. If high pressure switch present go to Flash Code 2 information
Red "LOCKOUT" Flash Code 4 Yellow Off	<b>LOCKED ROTOR</b> Compressor is locked out after 10 consecutive locked rotor events	1. Run capacitor has failed 2. Low line voltage (contact utility if voltage at disconnect is low) <ul style="list-style-type: none"> <li>• Check wiring connections</li> </ul> 3. Excessive liquid refrigerant in compressor 4. Compressor bearings are seized <ul style="list-style-type: none"> <li>• Measure compressor oil level</li> </ul>
Red "LOCKOUT" Flash Code 5 Yellow Off	<b>COMPRESSOR (MODERATE RUN) TRIP</b>	1. Evaporator blower is not running <ul style="list-style-type: none"> <li>• Check blower relay coil and contacts</li> <li>• Check blower motor capacitor</li> <li>• Check blower motor for failure or blockage</li> <li>• Check evaporator blower wiring and connectors</li> <li>• Check indoor blower control board</li> <li>• Check thermostat wiring for open circuit</li> </ul> 2. Faulty metering device <ul style="list-style-type: none"> <li>• Check TXV bulb installation (size, location and contact)</li> <li>• Check if TXV/fixed orifice is stuck closed or defective</li> </ul> 3. Condenser coil poor air circulation (dirty, blocked, damaged) 4. Low refrigerant charge
Red "LOCKOUT" Flash Code 6 Yellow Off	<b>OPEN START CIRCUIT</b> Current only in run circuit	1. Run capacitor has failed 2. Open circuit in compressor start wiring or connections <ul style="list-style-type: none"> <li>• Check wiring and connectors between supply and the compressor "S" terminal</li> </ul> 3. Compressor start winding is damaged <ul style="list-style-type: none"> <li>• Check compressor motor winding resistance</li> </ul>
Red "LOCKOUT" Flash Code 7 Yellow Off	<b>OPEN RUN CIRCUIT</b> Current only in start circuit	1. Open circuit in compressor run wiring or connections <ul style="list-style-type: none"> <li>• Check wiring and connectors between supply and the compressor "R" terminal. Confirm proper wire routing as shown in <a href="#">Figure 2, (page 5)</a>.</li> </ul> 2. Compressor run winding is damaged <ul style="list-style-type: none"> <li>• Check compressor motor winding resistance</li> </ul>
Red "LOCKOUT" Flash Code 10	<b>OVER CURRENT PROTECTION</b> Current to PROT is greater than 2A mps	1. Check for contactor shorted to ground 2. Check for mis-wiring to the PROT terminal

\* Flash code number corresponds to a number of LED flashes, followed by a pause and then repeated. Trip and alert LED's flashing at same time means control circuit voltage is too low for operation.

**Table 3. Coresense™ Diagnostics & LED Troubleshooting - Continued**





## INSTALLATION CHECKLIST

<b>INSTALLATION ADDRESS:</b>		
CITY:	STATE:	
UNIT MODEL #		
UNIT SERIAL #		
<b>INSTALLER NAME:</b>		
CITY:	STATE:	
Unit installed minimum clearances shown on <a href="#">page 3</a> ?	YES	NO
Has the owner's information been reviewed with the customer?	YES	NO
Has the literature package been left with the unit?	YES	NO

ELECTRICAL SYSTEM		
Electrical connections tight?	YES	NO
Line voltage polarity correct?	YES	NO
Rated Voltage:		
Max. deviation of voltage from avg. volts:		
Has the thermostat been calibrated?	YES	NO
Is the thermostat level?	YES	NO
Is the heat anticipator setting correct? (If Applicable)	YES	NO

### REPLACEMENT PARTS

Replacement parts are available through your distributor. Please have the complete model and serial number of the unit when ordering replacement parts.

REFRIGERATION SYSTEM		
Was unit given 24 hr warm up period for crankcase heaters?	YES	NO
Stage-1 Liquid Pressure (high side):		
Stage-1 Suction Pressure (low side):		

#### ELECTRICAL:

Capacitors	Temperature Limit Switches
Compressors	Thermostats
Contactors	Time Delay Relays
Pressure Switches	Transformers
Relays	

#### MOTORS:

Blower Motor  
Fan Motor

#### COMPONENTS:

Blower Assembly	Fan Grille
Cabinet Panels	Filter/Driers
Expansion Valves	

**We Encourage  
Professionalism**



Through Technician  
Certification by NATE



**Intertek**

