

INSTALLATION INSTRUCTIONS

*SH(1,2)QE4M1 - (R,S)P24K, (R,S)P30K, SP36K, SP42K, & SP48K (2, 2.5, 3, 3.5, & 4 TON) SERIES - SINGLE PHASE MODELS WITH QUICK CONNECT FITTINGS

IMPORTANT

ATTENTION INSTALLERS:

It is your responsibility to know this product better than your customer. This includes being able to install the product according to strict safety guidelines and instructing the customer on how to operate and maintain the equipment for the life of the product. Safety should always be the deciding factor when installing this product and using common sense plays an important role as well. Pay attention to all safety warnings and any other special notes highlighted in the manual. Improper installation of the unit or failure to follow safety warnings could result in serious injury, death, or property damage.

These instructions are primarily intended to assist qualified individuals experienced in the proper installation of this appliance. Some local codes require licensed installation/service personnel for this type of equipment. Please read all instructions carefully before starting the installation. Return these instructions to the customer's package for future reference.

DO NOT DESTROY. PLEASE READ CAREFULLY & KEEP IN A SAFE PLACE FOR FUTURE REFERENCE.

IMPORTANT SAFETY INFORMATION..... 2

HEAT PUMP INSTALLATION..... 3

 General Information 3

 Before You Install the Heat Pump..... 3

 Locating the Heat Pump 3

 Packaging Removal 3

 Ground Level 3

 Rooftop 3

 Connecting Refrigerant Tubing Between the Indoor & Outdoor Unit..... 3

ELECTRICAL WIRING 4

 Pre-Electrical Checklist 4

 Line Voltage 4

 Grounding 5

 Thermostat / Low Voltage Connections 5

START UP & ADJUSTMENTS 5

 Pre-Start Check List..... 5

 Start-Up Procedures 5

 Operating Temperatures 5

 Air Circulation - Indoor Blower..... 5

 Short Cycle Protection..... 5

 System Cooling 6

 System Heating 6

 Defrost Control Board Test Pins 6

HEAT PUMP MAINTENANCE..... 6

 Panel Removal..... 6

 Panel Installation..... 6

REFRIGERANT CHARGING 7

 Charging the Unit in AC mode 7

 If the outdoor temperature is 65 degrees F or higher: .. 7

 If the outdoor temperature is between 35 degrees F and 65 degrees F: 8

 If the outdoor temperature is below 35 degrees F:..... 8

WIRING DIAGRAMS..... 9

 Figure 6. Wiring Diagram for *SH2QE4M1RP 9

 Figure 7. Wiring Diagram for *SH2QE4M1SP 10

 Figure 8. Wiring Diagram for *SH1QE4M1SP With Low Pressure Switch..... 11

INSTALLATION CHECKLIST..... 12

REPLACEMENT PARTS..... 12

IMPORTANT SAFETY INFORMATION

INSTALLER: Please read all instructions before servicing this equipment. Pay attention to all safety warnings and any other special notes highlighted in the manual. Safety markings are used frequently throughout this manual to designate a degree or level of seriousness and should not be ignored. **WARNING** indicates a potentially hazardous situation that if not avoided, could result in personal injury or death. **CAUTION** indicates a potentially hazardous situation that if not avoided, may result in minor or moderate injury or property damage.

WARNING:

ELECTRICAL SHOCK, FIRE OR EXPLOSION HAZARD

Failure to follow safety warnings exactly could result in serious injury, death or property damage.

Improper servicing could result in dangerous operation, serious injury, death or property damage.

- **Before servicing, disconnect all electrical power to the unit.**
- **When servicing controls, label all wires prior to disconnecting. Reconnect wires correctly.**
- **Verify proper operation after servicing.**

WARNING:

This split system heat pumps is shipped charged with R410A refrigerant and ready for installation. If repairs make it necessary for evacuation and charging, it should only be attempted by qualified trained personnel thoroughly familiar with this equipment. Under no circumstances should the owner attempt to install and/or service this equipment. Failure to comply with this warning could result in property damage, personal injury, or death.

WARNING:

Unless noted otherwise in these instructions, only factory authorized parts or accessory kits may be used with this product. Improper installation, service, adjustment, or maintenance may cause explosion, fire, electrical shock or other hazardous conditions which may result in personal injury or property damage.

CAUTION:

This unit uses R-410A refrigerant. DO NOT use any other refrigerant in this unit. Use of another refrigerant may damage the unit.

WARNING:

The information listed below and the next page should be followed during the installation, service, and operation of this product. Failure to follow safety recommendations could result in possible damage to the equipment, serious personal injury or death.

- The installer must comply with all local codes and regulations which govern the installation of this type of equipment. Local codes and regulations take precedence over any recommendations contained in these instructions. Consult local building codes and the National Electrical Code (ANSI C1) for special installation requirements.
- All electrical wiring must be completed in accordance with local, state and national codes and regulations and with the National Electric Code (ANSI/NFPA 70) or in Canada the Canadian Electric Code Part 1 CSA C.22.1.
- This equipment contains liquid and gaseous refrigerant under high pressure. **DO NOT USE ANY PORTION OF THE CHARGE FOR PURGING OR LEAK TESTING.** Installation or servicing should only be performed by qualified trained personnel thoroughly familiar with this type equipment.
- Fully annealed, refrigerant grade copper tubing should be used when installing the system. Refrigerant suction line tubing should be fully insulated.
- Installation of equipment may require brazing operations. Installer must comply with safety codes and wear appropriate safety equipment (safety glasses, work gloves, fire extinguisher, etc.) when performing brazing operations.
- Follow all precautions in the literature, on tags, and on labels provided with the equipment. Read and thoroughly understand the instructions provided with the equipment prior to performing the installation and operational checkout of the equipment.
- This unit is designed for outdoor installations only and should be positioned as shown on [page 3](#).
- Use caution when handling this appliance or removing components. Personal injury can occur from sharp metal edges present in all sheet metal constructed equipment.

HEAT PUMP INSTALLATION

General Information

Split system heat pumps are designed only for outdoor rooftop or ground level installations. This unit has been tested for capacity and efficiency in accordance with AHRI Standards and will provide many years of safe and dependable comfort, providing it is properly installed and maintained. Abuse, improper use, and/or improper maintenance can shorten the life of the appliance and create unsafe hazards.

To achieve optimum performance and minimize equipment failure, it is recommended that periodic maintenance be performed on this unit. The ability to properly perform maintenance on this equipment requires certain mechanical skills and tools.

Refer to the Quick Reference Data sheet for additional electrical, charging and unit information.

Before You Install the Heat Pump

- ✓ The cooling load of the area to be conditioned needs to be calculated and a system of the proper capacity selected. It is recommended that the area to be conditioned be completely insulated and vapor sealed.
- ✓ Check the electrical supply and verify the power supply is adequate for unit operation. The system must be wired and provided with circuit protection in accordance with local building codes. If there is any question concerning the power supply, contact the local power company.
- ✓ The indoor section (air handler, furnace, etc) should be installed before routing the refrigerant tubing. Refer to the indoor unit's installation instructions for installation details.

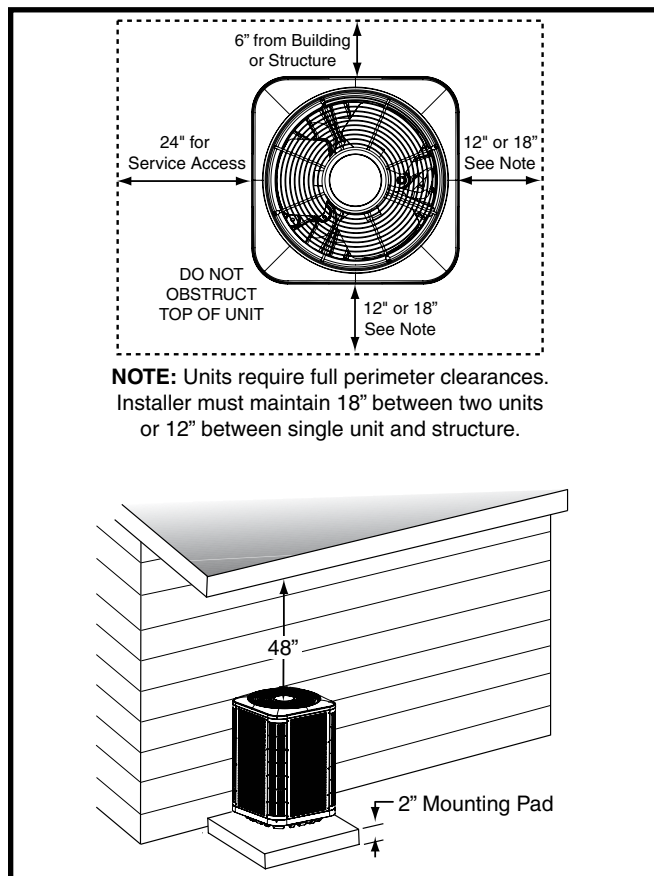

Figure 1. Clearance Requirements

- ✓ All units are securely packed at the time of shipment and upon arrival should be carefully inspected for damage prior to installing the equipment at the job site. Verify coil fins are straight. If necessary, comb fins to remove flattened or bent fins. Claims for damage (apparent or concealed) should be filed immediately with the carrier.
- ✓ Please consult your dealer for maintenance information and availability of maintenance contracts. Please read all instructions before installing the unit.

Locating the Heat Pump

- Survey the job site to determine the best location for mounting the outdoor unit.
- Overhead obstructions, poorly ventilated areas, and areas subject to accumulation of debris should be avoided. See [Figure 1](#).
- Sufficient clearance for unobstructed airflow through the outdoor coil must be maintained in order to achieve rated performance. See [Figure 1](#) for minimum clearances to obstructions.
- Consideration should be given to availability of electric power, service access, noise, and shade.

Packaging Removal

To prevent damage to the tubing connections, carefully remove the carton and user's manual from the equipment. Discard the shipping carton.

Ground Level

Ground level installations should be located according to local building codes or ordinances and these requirements:

- Clearances must be in accordance with those shown in [Figure 1](#).
- A suitable mounting pad must be provided and be separate from the building foundation. The pad needs to be level and strong enough to support the unit's weight. The slab height needs to be a minimum of 2" (5 cm) above grade and with adequate drainage. See [Figure 1](#).

Rooftop

- The method of mounting should be designed so that it does not overload roof structures or transmit noise to the interior of the structure. The roof must be structurally capable of handling the weight of the unit.
- Full perimeter support is required under the unit. Support must be made of weather resistant materials and installed prior to unit installation.
- The support must be built to raise the unit 6" above the roof.

Connecting Refrigerant Tubing Between the Indoor & Outdoor Unit

⚠ CAUTION:

When servicing, cover or seal openings to minimize the exposure of the refrigerant system to air to prevent accumulation of moisture and other contaminants.

After outdoor and indoor unit placement has been determined, route refrigerant tubing between the equipment in accordance with sound installation practices.

- Refrigerant tubing should be routed in a manner that minimizes the length of tubing and the number of bends in the tubing.

- Refrigerant tubing should be supported in a manner that the tubing will not vibrate or abrade during system operation.
 - Tubing should be kept clean of foreign debris during installation.
 - Every effort should be made by the installer to ensure that the field installed refrigerant containing components of the system have been installed in accordance with these instructions and sound installation practices to insure reliable system operation and longevity.
 - The maximum recommended interconnecting refrigerant line length is 75 feet, and the vertical elevation difference between the indoor and outdoor sections should not exceed 20 feet.
 - If precise forming of refrigerant lines is needed, a copper tubing bender is recommended. Avoid sharp bends and contact of the refrigerant lines with metal surfaces.
 - These units are equipped with single shot quick connect couplings. Together with the indoor section and line set, only four coupling connections are required to provide a 100% sealed system.
1. Route the suction line and liquid line between indoor and outdoor sections, remove protector caps and plugs.
 2. With a soft, dust-free cloth, carefully wipe clean all coupling threads and seals to remove any dust or material which could contaminate the refrigerant system.
 3. Using refrigerant oil, lightly lubricate the diaphragm, o-ring, and mating threads.
 4. Connect the couplings as follows:
 - a.) Line up the refrigerant line with the coil coupling and thread together by hand for 2-3 turns of the union nut (or until a sharp increase in torque is felt), to ensure proper thread mating.
 - b.) With the appropriate sized wrenches, tighten the union nut while preventing rotation of the female body with respect to the male half. Tighten the nut to the appropriate value in [Table 1](#).
 5. Using a marker, mark a line from the coupling union nut to the bulkhead then tighten an additional wrench flat (60°). Repeat for all couplings.
 6. Check the system for leaks

COUPLING SIZE	TORQUE	MALE COUPLING	FEMALE COUPLING NUT	FEMALE COUPLING BODY
3/8" (10mm)	10-12 Ft-Lbs (14-16 Nm)	3/4"	13/16"	5/8"
3/4" (19mm)	35-45 Ft-Lbs (47-61 Nm)	1-1/16"	1-5/16"	1"
7/8" (22mm)	35-45 Ft-Lbs (47-61 Nm)	1-1/8"	1-5/16"	1"

Table 1. Torque Values

ELECTRICAL WIRING

WARNING:

ELECTRICAL SHOCK, FIRE OR EXPLOSION HAZARD

Failure to follow safety warnings exactly could result in serious injury, death or property damage.

Improper servicing could result in dangerous operation, serious injury, death or property damage.

- **Before servicing, disconnect all electrical power to the unit.**
- **When servicing controls, label all wires prior to disconnecting. Reconnect wires correctly.**
- **Verify proper operation after servicing.**

- All electrical connections must be in compliance with all applicable local codes and ordinances, and with the current revision of the National Electric Code (ANSI/NFPA 70).
- For Canadian installations the electrical connections and grounding shall comply with the current Canadian Electrical Code (CSA C22.1 and/or local codes).

Pre-Electrical Checklist

- ✓ Verify that the voltage, frequency, and phase of the supply source match the specifications on the unit rating plate.
- ✓ Verify that the service provided by the utility is sufficient to handle the additional load imposed by this equipment. Refer to the unit wiring label for proper high and low voltage wiring.
- ✓ Verify factory wiring is in accordance with the unit wiring diagram. Inspect for loose connections. See [Figure 6 \(page 9\)](#), [Figure 7 \(page 10\)](#), & [Figure 8 \(page 11\)](#).

Line Voltage

- A wiring diagram is located on the inside cover of the electrical box of the outdoor unit. The installer should become familiar with the wiring diagram before making any electrical connections to the outdoor unit.
- **An electrical disconnect must be located within sight of and readily accessible to the unit.** This switch shall be capable of electrically de-energizing the outdoor unit.
- Line voltage to the unit should be supplied from a dedicated branch circuit containing the correct fuse or circuit breaker for the unit. Incoming field wiring and minimum size of electrical conductors and circuit protection must be in compliance with information listed on the outdoor unit data label. Any other wiring methods must be acceptable to authority having jurisdiction.
- The outdoor unit requires both power and control circuit electrical connections. Refer to the wiring diagrams for identification and location of outdoor unit field wiring interfaces. See [Figure 6 \(page 9\)](#), [Figure 7 \(page 10\)](#), & [Figure 8 \(page 11\)](#). Make all electrical connections in accordance with all applicable codes and ordinances.
- Overcurrent protection must be provided at the branch circuit distribution panel and sized as shown on the unit rating label and according to applicable local codes. See the unit rating plate for minimum circuit ampacity and maximum overcurrent protection limits.
- Provide power supply for the unit in accordance with the unit wiring diagram, and the unit rating plate. Connect the

line-voltage leads to the terminals on the contactor inside the control compartment.

- Use only copper wire for the line voltage power supply to this unit in strict accordance of the NEC (ANSI/NFPA 70), applicable local codes, and the instructions provided with the equipment.. Use proper code agency listed conduit and a conduit connector for connecting the supply wires to the unit. Use of rain tight conduit is recommended.
- 208/230 Volt units are shipped from the factory wired for 230 volt operation. For 208V operation, remove the lead from the transformer terminal marked 240V and connect it to the terminal marked 208V.
- Optional equipment requiring connection to the power or control circuits must be wired in strict accordance of the NEC (ANSI/NFPA 70), applicable local codes, and the instructions provided with the equipment.

Grounding

WARNING:

The unit cabinet must have an uninterrupted or unbroken electrical ground to minimize personal injury if an electrical fault should occur. Do not use gas piping as an electrical ground!

This unit must be electrically grounded in accordance with local codes or, in the absence of local codes, with the National Electrical Code (ANSI/NFPA 70) or the CSA C22.1 Electrical Code. Use the grounding lug provided in the control box for grounding the unit.

Thermostat / Low Voltage Connections

- Thermostat connections should be made in accordance with the instructions supplied with the thermostat and the indoor equipment. A typical installation with a heat pump thermostat and air handler is shown in [Figure 2](#).
- The outdoor unit is designed to operate from a 24 VAC Class II control circuit. The control circuit wiring must comply with the current provisions of the NEC (ANSI/NFPA 70) and with applicable local codes having jurisdiction.

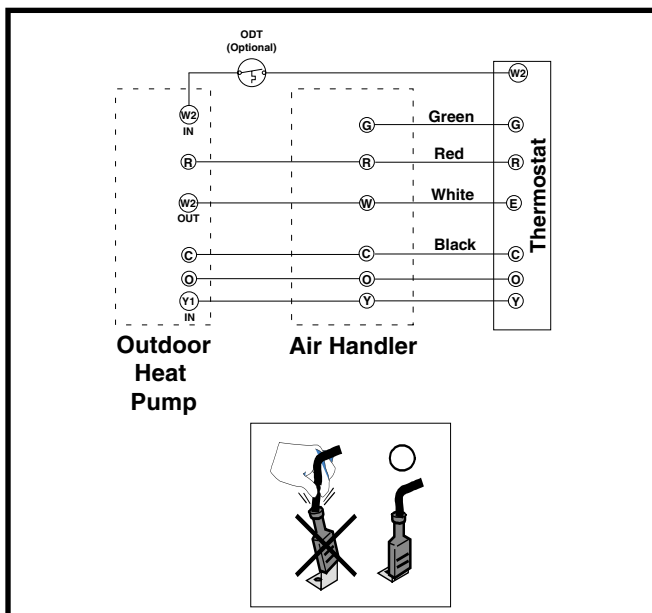

Figure 2. Typical Thermostat Connections

- The low voltage wires must be properly connected to the units low voltage terminal block.
- The thermostat should be mounted about 5 feet above the floor on an inside wall. DO NOT install the thermostat on an outside wall or any other location where its operation may be adversely affected by radiant heat from fireplaces, sunlight, or lighting fixtures, and convective heat from warm air registers or electrical appliances. Refer to the thermostat manufacturer's instruction sheet for detailed mounting and installation information.

START UP & ADJUSTMENTS

Pre-Start Check List

- ✓ Verify the unit is level and has sufficient clearances for unobstructed airflow.
- ✓ Verify the outdoor coil and top of the unit are free from obstructions and debris, and all equipment access/control panels are in place.
- ✓ Verify that the line voltage power leads are securely connected and the unit is properly grounded.
- ✓ Verify that the low voltage wires are securely connected to the correct leads on the low voltage terminal strip.
- ✓ Verify that the power supply branch circuit overcurrent protection is sized properly.
- ✓ Verify that the thermostat is wired correctly.

Start-Up Procedures

WARNING:

This unit is equipped with a crankcase heater. Allow 24 hours prior to continuing the start up procedures to allow for heating of the refrigerant compressor crankcase. Failure to comply may result in damage and could cause premature failure of the system. This warning should be followed at initial start up and any time the power has been removed for 12 hours or longer.

Operating Temperatures

This equipment has been designed to operate within the temperatures specified in [Table 2 \(page 6\)](#). Running the equipment in heating at higher than 70° F may require the use of a Heat Pump Mild Weather Control Kit or changing over to emergency or auxiliary heating.

Air Circulation - Indoor Blower

1. Set the thermostat system mode on OFF and the fan mode to ON.
2. Verify the blower runs continuously. Check the air delivery at the supply registers and adjust register openings for balanced air distribution. If insufficient air is detected, examine ductwork for leaks or obstructions.
3. Set the thermostat fan mode to AUTO and verify the blower stops running.

Short Cycle Protection

1. Set the thermostat system mode to COOL. Observe the temperature setting of the thermostat and gradually raise the set-point temperature until the unit de-energizes.
2. Immediately lower the set point temperature of the thermostat to its original setting and verify that the indoor blower is energized and outdoor unit remains de-energized.

COOLING		HEATING	
MIN (° F)	MAX (° F)	MIN (° F)	MAX (° F)
60	115	-10	70

Table 2. Heat Pump Operating Temperatures

STATUS INDICATOR	STATUS TYPE	DIAGNOSTIC DESCRIPTION
C1	Operating Status	Cooling, 1st Stage
H1	Operating Status	Heating, 1st Stage
SC	Operating Status	Anti Short Cycle Timer
DF	Operating Status	Defrost
--	Operating Status	Power on, no call for operation
P1	Fault	Pressure switch, low
P2	Fault	Pressure switch, high
P3	Fault	Temperature Sensor, Ambient
P4	Fault	Temperature Sensor, Coil
P5	Fault	Board
DF (FLASHING)	Input Error	Forced defrost - test short applied longer than 11 minutes

Table 3. Defrost Control Board Status Indicators

- After approximately 5 minutes, verify the outdoor unit energizes and the temperature of the discharge air is cooler than the room temperature.

System Cooling

- Set the thermostat's system mode to COOL and the fan mode to AUTO. Gradually lower the thermostat temperature setpoint below room temperature and verify the outdoor unit and indoor blower energize.
- Verify blower wheel is spinning in direction indicated by arrow. Feel the air being circulated by the indoor blower and verify that it is cooler than ambient temperature. Listen for any unusual noises. If unusual sounds occur, determine the source of the noise and correct as necessary.
- Verify HI and LO refrigerant pressures.
- Allow the system to operate for several minutes and then set the temperature selector above room temperature. Verify the fan and compressor cycle off with the thermostat.
NOTE: The blower should also stop unless fan switch is set to the ON position.

System Heating

- Set the thermostat's system mode to HEAT and the temperature mode to below room temperature.
- Verify the outdoor unit and indoor fan stop running. After 5 minutes, increase the temperature on the thermostat to it's maximum setting.
- Verify the outdoor unit and indoor blower energize. Feel the air being circulated by the indoor blower and verify that it is warmer than ambient temperature. Listen for any unusual noises. If unusual sounds occur, determine the source of the noise and correct as necessary.

Defrost Control Board Test Pins

- Placing a jumper between the test pins for less than 1 second will bypass the Anti-Short Cycle Timer.
- Placing a jumper between the test pins for more than 1 second will force the unit into a defrost cycle. As soon

as the jumper is removed, the defrost cycle will end as determined by the typical criteria.

- Verify the Status Indicator (on the control board) against the codes listed in [Table 3](#) to determine proper diagnostic description.

HEAT PUMP MAINTENANCE

WARNING:

To prevent electrical shock, personal injury, or death, disconnect all electrical power to the unit before performing any maintenance or service. The unit may have more than one electrical supply.

Proper maintenance is important to achieve optimum performance from the heat pump. The ability to properly perform maintenance on this equipment requires certain mechanical skills and tools. If you do not possess these skills, contact your dealer for maintenance. Consult your local dealer about the availability of maintenance contracts. Routine maintenance should include the following:

- Inspect and clean or replace air filters at the beginning of each heating and cooling season, or more frequently if needed.
- Inspect the outdoor coil at the beginning of each cooling season. Remove any debris. Clean the outdoor coil and louvers as necessary using a mild detergent and water. Rinse thoroughly with water.
- Inspect the electrical connections for tightness at the beginning of each heating and cooling season. Service as necessary.

CAUTION:

The unit should never be operated without a filter in the return air system. Replace disposable filters with the same type and size.

- Do not add additional oil to motors unequipped with oil tubes. The compressor is hermetically sealed at the factory and does not require lubrication.

Panel Removal

- Remove screws securing the panel.
- Slide the panel up towards the top pan in order to clear the bottom flange from the base pan. See [Figure 3 \(page 7\)](#).
- Swing the bottom of the panel out and pull the panel down to remove it from the unit.

Panel Installation

- Insert the top corners of side panel flanges into the corner post channels as shown in Detail A in [Figure 4 \(page 7\)](#).
- Slide the panel up into the top pan. (You may need to push on the center of the panel at the top in order to clear the top pan edge).
- Swing the panel in and push down until the panel is resting on the top edge of the base pan wall as shown in Detail B.
- Install screws into the panel to secure it to the unit.

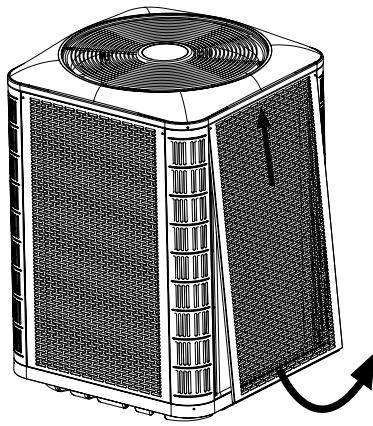

Figure 3. Panel Removal

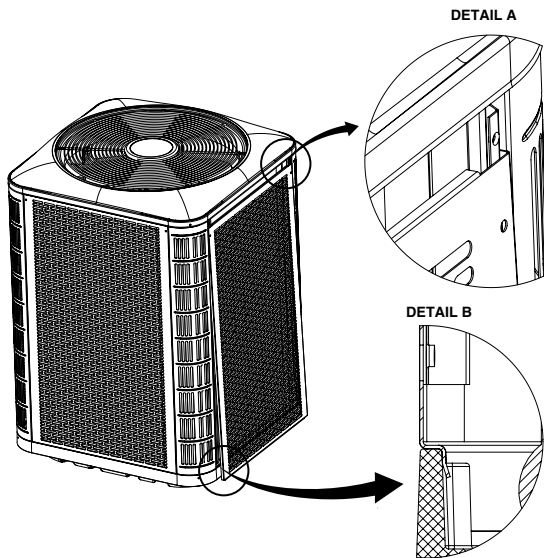

Figure 4. Panel Installation

REFRIGERANT CHARGING

⚠ WARNING:

SH(1,2)QE4M split system heat pumps are shipped charged with R410A refrigerant and ready for installation. If repairs make it necessary for evacuation and charging, it should only be attempted by qualified trained personnel thoroughly familiar with this equipment. Under no circumstances should the owner attempt to install and/or service this equipment. Failure to comply with this warning could result in property damage, personal injury, or death.

- After refrigerant line connections are completed, it is required that you leak check and evacuate the indoor section and all line connections (using proper methods) before finalizing the full system refrigerant charge.
- To achieve rated capacity and efficiency, the compressor must be exposed to refrigerant for at least 24 hours prior to running and then the compressor must be run for a minimum of 12 hours.

- Refer to the unit's Quick Reference Data sheet to determine if additional refrigerant will need to be weighed-in to attain the base refrigerant amount for the system match that is being installed. Please note that the charge additions provided in the QRD are estimates based on test data and should only be used as a starting point. Complete the steps in the charging procedure to obtain the final system charge.
- Use of SH(1,2)QE4M outdoor units with non-AHRI listed indoor coils are not recommended and deviations from rated airflows or non-listed combinations may require modification to the expansion device and refrigerant charging procedures for proper and efficient system operation.
- The refrigerant charge can be checked and adjusted through the service ports provided external to the outdoor unit. Use only gage line sets which have a "Schrader" depression device present to actuate the valve. A common suction port for heating mode charging is included and located on the compressor access panel above the outdoor unit service valves.
- A high-pressure switch is factory-installed and located in the compressor discharge line internal to the outdoor unit. The switch is designed to de-energize the system when very high pressures occur during abnormal conditions. Under normal conditions, the switch is closed. If the discharge pressure rises above 575 psig, then the switch will open and de-energize the outdoor unit. The switch will close again once the liquid pressure decreases to 460 psig. Please note that the switch interrupts the thermostat inputs to the unit. When the switch opens and then closes, there will be a 5 minute short cycling delay before the outdoor unit will energize.
- A low-pressure switch is factory installed (certain models) and located internally on the suction line of the outdoor unit. The switch is designed to protect the compressor from a loss of charge by interrupting the thermostat inputs to the unit. If the suction pressure falls below 20 psig, the switch will open and de-energize the outdoor unit. The switch will close again when the suction pressure increases above 35 psig. When the switch opens and then closes, there is a 3 minute short cycling delay before the outdoor unit will energize. Under normal conditions the switch is closed.

NOTE: Quick connect heat pumps are shipped fully charged with R410A refrigerant and ready for installation and in normal circumstances no refrigerant charging is required. The instructions below are for use if refrigerant charging is necessary during later service calls.

Charging the Unit in AC mode

If the outdoor temperature is 65 degrees F or higher:

After completing the refrigerant line connections, leak checking the system, and evacuating the indoor section and all line connections (using proper methods), perform the following steps:

1. Determine the recommended charge addition (if applicable) for the system being installed. This information is in the unit's QRD (Quick Reference Data sheet).
2. Calculate the amount of additional refrigerant needed for the line set length of the actual installation. This information is on the first page of the unit's QRD (Quick Reference Data sheet).
3. Weigh in the additional charge amounts determined by step 1 and 2 above.

4. Adjust the charge to match the superheat (for fixed orifice systems) or subcooling (for TXV systems). There are three different resources for doing this:

- a.) The chargecalculator.com website. This will walk you through the charging process step by step.
- b.) The charging tables on the inside of the outdoor unit's electrical box cover panel. These tables provide superheat targets for fixed orifice systems and subcooling targets for TXV systems. The system should be charged so that the measured superheat/subcooling are within 1 degree F of the target listed in the table.

For fixed orifice systems:

- If your measured superheat at the suction valve is **LESS THAN** the recommended superheat value in the table then **REMOVE** refrigerant.
- If your measured superheat at the suction valve is **GREATER THAN** the recommended superheat value in the table then **ADD** refrigerant.

For TXV systems:

- If your measured subcooling at the liquid valve is **LESS THAN** the recommended subcooling value in the table then **ADD** refrigerant.
- If your measured subcooling at the liquid valve is **GREATER THAN** the recommended subcooling value in the table then **REMOVE** refrigerant.

- c.) The charging tables in the Supplemental Charging Information, can be found online in the literature library. The tables can also be accessed by scanning the QR code on the unit's electrical panel. The pressures listed in these tables are for reference only and are to be used in troubleshooting a system. **The system should be charged to match the superheat or subcooling targets as previously noted and not to match the system pressures.** Follow the same procedure described in 4b above.

If the outdoor temperature is between 35 degrees F and 65 degrees F:

After completing the refrigerant line connections, leak checking the system, and evacuating the indoor section and all line connections (using proper methods), perform the following steps:

1. Determine the recommended charge addition (if applicable) for the system being installed. This information is in the unit's QRD (Quick Reference Data sheet).
2. Calculate the amount of additional refrigerant needed for the line set length of the actual installation. This information is on the first page of the unit's QRD (Quick Reference Data sheet).
3. Weigh in the additional charge amounts determined by step 1 and 2 above.
4. Block off the discharge of the outdoor fan. **NOTE:** One half of the unit should be covered corner to corner as shown in [Figure 5](#).
5. With the unit in cooling mode, Adjust the charge to match the superheat (for fixed orifice systems) or subcooling (for TXV systems). There are two different resources for doing this:
 - a.) The chargecalculator.com website. This will walk you through the charging process step by step.
 - b.) The low ambient charging tables on the inside of the outdoor unit's electrical box cover panel. These

tables provide superheat targets for fixed orifice systems and subcooling targets for TXV systems. The system should be charged so that the measured superheat/subcooling are within 1 degree F of the target listed in the table.

For fixed orifice systems:

- If your measured superheat at the suction valve is **LESS THAN** the recommended superheat value in the table then **REMOVE** refrigerant.
- If your measured superheat at the suction valve is **GREATER THAN** the recommended superheat value in the table then **ADD** refrigerant.

For TXV systems:

- If your measured subcooling at the liquid valve is **LESS THAN** the recommended subcooling value in the table then **ADD** refrigerant.
- If your measured subcooling at the liquid valve is **GREATER THAN** the recommended subcooling value in the table then **REMOVE** refrigerant

If the outdoor temperature is below 35 degrees F:

After completing the refrigerant line connections, leak checking the system, and evacuating the indoor section and all line connections (using proper methods), perform the following steps:

1. Determine the recommended charge addition (if applicable) for the system being installed. This information is in the unit's QRD (Quick Reference Data sheet).
2. Calculate the amount of additional refrigerant needed for the line set length of the actual installation. This information is on the first page of the unit's QRD (Quick Reference Data sheet).
3. Weigh in the additional charge amounts determined by step 1 and 2 above.
4. Return to the system when the outdoor temperature is 35 degrees F or higher and follow the steps defined in step 4 of the "If the outdoor temperature is between 35 degrees and 65 degrees F" or "If the outdoor temperature is 65 degree F or higher" sections above as applicable.

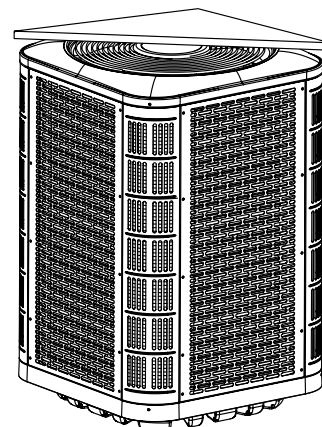

NOTE: One half of the unit should be covered corner to corner.

Figure 5. Blocked Off Outdoor Fan Discharge

WIRING DIAGRAMS

WIRING DIAGRAM

Split System Heat Pump (Outdoor Section)

Single Phase

NOTES:

1. Disconnect all power before servicing.
2. For supply connections use copper conductors only.
3. Not suitable on systems that exceed 150 volts to ground
4. For replacement wires use conductors suitable for 105° C.
5. For ampacities and overcurrent protection, see unit rating plate.
6. Connect to 24 vac/40va/class 2 circuit. See furnace/air handler installation instructions for control circuit and optional relay/transformer kits.

1. Couper le courant avant de faire letretien.
2. Employez uniquement des conducteurs en cuivre.
3. Ne convient pas aux installations de plus de 150 volt a la terre.

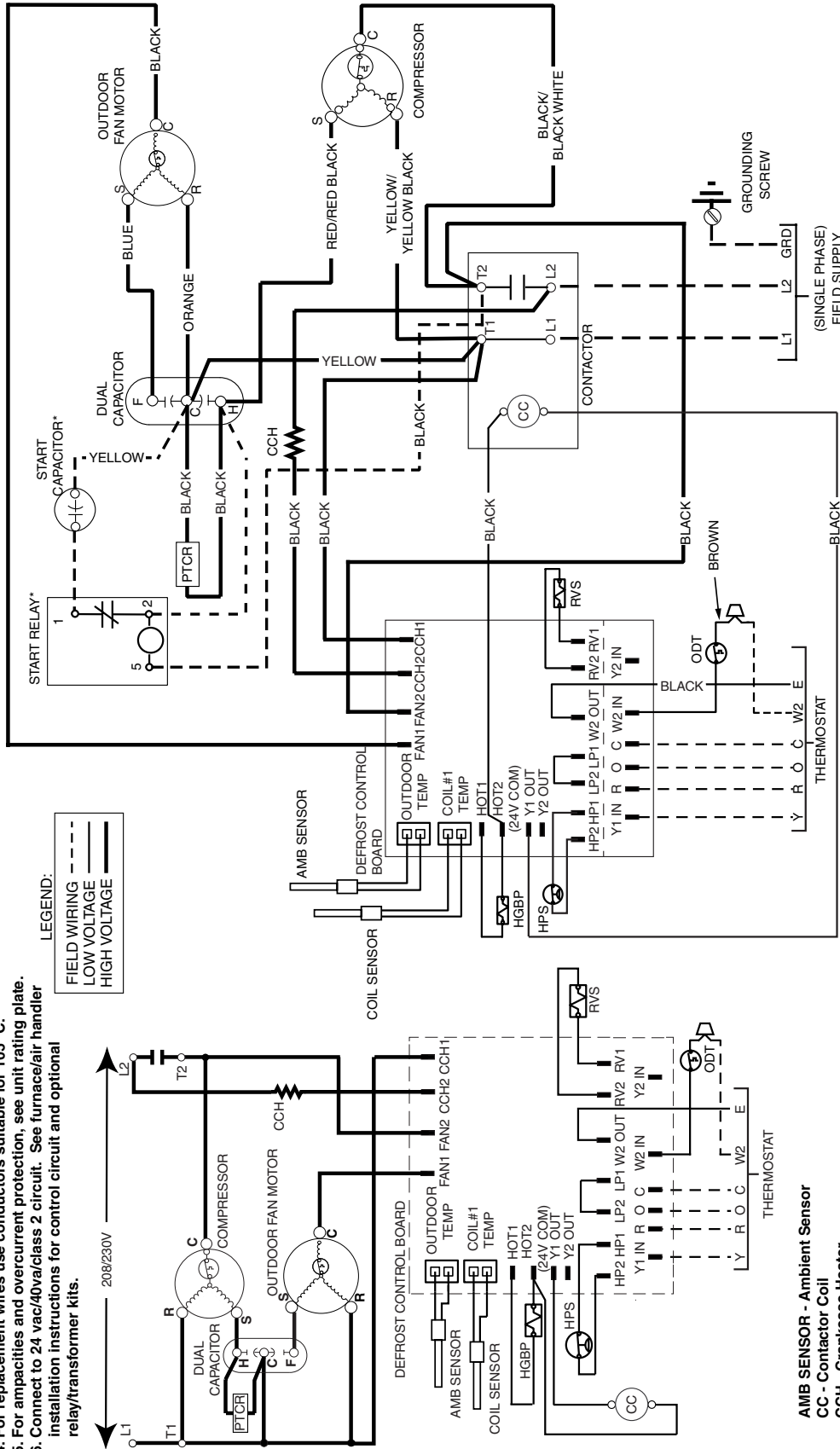

10252180
10/18

Figure 6. Wiring Diagram for *SH2QE4M1RP

WIRING DIAGRAM

Split System Heat Pump (Outdoor Section)

- NOTES:**
1. Disconnect all power before servicing.
 2. For supply connections use copper conductors only.
 3. Not suitable on systems that exceed 150 volts to ground
 4. For replacement wires use conductors suitable for 105° C.
 5. For ampacities and overcurrent protection, see unit rating plate.
 6. Connect to 24 vac/40va/class 2 circuit. See furnace/air handler installation instructions for control circuit and optional relay/transformer kits.

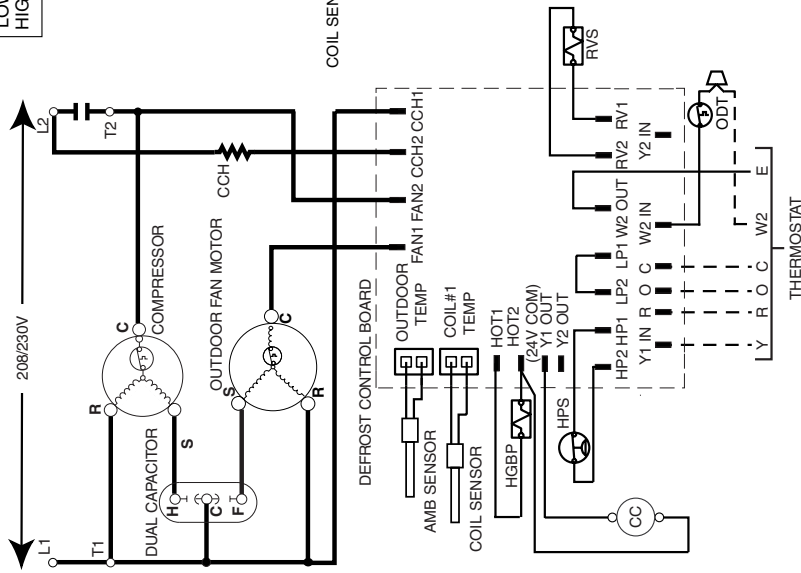

- AMB SENSOR - Ambient Sensor
- CC - Contactor Coil
- CCH - Crankcase Heater
- HPS - High Pressure Switch
- HGBPV - Hot Gas By Pass Valve
- RVS - Reversing Valve Solenoid
- ODT - Outdoor Thermostat
- * HARD START KIT (OPTIONAL)

Single Phase

1. Couper le courant avant de faire le retien.
2. Employez uniquement des conducteurs en cuivre.
3. Ne convient pas aux installations de plus de 150 volt a la terre.

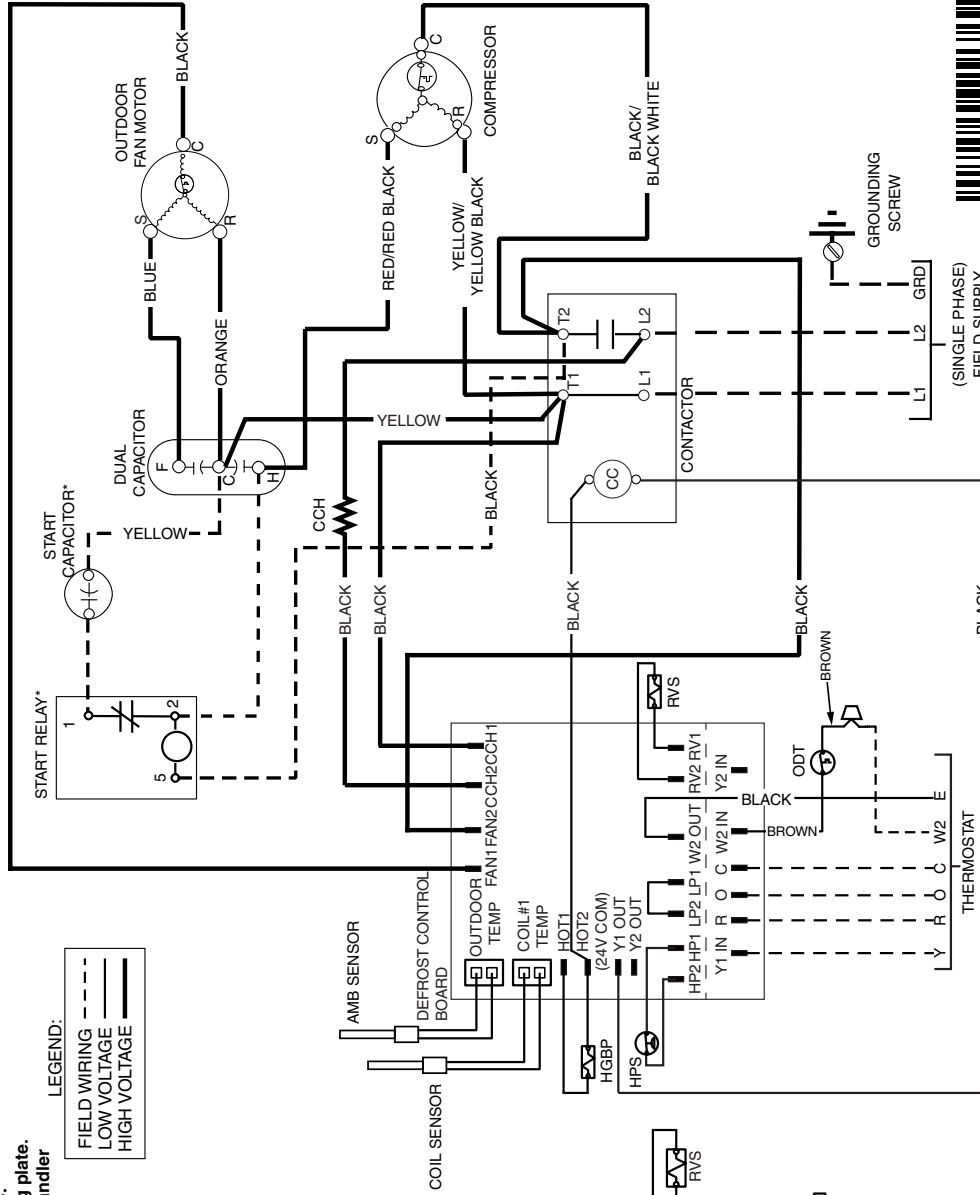

10214360
(New)
03/18

Figure 7. Wiring Diagram for *SH2QE4M1SP

WIRING DIAGRAM

Split System Heat Pump (Outdoor Section)

- NOTES:**
1. Disconnect all power before servicing.
 2. For supply connections use copper conductors only.
 3. Not suitable on systems that exceed 150 volts to ground
 4. For replacement wires use conductors suitable for 105° C.
 5. For ampacities and overcurrent protection, see unit rating plate.
 6. Connect to 24 vac/40va/class 2 circuit. See furnace/air handler relay/transformer kits.

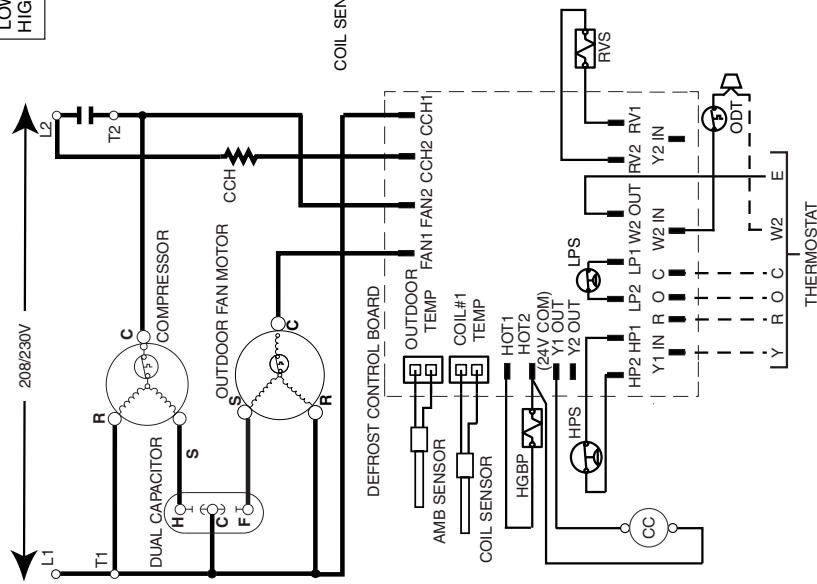

- AMB SENSOR - Ambient Sensor
- CC - Contactor Coil
- CCH - Crankcase Heater
- HPS - High Pressure Switch
- HGBP - Hot Gas By Pass Valve
- RVS - Reversing Valve Solenoid
- ODT - Outdoor Thermostat
- * HARD START KIT (OPTIONAL)
- LPS - Low Pressure Switch

Single Phase

1. Couper le courant avant de faire leretien.
2. Employez uniquement des conducteurs en cuivre.
3. Ne convient pas aux installations de plus de 150 volt a la terre.

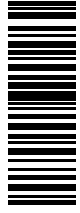
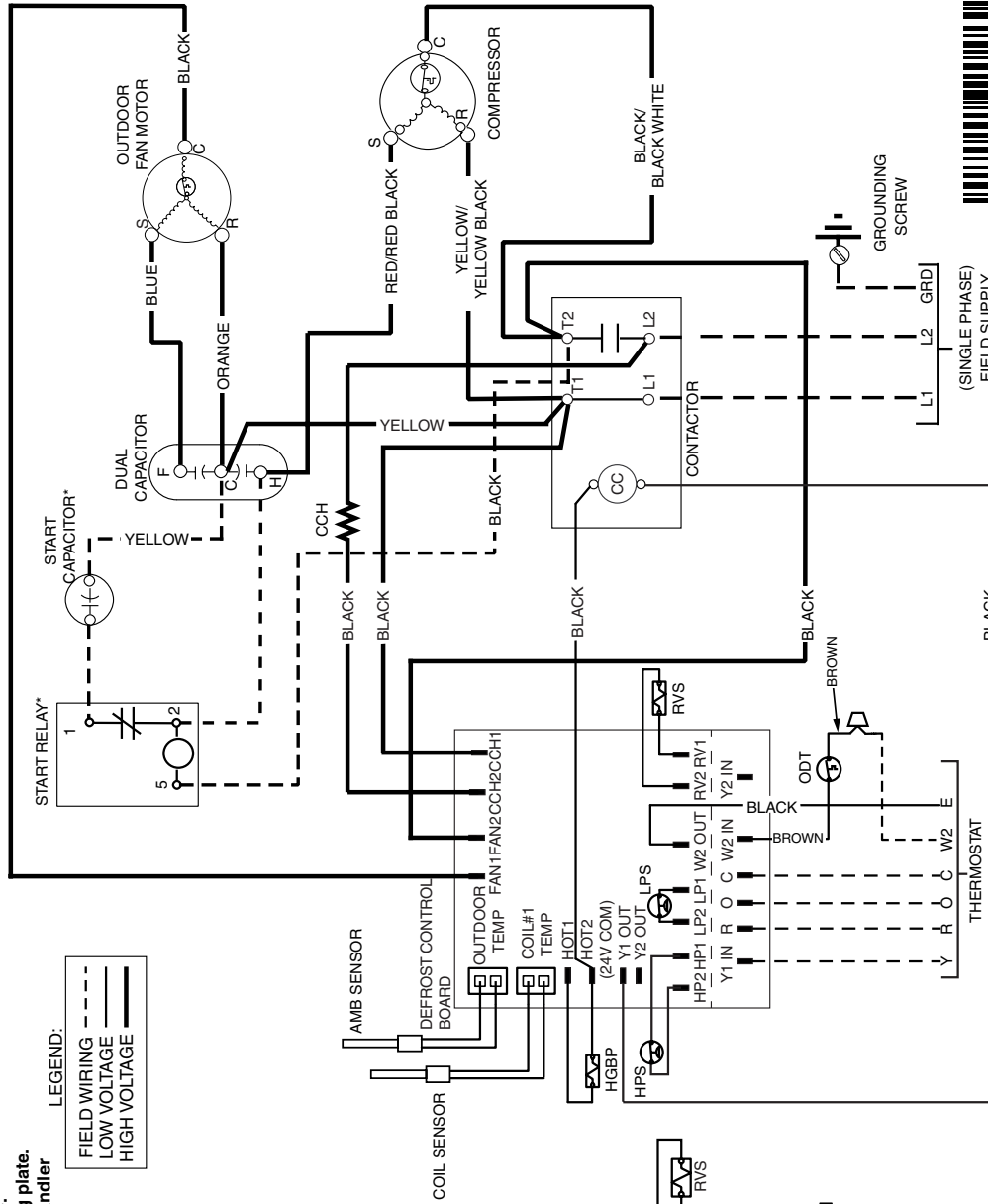

10252920
(New)
01/19

Figure 8. Wiring Diagram for *SH1QE4M1SP With Low Pressure Switch

INSTALLATION CHECKLIST

INSTALLATION ADDRESS:		
CITY:	STATE:	
UNIT MODEL #:		
UNIT SERIAL #:		
INSTALLER NAME:		
CITY:	STATE:	
Unit installed minimum clearances shown on page 3 ?	YES	NO
Has the owner's information been reviewed with the customer?	YES	NO
Has the literature package been left with the unit?	YES	NO

REFRIGERATION SYSTEM		
Was unit given 24 hr warm up period for crankcase heaters?	YES	NO
Stage-1 Liquid Pressure (High Side):		
Stage-1 Suction Pressure (Low Side):		

ELECTRICAL SYSTEM		
Electrical connections tight?	YES	NO
Line voltage polarity correct?	YES	NO
Rated Voltage:		
Max. deviation of voltage from avg. volts:		
Has the thermostat been calibrated?	YES	NO
Is the thermostat level?	YES	NO
Is the heat anticipator setting correct? (If Applicable)	YES	NO

REPLACEMENT PARTS

Replacement parts are available through your distributor. Please have the complete model and serial number of the unit when ordering replacement parts.

ELECTRICAL:

- | | |
|-------------------|----------------------------|
| Capacitors | Temperature Limit Switches |
| Compressors | Thermostats |
| Contactors | Time Delay Relays |
| Pressure Switches | Transformers |
| Relays | |

MOTORS:

- Blower Motor
- Fan Motor

COMPONENTS:

- | | |
|------------------|---------------|
| Blower Assembly | Fan Grille |
| Cabinet Panels | Filter/Driers |
| Expansion Valves | |

