

INSTALLATION INSTRUCTIONS

2, 2.5, 3, 3.5, 4, & 5 Ton, 13 SEER, Single Phase Models With Quick Connect Couplings

IMPORTANT SAFETY INFORMATION 2

AIR CONDITIONER INSTALLATION 3

General Information 3

Before You Install this Unit..... 3

Locating the Air conditioner..... 3

Packaging Removal 3

Ground Level..... 3

Roof Mount..... 3

Connecting Refrigerant Tubing Between the Indoor & Outdoor Unit 4

ELECTRICAL WIRING..... 4

Pre - Electrical Checklist 4

Line Voltage..... 4

Thermostat / Low Voltage Connections..... 5

Grounding 5

STARTUP & ADJUSTMENTS 6

Pre - Start Checklist 6

Start-up Procedures..... 6

Air Circulation - Indoor Blower 6

System Cooling..... 6

System Heating..... 6

REFRIGERANT CHARGING 6

Charging the Unit in AC Mode 6

AIR CONDITIONER MAINTENANCE..... 7

COMPONENT FUNCTIONS 7

REPLACEMENT PARTS..... 7

CHARGING CHARTS & TABLES..... 8

Table 4. Charging Table for - 2 Ton Units..... 9

Table 5. Charging Table for - 2.5 Ton Units..... 9

Table 6. Charging Table for - 3 Ton Units..... 9

Figure 2. Charging Chart for - 2 Ton Units 10

Figure 3. Charging Chart for 2.5 Ton Units..... 10

Figure 4. Charging Chart for 3 Ton Units..... 11

Figure 5. Charging Chart for 3.5 Ton Units..... 11

Figure 6. Charging Chart for 4 Ton Units..... 12

Figure 7. Charging Chart for 5 Ton Units..... 12

WIRING DIAGRAMS..... 13

Figure 8. Wiring Diagram - 2 - 3 Ton Units 13

Figure 9. Wiring Diagram - 3.5 - 5 Ton Units 14

INSTALL. / PERFORMANCE CHECKLIST 16

IMPORTANT

ATTENTION INSTALLERS

Please read all instructions before servicing this equipment. Pay attention to all safety warnings and any other special notes highlighted in the manual. Safety markings are used frequently throughout this manual to designate a degree or level of seriousness and should not be ignored.

WARNING indicates a potentially hazardous situation that if not avoided, could result in personal injury or death.

CAUTION indicates a potentially hazardous situation that if not avoided, may result in minor or moderate injury or property damage.

It is your responsibility to know this product better than your customer. This includes being able to install the product according to strict safety guidelines and instructing the customer on how to operate and maintain the equipment for the life of the product. Safety should always be the deciding factor when installing this product and using common sense plays an important role as well. Pay attention to all safety warnings and any other special notes highlighted in the manual. Improper installation of the furnace or failure to follow safety warnings could result in serious injury, death, or property damage.

These instructions are primarily intended to assist qualified individuals experienced in the proper installation of this appliance. Some local codes require licensed installation/service personnel for this type of equipment. Please read all instructions carefully before starting the installation. Return these instructions to the customer's package for future reference.

DO NOT DESTROY. PLEASE READ CAREFULLY AND KEEP IN A SAFE PLACE FOR FUTURE REFERENCE.

IMPORTANT SAFETY INFORMATION

WARNING:

Shut off all electrical power to the unit before performing any maintenance or service on the system. Failure to comply may result in personal injury or death.

WARNING:

Unless noted otherwise in these instructions, only factory authorized parts or accessory kits may be used with this product. Improper installation, service, adjustment, or maintenance may cause explosion, fire, electrical shock or other hazardous conditions which may result in personal injury or property damage

WARNING:

S6QD Split system air conditioners are shipped fully charged with R410A refrigerant and ready for installation. When system is installed according to these instructions, no refrigerant charging is required. If repairs make it necessary for evacuation and charging, it should only be attempted by qualified trained personnel thoroughly familiar with this equipment. Under no circumstances should the owner attempt to install and/or service this equipment. Failure to comply with this warning could result in property damage, personal injury, or death.

CAUTION:

This unit uses R-410A refrigerant. **DO NOT** use any other refrigerant in this unit. Use of another refrigerant will damage the unit.

PROPOSITION 65 WARNING:

WARNING: This product contains chemicals known to the state of California to cause cancer.

WARNING: This product contains chemicals known to the state of California to cause birth defects or other reproductive harm.

WARNING:

The information listed below must be followed during the installation, service, and operation of this unit. Unqualified individuals should not attempt to interpret these instructions or install this equipment. Failure to follow safety recommendations could result in possible damage to the equipment, serious personal injury or death.

- The installer must comply with all local codes and regulations which govern the installation of this type of equipment. Local codes and regulations take precedence over any recommendations contained in these instructions. Consult local building codes and the National Electrical Code (ANSI CI) for special installation requirements.
- All electrical wiring must be completed in accordance with local, state and national codes and regulations and with the National Electric Code (ANSI/NFPA 70) or in Canada the Canadian Electric Code Part 1 CSA C.22.1.
- This equipment contains liquid and gaseous refrigerant under high pressure. **DO NOT USE ANY PORTION OF THE CHARGE FOR PURGING OR LEAK TESTING.** Installation or servicing should only be performed by qualified trained personnel thoroughly familiar with this type equipment.
- Refrigerant suction line tubing should be fully insulated.
- Installation of equipment may require brazing operations. Installer must comply with safety codes and wear appropriate safety equipment (safety glasses, work gloves, fire extinguisher, etc.) when performing brazing operations.
- Follow all precautions in the literature, on tags, and on labels provided with the equipment. Read and thoroughly understand the instructions provided with the equipment prior to performing the installation and operational checkout of the equipment.
- Refrigerant and electrical line should be routed through suitably waterproofed openings to prevent water from leaking into the structure.

AIR CONDITIONER INSTALLATION

General Information

The S6QD series air conditioner is designed only for outdoor rooftop or ground level installations. This unit has been tested for capacity and efficiency in accordance with AHRI Standards and will provide many years of safe and dependable comfort, providing it is properly installed and maintained. Abuse, improper use, and/or improper maintenance can shorten the life of the appliance and create unsafe hazards.

To achieve optimum performance and minimize equipment failure, it is recommended that periodic maintenance be performed on this unit. The ability to properly perform maintenance on this equipment requires certain mechanical skills and tools.

Before You Install this Unit

- ✓ The cooling load of the area to be conditioned must be calculated and a system of the proper capacity selected. It is recommended that the area to be conditioned be completely insulated and vapor sealed.
- ✓ Check the electrical supply and verify the power supply is adequate for unit operation. The system must be wired and provided with circuit protection in accordance with local building codes. If there is any question concerning the power supply, contact the local power company.
- ✓ The indoor section (air handler, furnace, etc) should be installed before routing the refrigerant tubing. Refer to the indoor unit's installation instructions for installation details.
- ✓ All units are securely packed at the time of shipment and upon arrival should be carefully inspected for damage prior to installing the equipment at the job site. Verify coil fins are straight. Claims for damage (apparent or concealed) should be filed immediately with the carrier.
- ✓ Please consult your dealer for maintenance information and availability of maintenance contracts. Please read all instructions before installing the unit.

Locating the Air Conditioner

- Survey the job site to determine the best location for mounting the outdoor unit.
- The outdoor unit should be installed no closer than 18 inches from the outside walls of the facility and in an area free from overhead obstructions to ensure unrestricted airflow through the outdoor unit.
- Sufficient clearance for unobstructed airflow through the outdoor coil must be maintained in order to achieve rated performance.
- Overhead obstructions (Figure 1), poorly ventilated areas, and areas subject to accumulation of debris should be avoided.
- Consideration should be given to availability of electric power, service access, noise, and shade.

Packaging Removal

NOTE: To prevent damage to the tubing connections, carefully remove the carton and user's manual from the equipment. Discard the shipping carton.

Ground Level

Ground level installations must be located according to local building codes or ordinances and these requirements:

- Clearances must be in accordance with those shown in Figure 1.
- A suitable mounting pad must be provided and separate from the building foundation. The pad must be level and strong enough to support the weight of the unit. The slab height must be a minimum of 2" (5 cm) above grade and with adequate drainage. See Figure 1.

Roof Mount

- The method of mounting should be designed so that it does not overload roof structures or transmit noise to the interior of the structure. The roof must be structurally capable of handling the weight of the unit.
- Full perimeter support is required under the unit. Support must be made of weather resistant materials and installed prior to unit installation.
- The support must be built to raise the unit 6" above the roof.

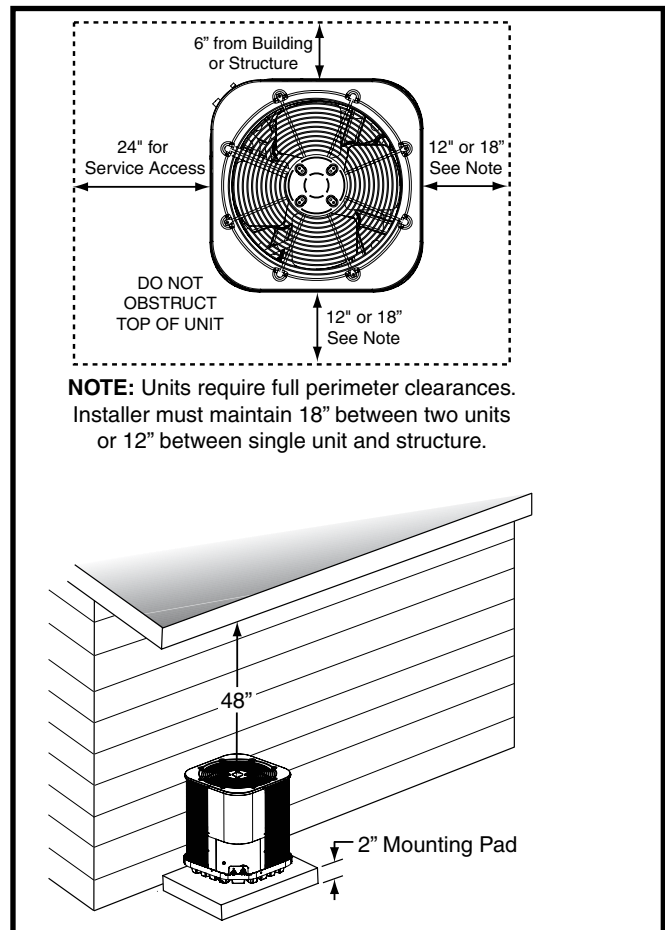

Figure 1. Clearance Requirements

Connecting Refrigerant Tubing Between the Indoor & Outdoor Unit

CAUTION:

When servicing, cover or seal openings to minimize the exposure of the refrigerant system to air to prevent accumulation of moisture and other contaminants.

After outdoor and indoor unit placement has been determined, route refrigerant tubing between the equipment in accordance with sound installation practices.

- Refrigerant tubing should be routed in a manner that minimizes the length of tubing and the number of bends in the tubing. If precise forming of refrigerant lines is required, a copper tubing bender is recommended. Avoid sharp bends and contact of the refrigerant lines with metal surfaces.
- Refrigerant tubing should be supported in a manner that the tubing will not vibrate or abrade during system operation.
- Tubing should be kept clean of foreign debris during installation.
- A filter dryer is factory installed in the outdoor unit.
- Every effort should be made by the installer to ensure that the field installed refrigerant containing components of the system have been installed in accordance with these instructions and sound installation practices to insure reliable system operation and longevity.
- The maximum recommended interconnecting refrigerant line lengths is 75 ft. and the vertical elevation difference between the indoor and outdoor sections should not exceed 20 ft.
- Optional equipment such as liquid line solenoid valves, low ambient, etc., should be installed in strict accordance with the manufacturer's installation instructions.
- These units are equipped with single shot quick connect couplings. Together with the indoor section and line set, only four coupling connections are required to provide a 100% sealed system.
 - Route the suction line and liquid line between indoor and outdoor sections, remove protector caps and plugs
 - Lubricate entire surface of the diaphragm O-ring and threads of the male coupling using the lubricant supplied with the line set and a small brush.
 - Make sure the coupling halves are held in proper alignment with each other prior to starting the threads of female coupling nut onto the male half. Thread coupling halves together by hand until a definite resistance is felt.
 - Using a marker, mark a line from the coupling union nut to the bulkhead then tighten an addition wrench flat (60°). See Table 1 for torque values. Repeat for all couplings.

Coupling Size	Torque	Male Coupling	Female Coupling Nut	Female Coupling Body
3/8" (10mm)	10-12 Ft-Lbs (14-16 Nm)	3/4"	11/16"	5/8"
3/4" (19mm)	35-45 Ft-Lbs (47-61 Nm)	1-1/8"	1-5/16"	1"
7.8" (22mm)	10-12 Ft-Lbs (14-16 Nm)	1-1/8"	1-5/16"	1"

Table 1. Torque Values

ELECTRICAL WIRING

WARNING:

To avoid risk of electrical shock, personal injury, or death, disconnect all electrical power to the unit before performing any maintenance or service. The unit may have more than one electrical supply.

Label all wires prior to disconnection when servicing the unit. Wiring errors can cause improper and dangerous operation.

- All electrical connections must be in compliance with all applicable local codes and ordinances, and with the current revision of the National Electric Code (ANSI/NFPA 70).
- For Canadian installations the electrical connections and grounding shall comply with the current Canadian Electrical Code (CSA C22.1 and/or local codes).

Pre-Electrical Checklist

- ✓ Verify that the voltage, frequency, and phase of the supply source match the specifications on the unit rating plate.
- ✓ Verify that the service provided by the utility is sufficient to handle the additional load imposed by this equipment. Refer to the unit wiring label for proper voltage wiring.
- ✓ Verify factory wiring is in accordance with the unit wiring diagram (Figures 8 - 10, pages 13 - 15). Inspect for loose connections.

Line Voltage

- A wiring diagram is located on the inside cover of the electrical box of the outdoor unit. The installer should become familiar with the wiring diagram before making any electrical connections to the outdoor unit.
- **An electrical disconnect must be located within sight of and readily accessible to the unit.** This switch shall be capable of electrically de-energizing the outdoor unit.
- Line voltage to the unit should be supplied from a dedicated branch circuit containing the correct fuse or circuit breaker for the unit. Incoming field wiring and minimum size of electrical conductors and circuit

protection must be in compliance with information listed on the outdoor unit data label. Any other wiring methods must be acceptable to authority having jurisdiction.

- The outdoor unit requires both power and control circuit electrical connections. Refer to the wiring diagram / schematic for identification and location of outdoor unit field wiring interfaces (Figures 8 - 10, pages 13 - 15). Make all electrical connections in accordance with all applicable codes and ordinances.
- Overcurrent protection must be provided at the branch circuit distribution panel and sized as shown on the unit rating label and according to applicable local codes. See the unit rating plate for minimum circuit ampacity and maximum overcurrent protection limits.
- Provide power supply for the unit in accordance with the unit wiring diagram, and the unit rating plate. Connect the line-voltage leads to the terminals on the contactor inside the control compartment.
- Use only copper wire for the line voltage power supply to this unit as listed in Table 2. Use proper code agency listed conduit and a conduit connector for connecting the supply wires to the unit. Use of rain tight conduit is recommended.
- 208/230 Volt units are shipped from the factory wired for 230 volt operation. For 208V operation, remove the lead from the transformer terminal marked 240V and connect it to the terminal marked 208V.
- Optional equipment requiring connection to the power or control circuits must be wired in strict accordance of the NEC (ANSI/NFPA 70), applicable local codes, and the instructions provided with the equipment.

COPPER WIRE SIZE — AWG (1% Voltage Drop)				
Supply Wire Length-Feet				Supply Circuit Ampacity
200	150	100	50	
6	8	10	14	15
4	6	8	12	20
4	6	8	10	25
4	4	6	10	30
3	4	6	8	35
3	4	6	8	40
2	3	4	6	45
2	3	4	6	50
2	3	4	6	55
1	2	3	4	60

Wire Size based on N.E.C. for 60° type copper conductors.

Table 2. Copper Wire Size

Thermostat / Low Voltage Connections

- Thermostat connections should be made in accordance with the instructions supplied with the thermostat and the indoor equipment.
- The outdoor unit is designed to operate from a 24 VAC Class II control circuit. The control circuit wiring must comply with the current provisions of the NEC (ANSI/NFPA 70) and with applicable local codes having jurisdiction.
- The low voltage wires must be properly connected to the units low voltage terminal block. Recommended wire gauge and wire lengths for typical thermostat connections are listed in Table 3.
- The thermostat should be mounted about 5 feet above the floor on an inside wall. DO NOT install the thermostat on an outside wall or any other location where its operation may be adversely affected by radiant heat from fireplaces, sunlight, or lighting fixtures, and convective heat from warm air registers or electrical appliances. Refer to the thermostat manufacturer's instruction sheet for detailed mounting and installation information.

Thermostat Wire Gauge	Recommended T-Stat Wire Unit to T-Stat (Length in FT)	
	2-Wire (Heating)	5-Wire (Heating/Cooling)
24	55	25
22	90	45
20	140	70
18	225	110

Table 3. Thermostat Wire Gauge

Grounding

WARNING:

The unit cabinet must have an uninterrupted or unbroken electrical ground to minimize personal injury if an electrical fault should occur. Do not use gas piping as an electrical ground!

This unit must be electrically grounded in accordance with local codes or, in the absence of local codes, with the National Electrical Code (ANSI/NFPA 70) or the CSA C22.1 Electrical Code. Use the grounding lug provided in the control box for grounding the unit.

START UP & ADJUSTMENTS

Pre-Start Check List

- ✓ Verify the indoor unit is level and allows proper condensate drainage.
- ✓ Verify the outdoor coil and top of the unit are free from obstructions and debris, and all equipment access/control panels are in place.
- ✓ Verify air filters are cleaned and properly installed.
- ✓ Verify duct work is sealed to prevent air leakage.
- ✓ Verify line voltage power leads are securely connected and the unit is properly grounded.
- ✓ Verify low voltage wires are securely connected to the correct leads on the low voltage terminal strip.
- ✓ Verify power supply branch circuit overcurrent protection is sized properly.
- ✓ Verify the thermostat is wired correctly.

Start-Up Procedures

The thermostat's function mode should be set to OFF and the fan mode should be set to AUTO. Close all electrical disconnects to energize the system.

Air Circulation - Indoor Blower

1. Set the thermostat system mode on OFF and the fan mode to ON.
2. Verify the blower runs continuously. Check the air delivery at the supply registers and adjust register openings for balanced air distribution. If insufficient air is detected, examine ductwork for leaks or obstructions.
3. Set the thermostat fan mode to AUTO and verify the blower stops running.

System Cooling

1. Set the thermostat's system mode to COOL and the fan mode to AUTO. Gradually lower the thermostat temperature setpoint below room temperature and verify the outdoor unit and indoor blower energize.
2. Verify blower wheel is spinning in direction indicated by arrow. Feel the air being circulated by the indoor blower and verify that it is cooler than ambient temperature. Listen for any unusual noises. If unusual sounds occur, determine the source of the noise and correct as necessary.
3. Verify HI and LO refrigerant pressures.
4. Allow the system to operate for several minutes and then set the temperature selector above room temperature. Verify the fan and compressor cycle off with the thermostat. **NOTE:** The blower should also stop unless fan mode is set to the ON position.

System Heating (optional)

1. Set the thermostat's system mode to HEAT and the temperature mode above room temperature.
2. Verify the optional heating equipment (furnace or electric heat) and indoor blower energize. Feel the air being circulated by the indoor blower and verify that it is warmer than ambient temperature. Listen for any unusual noises. If unusual sounds occur, determine the source of the noise and correct as necessary.

REFRIGERANT CHARGING

WARNING:

S6QD Split System Air Conditioners are shipped fully charged with R410A refrigerant and ready for installation. When system is installed according to these instructions, no refrigerant charging is required. If repairs make it necessary for evacuation and charging, it should only be attempted by qualified trained personnel thoroughly familiar with this equipment. Under no circumstances should the owner attempt to install and/or service this equipment. Failure to comply with this warning could result in property damage, personal injury, or death.

After refrigerant line connections are completed, it is required that you leak check all line connections (using proper methods) before finalizing the full system refrigerant charge.

- Refrigerant charging charts are applicable only to matched equipment and listed airflows for the indoor coil. Refer to Figures 2 - 7 (pages 10 - 12) for correct system charging.
- Use of S6QD outdoor units with non-AHRI listed indoor coils is not recommended. Deviations from rated airflows or non-listed combinations may require modification to the expansion device and refrigerant charging procedures for proper and efficient system operation.
- The refrigerant charge can be checked and adjusted through the service ports provided external to the outdoor unit. Use only gage line sets which have a "Schrader" depression device present to actuate the valve.

Charging the unit in AC mode

(With outdoor temperatures above 65° F)

1. With the system operating at steady-state, measure the liquid refrigerant pressure (in psig) at the outdoor unit service valve.
2. Measure the liquid refrigerant temperature (in Fahrenheit) at the service valve.
3. Determine the required liquid refrigerant pressure from Tables 4 - 6 (page 9).
 - If the pressure measured in Step 1 is greater than the required liquid refrigerant pressure determined in Step 3, then there is too much charge in the system. Remove refrigerant and repeat Steps 1 through 3 until the system is correctly charged.
 - If the pressure measured in Step 1 is less than the required liquid refrigerant pressure determined in Step 3, there is too little charge in the system. Add refrigerant and repeat Steps 1 through 3 until the system is correctly charged.

AIR CONDITIONER MAINTENANCE

WARNING:

To prevent electrical shock, personal injury, or death, disconnect all electrical power to the unit before performing any maintenance or service. The unit may have more than one electrical supply.

Proper maintenance is important to achieve optimum performance from the air conditioner. The ability to properly perform maintenance on this equipment requires certain mechanical skills and tools. If you do not possess these skills, contact your dealer for maintenance. Consult your local dealer about the availability of maintenance contracts. Routine maintenance should include the following:

- Inspect and clean or replace air filters at the beginning of each heating and cooling season, or more frequently if required.
- Inspect the condensate drain and outdoor coil at the beginning of each cooling season. Remove any debris. Clean the outdoor coil and louvers as necessary using a mild detergent and water. Rinse thoroughly with water.
- Inspect the electrical connections for tightness at the beginning of each heating and cooling season. Service as necessary.

CAUTION:

The unit should never be operated without a filter in the return air system. Replace disposable filters with the same type and size.

- Do not add additional oil to motors unequipped with oil tubes. The compressor is hermetically sealed at the factory and does not require lubrication.

COMPONENT FUNCTIONS

High Pressure Switch (HPS) - A high-pressure switch is factory-installed and located in the liquid line internal to the outdoor unit. The switch is designed to protect the system when very high pressures occur during abnormal conditions. Under normal conditions, the switch is closed. If the liquid pressure rises above 575 psig, then the switch will open and de-energize the outdoor unit. The switch will close again once the liquid pressure decreases to 460 psig. Please note that the switch interrupts the thermostat inputs to the unit. Thus, when the switch opens and then closes, there may be a 5 minute short cycling delay before the outdoor unit will energize.

Low-Pressure Switch - (Select Models) A low-pressure switch is factory-installed and located in the suction line internal to the outdoor unit. The switch is designed to protect the compressor from a loss of charge. Under normal conditions, the switch is closed. If the suction pressure falls below 5 psig, then the switch will open and de-energize the outdoor unit. The switch will close again once the suction pressure increases above 20 psig. Please note that the switch interrupts the thermostat inputs to the unit. When the switch opens and then closes, there will be a 5 minute short cycling delay before the outdoor unit will energize.

REPLACEMENT PARTS

Replacement parts are available through your distributor. Please have the complete model and serial number of the unit when ordering replacement parts.

Electrical

Capacitors	Temperature Limit Switches
Compressors	Thermostats
Contactors	Time Delay Relays
Pressure Switches	Transformers
Relays	

Motors



Blower Motor	Fan Motor
--------------	-----------

Components

Blower Assembly	Fan Grille
Cabinet Panels	Filter/Driers
Expansion Valves	

APPLICATION NOTES FOR USING S6QD REFRIGERANT CHARGING CHARTS & TABLES - COOLING ONLY

LEGEND

-  Shaded boxes indicate flooded conditions.
-  Rated design values. The suction pressure will be lower than design value if outdoor air flow, entering dry bulb, or entering wet bulb temperatures are lower than design.

NOTES:

1. All pressures are listed psig and all temperatures in °F
2. Discharge temperatures GREATER than charted values indicate an UNDERCHARGED system.
3. Discharge temperatures LESS than charted values indicate an OVERCHARGED system.

- **This equipment's cooling system contains refrigerant under high pressure. Always use safe and environmentally sound methods when handling refrigerant handling or servicing the unit. Review the factory literature and safety warnings prior to servicing.**
- When repairing system leaks, always use a nitrogen (inert) gas to protect the refrigerant system and pressure check the repair before re-charging. Always replace the filter-dryers when performing any repair to the refrigeration system with one capable of acid removal. After completing the repairs, evacuate the system to 350 - 500 microns and weigh in the refrigerant to the amount specified on the unit rating label.
- The refrigerant charging charts and tables are valid for a variety of indoor, return air conditions and are most influenced by the outdoor ambient temperature, outdoor fan operation and the unit operating voltage. Before using these tables and charts, make sure the unit is in a stable operating mode. As shown in Tables 4 - 6 (page 9) and Figures 2 - 7 (pages 10 - 12), the ideal system sub-cooling can vary over the range of operation. Reference the tables to determine the ideal amount of sub-cooling for a given liquid pressure. Units charged to other values will not perform at the rated unit efficiency (EER) or rated Coefficient of Performance (COP) in heating mode.
- To inspect a systems operation using quality instruments, match the measured liquid temperature to the units table. The measured liquid pressure reading should be within 3% of the table value for most installations.
- For systems that are operating with more than a 5% deviation, inspect the unit for the proper voltage and phase balance and the refrigeration system for leaks.
- Units that are operating at less then 95% of the nominal voltage or with a 2% phase imbalance may see a more significant deviation than the amount stated above.
- **DO NOT** use the tables in systems that have a fan cycling under low-ambient control. Refer to the low-ambient kit instructions for more information. (If applicable)

Suct. Press.	OUTDOOR TEMPERATURE (° F)															
	70		75		80		85		90		95		100		105	
	Liq. Press.	Dis. Temp.	Liq. Press.	Dis. Temp.	Liq. Press.	Dis. Temp.	Liq. Press.	Dis. Temp.	Liq. Press.	Dis. Temp.	Liq. Press.	Dis. Temp.	Liq. Press.	Dis. Temp.	Liq. Press.	Dis. Temp.
128	261	132														
130	262	136	283	136												
132	263	140	284	140	305	140										
134	264	145	285	144	306	144	327	145								
136	265	149	286	149	307	148	328	149	349	149						
138			287	153	308	152	329	153	350	153	371	154				
140					309	157	330	157	351	157	372	157	393	158		
142							331	161	352	161	373	161	394	162	416	163
144							332	165	353	165	374	165	395	165	417	166
146									354	168	375	169	396	169	418	170
148											376	172	398	173	419	173
150													399	176	420	177
152															421	180
154																

Table 4. Charging Table for S6QD-024KA Series (2 Ton Units) - Orifice Matches

Suct. Press.	OUTDOOR TEMPERATURE (° F)															
	70		75		80		85		90		95		100		105	
	Liq. Press.	Dis. Temp.	Liq. Press.	Dis. Temp.	Liq. Press.	Dis. Temp.	Liq. Press.	Dis. Temp.	Liq. Press.	Dis. Temp.	Liq. Press.	Dis. Temp.	Liq. Press.	Dis. Temp.	Liq. Press.	Dis. Temp.
129	261	134														
131	262	138	284	137												
133	263	142	285	141	308	141										
135	264	145	286	145	309	145	331	145								
137	265	148	288	148	310	149	332	148	355	148						
139			289	152	311	152	333	152	356	152	378	152				
141					312	156	335	156	357	156	379	156	402	156		
143							336	159	358	159	380	159	403	159	425	159
145							337	163	359	163	382	163	404	163	426	163
147									361	166	383	166	405	166	427	166
149											384	170	406	170	429	170
151													408	173	430	173
153															431	177
155																

Table 5. Charging Table for S6QD-030KA Series (2.5 Ton Units) - Orifice Matches

Suct. Press.	OUTDOOR TEMPERATURE (° F)															
	70		75		80		85		90		95		100		105	
	Liq. Press.	Dis. Temp.	Liq. Press.	Dis. Temp.	Liq. Press.	Dis. Temp.	Liq. Press.	Dis. Temp.	Liq. Press.	Dis. Temp.	Liq. Press.	Dis. Temp.	Liq. Press.	Dis. Temp.	Liq. Press.	Dis. Temp.
131	268	126														
133	269	129	290	132												
135	270	133	292	134	312	137										
137	271	137	293	137	314	139	335	142								
139	272	140	294	141	315	142	336	145	357	148						
141			295	145	316	146	338	147	358	150	379	154				
143					317	149	339	150	360	152	381	155	401	159		
145							340	154	361	155	382	157	403	160	423	165
147							341	157	362	158	384	160	405	162	425	166
149									364	162	385	163	406	164	427	167
151											386	166	407	168	429	169
153													409	171	430	172
155															431	175
157																

Table 6. Charging Table for S6QD-036KA Series (3 Ton Units) - Orifice Matches

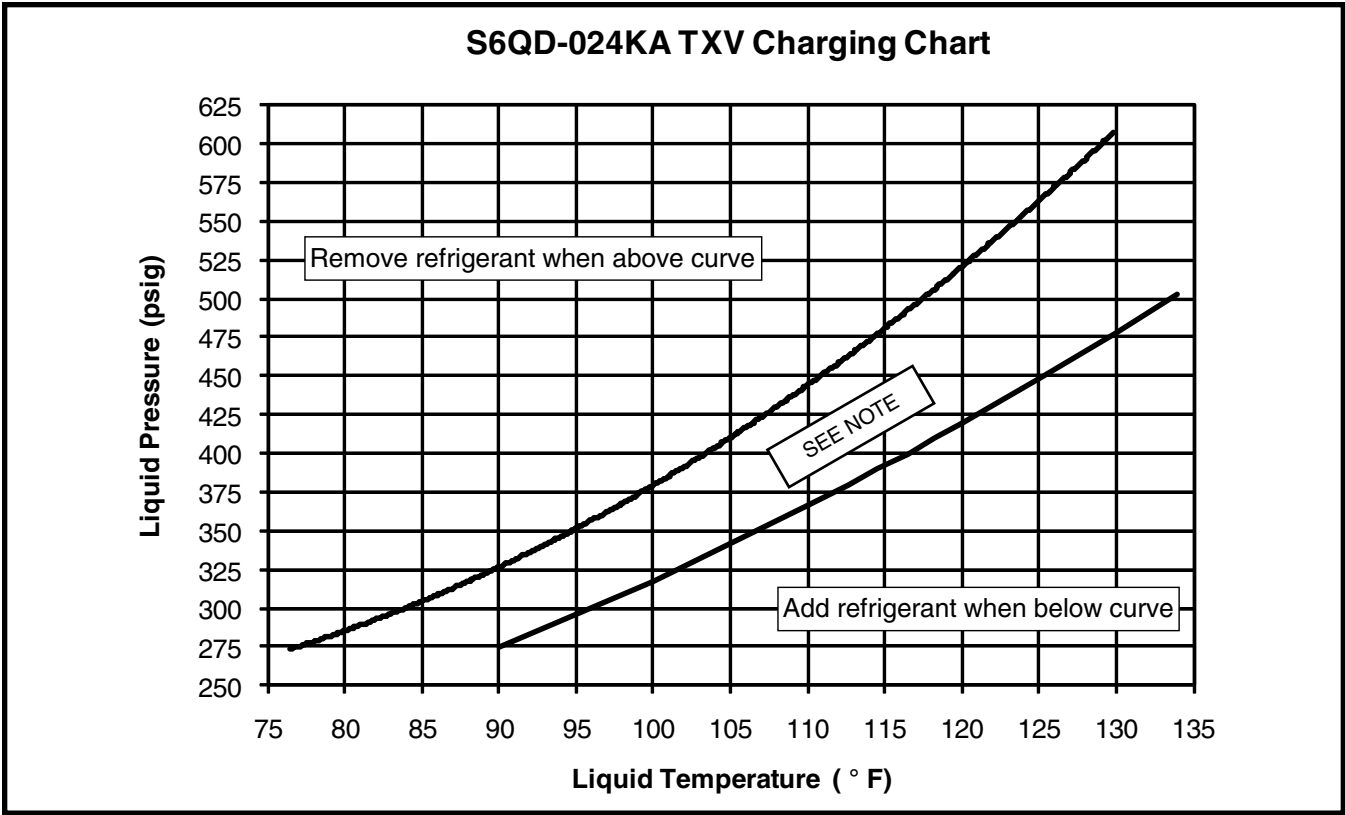

Figure 2. Charging Chart for 2 Ton Units

NOTE: Do not add or remove refrigerant if pressure reading is between the curves.

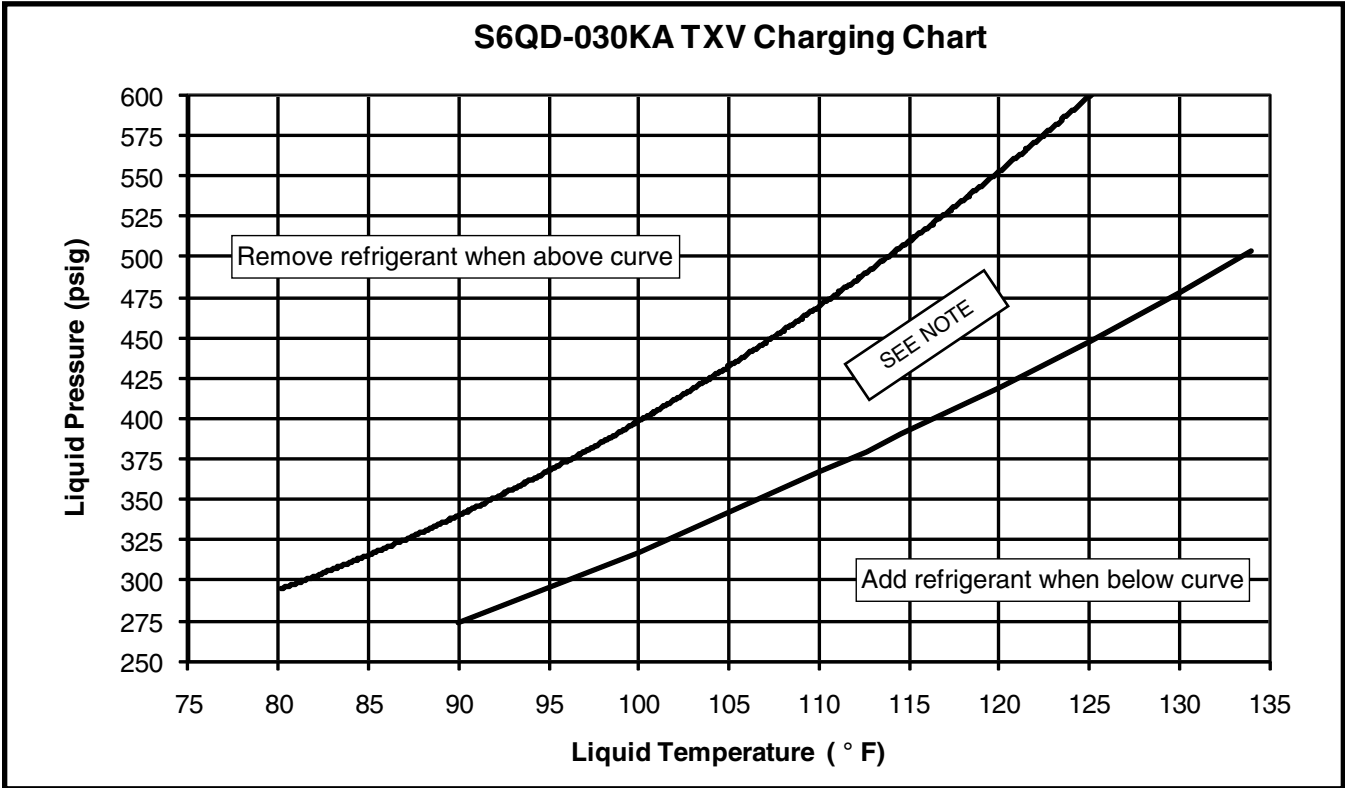

Figure 3. Charging Chart for 2.5 Ton Units

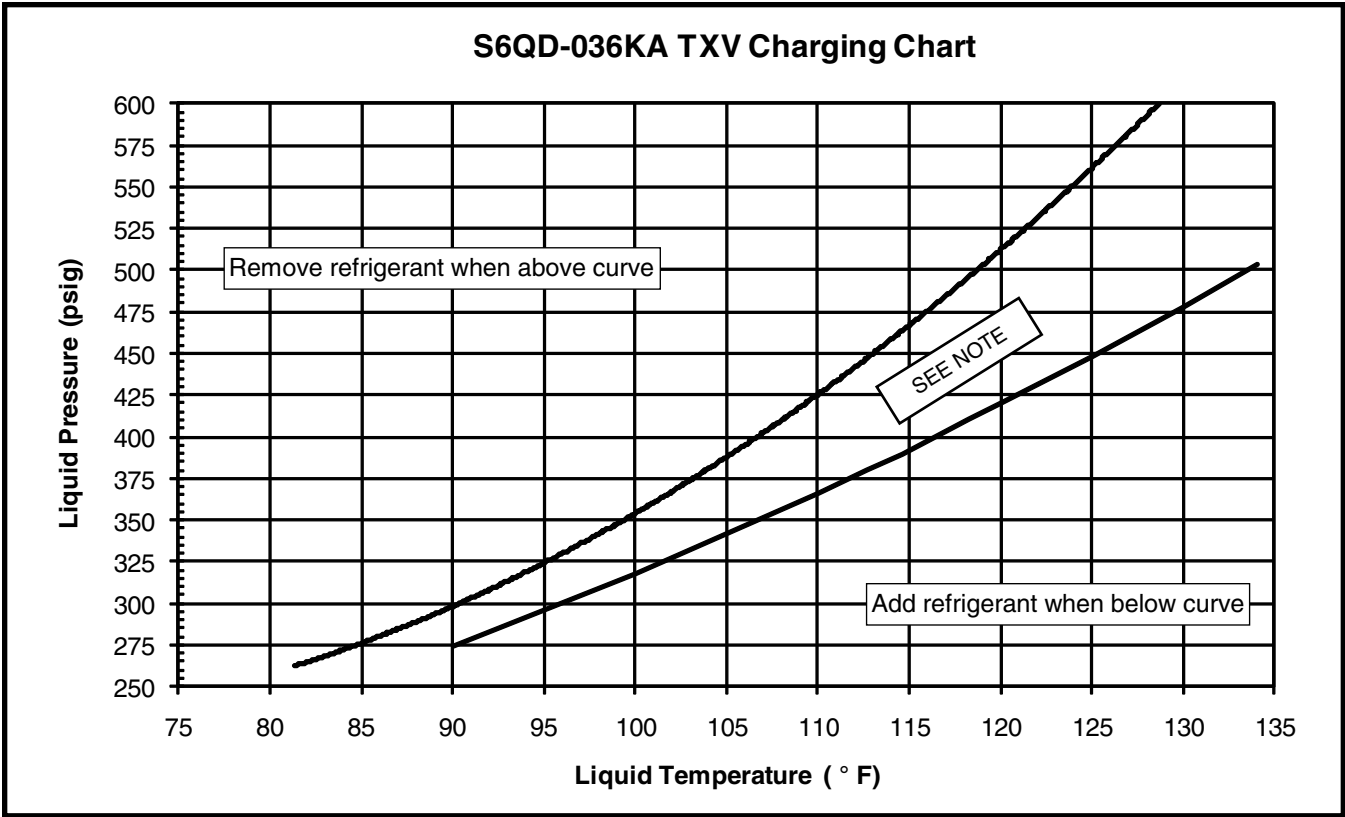

Figure 4. Charging Chart for 3 Ton Units

NOTE: Do not add or remove refrigerant if pressure reading is between the curves.

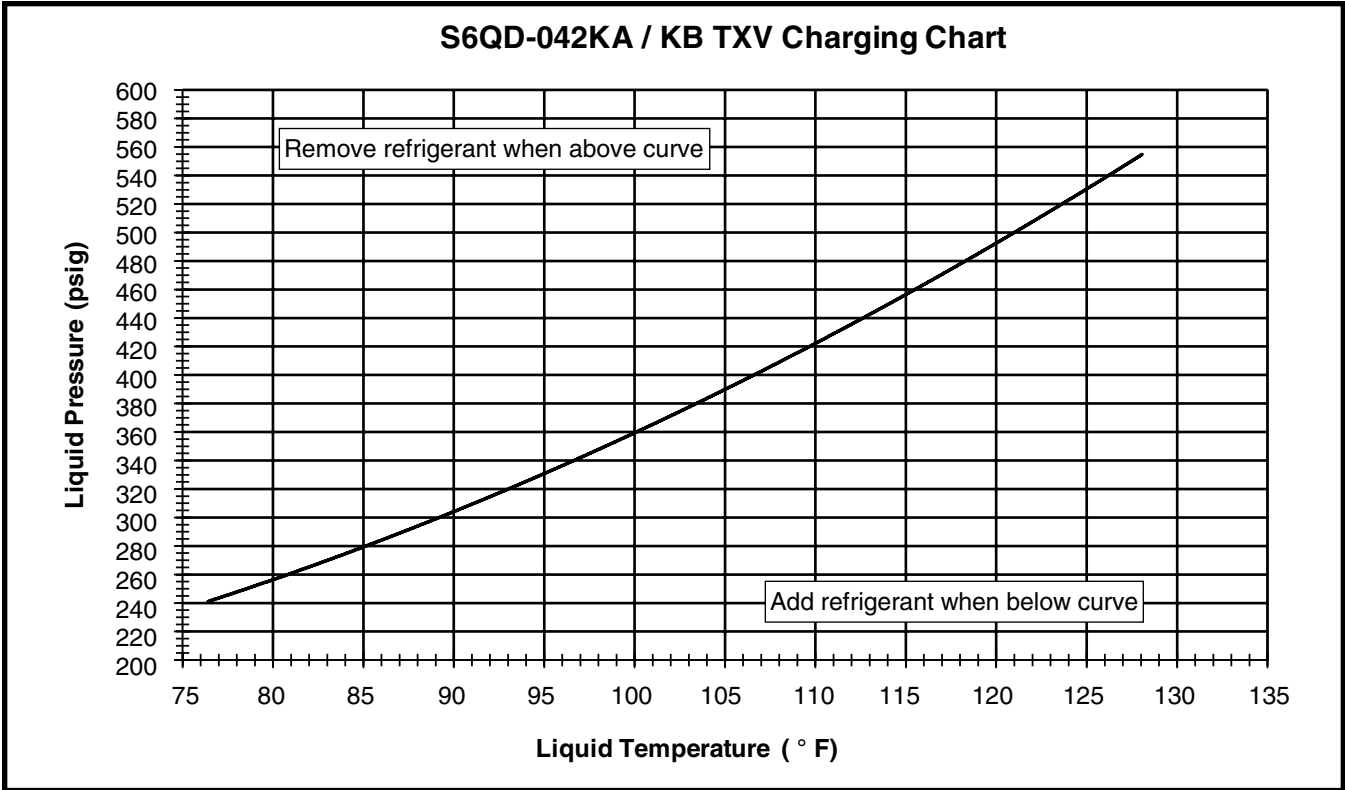

Figure 5. Charging Chart for 3.5 Ton Units

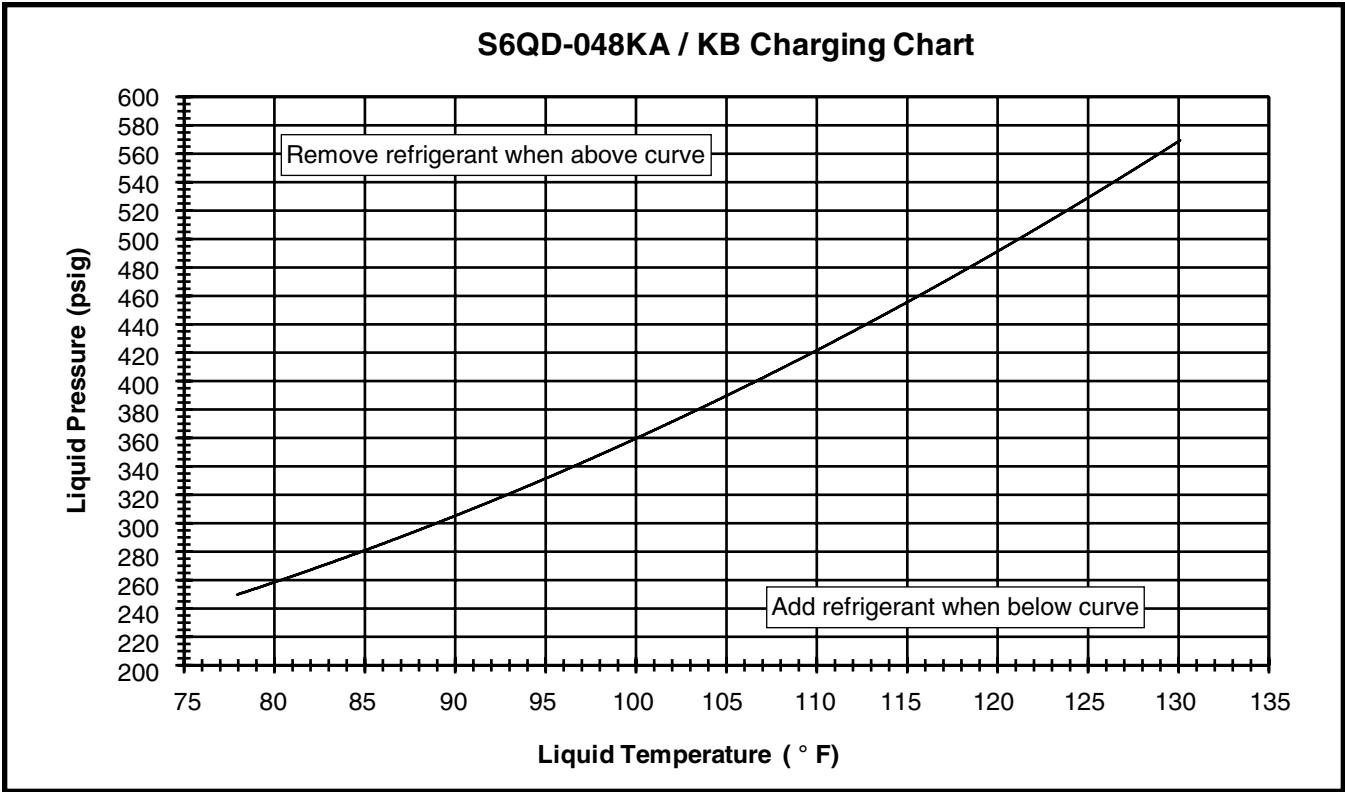

Figure 6. Charging Chart for 4 Ton Units

NOTE: Do not add or remove refrigerant if pressure reading is between the curves.

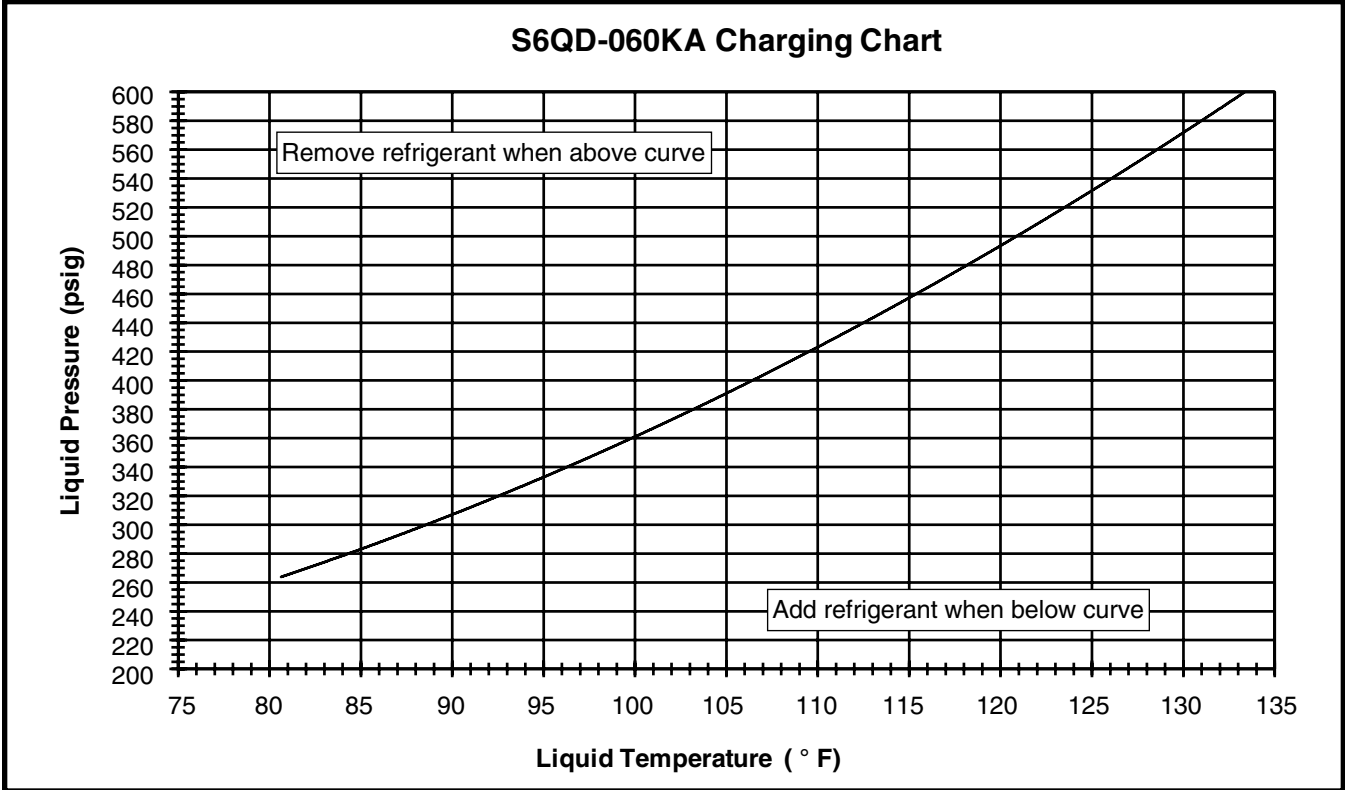

Figure 7. Charging Chart for 5 Ton Units

WIRING DIAGRAMS

WIRING DIAGRAM

Split System Air Conditioner(Outdoor Section)

Single Phase

NOTES:

1. Disconneball power before servicing.
2. For supply connections use copper conductors only.
3. Not suitable on systems that exceed 150 volts to ground.
4. For replacement wires use conductors suitable for 105 deg C.
5. For ampacities and overcurrent protection, see unit rating plate.
6. Connect to 24 vac/40ca/class 2 circuit. See furnace/airhandler installation instructions for control circuit and optional relay/transformer kits.
7. Anti-Short Cycle Timer (ASCT) may or may not be installed in the unit. If desired, ASCT is factory installed on select models only or may be field installed as shown using manufacturer's approved kit. If not present, connect Yellow and Black wires per Note 6.
8. DO NOT use a Hard Start Kit on a model with a PTCR installed.

1. Couper le courant avant de faire letretien.
2. Employez uniquement des conducteurs en cuivre.
3. Ne convient pas aux installations de plus de 150 volt a la terre.

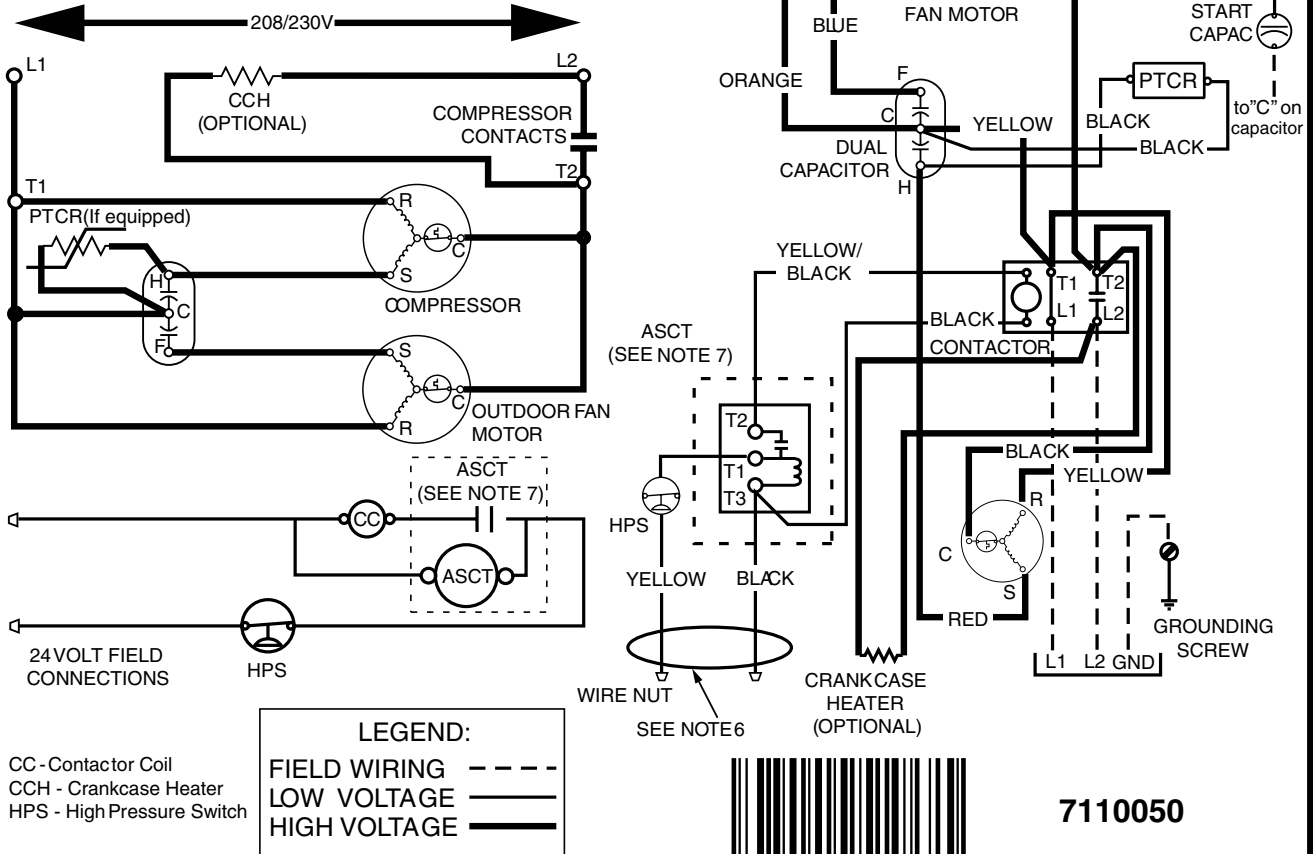

Figure 8. S6QD Wiring Diagram (2 - 3 Ton Units)

WIRING DIAGRAM

Split System Air Conditioner (Outdoor Section)

Single Phase

NOTES:

1. Disconnect all power before servicing.
2. For supply connections use copper conductors only.
3. Not suitable on systems that exceed 150 volts to ground.
4. For replacement wires use conductors suitable for 105 deg C.
5. For ampacities and overcurrent protection, see unit rating plate.
6. Connect to 24 vac/40ca/class 2 circuit. See furnace/airhandler installation instructions for control circuit and optional relay/transformer kits.
7. Anti-Short Cycle Timer (ASCT) may or may not be installed in the unit. If desired, ASCT is factory installed on select models only or may be field installed as shown using manufacturer's approved kit. If not present, connect Yellow and Black wires per Note 6.

1. Couper le courant avant de faire leretien.
2. Employez uniquement des conducteurs en cuivre.
3. Ne convient pas aux installations de plus de 150 volt a la terre.

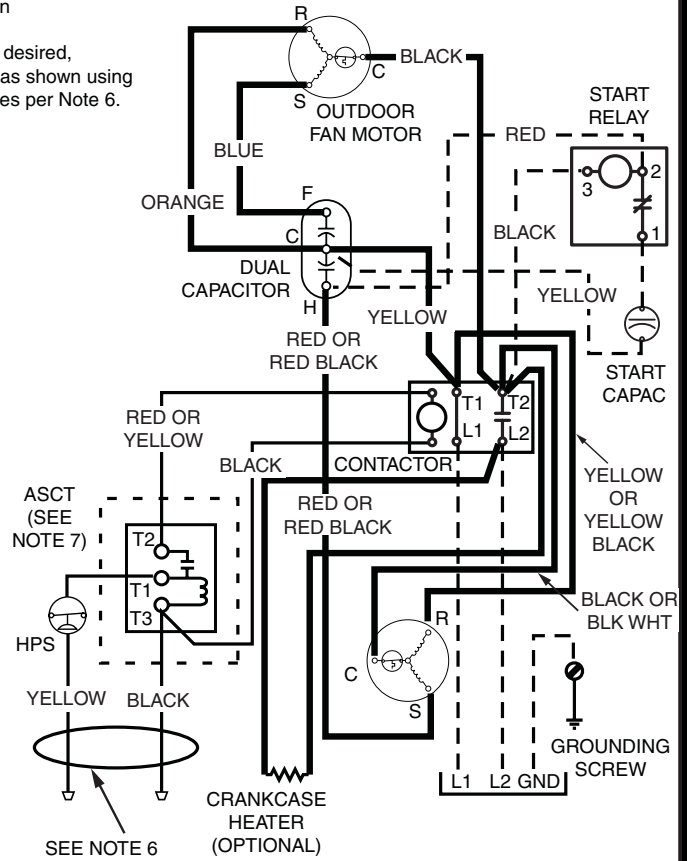
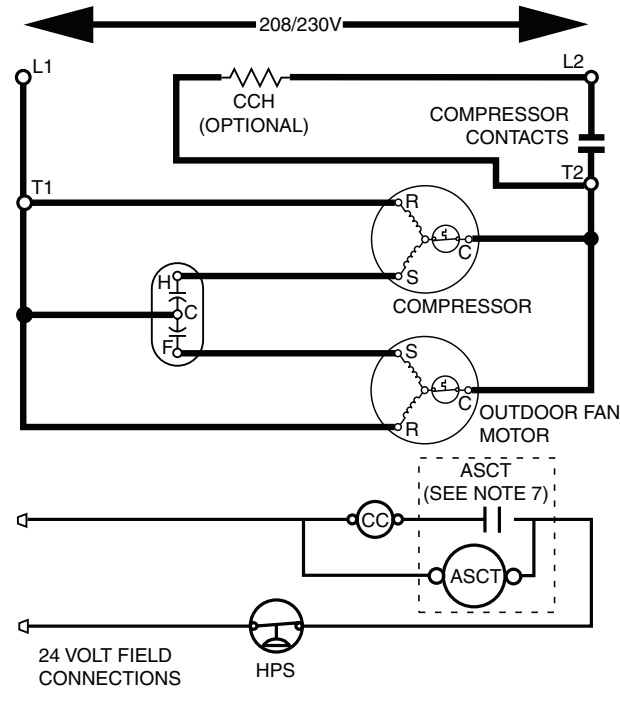

LEGEND:

CC - Contactor Coil
 CCH - Crankcase Heater
 HPS - High Pressure Switch

FIELD WIRING	---
LOW VOLTAGE	— — —
HIGH VOLTAGE	—————



710388B
 (Replaces 710388A)

0109

Figure 10. S6QD Wiring Diagram (3.5 - 5 Ton Units)

INSTALLATION / PERFORMANCE CHECK LIST

INSTALLATION ADDRESS:		
CITY _____	STATE _____	
UNIT MODEL # _____		
UNIT SERIAL # _____		
Unit Installed Minimum clearances per Figure 1 (page 3)?	YES	NO
INSTALLER NAME:		
CITY _____	STATE _____	

REFRIGERATION SYSTEM		
Was unit given 24 hr warm up period for crankcase heaters?	YES	NO
Stage-1 Liquid Pressure (high side) _____		
Stage-1 Suction Pressure (low side) _____		
Has the owner's information been reviewed with the customer?	YES	NO
Has the Literature Package been left with the unit?	YES	NO

ELECTRICAL SYSTEM		
Electrical connections tight?	YES	NO
Line voltage polarity correct?	YES	NO
Rated Voltage: _____ VOLTS		
L1-L2 Volts: _____ VOLTS		
L1-L3 Volts: _____ VOLTS		
L2-L3 Volts: _____ VOLTS		
Avg. Volts: _____ VOLTS		
Max. deviation of voltage from avg. volts: _____ VOLTS		
% Volt imbalance: _____ VOLTS		
Blower Motor HP: _____ Sheave Setting _____ # Turns		
Has the thermostat been calibrated?	YES	NO
Is the thermostat level?	YES	NO
Is the heat anticipator setting correct? (If Applicable)	YES	NO

