

Outdoor Air Conditioner

User's Information and Installation Instructions

13+ SEER Extra High Efficiency Split System

These units have been designed and tested for capacity & efficiency in accordance with A.H.R.I. Standards. Split System Air Conditioning units are designed for use with a wide variety of fossil fuel furnaces, electric furnaces, air handlers, and evaporator coil combinations.

These instructions are primarily intended to assist qualified individuals experienced in the proper installation of heating and/or air conditioning appliances. Some local codes require licensed installation/service personnel for this type of equipment. Read all instructions carefully before starting the installation.

USER'S INFORMATION

IMPORTANT

Read this owner information to become familiar with the capabilities and use of your appliance. Keep this with literature on other appliances where you have easy access to it in the future.

If a problem occurs, check the instructions and follow recommendations given. If these suggestions don't eliminate your problem, call your servicing contractor.

OPERATING INSTRUCTIONS

To Operate Your Air Conditioner for Cooling —

1. Set the thermostat system switch to COOL or AUTO and the thermostat fan switch to AUTO. (See Figure 1)
2. Set the thermostat temperature to the desired temperature level using the temperature selector. Please refer to the separate thermostat user's manual for complete instructions regarding thermostat programming. The outdoor unit and indoor blower will both cycle on and off to maintain the indoor temperature at the desired cooling level.

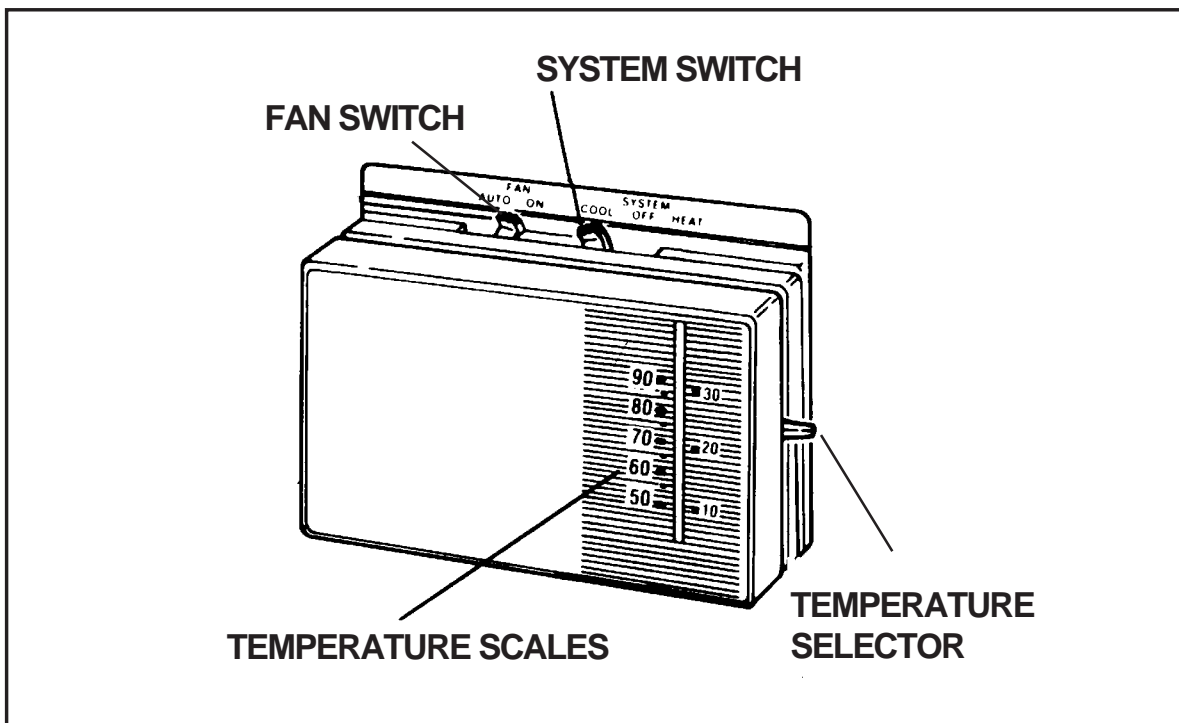

Figure 1. Typical Thermostat

To Operate Your Furnace for Heating —

1. Set the thermostat system switch to HEAT or AUTO and the thermostat fan switch to AUTO. (See Figure 1)
2. Set the thermostat temperature to the desired temperature level using the temperature selector. Please refer to the separate user's manual for complete thermostat programming instructions. The furnace and indoor blower will cycle on and off to maintain the indoor temperature at the desired heating level.

To Shut Off Your Air Conditioner —

Set the thermostat system switch to OFF and the thermostat fan switch to AUTO. (See Figure 1)

The system will not operate, regardless of the thermostat temperature setting.

To Operate the Indoor Blower Continuously —

Set the thermostat fan switch to ON (See Figure 1)

The indoor blower will start immediately, and will run continually until the fan switch is reset to AUTO.

The continuous indoor blower operation can be obtained with the thermostat system switch set in any position, including OFF.

The continuous indoor blower operation is typically used to circulate the indoor air to equalize a temperature unbalance due to a sun load, cooking, or fireplace operation.

To Maintain Your Air Conditioner —

**CAUTION:**

Be certain the electrical power to the outdoor unit and the furnace/air handler is disconnected before doing the following recommended maintenance.

1. Regularly:

- a. Clean or replace the indoor air filter at the start of each heating and cooling season, and when an accumulation of dust and dirt is visible on the air filter.
- b. Remove any leaves and grass clippings from the coil in the outdoor unit, being careful not to damage the aluminum fins.
- c. Check for any obstruction, such as twigs, sticks, etc.
- d. Certain models have external panels fabricated from a premium grade of stainless steel designed to inhibit corrosion. For such units, if the unit is located in a coastal region or other area subjected to high concentrations of salt, then the unit should be hosed off after storms and monthly otherwise to maintain its new appearance.

2. Before Each Cooling Season:

If the furnace/air handler blower motor and the outdoor unit fan motor(s) have oil tubes at the motor bearings, apply 10 drops of SAE No. 20 motor oil to each oil tube.

**CAUTION:**

Do not over-oil, or oil motors not factory-equipped with oil tubes. The compressor is hermetically “sealed” and does not require lubrication.

3. Before Calling a Service Technician, Be Certain:

- a. The unit thermostat is properly set—see “To Operate Your Air Conditioner for Cooling” and “To Operate Your Furnace for Heating.”
 - b. The unit disconnect fuses are in good condition, and the electrical power to the unit is turned on.
-

1. GENERAL INFORMATION

Read the following instructions completely before performing the installation.

Condensing Unit Section — Each condensing unit is shipped with a refrigerant charge adequate to operate the outdoor section with an indoor matching coil or air handler, and 15 feet of refrigeration line.

NOTE: DO NOT USE ANY PORTION OF THE CHARGE FOR PURGING OR LEAK TESTING.

Matching coils and air handlers are shipped with a small pressurized holding charge to pressurize them to keep out contaminants. To release the pressure, carefully read the installation instructions provided with the indoor coil or air handler.

Liquid and Suction Lines — Refrigerant grade copper tubing should be used when installing the system. Refrigerant suction line tubing should be fully insulated.

Field Connections for Electrical Power Supply — All wiring must comply with current revisions of the National Electrical Code (ANSI/NFPA 70) and with applicable local codes having jurisdiction. The minimum size of electrical conductors and circuit protection must be in compliance with information listed on the outdoor unit data label.

2. SAFETY CONSIDERATIONS

Pressures within the System — Split system air conditioning equipment contains liquid and gaseous refrigerant under pressure. Installation and servicing of this equipment should be performed by qualified, trained personnel thoroughly familiar with this type of equipment. Under no circumstances should the Homeowner attempt to install and/or service the equipment.

Labels, Tags, Precautions — When working with this equipment, follow all precautions in the literature, on tags, and on labels provided with the equipment. Read and thoroughly understand the instructions provided with the equipment prior to performing the installation and operational checkout of the equipment.

Brazing Operations — Installation of equipment may require brazing operations. Safety codes must be complied with. Safety equipment (e.g.; safety glasses, work gloves, fire extinguisher, etc.) must be used when performing brazing operations.

**WARNING:**

Ensure all electrical power to the unit is off prior to installing or servicing the equipment. Failure to do so may cause personal injury or death.

3. SITE PREPARATION

Unpacking Equipment — Remove the cardboard carton and User's Manual from the equipment. Take care not to damage the tubing connections when removing the carton.

Inspect for Damage — Inspect the equipment for damage prior to installing the equipment at the job site. Ensure coil fins are straight and, if necessary, comb fins to remove flattened and bent fins.

Preferred Location of the Outdoor Unit at the Job Site — Conduct a survey of the job site to determine the optimum location for mounting the outdoor unit. Overhead obstructions, poorly ventilated areas, and areas subject to accumulation of debris should be avoided. The outdoor unit should be installed no closer than 18 inches from the outside walls of the facility and in an area free from overhead obstructions to ensure unrestricted airflow through the outdoor unit.

Facility Prerequisites — Electrical power must be supplied to the equipment. Electrical power supplied must be adequate for proper operation of the equipment. The system must be wired and provided with circuit protection in accordance with local building codes and the National Electrical Code.

Minimum Circuit Ampacity — Electrical wiring to the equipment must be compatible and in compliance with the minimum circuit ampacity listed on the outdoor unit data label.

Maximum Fuse/Circuit Breaker Size — Circuit protection for the outdoor unit must be compatible with the maximum fuse/circuit breaker size listed on the outdoor unit data label.

4. INSTALLING THE OUTDOOR UNIT

Slab Mount — The site selected for a slab mount installation requires a stable foundation and one

not subject to erosion. The slab should be level and anchored (if necessary) prior to placing the equipment on the slab.

Cantilever Mount — The cantilever mount should be designed with adequate safety factor to support the weight of the equipment, and for loads subjected to the mount during operation. Installed equipment should be adequately secured to the cantilever mount and levelled prior to operation of the equipment.

Roof Mount — The method of mounting should be designed so as not to overload roof structures nor transmit noise to the interior of the structure. Refrigerant and electrical line should be routed through suitably waterproofed openings to prevent water leaking into the structure.

5. INSTALLING THE INDOOR UNIT

The indoor section should be installed before proceeding with routing of refrigerant piping. Consult the installation instructions of the indoor unit (i.e.: air handler, furnace, etc.) for details regarding installation.

6. CONNECTING REFRIGERANT TUBING BETWEEN THE INDOOR AND OUTDOOR UNIT

General — Once outdoor and indoor unit placement has been determined, route refrigerant tubing between the equipment in accordance with sound installation practices. Refrigerant tubing should be routed in a manner that minimizes the length of tubing and the number of bends in the tubing. Refrigerant tubing should be supported in a manner that the tubing will not vibrate or abrade during system operation. Tubing should be kept clean of foreign debris during installation and installation of a liquid line filter drier is recommended if cleanliness or adequacy of system evacuation is unknown or compromised. Every effort should be made by the installer to ensure that the field installed refrigerant containing components of the system have been installed in accordance with these instructions and sound installation practices so as to insure reliable system operation and longevity. The maximum recommended interconnecting refrigerant line length is 75 feet, and the vertical elevation dif-

ference between the indoor and outdoor sections should not exceed 20 feet.

Filter Dryer Installation — A filter dryer is provided with PS series models only and must be installed in the liquid line of the system. If the installation replaces a system with a filter dryer already present in the liquid line, the filter dryer must be replaced with the one supplied with the unit. The filter dryer must be installed in strict accordance with the manufacturer's installation instructions.

For all other series models, installing a filter dryer is optional. However, it is good installation practice to install a filter dryer when replacing the evaporator and/or condenser of a system. When installing, the filter dryer must be installed in strict accordance with the manufacturer's installation instructions.

Optional Equipment — Optional equipment (e.g.: liquid line solenoid valves, etc.) should be installed in strict accordance with the manufacturer's installation instructions.

7. MAKING ELECTRICAL CONNECTIONS

WARNING:

Turn off all electrical power at the main circuit box before wiring electrical power to the outdoor unit. Failure to comply may cause severe personnel injury or death.

Wiring Diagram/Schematic — A wiring diagram/schematic is located on the inside cover of the electrical box of the outdoor unit. The installer should become familiar with the wiring diagram/schematic before making any electrical connections to the outdoor unit.

Outdoor Unit Connections — The outdoor unit requires both power and control circuit electrical connections. Refer to the unit wiring diagram/schematic for identification and location of outdoor unit field wiring interfaces.

Control Circuit Wiring — The outdoor unit is designed to operate from a 24 VAC Class II control circuit. Control circuit wiring must comply with

the current provisions of the National Electrical Code (ANSI/NFPA 70) and with applicable local codes having jurisdiction.

Thermostat Connections — Thermostat connections should be made in accordance with the instructions supplied with the thermostat, and with the instructions supplied with the indoor equipment.

Electrical Power Wiring — Electrical power wiring shall comply with the current provisions of the National Electrical Code (ANSI/NFPA 70) and with applicable local codes having jurisdiction. Use of rain tight conduit is recommended. Electrical conductors shall have minimum circuit ampacity in compliance with the outdoor unit rating label. The facility shall employ electrical circuit protection at a current rating no greater than that indicated on the outdoor unit rating label.

Disconnect Switch — An electrically compatible disconnect switch must be within line of sight of the outdoor unit. This switch shall be capable of electrically de-energizing the outdoor unit.

Optional Equipment — Optional equipment requiring connection to the power or control circuits must be wired in strict accordance with current provisions of the National Electrical Code (ANSI/NFPA 70), with applicable local codes having jurisdiction, and the installation instructions provided with the equipment. Optional Equipment (e.g.: liquid line solenoid valves, hard start kits, low suction pressure cutout switch kit, high pressure cutout switch kit, refrigerant compressor crankcase heater, etc.) should be installed in strict accordance with the manufacturer's installation instructions.

8. STARTUP AND CHECKOUT

WARNING:

Ensure electrical power to the unit is off prior to performing the following steps. Failure to do so may cause personal injury or death.

Air Filters — Ensure air filters are clean and in place prior to operating the equipment.

Thermostat — Set the room thermostat function switch to OFF, fan switch to AUTO, and move

temperature setpoint to its highest setting. Prior to applying electrical power to the outdoor unit, ensure that the unit has been properly and securely grounded, and that power supply connections have been made at both the facility power interface and outdoor unit.

Outdoor Unit — Ensure the outdoor coil and top of the unit are free from obstructions and debris, and all equipment access/control panels are in place.

Using extreme caution, apply power to the unit and inspect the wiring for evidence of open, shorted, and/or improperly wired circuits.

Functional Checkout:

CAUTION:

If equipped with a compressor crankcase heater, wait 24 hours prior to performing a function checkout to allow for heating of the compressor crankcase. Failure to comply may result in damage and could cause premature failure of the system.

Indoor Blower — Set the thermostat function switch to COOLING and the fan switch to ON. Verify that the indoor blower is operating and that airflow is not restricted. Set the fan switch back to AUTO.

Positive Temperature Coefficient Resistor (PTCR) — (select models) A PTCR is factory installed and located on the control panel of the outdoor unit. The PTCR is a soft start device for use with reciprocating compressors. If a hard start kit is needed on this model the soft start (PTCR) must be removed first.

Low-Pressure Switch — A low-pressure switch is factory-installed in select models only. If provided, this switch is located in the suction line internal to the outdoor unit. The switch is designed to protect the compressor from a loss of charge. Under normal conditions, the switch is closed. If the suction pressure falls below 5 psig, then the switch will open and de-energize the outdoor unit. The switch will close again once the suction pressure increases above 20 psig.

Comfort Alert™ Diagnostics (Select Models)

— The Comfort Alert™ diagnostics is a breakthrough innovation for troubleshooting heat pump and air conditioning system failures. The module installs easily in the electrical box of the outdoor unit near the compressor contactor. By monitoring and analyzing data from the Copeland Scroll compressor® and the thermostat demand, the module can accurately detect the cause of electrical and system related failures without any sensors. A flashing LED indicator communicates the ALERT code and guides the service technician more quickly and accurately to the root cause of a problem.

NOTE: This module does not provide safety protection! The Comfort Alert module is a monitoring device and cannot shut down the compressor directly.

LED Description (See Figure 2)

POWER LED (Green): indicates voltage is present at the power connection of the module.

ALERT LED (Yellow): communicates an abnormal system condition through a unique flash code. The ALERT LED will flash a number of times consecutively, pause and then repeat the process. The number of consecutive flashes, defined as the Flash Code, correlates to a particular abnormal condition. Detailed descriptions of specific ALERT Flash Codes are shown in Table 1 of this manual.

TRIP LED (Red): indicates there is a demand signal from the thermostat but no current to the compressor is detected by the module. The TRIP LED typically indicates the compressor protector is open or may indicate missing supply power to the compressor.

The scroll compressor's run (R), common (C) and start (S) wires are routed through the holes in the Comfort Alert™ module marked "R," "C" and "S." The common (C) wire need not be routed through the module for it to operate properly.

24 VAC Power Wiring — The Comfort Alert™ module requires a constant nominal 24 VAC power supply. The wiring to the module's R and C terminals must be directly from the indoor unit or thermostat. The module cannot be powered by the C terminal on a defrost board or other control board without experiencing nuisance alerts.

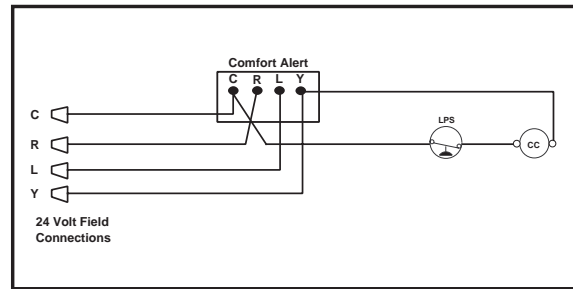

Figure 3. 24VAC Comfort Alert™ Wiring Diagram

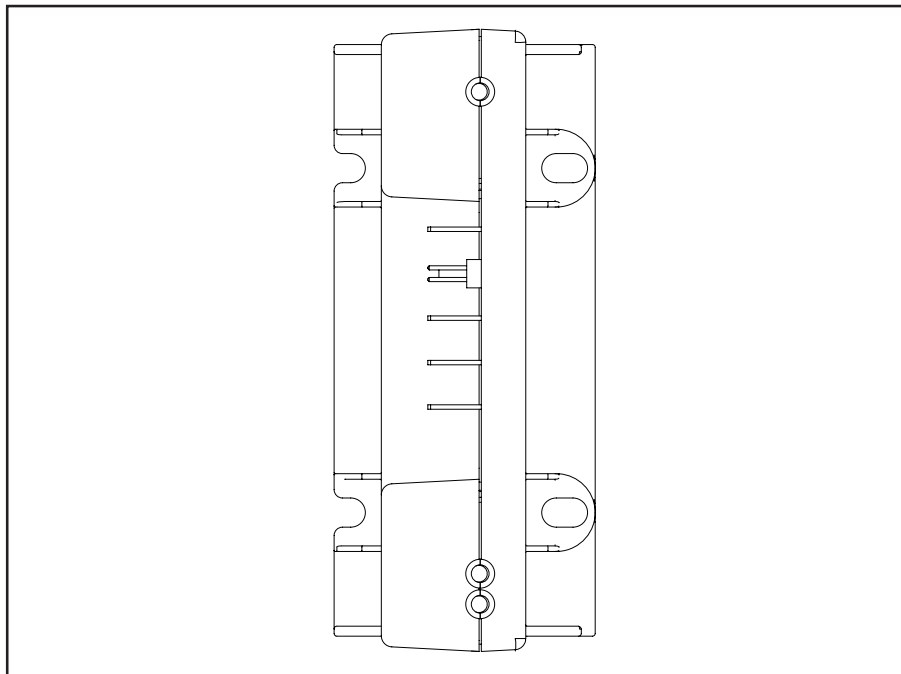

Figure 2. Comfort Alert™ Diagnostics Module

NOTE: Factory installed modules may have different thermostat demand signal wiring, follow manufacturers wiring installations when replacing module.

NOTE: After the thermostat demand signal is connected, verify Y is phased properly with C by measuring 24 VAC across Y and C when demand is present.

TROUBLESHOOTING

Interpreting The Diagnostic LEDs – When an abnormal system condition occurs, the Comfort Alert™ module displays the appropriate ALERT and/or TRIP LED. The yellow alert LED will flash a number of times consecutively, pause and then repeat the process. To identify a Flash Code number, count the number of consecutive flashes. Every time the module powers up, the last ALERT Flash Code that occurred prior to shut down is displayed for one minute.

Cooling — Gradually lower the thermostat temperature setpoint below the actual room temperature and observe that the outdoor unit and indoor blower energize. Feel the air being circulated by the indoor blower and verify that it is cooler than ambient temperature. Listen for any unusual noises. If present, locate and determine the source of the noise and correct as necessary.

Heating — If provided with heating equipment, lower the thermostat setpoint temperature to the lowest obtainable setting and set the thermostat function switch to HEATING. The indoor blower and outdoor unit should stop running. Increase the setpoint temperature of the thermostat to the maximum setting. Verify that the heating equipment has been energized (i.e., fossil fuel burner operating, etc.) and that the indoor blower energizes after a short period of time. Feel the air being circulated by the indoor blower and verify that it is warmer than ambient temperature. Listen for any unusual noises. If present, locate and determine the source of the noise and correct as necessary.

NOTE: Other sources for heating (i.e.: electric furnace, fossil fuel furnace, air handler with electric heat options, etc.) that interface with the unit should be functionally checked to verify

system operation and compatibility. Refer to the installation instructions for this equipment and perform a functional checkout in accordance with the manufacturer's instructions.

Adjustment of Refrigerant Charge:

**CAUTION:**

Split system air conditioner equipment contains liquid and gaseous refrigerant under pressure. Adjustment of refrigerant charge should only be attempted by qualified, trained personnel thoroughly familiar with the equipment. Under no circumstances should the homeowner attempt to install and/or service this equipment. Failure to comply with this warning could result in equipment damage, personal injury, or death.

NOTE: The following Refrigerant Charging Charts are applicable to matched assemblies of our equipment and at listed airflows for the indoor coil. Assemblies of indoor coils and outdoor units not listed are not recommended and deviations from rated airflows or non-listed equipment combinations may require modifications to the expansion device(s) and refrigerant charging procedures for proper and efficient system operation.

Refrigerant Charging Chart — Refer to Refrigerant Charging Charts for correct system charging, and to Orifice Usage Chart for correct restrictor sizes.

NOTE: Linesets over 15 feet in length may require additional refrigerant charge. NORDYNE recommends 0.6 oz. of refrigerant per foot for any lineset over 15 feet.

Optional Equipment — A functional checkout should be performed in accordance with the checkout procedures supplied with the equipment.

Status LED	Status LED Description	Status LED Troubleshooting Information
Green "POWER"	Module has power	Supply voltage is present at module terminals
Red "TRIP"	Thermostat demand signal Y is present, but the compressor is not running	<ol style="list-style-type: none"> 1. Compressor protector is open 2. Outdoor unit power disconnect is open 3. Compressor circuit breaker or fuse(s) is open 4. Broken wire or connector is not making contact 5. Low pressure switch open if present in system 6. Compressor contactor has failed open
Yellow "ALERT" Flash Code 1	Long Run Time Compressor is running extremely long run cycles	<ol style="list-style-type: none"> 1. Low refrigerant charge 2. Evaporator blower is not running 3. Evaporator coil is frozen 4. Faulty metering device 5. Condenser coil is dirty 6. Liquid line restriction (filter drier blocked if present in system) 7. Thermostat is malfunctioning 8. Comfort Alert Failure 9. Comfort Alert Failure
Yellow "ALERT" Flash Code 2	System Pressure Trip Discharge or suction pressure out of limits or compressor overloaded	<ol style="list-style-type: none"> 1. High head pressure 2. Condenser coil poor air circulation (dirty, blocked, damaged) 3. Condenser fan is not running 4. Return air duct has substantial leakage 5. If low pressure switch present in system, check Flash Code 1 information
Yellow "ALERT" Flash Code 3	Short Cycling Compressor is running only briefly	<ol style="list-style-type: none"> 1. Thermostat demand signal is intermittent 2. Time delay relay or control board defective 3. If high pressure switch present go to Flash Code 2 information 4. If low pressure switch present go to Flash Code 1 information
Yellow "ALERT" Flash Code 4	Locked Rotor	<ol style="list-style-type: none"> 1. Run capacitor has failed 2. Low line voltage (contact utility if voltage at disconnect is low) <ul style="list-style-type: none"> • Check wiring connections 3. Excessive liquid refrigerant in compressor 4. Compressor bearings are seized <ul style="list-style-type: none"> • Measure compressor oil level
Yellow "ALERT" Flash Code 5	Open Circuit	<ol style="list-style-type: none"> 1. Outdoor unit power disconnect is open 2. Compressor circuit breaker or fuse(s) is open 3. Compressor contactor has failed open <ul style="list-style-type: none"> • Check compressor contactor wiring and connectors • Check for compressor contactor failure (burned, pitted or open) • Check wiring and connectors between supply and compressor • Check for low pilot voltage at compressor contactor coil 4. High pressure switch is open and requires manual reset 5. Open circuit in compressor supply wiring or connections 6. Unusually long compressor protector reset time due to extreme ambient temperature 7. Compressor windings are damaged <ul style="list-style-type: none"> • Check compressor motor winding resistance
Yellow "ALERT" Flash Code 6	Open Start Circuit Current only in run circuit	<ol style="list-style-type: none"> 1. Run capacitor has failed 2. Open circuit in compressor start wiring or connections <ul style="list-style-type: none"> • Check wiring and connectors between supply and the compressor "S" terminal 3. Compressor start winding is damaged <ul style="list-style-type: none"> • Check compressor motor winding resistance
Yellow "ALERT" Flash Code 7	Open Run Circuit Current only in start circuit	<ol style="list-style-type: none"> 1. Open circuit in compressor run wiring or connections <ul style="list-style-type: none"> • Check wiring and connectors between supply and the compressor "R" terminal 2. Compressor run winding is damaged <ul style="list-style-type: none"> • Check compressor motor winding resistance
Yellow "ALERT" Flash Code 8	Welded Contactor Compressor always runs	<ol style="list-style-type: none"> 1. Compressor contactor has failed closed 2. Thermostat demand signal not connected to module
Yellow "ALERT" Flash Code 9	Low Voltage Control circuit < 17VAC	<ol style="list-style-type: none"> 1. Control circuit transformer is overloaded 2. Low line voltage (contact utility if voltage at disconnect is low) <ul style="list-style-type: none"> • Check wiring connections

- Flash Code number corresponds to a number of LED flashes, followed by a pause and then repeated.
- TRIP and ALERT LEDs flashing at same time means control circuit voltage is too low for operation.

Table 1. Interpreting the Diagnostic LEDs

Miswired Module Indication	Recommended Troubleshooting Action
Green LED is not on, module does not power up	Determine if both R and C module terminals are connected. Verify voltage is present at module's R and C terminals. Review 24VAC Power Wiring (page 4) for R and C wiring.
Green LED intermittent, module powers up only when compressor runs	Determine if R and Y terminals are wired in reverse. Verify module's R and C terminals have a constant source. Review 24VAC Power Wiring (page 4) for R and C wiring.
TRIP LED is on but system and compressor check OK	Verify Y terminal is connected to 24VAC at contactor coil. Verify voltage at contactor coil falls below 0.5VAC when off.
TRIP LED and ALERT LED flashing together	Verify R and C terminals are supplied with 19-28VAC.
ALERT Flash Code 3 (Compressor Short Cycling) displayed incorrectly	Verify Y terminal is connected to 24VAC at contactor coil. Verify voltage at contactor coil falls below 0.5VAC when off.
ALERT Flash Code 5, 6 or 7 (Open Circuit, Open Start Circuit or Open Run Circuit) displayed incorrectly	Check that compressor run and start wires are through module's current sensing holes. Verify Y terminal is connected to 24VAC at contactor coil. Verify voltage at contactor coil falls below 0.5VAC when off.
ALERT Flash Code 6 (Open Start Circuit) displayed for Code 7 (Open Run Circuit) or vice versa	Check that compressor run and start wires are routed through the correct module sensing holes.
ALERT Flash Code 8 (Welded Contactor) displayed incorrectly	Determine if module's Y terminal is connected. Verify Y terminal is connected to 24VAC at contactor coil. Verify 24VAC is present across Y and C when thermostat demand signal is present. If not, R and C are reverse wired. Verify voltage at contactor coil falls below 0.5VAC when off.

Table 2. Module Wiring Troubleshooting

Refrigerant Metering Device for 13 SEER Split System Air Conditioner

Model Number	Restrictor Bore Size (inches)	System Charge R-22 (oz.)
1.5 ton	0.053	78
2.0 ton	0.060	94
2.5 ton	0.065	99
3.0 ton	0.075	110
3.5 ton	0.078	122
4.0 ton	0.089	126
5.0 ton	0.099	160

Restrictor Refrigerant Charging Charts Legend For Cooling Mode of Operation

*Note all pressures are listed in psig. and all temperatures in deg. °F.



- Shaded Boxes indicate flooded conditions



- Rated Design Values. Suction Pressure will be lower than design value if indoor air flow, entering dry bulb, or entering wet bulb temperatures are lower than design.

- Discharge temperatures greater than charted values indicates a refrigerant undercharge.

Restrictor Refrigerant Charging Charts

1.5 TON	OUTDOOR TEMPERATURE (°F)																
	70		75		80		85		90		95		100		105		
	Suct. Press.	Liq. Press.	Dis. Temp.	Liq. Press.	Dis. Temp.	Liq. Press.	Dis. Temp.	Liq. Press.	Dis. Temp.	Liq. Press.	Dis. Temp.	Liq. Press.	Dis. Temp.	Liq. Press.	Dis. Temp.	Liq. Press.	Dis. Temp.
74	156	119															
76	159	124	173	126													
78	161	130	175	131	190	133											
80	161	139	177	136	192	138	206	139									
82	165	142	178	143	194	142	208	144	223	145							
84			182	146	195	148	211	148	225	150	239	151					
86					199	151	213	153	227	154	241	156	256	157			
88							216	157	230	158	243	160	258	161	272	163	
90							220	160	233	162	247	164	260	165	274	166	
92									237	166	250	168	264	169	276	170	
94											254	172	267	174	281	175	
96													271	178	284	180	
98															288	184	
100																	

2 TON	OUTDOOR TEMPERATURE (°F)																
	70		75		80		85		90		95		100		105		
	Suct. Press.	Liq. Press.	Dis. Temp.	Liq. Press.	Dis. Temp.	Liq. Press.	Dis. Temp.	Liq. Press.	Dis. Temp.	Liq. Press.	Dis. Temp.	Liq. Press.	Dis. Temp.	Liq. Press.	Dis. Temp.	Liq. Press.	Dis. Temp.
72	154	136															
74	156	141	170	140													
76	158	147	172	145	187	145											
78	162	150	175	150	189	150	203	149									
80	165	152	178	154	191	154	205	154	219	153							
82			181	157	194	158	207	158	222	158	236	158					
84					198	161	211	162	224	162	238	162	252	162			
86							214	166	227	166	240	166	254	166	269	166	
88							218	169	230	170	243	170	256	170	271	170	
90									234	174	247	174	260	174	273	174	
92											250	178	263	178	276	178	
94													266	183	279	183	
96															283	187	
98																	

Restrictor Refrigerant Charging Charts

2.5 TON	OUTDOOR TEMPERATURE (°F)																	
	70		75		80		85		90		95		100		105			
Suct. Press.	Liq. Press.	Dis. Temp.	Liq. Press.	Dis. Temp.	Liq. Press.	Dis. Temp.	Liq. Press.	Dis. Temp.	Liq. Press.	Dis. Temp.	Liq. Press.	Dis. Temp.	Liq. Press.	Dis. Temp.	Liq. Press.	Dis. Temp.		
72	159	134																
74	161	139	175	138														
76	163	144	178	143	192	143												
78	166	149	180	148	194	147	208	147										
80	169	152	182	153	196	152	211	152	225	151								
82			186	156	199	156	213	156	227	156	242	156						
84					203	160	216	160	229	160	244	160	258	160				
86									219	164	232	164	246	164	260	164	274	164
88									223	167	236	168	249	168	262	168	276	167
90											239	172	252	172	266	172	278	171
92													256	176	269	176	282	176
94															273	181	286	180
96																	289	185
98																		

3 TON	OUTDOOR TEMPERATURE (°F)																	
	70		75		80		85		90		95		100		105			
Suct. Press.	Liq. Press.	Dis. Temp.	Liq. Press.	Dis. Temp.	Liq. Press.	Dis. Temp.	Liq. Press.	Dis. Temp.	Liq. Press.	Dis. Temp.	Liq. Press.	Dis. Temp.	Liq. Press.	Dis. Temp.	Liq. Press.	Dis. Temp.		
74	156	139																
76	158	145	172	143														
78	161	150	175	148	189	147												
80	163	154	177	153	191	151	205	150										
82	167	157	180	157	193	156	207	155	221	154								
84			183	160	196	160	209	159	223	158	237	157						
86					200	163	212	163	225	162	239	161	253	160				
88									216	167	229	166	241	165	256	164	270	163
90									219	170	232	170	245	169	258	168	272	167
92											235	174	248	173	261	173	274	171
94													252	178	265	177	277	176
96															268	181	281	180
98																	284	185
100																		

3.5 TON	OUTDOOR TEMPERATURE (°F)																	
	70		75		80		85		90		95		100		105			
Suct. Press.	Liq. Press.	Dis. Temp.	Liq. Press.	Dis. Temp.	Liq. Press.	Dis. Temp.	Liq. Press.	Dis. Temp.	Liq. Press.	Dis. Temp.	Liq. Press.	Dis. Temp.	Liq. Press.	Dis. Temp.	Liq. Press.	Dis. Temp.		
73	174	138																
75	176	143	186	142														
77	178	149	188	147	198	146												
79	181	153	190	152	200	151	210	150										
81	185	156	193	156	202	156	212	155	222	154								
83			197	159	205	160	214	159	224	158	234	158						
85					209	163	217	163	226	163	236	162	246	162				
87									221	167	229	167	238	166	248	166	258	165
89									224	170	233	171	242	170	250	170	260	169
91											236	174	245	174	254	174	262	173
93													248	178	257	178	266	177
95															260	182	269	182
97																	272	186
99																		

Restrictor Refrigerant Charging Charts

4 TON	OUTDOOR TEMPERATURE (°F)															
	70			75		80		85		90		95		100		105
Suct. Press.	Liq. Press.	Dis. Temp.	Liq. Press.	Dis. Temp.	Liq. Press.	Dis. Temp.	Liq. Press.	Dis. Temp.	Liq. Press.	Dis. Temp.	Liq. Press.	Dis. Temp.	Liq. Press.	Dis. Temp.	Liq. Press.	Dis. Temp.
72	150	125														
74	153	130	167	131												
76	155	135	169	136	184	138										
78	155	144	171	141	186	143	200	144								
80	159	147	172	148	188	148	202	149	217	151						
82			176	151	190	153	204	154	219	155	233	157				
84					193	156	207	158	221	159	235	161	249	162		
86							210	162	224	164	237	165	251	166	266	168
88							213	165	227	167	241	169	253	170	268	172
90									230	171	244	173	257	175	270	176
92											247	177	261	179	274	181
94													264	183	278	185
96															281	190
98																

5 TON	OUTDOOR TEMPERATURE (°F)															
	70			75		80		85		90		95		100		105
Suct. Press.	Liq. Press.	Dis. Temp.	Liq. Press.	Dis. Temp.	Liq. Press.	Dis. Temp.	Liq. Press.	Dis. Temp.	Liq. Press.	Dis. Temp.	Liq. Press.	Dis. Temp.	Liq. Press.	Dis. Temp.	Liq. Press.	Dis. Temp.
68	149	141														
70	151	146	166	146												
72	154	151	168	151	183	151										
74	154	160	171	156	185	156	200	156								
76	158	163	172	163	187	161	202	160	217	160						
78			175	166	189	166	204	165	219	165	234	165				
80					193	169	207	170	221	169	236	169	251	169		
82							210	173	224	173	238	173	253	173	267	173
84							213	177	227	177	241	177	255	177	269	177
86									231	181	245	181	259	181	271	180
88											248	185	262	186	276	185
90													265	190	279	190
92															283	194
94																

TXV Refrigerant Charging Charts

1.5 Ton AC TXV Charging Chart

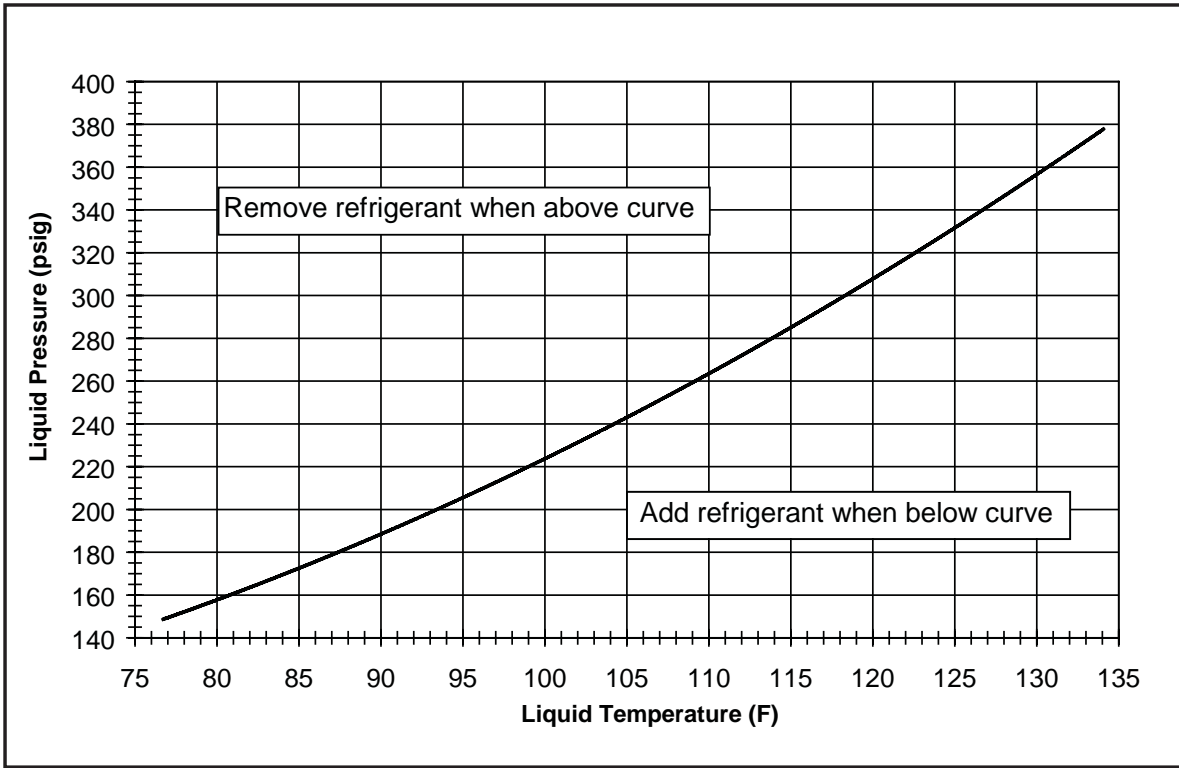

2.0 Ton AC TXV Charging Chart

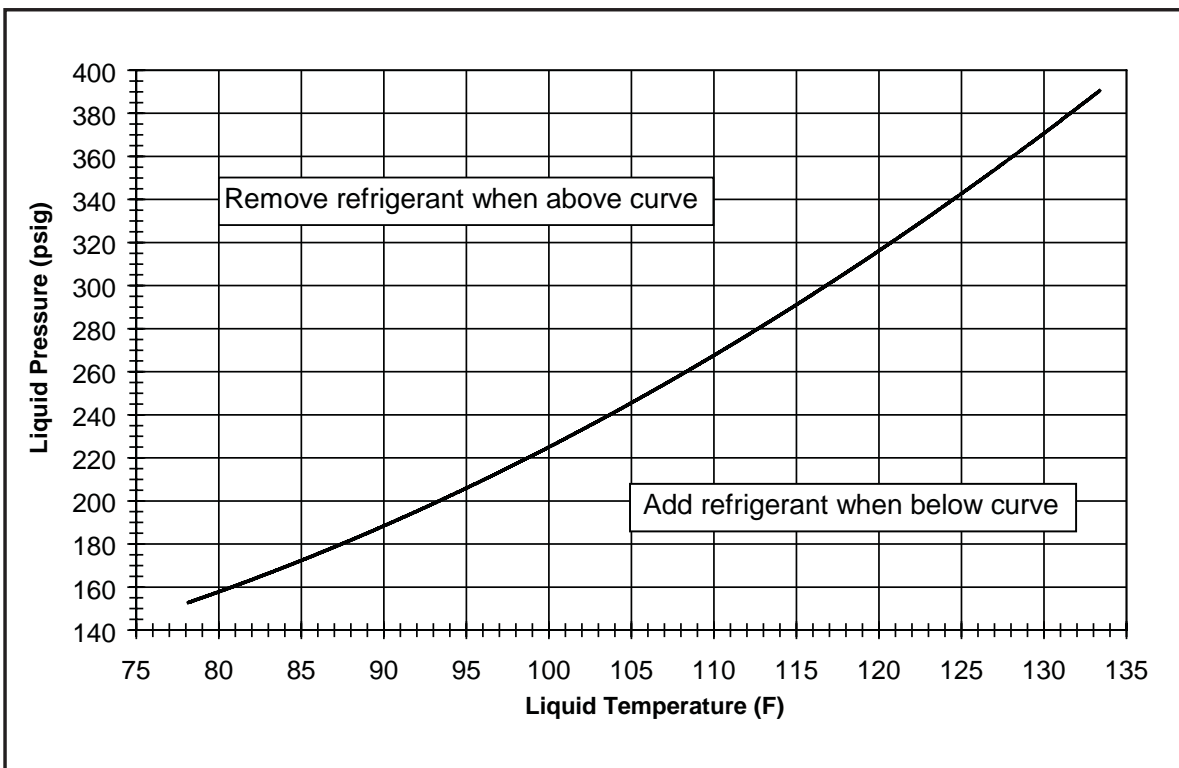

TXV Refrigerant Charging Charts

2.5 Ton AC TXV Charging Chart

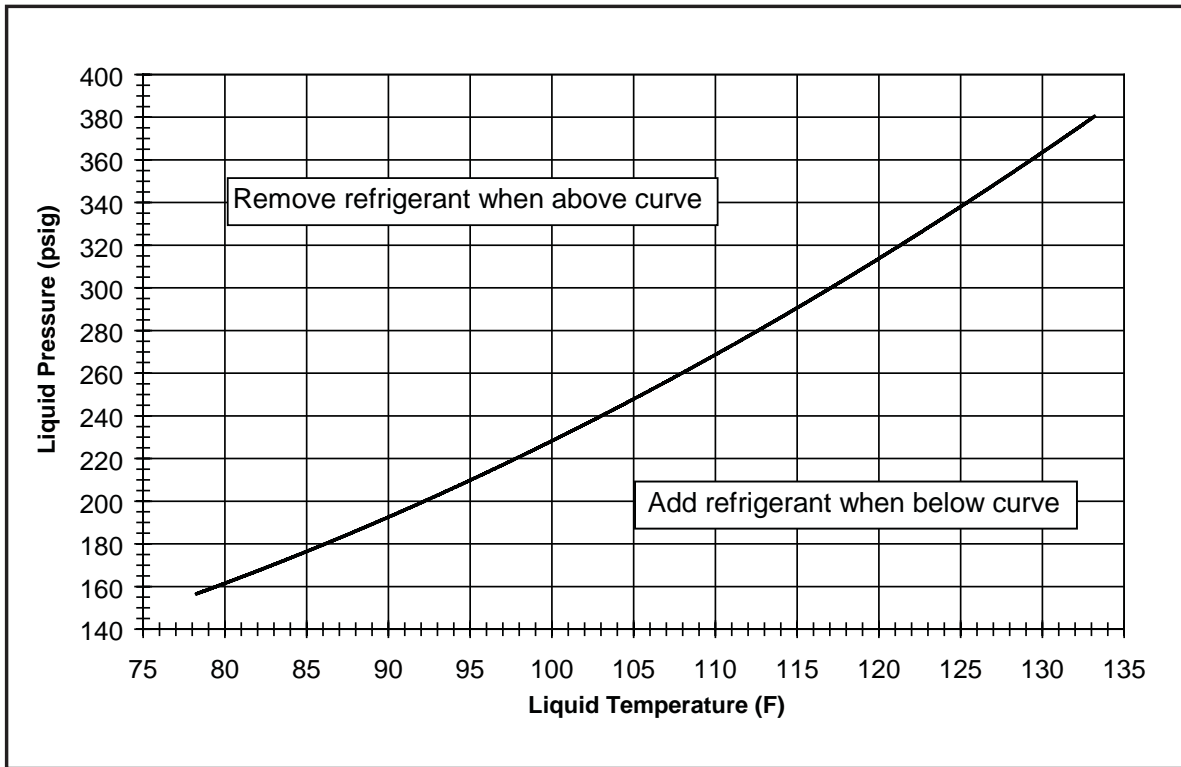

3.0 Ton AC TXV Charging Chart

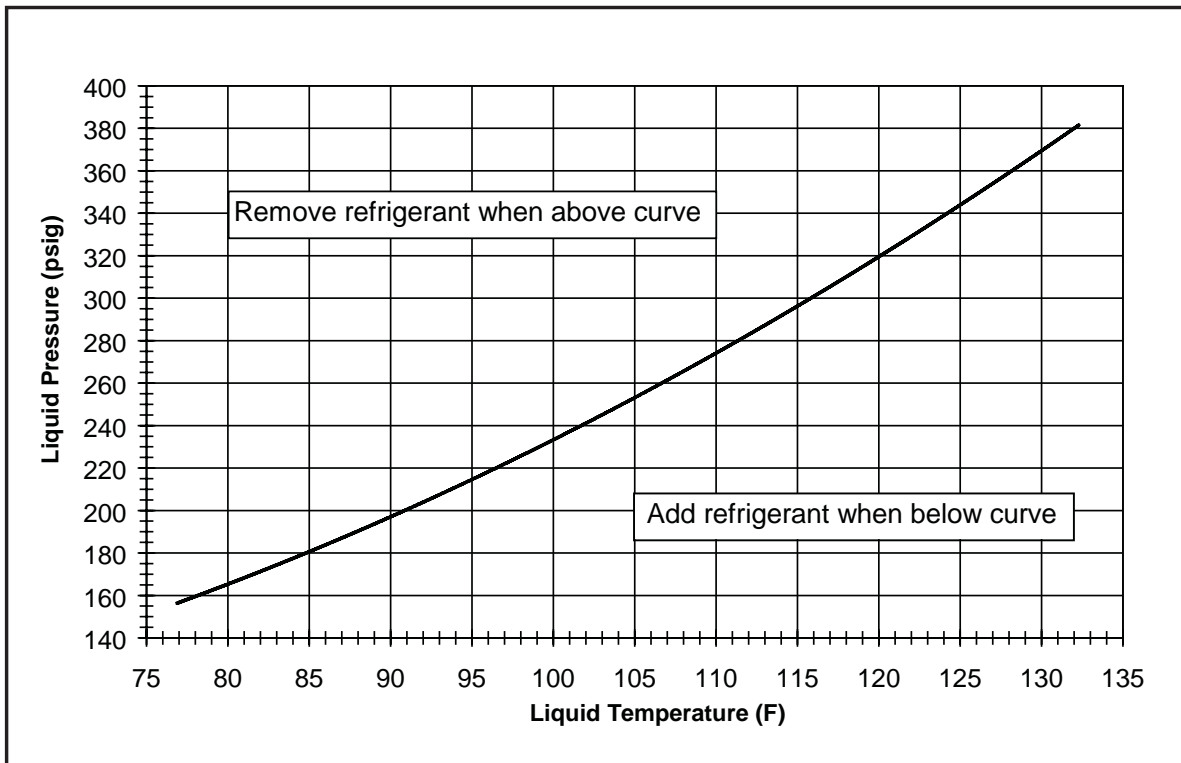

TXV Refrigerant Charging Charts

3.5 Ton AC TXV Charging Chart

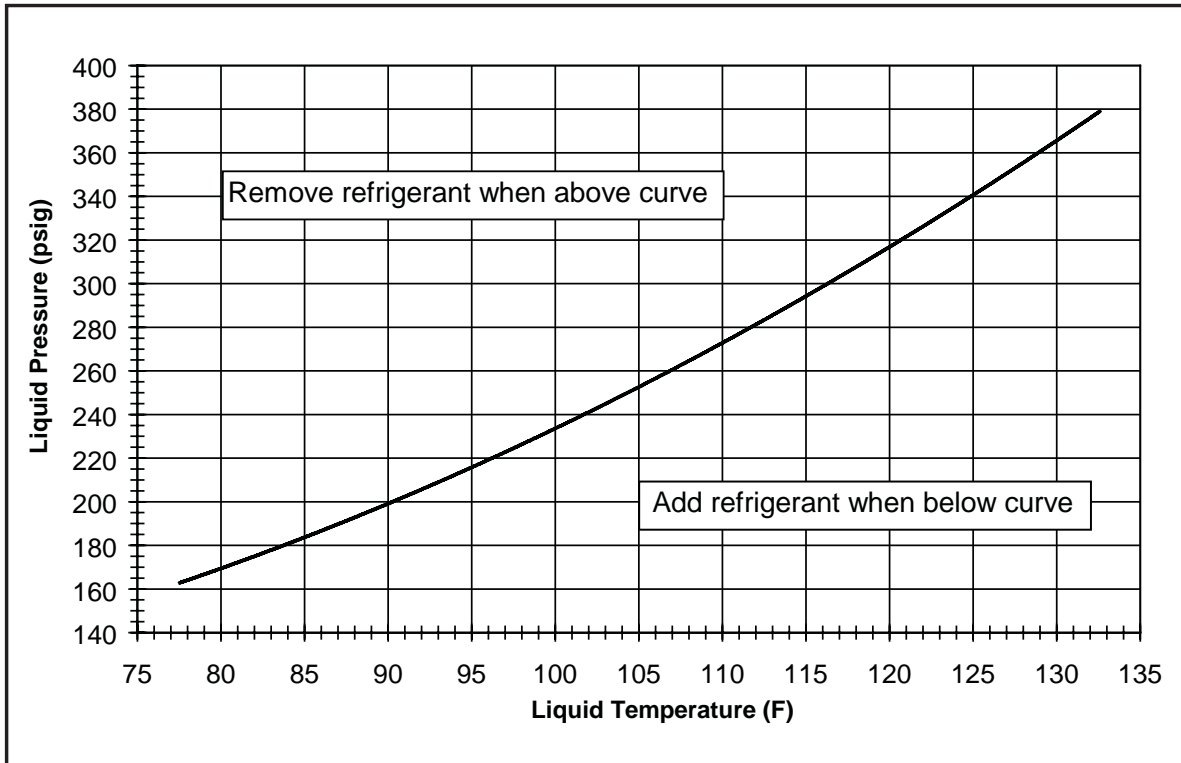

4.0 Ton AC TXV Charging Chart

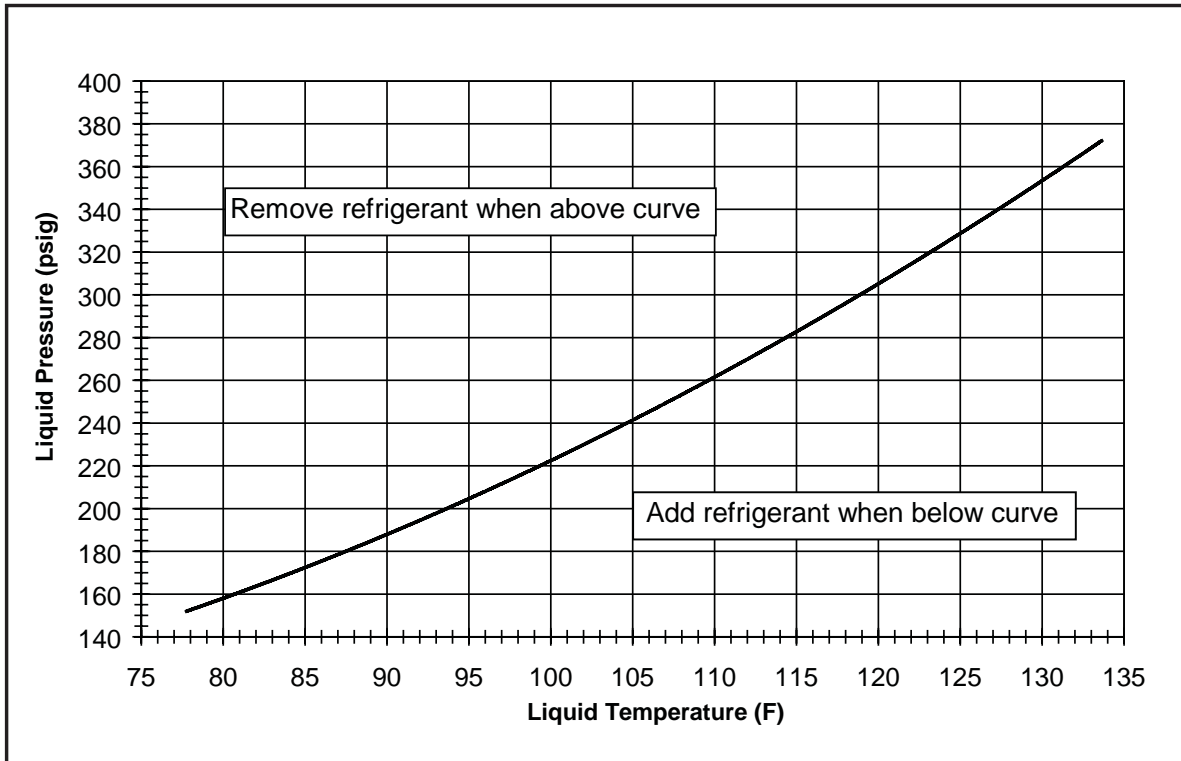

TXV Refrigerant Charging Charts

5.0 Ton AC TXV Charging Chart

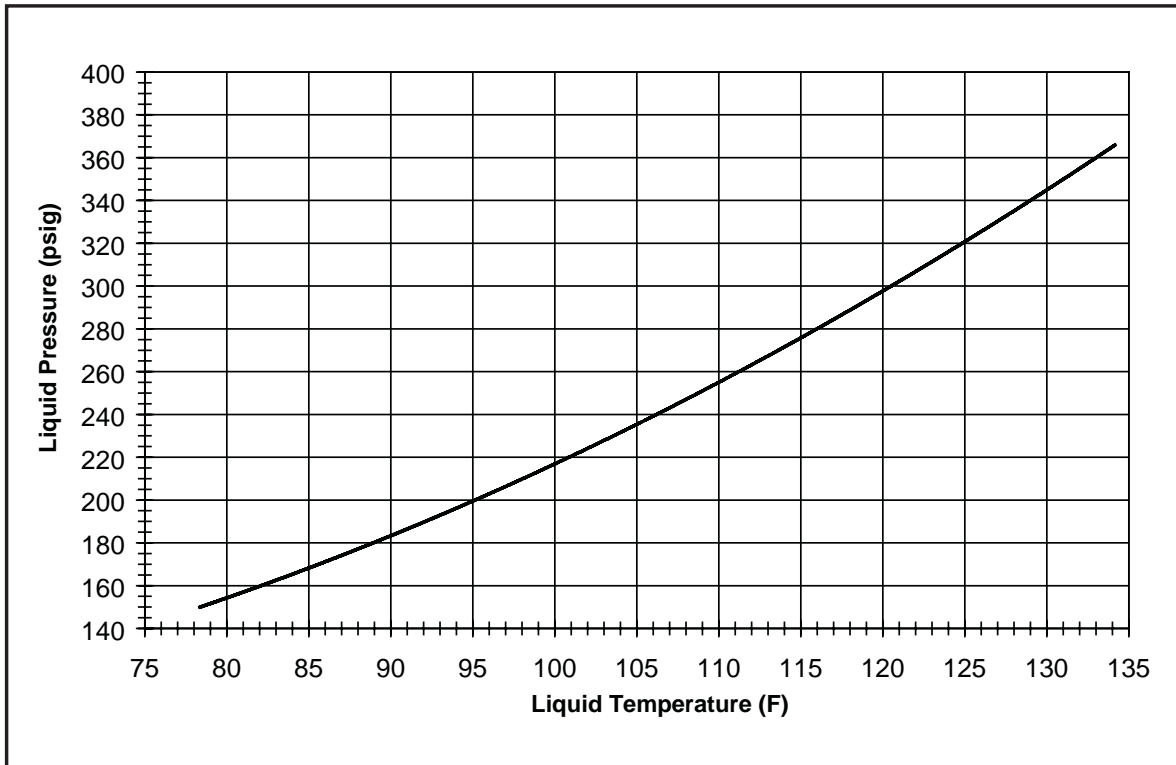

**INSTALLER: PLEASE LEAVE
THESE INSTALLATION INSTRUCTIONS
WITH THE HOMEOWNER.**



7085600

7085600

Specifications and illustrations subject to change without notice and without incurring obligations. Printed in U.S.A. (06/06)