

13 SEER Single Package Heat Pump

Installation Instructions

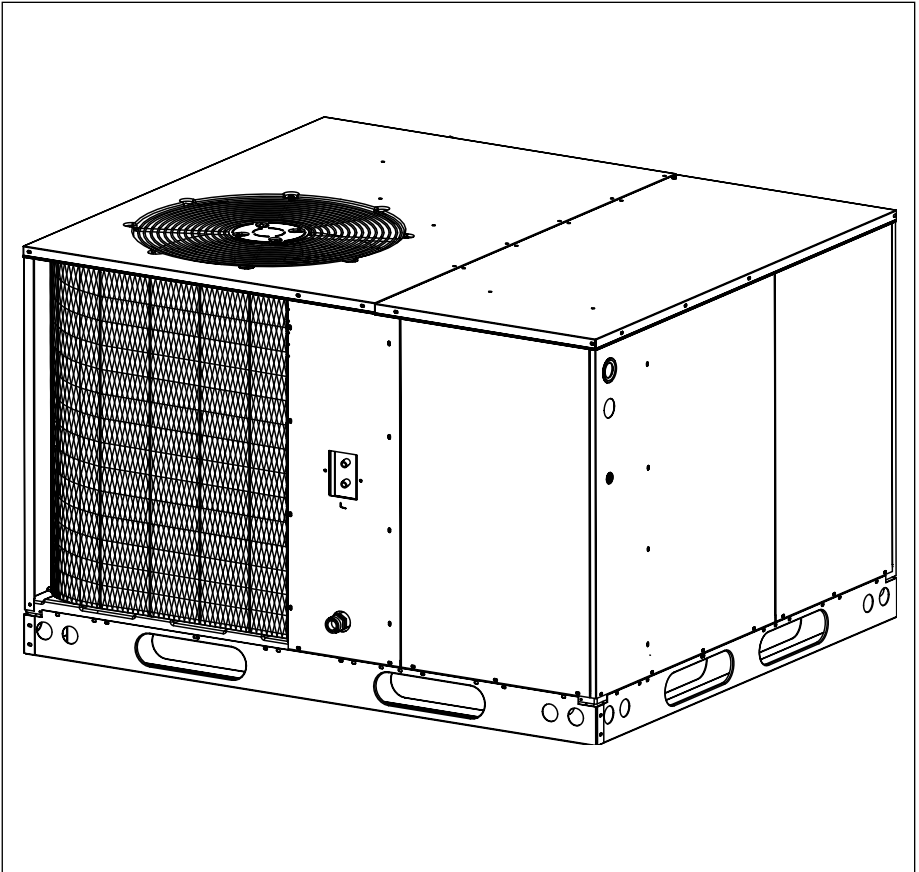

IMPORTANT

These instructions are primarily intended to assist qualified individuals experienced in the proper installation of heating and/or air conditioning appliances. Some local codes require licensed installation/service personnel for this type equipment. All installations must be in accordance with these instructions and with all applicable national and local codes and standards.

Read these instructions thoroughly before starting the installation. Follow all precautions and warnings contained within these instructions and on the unit.

SECTION 1. OWNER INFORMATION

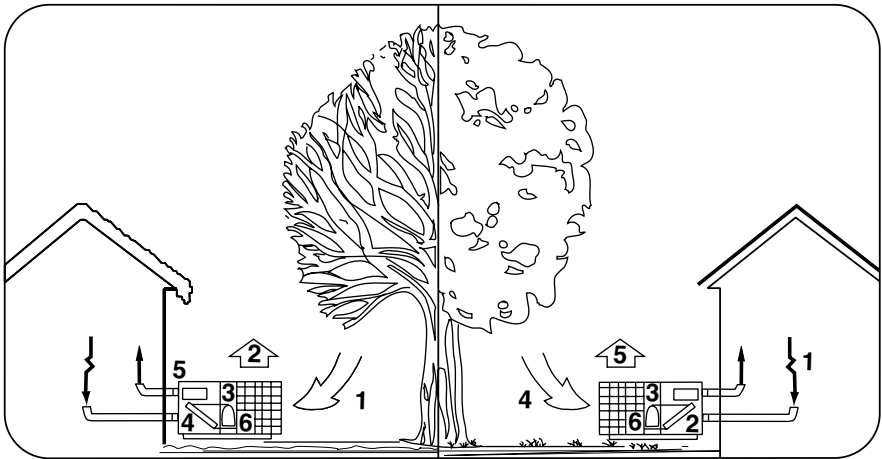

WINTER HEATING

SUMMER COOLING

1. Outdoor air enters the heat pump.
2. The cold, heat-transfer section (outdoor coil) extracts the heat from the air as the refrigerant evaporates from a liquid to a cold gas.
3. The refrigerant, compressed to a hot gas by the heat pump, carries the heat to the heat-transfer section (indoor coil).
4. The hot, heat-transfer section (indoor coil) releases the heat as the refrigerant condenses from a gas to a liquid.
5. The blower circulates the heat throughout the home via the supply duct.
6. The refrigerant returns to the outdoor coil and evaporates once again to absorb more heat.

1. Indoor air enters the return air duct.
2. The cold, heat-transfer section (indoor coil) extracts the heat from the air as the refrigerant evaporates from a liquid to a cold gas.
3. The refrigerant, drawn to the heat pump and compressed to a hot gas, carries the heat outdoors.
4. The hot, heat-transfer section (outdoor coil) releases the heat as the refrigerant condenses from a gas to a liquid.
5. The heat pump (outdoor fan) discharges the heat to the outside air.
6. The refrigerant returns to the indoor coil and evaporates once again to absorb more heat.

It is the sole responsibility of the homeowner to make certain that heat pump has been correctly set up and adjusted to operate properly.

The Manufacturer warrants the heat pump to be free from defects in material or workmanship for a period of one year. We will not be responsible for any costs found necessary to correct problems due to improper setup, improper installation, adjustments, improper operating procedure on the part of the user, etc.

Some specific examples of service calls which are not included in the limited warranty are:

1. Correcting wiring problems in the electrical circuit supplying the heat pump.
2. Resetting circuit breakers or other switches.

3. Adjusting or calibrating of thermostat.

To avoid misunderstandings at a later date, carefully review these responsibilities with your dealer or service company.

The heat pump system will heat and cool your home and save your energy dollars.

During the summer, a heat pump cools a house by absorbing heat from within the house and exhausting it outdoors. During the winter, a heat pump heats a house by absorbing heat outdoors and exhausting it indoors. This is an efficient heating means because you pay for "moving" heat from outdoors to indoors, but do not pay to generate the heat.

OPERATING INSTRUCTIONS

To Operate Your Heat Pump For Cooling —

1. Set the thermostat system switch to COOL and the thermostat fan switch to AUTO. See Figure 1.
2. Set the thermostat temperature selector to the desired cooling temperature. The outdoor unit fan, the indoor blower, and the compressor will all cycle on and off to maintain the indoor temperature at the desired cooling level.

NOTE: If the thermostat temperature level is re-adjusted, or if the thermostat system switch is re-positioned, the outdoor unit fan and the compressor may not start immediately. A protective timer circuit holds the compressor and the outdoor fan off for approximately six minutes following a previous operation or the interruption of the main electric power.

To Operate Your Heat Pump For Heating —

1. Set the thermostat system switch for HEAT and the thermostat fan switch to AUTO. See Figure 1.
2. Set the thermostat temperature selector to the desired heating temperature. The outdoor unit fan, the indoor blower, and the compressor will all cycle on and off to maintain the indoor temperature at the desired heating level.

NOTE: If the thermostat temperature level is re-adjusted, or if the thermostat system switch is re-positioned, the outdoor unit fan and the compressor may not start immediately. A protective timer circuit holds the compressor and the outdoor fan off for approximately six minutes following a previous operation or the interruption of the main electrical power.

Emergency Heat — Some thermostats will include a system switch position termed EM HT or AUX HT, etc. This is a back-up heating mode to be used only if there is a suspected problem. With the system switch set to EM HT, etc., the compressor and outdoor fan will be locked off and supplemental heat (electric resistance heating) will be used as a source of heat. Sustained use of electric resistance heat in place of the heat pump will result in an increase in electric utility costs.

Defrost — During cold weather heating operation, the outdoor unit will develop a coating of snow and ice on the heat transfer coil. This is normal and the unit will periodically defrost itself. During the defrost cycle, the outdoor fan

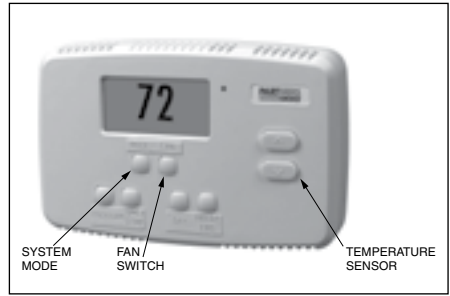

Figure 1. Typical Thermostat

will stop, while the compressor continues to run and heat the outdoor coil, causing the snow and ice to melt. During defrost, there may be some steam rise from the outdoor unit as the warm coil causes some melted frost to evaporate.

SPECIFICATIONS

Single Package Heat Pumps are designed for outdoor rooftop or ground level slab installations. The units are shipped ready for horizontal duct connections and are easily converted for down flow applications.

All models are shipped from the factory with the following:

1. Zero clearance to combustibles
2. Multi-speed direct-drive blower.
3. Compressor Anti-short-cycle timer for single phase models.
4. Blower Speed Relay.
5. Horizontal or Down flow duct connections.

The unit dimensions are shown in Figure 3.

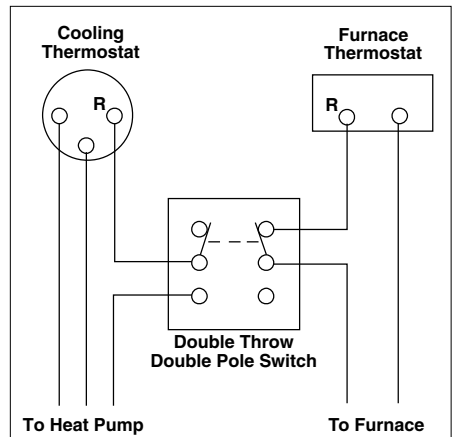

Figure 2. Thermostat Interlock System

Optional field-installed electric heater kits are available in 5 kw through 20 kw heating capacities. A separate installation instruction document for the electric heaters and their application accompanies this one. A two stage heat 24VAC thermostat should be used with electric heater kits installed.

SAFETY CONSIDERATIONS

It is the responsibility of the installer to ensure that the installation is made in accordance with all applicable local and national codes.



WARNING:

Improper installation, service, adjustment, or maintenance may cause explosion, fire, electrical shock or other hazardous conditions which may result in personal injury or property damage. Unless otherwise noted in these instructions, only factory authorized kits or accessories may be used with this product. Noncompliance may void the unit's warranty.

Labels, Tags — When working with this equipment, follow all precautions in the literature, on tags, and on labels provided with the unit and/or approved field installed kits. The type of hazard and severity are described on each label or tag.

Pressures Within The System — This equipment contains liquid and gaseous refrigerant under high pressure. Installation or servicing should only be performed by qualified trained personnel thoroughly familiar with this type equipment.

INSTALLATION REQUIREMENTS

Equipment Check — Before beginning the installation, verify that the unit model is correct for the job. The unit model number is printed on the data label. All units have been securely packaged at the point of shipment. After unpacking the unit, carefully inspect it for apparent and concealed damage. Claims for damage should be filed with the carrier by the consignee.

Requirements and Codes — The installer must comply with all local codes and regulations which govern this type equipment. Local codes

and regulations take precedence over any recommendations contained in these instructions. All electrical wiring must be made in accordance with local codes and regulations and with the National Electric Code (ANSI/NFPA 70) or in Canada the Canadian Electric Code Part 1 CSA C.22.1. Air Ducts must be installed in accordance with the standards of the National Fire Protection Association "Standards for Installation of Air Conditioning and Ventilation Systems" (NFPA 90A), "Standard for Installation of Residence Type Warm Air Heating and Air Conditioning Systems" (NFPA 90B), these instructions and all applicable local codes.

NFPA publications are available by writing:

National Fire Protection Association
Batterymarch Park
Quincy, Maine 02269

Unit Location — This heat pump is designed only for outdoor installations. Choosing the location of the unit should be based on minimizing the length of the supply and return ducts. Consideration should also be given to availability of electric power, service access, noise, and shade. Sufficient clearance for unobstructed airflow through the outdoor coil must be maintained in order to achieve rated performance **See Figure 4** for minimum clearances to obstructions.

Air Filters — A suitable air filter must be installed in the return air system. Air filter pressure drop must not exceed 0.08 inches w.c. at 300 fpm.

Condensate Drain — Condensate is removed from the unit through the 3/4" female pipe fitting located on the front side of the unit. **See Figure 5.** Install a 2 inch condensate trap in the drain line of the same size and prime with water. When connecting rigid drain line, hold the female fitting with a wrench to prevent twisting. **Do not over tighten!** Refer to local codes and restrictions for proper condensate disposal requirements.

UNIT INSTALLATION

Ground Level — When installing the unit at ground level, provide a concrete mounting pad separate from the building foundation. The pad must be level to insure proper condensate disposal and strong enough to support the unit's weight. Refer to **Figure 3.** Make sure the slab is a minimum of 2" above the grade and in an area that drains well. **See Figure 6.**

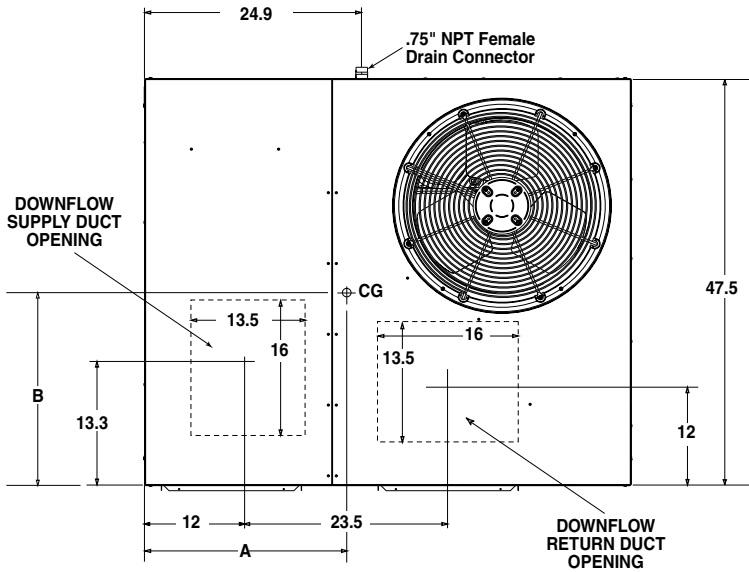

Top View

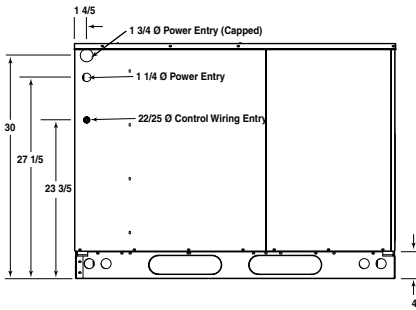

Side View

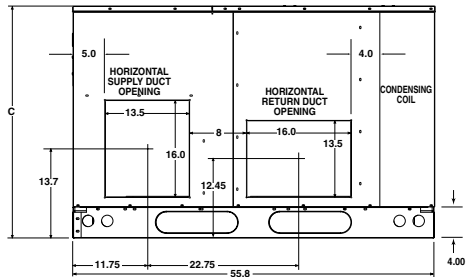

Back View

Model Number Q4SD-PPH1SD	Unit Weight	Center of Gravity		Height (in inches)	
		A	B	C	
				with base rails	without base rails
X24	450	28.0	25.5	39.0	35.3
X30	455	28.0	25.5	39.0	35.3
X36	460	28.0	25.5	39.0	35.3
X42	565	29.5	26.0	43.0	39.3
X48	570	29.5	26.0	43.0	39.3
X60	580	29.5	26.0	43.0	39.3

Figure 3. Dimensions

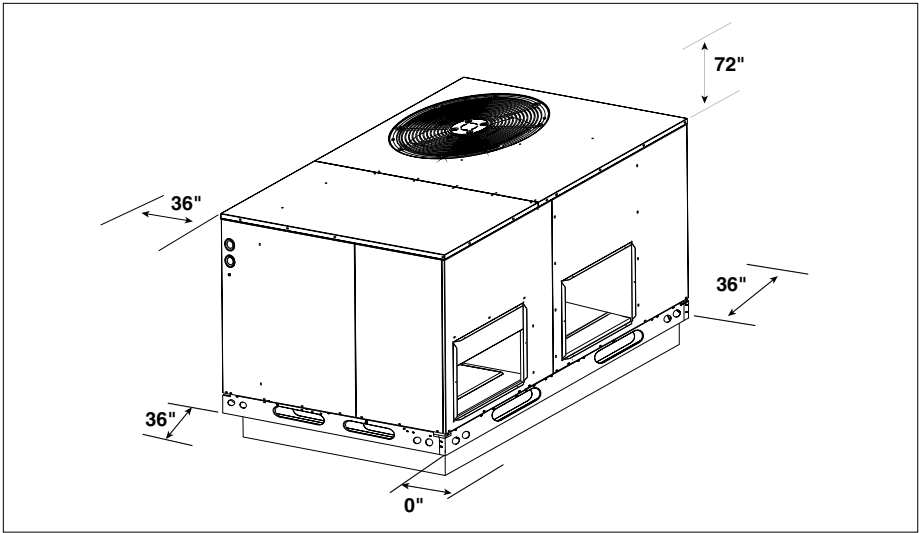

Figure 4. Minimum Clearances

Rigging and Hoisting— The unit should be lifted using slings and spreader bars. The spreader bars are necessary to prevent damaging the top of the unit's cabinet. Make sure that the lifting equipment is adequate for the load. Refer to **Figure 3** for unit weights. Keep the unit in an upright position at all times. **For rooftop installations, remove and discard the two supports attached beneath the unit.**

! WARNING:

To avoid the risk of property damage or personal injury; it is the rigger's responsibility to insure that whatever means are used to hoist the unit are safe and adequate.

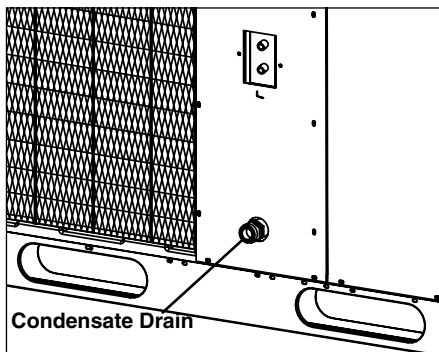

Figure 5. Condensate Drain

! CAUTION:

All panels must be securely in place when rigging and hoisting.

The rigging must be located outside the unit's center of gravity. Refer to **Figure 3** for center of gravity locations.

Rooftop — For rooftop installations use the appropriate accessory roof curb and follow all instructions included with it. Make sure the two supports beneath the unit have been removed. Locate the unit according to local building codes and ordinances. The curb must be level to insure proper condensate drainage. **See Figure 7.**

The roof must be capable of handling the weight of the unit. **See Figure 3** for unit weights. Reinforce the roof if required.

AIR DUCTS

This unit is designed only for use with a supply and return duct. Air ducts should be installed in accordance with the standards of the National Fire Protection Association "Standard for Installation of Air Conditioning Systems" (NFPA 90A), "Standard for Installation of Residence Type Warm Air Heating and Air Conditioning Systems" (NFPA 90B), and all applicable local codes.

Design the duct work according to methods described by the National Warm Air Heating

and Air Conditioning Association (ACCA). The ducts must be properly sized not to exceed .2" w.c. pressure drop at 400 scfm per nominal ton of cooling capacity.

Duct work should be attached directly to the unit flanges for horizontal applications. On roof curb installations the ducts must be attached to the curb hangers, not the unit.

Unconditioned Spaces — All duct work passing through unconditioned space must be properly insulated to minimize duct losses and prevent condensation. Use insulation with an outer vapor barrier. Refer to local codes for insulation material requirements.

Acoustical Duct Work — Certain installations may require the use of acoustical lining inside the supply duct work. Acoustical insulation must be in accordance with the current revision of the Sheet Metal and Air Conditioning Contractors National Association (SMACNA) application standard for duct liners. Duct lining must be UL classified batts or blankets with a fire hazard classification of FHC-25/50 or less. Fiber duct work may be used in place of internal duct liners if the fiber duct work is in accordance with the current revision of the SMACNA construction standard on fibrous glass ducts. Fibrous duct work and internal acoustical lining must be NFPA Class 1 air ducts when tested per UL Standard 181 for Class 1 ducts.

Horizontal to Down flow Conversion — The unit is shipped ready for horizontal duct connections. If down flow ducts are required, the unit must be converted following the steps below for both the supply and return ducts.

- 1) Remove the horizontal duct cap.
- 2) Locate the duct cap inside the duct openings and remove the screw holding it in place.

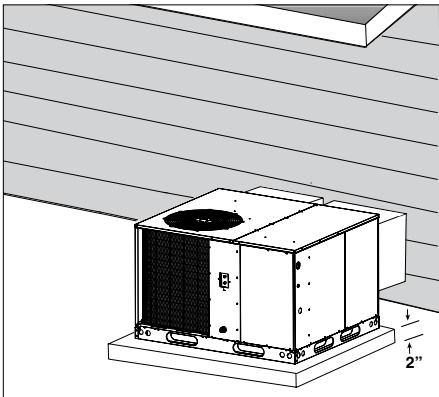

Figure 6. Ground Level Installation

- 3) Lift the cap out of the unit. (The cap can be pushed up from the bottom by reaching through the fork slot).
- 4) Cover the horizontal duct opening with the horizontal duct cap. The insulation will be on the indoor side.
- 5) Fasten the cover with screws to seal.

Clearance — These units are approved for 0 inch clearance.

ELECTRICAL WIRING

General — Electrical power wiring must be made in accordance with all applicable local codes and ordinances, and with the current revision of the National Electric Code NFPA 70 or in Canada CSA C.22.1 - Canadian Electrical Code Part 1. If any of the original wire as supplied with the unit must be replaced, it must be replaced with material of the same gage and temperature rating.

WARNING:

To avoid the risk of electrical shock, personal injury, or death, disconnect all electrical power to the unit before performing any maintenance or service. The unit may have more than one electrical power supply.

Line Voltage — Before proceeding with the electrical connections, make certain that the voltage, frequency, and phase of the supply source are the same as those specified on the unit rating plate. Also verify that the service provided by the utility is sufficient to handle the additional load imposed by this equipment.

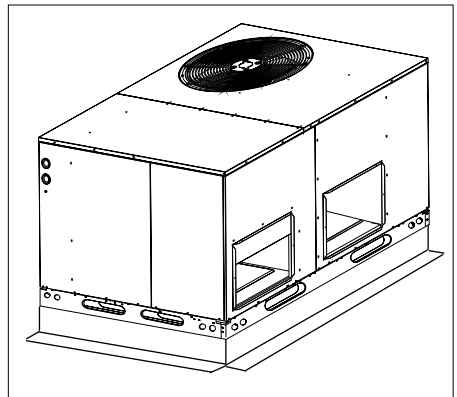

Figure 7. Roof Top Installation

See the unit wiring label for proper high and low voltage wiring. Make all electrical connections in accordance with all applicable codes and ordinances.

Use a separate branch electrical circuit for this unit. A means of electrical disconnect must be located within sight of and readily accessibility to the unit. Internally mounted circuit breakers are available as field installed options. These circuit breakers can be used as an electrical disconnect.

The unit is shipped from the factory wired for 240 volt transformer operation. For 208 volt operation, remove the lead from the transformer terminal marked 240V and connect it to the terminal marked 208V. For maximum ampacity and over current protection, see the unit rating plate.

Provide power supply (or supplies) for the unit in accordance with the unit wiring diagram, and the unit rating plate. Connect the line-voltage leads to the corresponding terminals on the contactor (or the circuit breaker when the field installed circuit breaker kits are used) inside the control compartment. Use only copper wire for the line voltage power supply to this unit. Use proper code agency listed conduit and a conduit connector for connecting the supply wires to the unit and for obtaining proper grounding. Grounding may also be accomplished by using the grounding lug provided in the control box.

 **WARNING:**

The unit cabinet must have and uninterrupted or unbroken electrical ground to minimize personal injury if an electrical fault should occur. This ground may consist of electrical wire or approved conduit when installed in accordance with existing national or local codes.

Selecting Proper Airflow for Variable Speed Units—Variable speed packaged heat pump units are equipped with a microprocessor-controlled variable speed motor that is pre-programmed to deliver optimum airflow in a variety of conditions and system configurations. The packaged heat pump units respond directly to the thermostat inputs, as well as the optional humidistat (Page 11) (if installed) and bonnet switch (Page 11) (if installed). During normal operation, the motor will gradually change speeds during start-up, shut down, when thermostat inputs change, and when

the duct static pressure changes (vents closed or opened, filter clogging, etc.). The packaged heat pump unit is configured by setting the selector switches and removing jumper connectors as directed below. **IMPORTANT! This packaged heat pump unit has been designed to give the installer maximum flexibility to optimize system performance, efficiency, and comfort. Because there are so many different ways to set up the packaged heat pump unit it is important to read and follow these directions carefully.**

Selecting the Basic Cooling/Heat Pump Airflow—The basic cooling/heat-pump airflow is selected by setting switches 1 through 4 on the thermostat input board located on the blower. All airflows for other modes of operation (except electric heat) are determined by this basic setting.

Table 1 shows the basic airflow values versus the airflow selector switch settings. Table 1 also shows the range of basic airflow settings recommended for each nominal system capacity.

NOTE: The CFM values listed in the tables are not dependent on duct static pressure. The motor automatically compensates for changes in duct static pressure (within the limits of the motor).

For maximum capacity and energy efficiency, select an airflow at or near the top of the range for that nominal capacity. For maximum dehumidification, select an airflow near the middle or bottom of the range for that nominal capacity. Additional information on humidity control can be found in the sections labeled “Humidistat” and “Delay Setting”.

NOTE: If coil icing is observed, the basic cooling/heat-pump airflow selected may be too low. Double-check to be sure the setting selected is within the range shown in Table 1. Also check to be sure the system is properly charged (see charging charts). If icing continues to occur, raise the selected airflow one or two steps.

When operating in the heat pump mode, a higher basic airflow setting will increase the energy efficiency and capacity but will also decrease the supply air temperature. The optional Bonnet Control Switch may be added to increase the supply air temperature in the heat-pump mode when the supply air temperature is below a comfortable level. For more details see the section labeled “Bonnet Control Switch”.

Basic Air-Flow Setting

1/2 HP Motor

CFM	Switch Number				Nominal Capacity		
	1	2	3	4	2.0	2.5	3.0
490	0	0	0	1			
575	0	0	0	0			
660	0	0	1	0			
770	1	0	0	1			
860	1	0	0	0			
895	0	1	0	1			
970	1	0	1	0			
1060	0	1	0	0			
1145	1	1	0	1			
1170	0	1	1	0			
1350	1	1	0	0			
1510	1	1	1	0			

3/4 HP Motor

CFM	Switch Number				Nominal Capacity		
	1	2	3	4	3.5	4.0	5.0
880	0	0	0	1			
975	0	0	0	0			
1080	0	0	1	0			
1125	1	0	0	1			
1265	1	0	0	0			
1390	0	1	0	1			
1455	1	0	1	0			
1590	0	1	0	0			
1690	1	1	0	1			
1785	0	1	1	0			
1915	1	1	0	0			
2125	1	1	1	0			

Table 1. Air Flow Selection for Variable Speed Models

Selecting the Minimum Electric Heat Airflow—

The minimum electric heat airflow is selected by setting switches 5 and 6. Selecting the minimum electric heat airflow sets the minimum air flow that will be produced whenever electric heater kits are used. When the electric heater kits are energized along with a heat pump, the airflow may be higher depending on the basic cooling/heat-pump airflow setting.

Reference Table 2 for recommended minimum electric heat airflow settings. The minimum electric heat airflow setting may be set higher, but must never be set lower than the setting shown in Table 2.

Selecting the Delay Profile—

The delay profile is selected by setting switches 7 and 8 (see Table 3). Delay profile selection controls the start-up and shut-down characteristics of the packaged heat pump unit. By varying the start-up and shut-down characteristics of the packaged heat pump unit the system can be optimized for energy efficiency, humidity control, and comfort.

Select “Delay A” or “Delay B” for highest energy efficiency. “Delay A” has a two-step “on” delay. The blower will begin operation at 31% airflow for 30 seconds. The second step operation is 75% airflow for 30 seconds. After the two-step “on” delay has been completed, the blower operation will be 100% until the thermostat has been satisfied. “Delay A” also provides a 60 second “off” delay at 50% airflow.

“Delay B” has a single step 30 second “on” delay at 50% airflow. “Delay B” also provides a 90 second “off” delay at 50% airflow. Select the delay profile which is most suited to the application.

The “De-Hum.” delay profile may be used when humidity control is desired without the use of the optional humidistat. If the “De-Hum.” delay profile is selected, the air handler will run at 75% airflow for the first 10 minutes of each cooling cycle. If the “De-Hum.” delay profile is selected, the basic cooling/heat-pump speed should be selected at or near the top of the range for that nominal capacity (see Table 1).

Nominal KW	CFM	Switch Number							
		1	2	3	4	5	6	7	8
0-5	500					0	0		
6-10	700					1	0		
11-15	900					0	1		
16-20	1100					1	1		

Note: 0=Off, 1=On

Table 2. Minimum Electric Heat Airflow (all models)

Delay Description	Switch Number							
	1	2	3	4	5	6	7	8
Delay A							0	0
Delay B							0	1
No Delay							1	0
De-Hum.							1	1

Note: 0=Off, 1=On

Table 3. Delay Settings (all models)

OPTIONAL HUMIDISTAT

The optional humidistat may be installed in the return air duct to provide excellent humidity control when needed and maximum system capacity and energy efficiency when humidity levels are normal. The humidistat senses when humidity in the return air stream is above a preset level (field adjustable) and sends a signal to the motor to reduce the airflow so that more moisture may be removed until the humidity level drops. The packaged heat pump unit is pre-programmed for humidistat operation. Remove jumper connector installed between the two terminals marked "HUM" on the circuit board.

Installation— Install the humidistat in the return air duct as directed in the installation instructions included with the kit. Wire the humidistat through the low-voltage wire entrance in the packaged heat pump unit to the quick-connect terminals marked "HUM". Wire the humidistat to open on rise in humidity.

OPTIONAL BONNET CONTROL SWITCH

The optional bonnet control switch and relay is recommended in variable speed heat-pump systems where supply air temperatures may drop below a comfortable level during normal operation. The bonnet control switch senses when the supply air temperature is below a preset comfort level (set by installer) and sends a signal to the motor to reduce the airflow. The supply air temperature increases when the airflow is reduced. Airflow will resume to normal levels if electric strip heat is energized. The air handler is pre-programmed to accept bonnet switch inputs. Remove jumper connector installed between "B1" and "B2" on the circuit board. The bonnet switch will not affect the cooling cycle.

Installation— Install the bonnet control switch in the supply air duct as directed in the installation instructions included with kit. Locate the bulb close to the unit, but not within the sight of the heating elements. Wire the bonnet control switch to the circuit board and through the low-voltage wire entrance in the packaged heat pump unit, and remove jumper connector between "B1" and "B2" wire switch to close on temperature rise. Set the thermostat as desired near 105°F.



CAUTION:

To avoid personal injury or property damage, make certain that the motor leads cannot come into contact with any uninsulated metal components of the unit.

Check all factory wiring per the unit wiring diagram and inspect the factory wiring connections to be sure none loosened during shipping or installation.

Low Voltage Connections

Room Thermostat — Several options are available for a room thermostat depending on the accessories installed with the unit. Select a thermostat which operates in conjunction with the installed accessories. The thermostat should be mounted about five feet above the ground on an inside wall. The thermostat should be kept away from drafts, slamming doors, lamps, direct sunlight, or in line with the supply air flow.

To install the thermostat:

1. Position the sub base on an inside wall and mark the mounting holes and thermostat cable openings.
2. Cut out the cable opening and route the thermostat cable from the unit's low voltage compartment to the thermostat location. The thermostat cable is supplied by the installer.
3. Connect the cable leads to the sub base or thermostat terminals and to the unit's low voltage pigtails as shown in **Figure 8**. A system wiring diagram is also provided on the inside of the control panel cover.
4. Secure sub base or thermostat to the wall using screws provided with the thermostat.
5. If sub base is used, install the correct thermostat housing to sub base.
6. Refer to thermostat instruction sheet for complete detailed mounting information.

Defrost Cycle Timer — The defrost cycle timer controls the time interval of the hot gas defrost after the defrost sensor closes. It is located in the lower left corner of the defrost control board on the low voltage side of the control box. Three interval settings are available: 30 minutes, 60 minutes, and 90 minutes. Time setting selection is dependent on the climate where the unit is being installed.

Example 1. Dry climate of Southern Arizona. A 90 minute setting is recommended.

Example 2. Moist climate of Seattle, Washington. A 30 minute setting is recommended.

To set the cycle timer, place the timing pin on the defrost control board to the desired time interval post.

Note: All units are shipped from the factory with the default time setting of 30 minutes.

Field Installed Electric Heat — These Single Package Heat Pumps are designed to allow optional electric heat to be field installed as required by the building's particular heating load. The options available for each unit are shown in the heater kit installation instructions. As noted in the instructions, a field installed circuit breaker kit is available as a means of electrical disconnect for the unit.

Install the heater kits as directed by the installation instructions that come as part of the heater kit. Follow all cautions and warnings as directed.

START UP AND SYSTEM CHECK

Pre-Start Check List

- Verify that the unit is level to allow proper condensate drainage.
- Verify that there is free airflow to and from the outdoor coil and that all clearance requirements are met.
- Verify that the duct work is sealed to prevent air leakage.
- Verify that the line voltage power leads are securely connected and the unit is properly grounded.
- Verify that the low voltage wires are securely connected to the correct leads on the low voltage terminal strip.
- Verify that all exterior panels are replaced and securely fastened.
- Verify that the outdoor fan turns freely.
- Verify that the power supply branch circuit overcurrent protection is sized properly.

- Verify that the thermostat is wired correctly. The thermostat function switch should be set to "Off" and the thermostat fan switch should be set to "Auto."

Start-Up Procedure

Close all electrical disconnects to energize the system.



WARNING:

If the unit is equipped with a crankcase heater, allow 24 hours prior to continuing the start up procedures to allow for heating of the refrigerant compressor crankcase. Failure to comply may result in damage and could cause premature failure of the system. This warning should be followed at initial start up and any time the power has been removed for 12 hours or longer.

Air Circulation — Leave the thermostat system switch set to "Off" and set the thermostat fan switch to "On." The blower motor should run continuously. Check for air delivery at the register(s). Ensure that there are no obstructions at the registers or in the duct work. Set thermostat fan switch to "Auto."

Short Cycle Protection — With the system operating in cooling mode, note the temperature setting of the thermostat and gradually raise the set-point temperature until the unit de-energizes. Immediately lower the set point temperature of the thermostat to its original setting and verify that the indoor blower is energized. Verify that after approximately 5 minutes the compressor and fan energize and that the temperature of the discharge air is cooler than the room temperature. This is available only for the single phase models.

System Cooling

1. Set the thermostat system switch to "Cool" and the thermostat fan switch to "Auto". Gradually lower the thermostat temperature switch below room temperature and observe that the blower, compressor, and fan energize. Check that air cooler than room temperature is being discharged at the register. Listen for any unusual noises.

2. After allowing the unit to run for several minutes, set the temperature selector above room temperature.
 - The fan and compressor cycles off with the thermostat.
 - The blower should also stop unless fan switch is set to "ON" position.

System Heating— If the unit has been equipped with optional electric heater kits, set the system thermostat switch to HEAT and set the thermostat fan switch to AUTO. Verify that the compressor and outdoor fan are not energized but that the blower and heaters are. Check for warm air at the supply registers.

DEFROST CONTROL BOARD OPERATION AND TESTING

1. Terminals "R"."C" must have 24±V present between them in order for the time delay and defrost sequences to be operational.
2. Jumper the "T2"."DFT" test pins. This will indicate to the board that the defrost T-stat is closed (if the compressor is running). Defrost T-stat is closed at 32° or below and is open at 68° or above. But it's state is unknown if the temperature is between 32°F and 68°F. The defrost thermostat tells the board whether a defrost cycle needs to be started or terminated. With the DFT closed the unit will run for 30/60/90 minutes in heat mode and then defrost the outdoor coil. The defrost will turn off the outdoor fan, turn on the compressor and raise the coil temperature to 68°F. This will open the DFT and terminate the defrost. If the DFT does not open the defrost will end after 10 minutes.
3. Defrost board speed-up. With compressor running in heat mode, next jump the "Test" pin to "C" on terminal strip. This will initiate a defrost test in 5, 10 or 15 seconds (This is determined by the 30, 60 or 90 minute defrost pin settings. The factory setting will be 30 minutes). Note that this will bypass the compressor off delay when the unit goes into defrost test and if left in defrost test, the delay will be bypassed when the test is terminated by the processor. If the jumper is removed before the test is over the processor will perform the remainder of a normal defrost. See step 2 above.
4. Remove the jumpers.

Note: The delay/no-delay pin concerns compressor operation during defrosts. The default setting is delay. Reciprocating compressors

should only use this setting in conjunction with an approved hard start kit. Scroll compressors that have noise issues while going into or coming out of defrost should use this 30 second delay to reduce the defrost noise. To switch from no-delay to delay remove the pin from the "no-delay" pin location and shift it to the "delay" pin location.

Speed up changes:

Manually initiating a defrost will cause the compressor to run continually when entering defrost.

Normal defrost operation:

To test normal defrost operation when the temperature is above 35°F, jumper "R" to "DFT" on the 624656 board and allow the unit to run for 30 minutes. Defrost will continue until the "R" to "DFT" jumper is removed or for 10 minutes. Remove the jumper.

The 5 minute time delay feature can be shortened 1 time to 1 second by jumping the "Test" to "C" terminal. Remove the jumper and repeat as desired.

Note: If jumper is left on the "Test" to "common" pins permanently, the defrost cycle will become inoperable.

Defrost Test Procedure for 624656

1. Jumper "T2" to "DFT" at the test terminals.
2. With unit running in heat mode, short the "TEST" terminal to the common terminal near it. This will speed up the board and cause it to enter defrost mode in 5/10/15 seconds depending on the defrost time selection. Compressor delay will not function during speed-up.
3. This test will end in 5 seconds if the "TEST"-common short is not removed.
4. Remove both the short and the "T2" to "DFT" jumper to terminate the defrost cycle. The 30 second compressor delay should operate normally.
5. Test is complete, reset thermostat to home owner preference.

Heating — For heat pumps or air conditioners provided with heating equipment, lower the thermostat temperature to the lowest obtainable setting and set the thermostat function switch to HEATING. The indoor blower and outdoor unit should stop running. Increase the set-point temperature of the thermostat to the maximum setting. Verify that the heating equipment has been energized (i.e., fossil fuel burner operating, etc.) and that the indoor blower energizes after a short period of time. Feel the air being

circulated by the indoor blower and verify that it is warmer than ambient temperature. Listen for any unusual noises. If present, locate and determine the source of the noise and correct as necessary.

NOTE: Other sources for heating (i.e.: electric furnace, fossil fuel furnace, air handler with electric heat options, etc.) that interface with the heat pump should be functionally checked to verify system operation and compatibility with the heat pump. Refer to the installation instructions for this equipment and perform a functional checkout in accordance with the manufacturer's instructions.

UNIT MAINTENANCE

 **WARNING:**

To avoid risk of electrical shock, personal injury, or death, disconnect all electrical power to the unit before performing any maintenance or service. The unit may have more than one electrical supply.

Refrigerant Charging — Packaged heat pumps are fully charged at the factory. The system refrigerant charge can be checked and adjusted through the service ports provided behind the front panel. Use only gauge lines which have a “Schrader” depression device present to actuate the valve. Draw a vacuum on gauge lines to remove air before attaching them to the service ports on the unit. Refrigerant charging must be done by qualified personnel familiar with safe and environmentally responsible refrigerant handling procedures.

 **WARNING:**

Single Packaged Heat Pumps are shipped fully charged and ready for installation. When a system is installed according to these instructions, no refrigerant charging is required. If repairs make it necessary for evacuation and charging, it should only be done by qualified, trained personnel thoroughly familiar with this equipment. Some local codes require licensed installation/service personnel to service this type of equipment. Under no circumstances should the owner attempt to install and/

or service this equipment. Failure to comply with this warning could result in property damage, personal injury, or death.

 **CAUTION:**

Use care when removing parts from this unit. Personal injury can result from sharp metal edges present in all equipment of sheet metal construction.

Routine Maintenance — Proper maintenance is important to achieve optimum performance from the heat pump. The ability to properly perform maintenance on this equipment requires certain mechanical skills and tools. If you do not possess these skills, contact your dealer for maintenance. Consult your local dealer about the availability of maintenance contracts. At a minimum, routine maintenance should include the following:

1. Inspect and clean or replace air filters at the beginning of each heating and cooling season, or more frequently if required.
2. Inspect the condensate drain and outdoor coil at the beginning of each cooling season. Remove any debris. Clean the outdoor coil and louvers as necessary using a mild detergent and water. Rinse thoroughly with water.
3. Inspect the electrical connections for tightness at the beginning of each heating and cooling season. Service as necessary.

 **CAUTION:**

The unit should never be operated without a filter in the return air system. Replace disposable filters with the same type and size.

4. The motors for the circulating air blower and the outdoor fan are pre-lubricated at the factory. No further oiling is required for the life of this product.

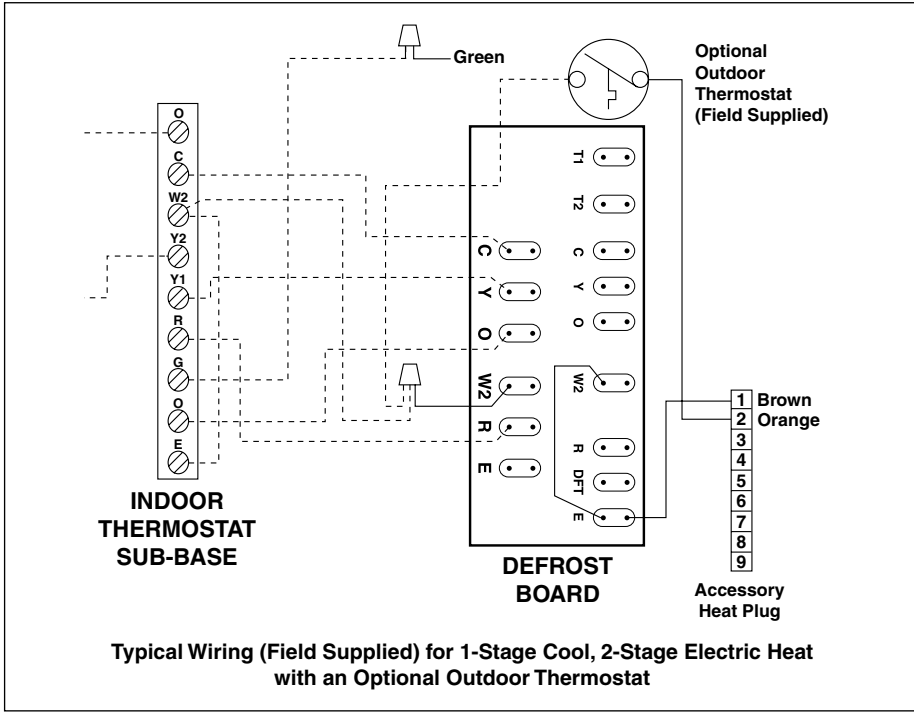
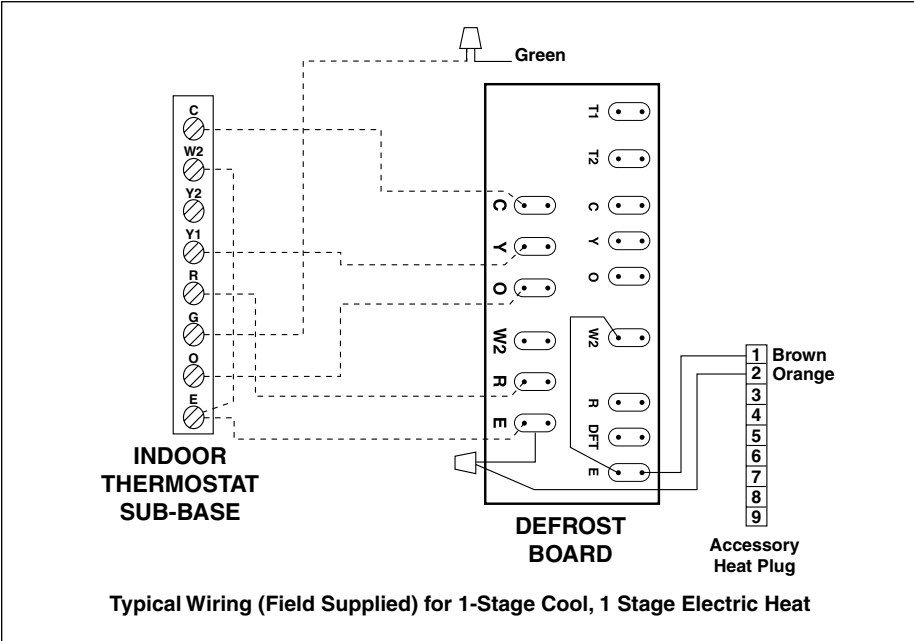

Figure 8. Typical Heat Pump Thermostat Connections

EXPANDED COOLING PERFORMANCE - 13 SEER H.P.

-X24K

O.D.T			85 °F			95 °F			105 °F			115 °F		
CFM	E.D.B.	E.W.B.	T.C.	S.C.	K.W.	T.C.	S.C.	K.W.	T.C.	S.C.	K.W.	T.C.	S.C.	K.W.
700	80	62	22.1	20.9	1.78	21.3	20.5	1.96	20.5	20.0	2.16	19.6	19.3	2.41
	80	67	24.0	17.4	1.79	23.2	17.0	1.97	22.2	16.6	2.18	21.2	16.2	2.42
	80	72	26.0	14.0	1.81	25.0	13.7	1.99	24.0	13.3	2.19	23.0	12.9	2.44
	75	63	22.4	17.0	1.77	21.5	16.6	1.96	20.7	16.2	2.17	19.7	15.7	2.41
850	80	62	23.0	22.9	1.78	22.3	22.3	1.96	21.5	21.5	2.17	20.7	20.7	2.42
	80	67	24.8	19.1	1.80	23.8	18.7	1.98	22.9	18.3	2.18	21.8	17.9	2.43
	80	72	26.7	15.1	1.81	25.7	14.8	2.00	24.7	14.4	2.20	23.6	14.0	2.44
	75	63	23.1	18.6	1.78	22.2	18.2	1.96	21.3	17.8	2.17	20.3	17.3	2.42
1000	80	62	24.0	24.0	1.80	23.2	23.2	1.97	22.4	22.4	2.18	21.5	21.5	2.43
	80	67	25.3	20.8	1.80	24.3	20.4	1.98	23.4	20.0	2.19	22.3	19.5	2.43
	80	72	27.2	16.2	1.82	26.2	15.8	2.00	25.1	15.4	2.21	24.0	15.0	2.45
	75	63	23.6	20.1	1.79	22.7	19.7	1.97	21.8	19.3	2.17	20.7	18.8	2.42

-X30K

O.D.T			85 °F			95 °F			105 °F			115 °F		
CFM	E.D.B.	E.W.B.	T.C.	S.C.	K.W.	T.C.	S.C.	K.W.	T.C.	S.C.	K.W.	T.C.	S.C.	K.W.
950	80	62	27.7	27.2	2.42	26.6	26.3	2.67	25.5	25.1	2.95	24.4	23.9	3.25
	80	67	30.1	23.2	2.43	28.9	22.6	2.68	27.6	22.0	2.97	26.3	21.4	3.27
	80	72	32.7	19.1	2.43	31.2	18.4	2.69	29.8	17.8	2.98	28.4	17.2	3.28
	75	63	28.0	22.4	2.42	26.8	21.8	2.67	25.7	21.2	2.95	24.5	20.6	3.26
1100	80	62	28.6	29.1	2.42	27.4	27.7	2.68	26.3	26.6	2.96	25.3	25.3	3.26
	80	67	30.9	24.9	2.43	29.5	24.2	2.69	28.2	23.6	2.97	26.9	23.0	3.27
	80	72	33.4	20.1	2.43	31.9	19.4	2.70	30.4	18.8	2.98	29.0	18.2	3.28
	75	63	28.7	23.9	2.42	27.5	23.3	2.68	26.3	22.6	2.96	25.0	21.8	3.26
1250	80	62	29.3	30.2	2.42	28.2	28.8	2.68	27.2	27.2	2.96	26.1	26.1	3.27
	80	67	31.5	26.5	2.43	30.1	25.5	2.69	28.7	24.9	2.97	27.3	24.2	3.27
	80	72	34.0	21.1	2.43	32.4	20.4	2.70	30.9	19.7	2.99	29.4	19.1	3.29
	75	63	29.3	25.1	2.43	28.0	24.4	2.68	26.7	23.8	2.96	25.5	23.1	3.26

-X36K

O.D.T			85 °F			95 °F			105 °F			115 °F		
CFM	E.D.B.	E.W.B.	T.C.	S.C.	K.W.	T.C.	S.C.	K.W.	T.C.	S.C.	K.W.	T.C.	S.C.	K.W.
1000	80	62	32.2	29.2	2.82	31.0	28.3	3.12	29.8	26.9	3.47	28.4	25.7	3.86
	80	67	35.0	25.1	2.84	33.7	24.5	3.14	32.3	23.8	3.50	30.9	23.1	3.88
	80	72	38.1	20.9	2.87	36.5	20.3	3.17	35.0	19.6	3.52	33.4	19.0	3.91
	75	63	32.7	24.2	2.83	31.4	23.6	3.13	30.1	22.9	3.47	28.7	22.2	3.87
1150	80	62	33.2	30.9	2.83	31.9	29.7	3.13	30.6	28.7	3.47	29.2	27.7	3.87
	80	67	36.0	26.7	2.85	34.6	26.0	3.15	33.1	25.3	3.50	31.6	24.6	3.89
	80	72	38.9	21.9	2.88	37.4	21.3	3.18	35.8	20.6	3.52	34.2	19.9	3.93
	75	63	33.6	25.7	2.84	32.3	25.0	3.13	30.9	24.3	3.47	29.5	23.6	3.88
1300	80	62	34.0	32.3	2.84	32.7	31.3	3.14	31.3	30.1	3.47	29.9	29.1	3.88
	80	67	36.7	28.1	2.86	35.3	27.5	3.16	33.8	26.8	3.50	32.2	26.0	3.91
	80	72	39.7	22.8	2.88	38.1	22.1	3.18	36.5	21.5	3.53	34.8	20.7	3.93
	75	63	34.3	27.1	2.84	32.9	26.4	3.14	31.5	25.7	3.49	30.0	24.9	3.88

EXPANDED COOLING PERFORMANCE - 13 SEER H.P. (Cont.)

-X42K

O.D.T			85 °F			95 °F			105 °F			115 °F		
CFM	E.D.B.	E.W.B.	T.C.	S.C.	K.W.	T.C.	S.C.	K.W.	T.C.	S.C.	K.W.	T.C.	S.C.	K.W.
1150	80	62	39.1	35.3	3.24	37.6	34.7	3.58	36.1	34.3	3.96	34.4	33.3	4.39
	80	67	42.4	29.4	3.28	40.7	28.7	3.62	39.0	28.0	4.01	37.2	27.2	4.44
	80	72	46.0	23.7	3.33	43.9	23.0	3.67	42.1	22.3	4.06	40.1	21.5	4.49
	75	63	39.5	28.6	3.25	38.0	27.9	3.59	36.3	27.2	3.97	34.6	26.4	4.39
1300	80	62	40.1	37.8	3.25	38.6	37.4	3.59	37.0	36.6	3.98	35.5	35.5	4.41
	80	67	43.3	31.3	3.29	41.6	30.6	3.64	39.8	29.8	4.02	37.9	29.0	4.45
	80	72	46.6	24.8	3.34	44.8	24.1	3.68	42.8	23.4	4.07	40.8	22.7	4.50
	75	63	40.4	30.4	3.26	38.8	29.7	3.60	37.1	28.9	3.98	35.3	28.1	4.41
1450	80	62	41.1	40.1	3.27	39.6	39.2	3.61	38.1	38.1	3.99	36.5	36.5	4.42
	80	67	44.0	33.1	3.30	42.2	32.3	3.64	40.4	31.6	4.03	38.5	30.8	4.46
	80	72	47.3	25.9	3.34	45.4	25.2	3.69	43.4	24.5	4.08	41.4	23.8	4.51
	75	63	41.1	32.1	3.27	39.4	31.3	3.61	37.7	30.6	3.99	35.9	29.8	4.42

-X48K

O.D.T			85 °F			95 °F			105 °F			115 °F		
CFM	E.D.B.	E.W.B.	T.C.	S.C.	K.W.	T.C.	S.C.	K.W.	T.C.	S.C.	K.W.	T.C.	S.C.	K.W.
1250	80	62	43.4	38.2	3.70	41.7	37.6	4.11	39.8	37.1	4.58	37.9	35.9	5.12
	80	67	47.0	32.1	3.76	45.1	31.3	4.17	43.1	30.5	4.65	41.0	29.6	5.19
	80	72	51.1	25.9	3.83	48.9	25.1	4.24	46.5	24.3	4.71	44.2	23.5	5.27
	75	63	43.9	31.3	3.71	42.1	30.5	4.12	40.2	29.6	4.58	38.2	28.7	5.13
1400	80	62	44.4	40.6	3.72	42.6	40.1	4.13	40.7	39.3	4.60	38.8	38.3	5.14
	80	67	48.0	34.0	3.78	46.0	33.1	4.19	43.9	32.3	4.66	41.7	31.2	5.21
	80	72	51.6	27.0	3.84	49.5	26.2	4.25	47.2	25.4	4.73	44.9	24.5	5.29
	75	63	44.8	33.1	3.73	43.0	32.2	4.14	41.0	31.2	4.61	38.9	30.2	5.15
1550	80	62	45.3	43.0	3.73	43.5	42.2	4.14	41.6	41.5	4.61	39.7	39.7	5.17
	80	67	48.8	35.5	3.79	46.7	34.7	4.20	44.6	33.8	4.68	42.4	32.9	5.23
	80	72	52.4	28.1	3.85	50.2	27.3	4.26	47.9	26.5	4.75	45.5	25.6	5.30
	75	63	45.6	34.5	3.74	43.7	33.7	4.15	41.6	32.8	4.62	39.5	31.8	5.17

-X60K

O.D.T			85 °F			95 °F			105 °F			115 °F		
CFM	E.D.B.	E.W.B.	T.C.	S.C.	K.W.	T.C.	S.C.	K.W.	T.C.	S.C.	K.W.	T.C.	S.C.	K.W.
1500	80	62	51.4	45.6	4.53	49.4	44.4	4.97	47.3	43.1	5.48	45.1	41.5	6.06
	80	67	56.2	38.9	4.61	54.0	37.9	5.05	51.7	37.0	5.56	49.3	35.9	6.13
	80	72	61.1	31.9	4.69	58.6	31.0	5.14	56.2	30.0	5.64	53.6	29.0	6.21
	75	63	52.2	38.0	4.55	50.3	37.0	4.99	48.1	36.0	5.49	45.9	35.0	6.07
1650	80	62	52.4	47.8	4.55	50.4	46.5	4.99	48.2	45.3	5.49	46.0	44.0	6.07
	80	67	57.2	40.7	4.63	55.0	39.8	5.07	52.6	38.8	5.57	50.1	37.7	6.14
	80	72	62.0	33.1	4.71	59.6	32.1	5.15	57.1	31.2	5.66	54.4	30.2	6.23
	75	63	53.3	39.7	4.56	51.2	38.7	5.01	49.0	37.7	5.51	46.6	36.7	6.09
1800	80	62	53.4	49.8	4.56	51.3	48.6	5.00	49.1	47.1	5.51	46.8	45.7	6.09
	80	67	58.1	42.5	4.64	55.8	41.5	5.08	53.4	40.5	5.59	50.8	39.5	6.15
	80	72	62.9	34.2	4.73	60.4	33.3	5.17	57.9	32.3	5.67	55.2	31.3	6.24
	75	63	54.1	41.4	4.58	52.0	40.4	5.02	49.7	39.4	5.53	47.3	38.3	6.09

EXPANDED HEATING PERFORMANCE - 13 SEER H.P.

Q4SD-X60K

Indoor T.		OUTDOOR TEMPERATURE (Deg. F)																																																
		10				17				20				30				40				47				50				60																				
		CFM	Deg.F	MBH	COP	kW	MBH	COP	kW	MBH	COP	kW	MBH	COP	kW	MBH	COP	kW	MBH	COP	kW	MBH	COP	kW	MBH	COP	kW	MBH	COP	kW																				
1500	60	25.2	1.92	3.83	30.6	2.29	3.91	32.9	2.45	3.94	40.6	2.94	4.06	48.4	3.41	4.17	53.8	3.72	4.24	56.1	3.85	4.28	63.9	4.27	4.39	70	24.3	1.72	4.14	29.6	2.06	4.21	31.9	2.21	4.24	39.5	2.67	4.34	47.0	3.10	4.45	52.4	3.40	4.52	54.6	3.52	4.55	62.2	3.92	4.65
	80	23.8	1.56	4.46	28.9	1.87	4.53	31.2	2.00	4.56	38.5	2.42	4.66	45.9	2.83	4.76	51.0	3.10	4.83	53.2	3.21	4.86	60.6	3.58	4.96	60	25.4	1.93	3.86	30.9	2.31	3.93	33.3	2.46	3.96	41.1	2.97	4.06	49.0	3.45	4.16	54.5	3.77	4.24	56.9	3.91	4.27	64.7	4.35	4.37
	1700	70	24.6	1.74	4.15	30.0	2.08	4.22	32.3	2.23	4.25	40.0	2.70	4.34	47.6	3.15	4.43	53.0	3.45	4.50	55.3	3.58	4.53	63.0	4.00	4.62	80	24.0	1.57	4.49	29.3	1.89	4.55	31.5	2.02	4.57	39.0	2.45	4.66	46.5	2.87	4.74	51.7	3.16	4.80	53.9	3.28	4.83	61.4	3.67
1900	60	25.5	1.92	3.89	31.1	2.30	3.96	33.5	2.46	3.99	41.5	2.98	4.09	49.5	3.47	4.18	55.1	3.80	4.25	57.5	3.94	4.28	65.5	4.38	4.38	70	25.0	1.75	4.19	30.4	2.10	4.25	32.7	2.24	4.28	40.4	2.72	4.36	48.2	3.18	4.44	53.6	3.49	4.50	55.9	3.62	4.53	63.7	4.05	4.61
	80	24.3	1.58	4.52	29.6	1.90	4.57	31.9	2.03	4.59	39.4	2.48	4.67	46.9	2.90	4.74	52.2	3.20	4.79	54.5	3.32	4.81	62.0	3.72	4.89	60	25.4	1.93	3.86	30.9	2.31	3.93	33.3	2.46	3.96	41.1	2.97	4.06	49.0	3.45	4.16	54.5	3.77	4.24	56.9	3.91	4.27	64.7	4.35	4.37
	1700	70	24.6	1.74	4.15	30.0	2.08	4.22	32.3	2.23	4.25	40.0	2.70	4.34	47.6	3.15	4.43	53.0	3.45	4.50	55.3	3.58	4.53	63.0	4.00	4.62	80	24.0	1.57	4.49	29.3	1.89	4.55	31.5	2.02	4.57	39.0	2.45	4.66	46.5	2.87	4.74	51.7	3.16	4.80	53.9	3.28	4.83	61.4	3.67

Q4SD-X60K

Indoor T.		OUTDOOR TEMPERATURE (Deg. F)																																																
		10				17				20				30				40				47				50				60																				
		CFM	Deg.F	MBH	COP	kW	MBH	COP	kW	MBH	COP	kW	MBH	COP	kW	MBH	COP	kW	MBH	COP	kW	MBH	COP	kW	MBH	COP	kW	MBH	COP	kW																				
1500	60	25.2	1.92	3.83	30.6	2.29	3.91	32.9	2.45	3.94	40.6	2.94	4.06	48.4	3.41	4.17	53.8	3.72	4.24	56.1	3.85	4.28	63.9	4.27	4.39	70	24.3	1.72	4.14	29.6	2.06	4.21	31.9	2.21	4.24	39.5	2.67	4.34	47.0	3.10	4.45	52.4	3.40	4.52	54.6	3.52	4.55	62.2	3.92	4.65
	80	23.8	1.56	4.46	28.9	1.87	4.53	31.2	2.00	4.56	38.5	2.42	4.66	45.9	2.83	4.76	51.0	3.10	4.83	53.2	3.21	4.86	60.6	3.58	4.96	60	25.4	1.93	3.86	30.9	2.31	3.93	33.3	2.46	3.96	41.1	2.97	4.06	49.0	3.45	4.16	54.5	3.77	4.24	56.9	3.91	4.27	64.7	4.35	4.37
	1700	70	24.6	1.74	4.15	30.0	2.08	4.22	32.3	2.23	4.25	40.0	2.70	4.34	47.6	3.15	4.43	53.0	3.45	4.50	55.3	3.58	4.53	63.0	4.00	4.62	80	24.0	1.57	4.49	29.3	1.89	4.55	31.5	2.02	4.57	39.0	2.45	4.66	46.5	2.87	4.74	51.7	3.16	4.80	53.9	3.28	4.83	61.4	3.67
1900	60	25.5	1.92	3.89	31.1	2.30	3.96	33.5	2.46	3.99	41.5	2.98	4.09	49.5	3.47	4.18	55.1	3.80	4.25	57.5	3.94	4.28	65.5	4.38	4.38	70	25.0	1.75	4.19	30.4	2.10	4.25	32.7	2.24	4.28	40.4	2.72	4.36	48.2	3.18	4.44	53.6	3.49	4.50	55.9	3.62	4.53	63.7	4.05	4.61
	80	24.3	1.58	4.52	29.6	1.90	4.57	31.9	2.03	4.59	39.4	2.48	4.67	46.9	2.90	4.74	52.2	3.20	4.79	54.5	3.32	4.81	62.0	3.72	4.89	60	25.4	1.93	3.86	30.9	2.31	3.93	33.3	2.46	3.96	41.1	2.97	4.06	49.0	3.45	4.16	54.5	3.77	4.24	56.9	3.91	4.27	64.7	4.35	4.37
	1700	70	24.6	1.74	4.15	30.0	2.08	4.22	32.3	2.23	4.25	40.0	2.70	4.34	47.6	3.15	4.43	53.0	3.45	4.50	55.3	3.58	4.53	63.0	4.00	4.62	80	24.0	1.57	4.49	29.3	1.89	4.55	31.5	2.02	4.57	39.0	2.45	4.66	46.5	2.87	4.74	51.7	3.16	4.80	53.9	3.28	4.83	61.4	3.67

EXPANDED HEATING PERFORMANCE - 13 SEER H.P. (Cont.)

Q4SD-X60K

Indoor T. Deg.F		OUTDOOR TEMPERATURE (Deg. F)																							
		10		17		20		30		40		47		50		60									
		MBH	COP	kw	MBH	COP	kw	MBH	COP	kw	MBH	COP	kw	MBH	COP	kw	MBH	COP	kw						
1500	60	25.2	1.92	3.83	30.6	2.29	3.91	32.9	2.45	3.94	40.6	2.94	4.06	48.4	3.41	4.17	53.8	3.72	4.24	56.1	3.85	4.28	63.9	4.27	4.39
	70	24.3	1.72	4.14	29.6	2.06	4.21	31.9	2.21	4.24	39.5	2.67	4.34	47.0	3.10	4.45	52.4	3.40	4.52	54.6	3.52	4.55	62.2	3.92	4.65
	80	23.8	1.56	4.46	28.9	1.87	4.53	31.2	2.00	4.56	38.5	2.42	4.66	45.9	2.83	4.76	51.0	3.10	4.83	53.2	3.21	4.86	60.6	3.58	4.96
1700	60	25.4	1.93	3.86	30.9	2.31	3.93	33.3	2.46	3.96	41.1	2.97	4.06	49.0	3.45	4.16	54.5	3.77	4.24	56.9	3.91	4.27	64.7	4.35	4.37
	70	24.6	1.74	4.15	30.0	2.08	4.22	32.3	2.23	4.25	40.0	2.70	4.34	47.6	3.15	4.43	53.0	3.45	4.50	55.3	3.58	4.53	63.0	4.00	4.62
	80	24.0	1.57	4.49	29.3	1.89	4.55	31.5	2.02	4.57	39.0	2.45	4.66	46.5	2.87	4.74	51.7	3.16	4.80	53.9	3.28	4.83	61.4	3.67	4.91
1900	60	25.5	1.92	3.89	31.1	2.30	3.96	33.5	2.46	3.99	41.5	2.98	4.09	49.5	3.47	4.18	55.1	3.80	4.25	57.5	3.94	4.28	65.5	4.38	4.38
	70	25.0	1.75	4.19	30.4	2.10	4.25	32.7	2.24	4.28	40.4	2.72	4.36	48.2	3.18	4.44	53.6	3.49	4.50	55.9	3.62	4.53	63.7	4.05	4.61
	80	24.3	1.58	4.52	29.6	1.90	4.57	31.9	2.03	4.59	39.4	2.48	4.67	46.9	2.90	4.74	52.2	3.20	4.79	54.5	3.32	4.81	62.0	3.72	4.89

Q4SD-X60K

Indoor T. Deg.F		OUTDOOR TEMPERATURE (Deg. F)																							
		10		17		20		30		40		47		50		60									
		MBH	COP	kw	MBH	COP	kw	MBH	COP	kw	MBH	COP	kw	MBH	COP	kw	MBH	COP	kw						
1500	60	25.2	1.92	3.83	30.6	2.29	3.91	32.9	2.45	3.94	40.6	2.94	4.06	48.4	3.41	4.17	53.8	3.72	4.24	56.1	3.85	4.28	63.9	4.27	4.39
	70	24.3	1.72	4.14	29.6	2.06	4.21	31.9	2.21	4.24	39.5	2.67	4.34	47.0	3.10	4.45	52.4	3.40	4.52	54.6	3.52	4.55	62.2	3.92	4.65
	80	23.8	1.56	4.46	28.9	1.87	4.53	31.2	2.00	4.56	38.5	2.42	4.66	45.9	2.83	4.76	51.0	3.10	4.83	53.2	3.21	4.86	60.6	3.58	4.96
1700	60	25.4	1.93	3.86	30.9	2.31	3.93	33.3	2.46	3.96	41.1	2.97	4.06	49.0	3.45	4.16	54.5	3.77	4.24	56.9	3.91	4.27	64.7	4.35	4.37
	70	24.6	1.74	4.15	30.0	2.08	4.22	32.3	2.23	4.25	40.0	2.70	4.34	47.6	3.15	4.43	53.0	3.45	4.50	55.3	3.58	4.53	63.0	4.00	4.62
	80	24.0	1.57	4.49	29.3	1.89	4.55	31.5	2.02	4.57	39.0	2.45	4.66	46.5	2.87	4.74	51.7	3.16	4.80	53.9	3.28	4.83	61.4	3.67	4.91
1900	60	25.5	1.92	3.89	31.1	2.30	3.96	33.5	2.46	3.99	41.5	2.98	4.09	49.5	3.47	4.18	55.1	3.80	4.25	57.5	3.94	4.28	65.5	4.38	4.38
	70	25.0	1.75	4.19	30.4	2.10	4.25	32.7	2.24	4.28	40.4	2.72	4.36	48.2	3.18	4.44	53.6	3.49	4.50	55.9	3.62	4.53	63.7	4.05	4.61
	80	24.3	1.58	4.52	29.6	1.90	4.57	31.9	2.03	4.59	39.4	2.48	4.67	46.9	2.90	4.74	52.2	3.20	4.79	54.5	3.32	4.81	62.0	3.72	4.89

EXPANDED HEATING PERFORMANCE - 13 SEER H.P. (Cont.)

Q4SD-X60K

Indoor T. Deg.F		OUTDOOR TEMPERATURE (Deg. F)																							
		10		17		20		30		40		47		50		60									
		MBH	COP	MBH	COP	MBH	COP	MBH	COP	MBH	COP	MBH	COP	MBH	COP	MBH	COP								
1500	60	25.2	1.92	3.83	30.6	2.29	3.91	32.9	2.45	3.94	40.6	2.94	4.06	48.4	3.41	4.17	53.8	3.72	4.24	56.1	3.85	4.28	63.9	4.27	4.39
	70	24.3	1.72	4.14	29.6	2.06	4.21	31.9	2.21	4.24	39.5	2.67	4.34	47.0	3.10	4.45	52.4	3.40	4.52	54.6	3.52	4.55	62.2	3.92	4.65
	80	23.8	1.56	4.46	28.9	1.87	4.53	31.2	2.00	4.56	38.5	2.42	4.66	45.9	2.83	4.76	51.0	3.10	4.83	53.2	3.21	4.86	60.6	3.58	4.96
1700	60	25.4	1.93	3.86	30.9	2.31	3.93	33.3	2.46	3.96	41.1	2.97	4.06	49.0	3.45	4.16	54.5	3.77	4.24	56.9	3.91	4.27	64.7	4.35	4.37
	70	24.6	1.74	4.15	30.0	2.08	4.22	32.3	2.23	4.25	40.0	2.70	4.34	47.6	3.15	4.43	53.0	3.45	4.50	55.3	3.58	4.53	63.0	4.00	4.62
	80	24.0	1.57	4.49	29.3	1.89	4.55	31.5	2.02	4.57	39.0	2.45	4.66	46.5	2.87	4.74	51.7	3.16	4.80	53.9	3.28	4.83	61.4	3.67	4.91
1900	60	25.5	1.92	3.89	31.1	2.30	3.96	33.5	2.46	3.99	41.5	2.98	4.09	49.5	3.47	4.18	55.1	3.80	4.25	57.5	3.94	4.28	65.5	4.38	4.38
	70	25.0	1.75	4.19	30.4	2.10	4.25	32.7	2.24	4.28	40.4	2.72	4.36	48.2	3.18	4.44	53.6	3.49	4.50	55.9	3.62	4.53	63.7	4.05	4.61
	80	24.3	1.58	4.52	29.6	1.90	4.57	31.9	2.03	4.59	39.4	2.48	4.67	46.9	2.90	4.74	52.2	3.20	4.79	54.5	3.32	4.81	62.0	3.72	4.89

Q4SD-X60K

Indoor T. Deg.F		OUTDOOR TEMPERATURE (Deg. F)																							
		10		17		20		30		40		47		50		60									
		MBH	COP	MBH	COP	MBH	COP	MBH	COP	MBH	COP	MBH	COP	MBH	COP	MBH	COP								
1500	60	25.2	1.92	3.83	30.6	2.29	3.91	32.9	2.45	3.94	40.6	2.94	4.06	48.4	3.41	4.17	53.8	3.72	4.24	56.1	3.85	4.28	63.9	4.27	4.39
	70	24.3	1.72	4.14	29.6	2.06	4.21	31.9	2.21	4.24	39.5	2.67	4.34	47.0	3.10	4.45	52.4	3.40	4.52	54.6	3.52	4.55	62.2	3.92	4.65
	80	23.8	1.56	4.46	28.9	1.87	4.53	31.2	2.00	4.56	38.5	2.42	4.66	45.9	2.83	4.76	51.0	3.10	4.83	53.2	3.21	4.86	60.6	3.58	4.96
1700	60	25.4	1.93	3.86	30.9	2.31	3.93	33.3	2.46	3.96	41.1	2.97	4.06	49.0	3.45	4.16	54.5	3.77	4.24	56.9	3.91	4.27	64.7	4.35	4.37
	70	24.6	1.74	4.15	30.0	2.08	4.22	32.3	2.23	4.25	40.0	2.70	4.34	47.6	3.15	4.43	53.0	3.45	4.50	55.3	3.58	4.53	63.0	4.00	4.62
	80	24.0	1.57	4.49	29.3	1.89	4.55	31.5	2.02	4.57	39.0	2.45	4.66	46.5	2.87	4.74	51.7	3.16	4.80	53.9	3.28	4.83	61.4	3.67	4.91
1900	60	25.5	1.92	3.89	31.1	2.30	3.96	33.5	2.46	3.99	41.5	2.98	4.09	49.5	3.47	4.18	55.1	3.80	4.25	57.5	3.94	4.28	65.5	4.38	4.38
	70	25.0	1.75	4.19	30.4	2.10	4.25	32.7	2.24	4.28	40.4	2.72	4.36	48.2	3.18	4.44	53.6	3.49	4.50	55.9	3.62	4.53	63.7	4.05	4.61
	80	24.3	1.58	4.52	29.6	1.90	4.57	31.9	2.03	4.59	39.4	2.48	4.67	46.9	2.90	4.74	52.2	3.20	4.79	54.5	3.32	4.81	62.0	3.72	4.89



**INSTALLER: PLEASE LEAVE THESE
INSTALLATION INSTRUCTIONS WITH
THE HOMEOWNER**

Specifications & illustrations subject to change
without notice or incurring obligations (08/15).
O'Fallon, MO, © Nortek Global HVAC LLC 2015.
All Rights Reserved.



708439A (Replaces 7084390)