

INSTALLATION INSTRUCTIONS

For Revision 2 models produced after August 1, 2021



Upflow / Horizontal Furnace

This product complies with SJVAPCD 4905 and SCAQMD 1111 with NOx levels below 14 ng/J when operated on natural gas.

⚠ WARNING

FIRE OR EXPLOSION HAZARD

- Failure to follow safety warnings exactly could result in serious injury, death or property damage.
- Installation and service must be performed by a qualified installer, service agency or the gas supplier.
- Do not store or use gasoline or other flammable vapors and liquids in the vicinity of this or any other appliance.

WHAT TO DO IF YOU SMELL GAS

- Do not try to light any appliance.
- Do not touch any electrical switch; do not use any phone in your building.
- Leave the building immediately.
- Immediately call your gas supplier from a neighbors phone. Follow the gas suppliers instructions.
- If you cannot reach your gas supplier, call the fire department.

DO NOT DESTROY. PLEASE READ CAREFULLY & KEEP IN A SAFE PLACE FOR FUTURE REFERENCE.

TABLE OF CONTENTS

IMPORTANT SAFETY INFORMATION.....	3	START-UP & ADJUSTMENTS.....	15
REQUIREMENTS & CODES	3	Pre-Start Check List	15
Combustion Air Quality	4	Start-up Procedures	15
Clearances to Combustible Materials	4	Verifying & Adjusting Input Rate.....	16
Heating Load	4	Verifying & Adjusting Temperature Rise.....	16
Installation in a Garage.....	4	Verifying Burner Operation	16
Operation of Furnace During Construction.....	5	Verify Operation of the Supply Air Limit Switch	16
COMBUSTION AIR & VENTING REQUIREMENTS	5	OPERATING SEQUENCE	17
Installation In A Confined Space	6	Heating Cycle	17
Air From Inside	6	Cooling Cycle	17
Outdoor Air from a Crawl Space or Vented Attic	6	Fan Mode	17
Outdoor Air Using Vertical Ducts	6	MAINTENANCE	17
Outdoor Air Using Horizontal Ducts.....	6	TROUBLESHOOTING	18
Air Directly Through An Exterior Wall	7	FURNACE COMPONENTS	19
Alternate Method of Providing Air from Outside:	7	FIGURES & TABLES.....	20
Installation In An Unconfined Space.....	7	Figure 18. Furnace Dimensions.....	20
Category I Venting.....	8	Airflow Data	21
Flexible Vent Systems	8	Table 3. Blower Data for *SA-055U-T23A* Models ..	21
CIRCULATING AIR REQUIREMENTS.....	9	Table 4. Blower Data for *SA-070U-T24B* Models ..	22
Plenums & Air Ducts.....	9	Table 5. Blower Data for *SA-100U-T35C* Models ..	23
Return Air Connections	9	Electrical Information	24
Upflow & Horizontal Furnaces	9	Figure 19. Wiring Diagram.....	24
Supply Air Connections	9	Figure 20. Ladder Diagram.....	25
Acoustical Treatments	10	Gas Information	26
FURNACE INSTALLATION.....	10	Table 6. Gas Flow Rates	26
About The Furnace	10	Table 7. Gas Pipe Capacities	26
Before You Install the Furnace	10	Table 8. Natural Gas Heating Values	27
Locating the Furnace.....	10	Table 9. High Altitude Deration Chart for Natural Gas - High Heating Value	27
Upflow Furnaces.....	10	Table 10. High Altitude Deration Chart for Natural Gas - Low Heating Value.....	27
Horizontal Furnaces	11	INSTALLATION CHECKLIST.....	28
Pressure Switch Tubing.....	11	REPLACEMENT PARTS	28
Bottom Panel Removal.....	11		
GAS SUPPLY & PIPING.....	12		
Alternate Bottom Panel Removal.....	12		
Leak Check.....	13		
High Altitude Application.....	13		
ELECTRICAL WIRING	14		
Line Voltage Wiring	14		
Grounding.....	14		
Thermostat / Low Voltage Connections.....	14		
Heat Anticipator	15		

IMPORTANT SAFETY INFORMATION

INSTALLER: Please read all instructions before servicing this equipment. Pay attention to all safety warnings and any other special notes highlighted in the manual. Safety markings are used frequently throughout this manual to designate a degree or level of seriousness and should not be ignored. **WARNING** - indicates a potentially hazardous situation that if not avoided, could result in personal injury or death. **CAUTION** - indicates a potentially hazardous situation that if not avoided, may result in minor or moderate injury or property damage.

WARNING:

The safety information listed in this manual must be followed during the installation, service, and operation of this unit. Unqualified individuals should not attempt to interpret these instructions or install this equipment. Failure to follow safety recommendations could result in possible damage to the equipment, serious personal injury or death.

WARNING:

Improper installation, service, adjustment, or maintenance may cause explosion, fire, electrical shock or other hazardous conditions which may result in personal injury or property damage. Unless otherwise noted in these instructions, only factory authorized kits or accessories may be used with this product.

WARNING:

Unless otherwise noted in these instructions, only factory authorized kits or accessories may be used with or when modifying this product.

WARNING:

Do not install this furnace if any part has been submerged under water. A flood damaged furnace is extremely dangerous. Attempts to use the furnace may result in fire or explosion. A qualified service agency should be contacted to inspect the furnace and to replace any electrical or control system parts that have been wet or under water.

- To minimize equipment failure or personal injury, it is essential that only qualified individuals install, service, or maintain this equipment. If you do not possess mechanical skills or tools, call your local dealer for assistance.
- Follow all precautions in the literature, on tags, and on labels provided with the equipment. Read and thoroughly understand the instructions provided with the equipment prior to performing the installation and operational checkout of the equipment.

- Use caution when handling this appliance or removing components. Personal injury can occur from sharp metal edges present in all sheet metal constructed equipment.
- Do not store any of the following on, or in contact with, the unit: Rags, brooms, vacuum cleaners, or other cleaning tools, spray or aerosol cans, soap powders, bleaches, waxes, cleaning compounds, plastics or plastic containers, paper bags or other paper products, gasoline, kerosene, cigarette lighter fluid, dry cleaning fluids, paint thinners, or other volatile fluids.
- The installer should become familiar with the units wiring diagram before making any electrical connections to the unit. See [Figure 18, \(page 20\)](#) or the unit wiring label.
- Always reinstall the doors on the furnace after servicing. Do not operate the furnace without all doors and covers in place.

REQUIREMENTS & CODES

- This furnace must be installed in accordance with these instructions, all applicable local building codes and the current revision of the National Fuel Gas Code (NFPA54/ANSI Z223.1).
- Use only with type of gas approved for this furnace. Refer to the furnace rating plate.
- Install this furnace only in a location and position as specified on [page 5](#).
- Provide adequate combustion and ventilation air to the furnace space as specified on [page 5](#).
- Combustion products must be discharged outdoors. Connect this furnace to an approved vent system only, as specified on [page 8](#).
- Never test for gas leaks with an open flame. Use a commercially available soap solution to check all connections. See [page 13](#).
- This furnace is designed to operate with a maximum external static pressure of 0.5 inches of water column. Consult [Table 3, \(page 21\)](#), [Table 4, \(page 22\)](#), [Table 5, \(page 23\)](#), and the rating plate for the proper circulating air flow and temperature rise. It is important that the duct system be designed to handle the desired flow rate and temperature rise. An improperly designed duct system can result in nuisance shutdowns, and comfort or noise issues.
- When supply ducts carry air circulated by the furnace to areas outside the space containing the furnace, the return air shall also be handled by duct(s) sealed to the furnace casing and terminating outside the space containing the furnace. See [page 9](#).
- A gas-fired furnace for installation in a residential garage must be installed as specified on [page 4](#).
- This furnace is not approved for installation in mobile homes. Installing this furnace in a mobile home could cause fire, property damage, and/or personal injury.

The information listed in the section below is for reference purposes only and does not necessarily have jurisdiction over local or state codes. Always consult with local authorities before installing any gas appliance.

Combustion & Ventilation Air

- US: National Fuel Gas Code (NFPA), Air for Combustion and Ventilation

Duct Systems

- US and CANADA: Air Conditioning Contractors Association (ACCA) Manual D, Sheet Metal and Air Conditioning Contractors National Association (SMACNA), or American

Society of Heating, Refrigeration, and Air Conditioning Engineers (ASHRAE) Fundamentals Handbook

Electrical Connections

- US: National Electrical Code (NEC) ANSI/NFPA 70

Gas Piping & Gas Pipe Pressure Testing

- US: NFGC and National Plumbing Codes

General Installation

- US: Current edition of the NFGC and the NFPA 90B. For copies, contact the National Fire Protection Association Inc., Batterymarch Park, Quincy, MA 02269; or American Gas Association, 400 N. Capitol, N.W., Washington DC 20001 or www.NFPA.org

Safety

- US: (NFGC) NFPA 54–1999/ANSI Z223.1 and the Installation Standards, Warm Air Heating and Air Conditioning Systems ANSI/NFPA 90B.

Combustion Air Quality

CAUTION:

Combustion air must not be drawn from a corrosive atmosphere.

To maximize heat exchanger life, the combustion air must be free of chemicals that can form corrosive acidic compounds in the combustion gases. The recommended source of combustion air is to use outdoor air. However, the use of indoor air in most applications is acceptable except as listed:

- If the furnace is installed in a confined space, it is required that the necessary combustion air come from the outdoors by way of attic, crawl space, air duct, or direct opening. For installations in confined spaces, see [page 5](#) for combustion air requirements.
- Installations in these locations may require outdoor air for combustion, due to chemical exposures:
 - Commercial buildings
 - Buildings with indoor pools
 - Furnaces installed in laundry rooms
 - Furnaces installed in hobby or craft rooms
 - Furnaces installed near chemical storage areas
- Exposure to the following substances in the combustion air supply may require outdoor air for combustion:
 - Permanent wave solutions
 - Chlorinated waxes and cleaners
 - Chlorine based swimming pool chemicals
 - Water softening chemicals
 - De-icing salts or chemicals
 - Carbon Tetrachloride
 - Halogen type refrigerants
 - Cleaning solvents (perchloroethylene)
 - Printing inks, paint removers, varnishes, etc.
 - Hydrochloric Acid
 - Cements and glues
 - Antistatic fabric softeners
 - Masonry acid washing materials

Clearances to Combustible Materials

This furnace is Design Certified in the U.S. and Canada by CSA International for the minimum clearances to combustible materials. **NOTE:** The furnace is listed for installation on combustible or non-combustible flooring. However, wood is the only combustible flooring allowed for installation. To obtain model number and specific clearance information, refer to the furnace rating plate, located inside of the furnace cabinet.

Access for positioning and servicing the unit must be considered when locating unit. The need to provide clearance for access to panels or doors may require clearance distances over and above the requirements. **Allow 24 inches minimum clearance from the front of the unit. However 36 inches is strongly recommended.** See [Figure 1, \(page 5\)](#) for minimum clearance requirements.

Heating Load

The furnace should be sized to provide the design heating load requirement. Heating load estimates can be made using approved methods available from Air Conditioning Contractors of America (Manual J); American Society of Heating, Refrigerating, and Air Conditioning Engineers; or other approved engineering methods. **Excessive oversizing of the furnace could cause the furnace and/or vent to fail prematurely.**

The ductwork should be appropriately sized to the capacity of the furnace to ensure its proper airflow rating. For installations above 2,000 ft., the furnace should have a sea level input rating large enough that it will meet the heating load after deration for altitude.

Installation in a Garage

WARNING:

Do not place combustible materials on or against the furnace cabinet or within 6 inches of the vent pipe. Do not place combustible materials, including gasoline or any other flammable vapors and liquids, in the vicinity of the furnace.

This gas-fired furnace may be installed in a residential garage with the provision that the burners and igniter are located no less than 18 inches (457mm) above the floor. The furnace must be located or protected to prevent physical damage by vehicles.

COMBUSTION AIR & VENTING REQUIREMENTS

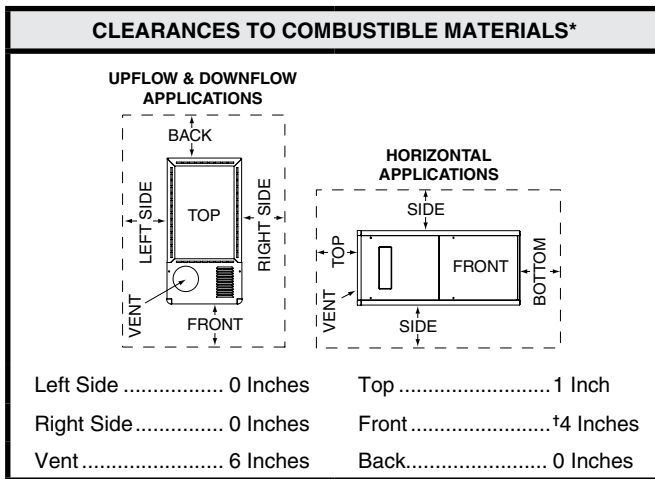

†Allow 24 in. minimum clearance for servicing. Recommended clearance is 36 in.

Figure 1. Minimum Clearances to Combustible Materials

Operation of Furnace During Construction

CAUTION:

Operating gas furnaces in construction environments can cause a variety of problems within the furnace and may significantly reduce the life or the performance of the furnace. Therefore operating the furnace during construction is not permitted and will void the warranty.

WARNING:

CARBON MONOXIDE POISONING HAZARD
Failure to follow the steps outlined below for each appliance connected to the venting system being placed into operation could result in carbon monoxide poisoning or death.

The following steps shall be followed with each individual appliance connected to the venting system being placed in operation, while all other appliances connected to the venting system are not in operation:

1. Seal any unused openings in the venting system.
2. Inspect the venting system for proper size and horizontal pitch, as required in the National Fuel Gas Code, ANSI Z223.1/NFPA 54 Natural Gas and Propane Installation Codes and these instructions. Determine that there is no blockage or restriction, leakage, corrosion and other deficiencies which could cause an unsafe condition.
3. As far as practical, close all building doors and windows and all doors between the space in which the appliance(s) connected to the venting system are located and other spaces of the building.
4. Close fireplace dampers.
5. Turn on clothes dryers and any appliance not connected to the venting system. Turn on any exhaust fans, such as range hoods and bathroom exhausts, so they are operating at maximum speed. Do not operate a summer exhaust fan.
6. Follow the lighting instructions. Place the appliance being inspected into operation. Adjust the thermostat so appliance is operating continuously.
7. Test for spillage from draft hood equipped appliances at the draft hood relief opening after 5 minutes of main burner operation. Use the flame of a match or candle.
8. If improper venting is observed during any of the above tests, the venting system must be corrected in accordance with the National Fuel Gas Code, ANSI Z223.1/NFPA 54 Natural Gas and Propane Installation Codes.
9. After it has been determined that each appliance connected to the venting system properly vents when tested as outlined above, return doors, windows, exhaust fans, fireplace dampers and any other gas-fired burning appliance to their previous conditions of use.

IMPORTANT INFORMATION:

- Provisions must be made during the installation of this furnace that provide an adequate supply of air for combustion. Furnace installation using methods other than those described in the following sections must comply with the National Fuel Gas Code (NFGC) and all applicable local codes.
- Instructions for determining the adequacy of combustion air for an installation can be found in the

current revision of the NFGC (ANSI Z223.1 / NFPA54). Consult local codes for special requirements. These requirements are for US installations as found in the NFGC.

CAUTION:

Exhaust fans, clothes dryers, fireplaces and other appliances that force air from the house to the outdoors can create a negative pressure inside the house, resulting in improper furnace operation or unsafe conditions. It is imperative that sufficient air exchange with the outdoors is provided to prevent depressurization. Additional information about how to test for negative pressure problems can be found in the NFGC.

Air openings on top and front of the furnace and openings in closet doors or walls must never be restricted. If the furnace is operated without adequate air for combustion, it may cause the blocked vent switch to activate and turn off the gas supply to the burners.

IMPORTANT NOTE

This safety device can be auto or manually reset. **DO NOT** install jumper wires across these switches to defeat their function or reset a switch without identifying and correcting the fault condition. If a switch must be replaced, use only the correct sized part specified in the Replacement Parts List.

Installation In A Confined Space

A confined space is an area with volume less than 50 cubic feet per 1,000 Btuh of the combined input rates of all appliances drawing combustion air from that space. Furnace closets, small equipment rooms and garages are confined spaces. Furnaces installed in a confined space which supply heated air to areas outside the space must draw return air from outside the space and must have the return air ducts tightly sealed to the furnace.

The required sizing of these openings is determined by whether inside or outside air is used to support combustion, the method by which the air is brought to the space, and by the total input rate of all appliances in the space. In all cases, the minimum dimension of any combustion air opening is 3 inches.

Air From Inside

If combustion air is taken from the heated space, the two openings must each have a free area of at least 1 in² per 1,000 Btuh of total input of all appliances in the confined space, but **not less than** 100 in² of free area. See [Figure 2](#) and the [Example](#) below.

EXAMPLE

If the combined input rate of all appliances is less than or equal to 100,000 Btuh, each opening must have a free area of at least 100 in². If the combined input rate of all appliances is 120,000 Btuh, each opening must have a free area of at least 120 in².

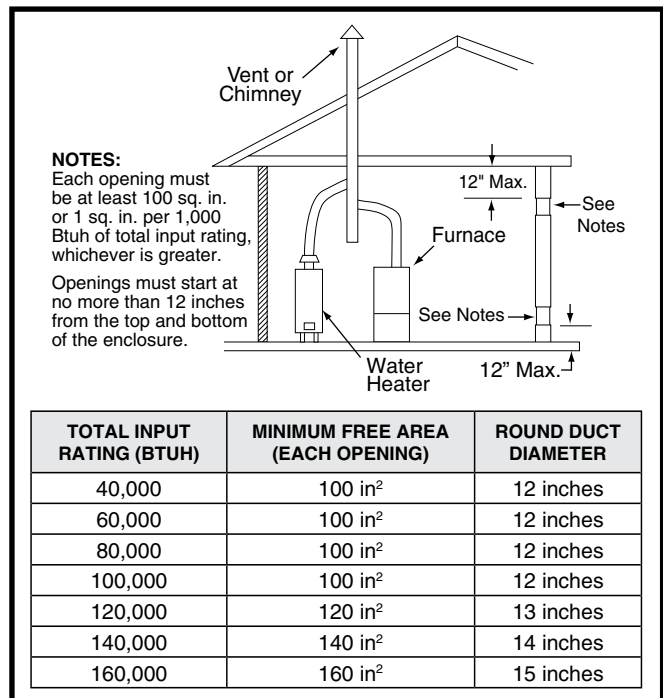

Figure 2. Combustion Air Drawn from Inside

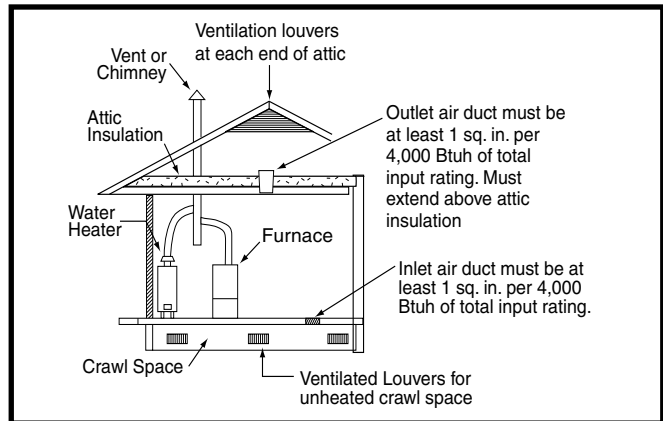

Figure 3. Combustion Air Drawn from a Crawl Space or Vented Attic

Outdoor Air from a Crawl Space or Vented Attic

When the openings can freely exchange air with the outdoors, each opening shall have a minimum free area of 1 in² per 4,000 Btuh of total appliance input. The openings shall exchange directly, or by ducts, with the outdoor spaces (crawl or attic) that freely exchange with the outdoors. See [Figure 3](#).

Outdoor Air Using Vertical Ducts

If combustion air is taken from outdoors through vertical ducts, the openings and ducts must have a minimum free area of 1 in² per 4,000 Btuh of total appliance input. In installations drawing combustion air from a ventilated attic, both air ducts must extend above the attic insulation. See [Figure 4](#), (page 7).

Outdoor Air Using Horizontal Ducts

If combustion air is taken from outdoors through horizontal ducts, the openings and ducts must have a minimum free area of 1 in² per 2,000 Btuh of total appliance input. See [Figure 5](#), (page 7).

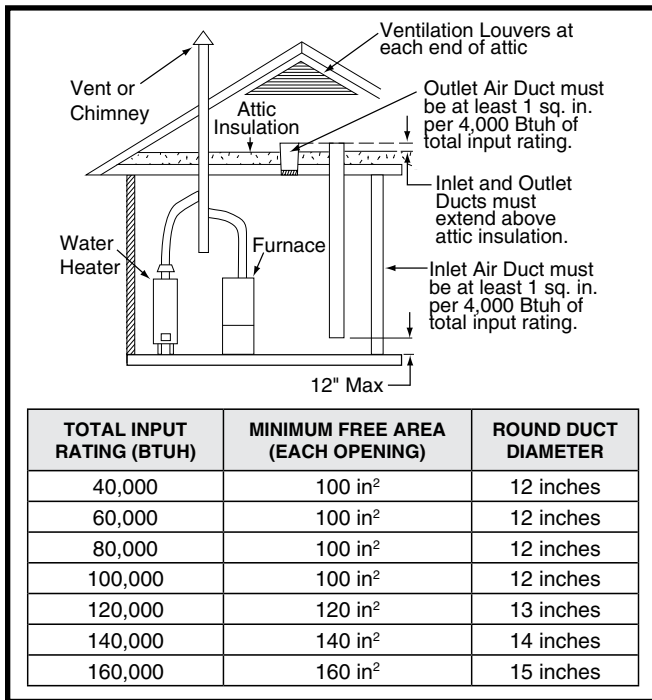

Figure 4. Combustion Air Drawn from Outside Through Vertical Ducts

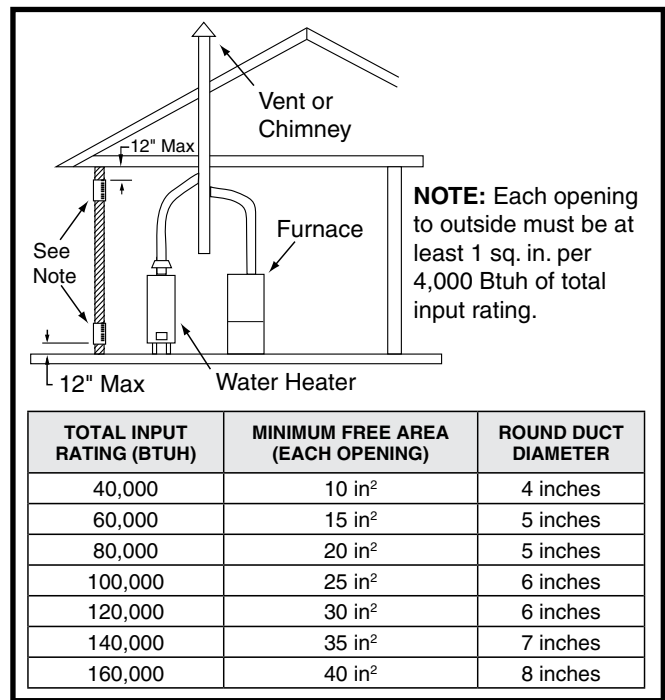

Figure 6. Combustion Air Drawn from Outside Through an Exterior Wall

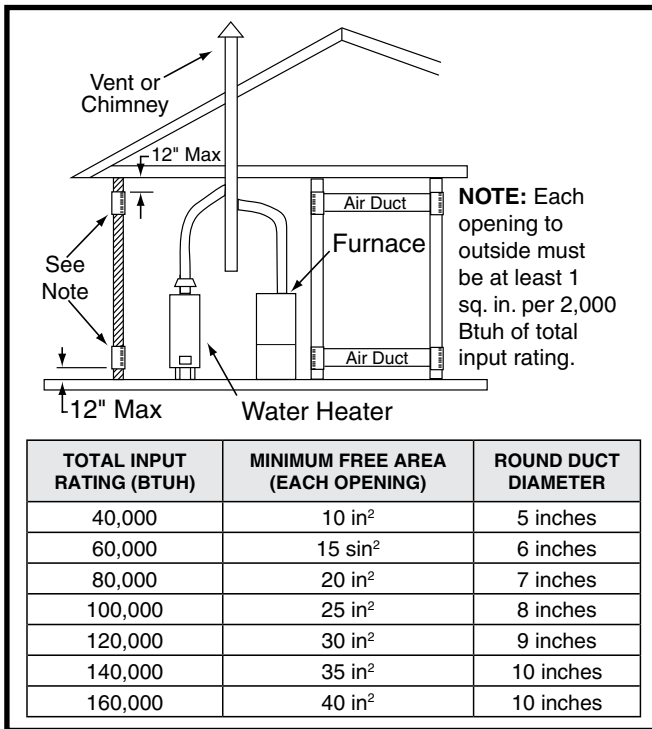

Figure 5. Combustion Air Drawn from Outside Through Horizontal Ducts

Air Directly Through An Exterior Wall

If combustion air is provided directly through an exterior wall, the two openings must each have free area of at least 1in² per 4,000 Btuh of total appliance input. See [Figure 6](#).

Alternate Method of Providing Air from Outside:

If acceptable under local Codes, it is permitted to provide outside air using one opening (See NFGC). Generally,

confined spaces must have 2 openings in the space for combustion air. One opening must be within 12 inches of the ceiling, and the other must be within 12 inches of the floor. However, an alternative method recently adopted by the NFGC uses one opening within 12 inches of the top of the space. This method may be used if it is acceptable to the local codes.

THE FOLLOWING CONDITIONS MUST BE MET:

1. The opening must start within 12" of the top of the structure and connect with the out of doors through vertical or horizontal ducts or be ducted to a crawl or attic space that connects with the out of doors.
2. The opening must have a minimum free area of 1 in². per 3,000 Btu per hour of the total input rating of all equipment located in the enclosure.
3. The free area must not be less than the sum of all the areas of the vent connectors in the enclosure.

Installation In An Unconfined Space

An unconfined space is an area including all rooms not separated by doors with a volume greater than 50 cubic feet per 1,000 Btuh of the combined input rates of all appliances which draw combustion air from that space.

In general, a furnace installed in an unconfined space will not require outside air for combustion. However, in homes built for energy efficiency (low air change rates), it may be necessary to provide outside air to ensure adequate combustion and venting, even though the furnace is located in an unconfined space. See [Example](#).

EXAMPLE

A space with a water heater rated at 45,000 Btuh input and a furnace rated at 75,000 Btuh requires a volume of 6,000 cubic feet [50 x (45 + 75) = 6,000] to be considered unconfined. If the space has an 8 foot ceiling, the floor area of the space must be 750 sq. ft. (6,000 / 8 = 750).

Category I Venting

This furnace is listed as a Category I vented appliance. Category I furnaces generally operate with a slight negative pressure (draft) and must be vented vertically or near vertical. Additionally it is important to guard against excessive condensation.

WARNING:

Upon completion of the furnace installation, carefully inspect the entire flue system both inside and outside the furnace to assure it is properly sealed. Leaks in the flue system can result in serious personal injury or death due to exposure of flue products, including carbon monoxide.

WARNING:

Venting into an unlined masonry chimney or concrete chimney is prohibited. This may result in improper draft and excess condensation forming in the chimney.

- **This furnace must be vented in compliance with the current revision of the National Fuel Gas Code (ANSI-Z223.1/NFPA54) and the instructions provided below. Refer to the NFGC for approved vent tables. Consult local codes for special requirements.**
- **Category I furnace installations must be connected to a factory built chimney or vent complying with a recognized standard, or a masonry or concrete chimney lined with a lining material acceptable to the authority having jurisdiction.**
- **In the U.S., this furnace must never be vented to a chimney or flue that services a fireplace or other appliance designed to burn solid fuel. If the furnace vent is to be connected to a chimney serving a fireplace, the fireplace must be sealed off from the chimney.**
- This furnace may be vented with a dedicated venting system or common vented with other Category I appliances. The vent system dimensions and material must conform to the NFGC or local Codes. Generally, this means using Type B vent pipe or a lined masonry chimney. When consulting the vent sizing tables in the NFGC, the MAX capacity of the vent must be greater than the furnaces high fire rate. The MIN capacity must be lower than the low fire rate. If the venting system is inappropriate for the furnace, the venting system will need to be modified to comply with NFGC or local codes. **The minimum diameter of any vent pipe is 4 inches.**

- The venting system should be designed to have the minimum number of elbows or turns. All horizontal runs shall slope upwards from the furnace at ¼ inch per running foot of vent. Supports for the vent pipe must be installed a minimum of every five feet along the vent run to ensure no displacement after installation. Under no circumstances shall any portion of the vent system extend into or pass through any return air duct, supply air duct, or plenum.
- Single wall vent connectors may be used under the limited capacity ranges found in the vent sizing tables. It is recommended that Type B double wall vent be used for the connector whenever possible. An existing masonry chimney should be inspected and relined if necessary.
- Single wall metal vertical vents shall not be used for Category I venting. The furnace vent, if metal, may be insulated if local codes allow. Any part of the vent system, metal vent only, not exposed to weather, but which are exposed to temperatures below 35° F (1° C) must be insulated to prevent condensation. All vent insulation shall be foil backed fiberglass of one inch minimum thickness.
- Sheet metal fasteners should be used to secure the vent pipe to the furnace flue. However, the NFGC states that alternative vent products may be attached according to the vent manufacturers instructions.
- When an existing furnace is removed from a vent system serving other appliances, the existing vent system may no longer be sized to properly vent the remaining appliances. An improperly sized venting system can result in the formation of condensate, leakage, or spillage. The existing vent system should also be checked to make sure it remains in compliance with NFGC. If it isn't, the vent system must be brought into compliance before installing the furnace.

Flexible Vent Systems

Flexible venting systems are approved for use providing they are listed for the application and meet all local Code requirements. These systems are primarily used to line existing masonry chimneys. They must be sized to the application according to the sizing tables in the National Fuel Gas Code, including the required 20% reduction in maximum capacity.

Flexible venting systems are permitted to be used as the vent connector. However, great care must be taken to ensure that there are no sags in the venting system which could accumulate condensate. The flexible vent system must be supported at no more than 5 foot intervals and maintain a minimum slope of ¼ inch per foot of horizontal run.

CIRCULATING AIR REQUIREMENTS

WARNING:

Do not allow combustion products to enter the circulating air supply. Failure to prevent the circulation of combustion products into the living space can create potentially hazardous conditions including carbon monoxide poisoning that could result in personal injury or death.

All return ductwork must be secured to the furnace with sheet metal screws. For installations in confined spaces, all return ductwork must be adequately sealed. When return air is provided through the bottom of the furnace, the joint between the furnace and the return air plenum must be air tight.

The surface that the furnace is mounted on must provide sound physical support of the furnace with no gaps, cracks or sagging between the furnace and the floor or platform.

Return air and circulating air ductwork must not be connected to any other heat producing device such as a fireplace insert, stove, etc. This may result in fire, explosion, carbon monoxide poisoning, personal injury, or property damage.

Plenums & Air Ducts

- Plenums and air ducts must be installed in accordance with the Standard for the Installation of Air Conditioning and Ventilating Systems (NFPA No. 90A) or the Standard for the Installation of Warm Air Heating and Air Conditioning Systems (NFPA No. 90B).
- [Table 3, \(page 21\)](#), [Table 4, \(page 22\)](#), & [Table 5, \(page 23\)](#) contains the maximum airflow and temperature rise data for each furnace input rate. If the maximum airflow is 1,600 CFM or more, it is recommended that two openings be used for return air on upflow furnaces.
- It is recommended that the outlet duct contain a removable access panel. The opening should be accessible when the furnace is installed in service and shall be of a size that smoke or reflected light may be observed inside the casing to indicate the presence of leaks in the heat exchanger. The cover for the opening shall be attached in such a manner as to prevent leaks.
- If outside air is used as return air to the furnace for ventilation or to improve indoor air quality, the system must be designed so that the return air is not less than 60° F (15° C) during operation. If a combination of indoor and outdoor air is used, the ducts and damper system must be designed so that the return air supply to the furnace is equal to the return air supply under normal, indoor return air applications.
- When a cooling system is installed which uses the furnace blower to provide airflow over the indoor coil, the coil must be installed downstream (on the outlet side) of the furnace or in parallel with the furnace.
- If a cooling system is installed in parallel with the furnace, a damper must be installed to prevent chilled air from entering the furnace and condensing on the heat exchanger. If a manually operated damper is installed, it must be designed so that operation of the furnace is prevented when the

damper is in the cooling position and operation of the cooling system is prevented when the damper is in the heating position.

- Seal all connections and joints with industrial grade sealing tape or liquid sealant. Requirements for sealing ductwork vary from region to region. Consult with local codes for requirements specific to your area.

Return Air Connections

- In applications where the supply ducts carry heated air to areas outside the space where the furnace is installed, the return air must be delivered to the furnace by duct(s) secured to the furnace casing, running full size and without interruption. **Do not use the back of the furnace for return air.**
- Position the furnace with the return air ductwork ensuring even alignment of furnace (or coil casing) air opening and return air duct. **NOTE:** The ductwork must have an opening equal to that of the return air opening of the furnace (or coil casing). See [Figure 16, \(page 18\)](#) for return air opening size.

Upflow & Horizontal Furnaces

- The return air ductwork may be connected to the left side, right side, or bottom of the furnace. **NOTE:** If using only the left or right side of the furnace for return air, the bottom panel ([Figure 16](#)) must not be removed from the bottom of the furnace, except for airflows 1,600 CFM or higher.
-

WARNING:

The bottom panel of the furnace must be in place when the furnace is installed with side return air ducts. Removal of all or part of the base could cause circulation of combustible products into the living space and create potentially hazardous conditions, including carbon monoxide poisoning that could result in personal injury or death.

- **Side Return Installations:** To attach the return air duct to the left or right side of the furnace, punch out the 4 knockouts from the side of the furnace ([Figure 16](#)). Using sharp metal cutters, cut an opening between all 4 knockouts to expose the blower assembly. Position the return air duct over the opening and secure to the side with sheet metal screws.
- **Bottom Return Installations:** If using the bottom of the furnace for return air, the bottom panel ([Figure 16](#)) must be removed from the bottom of the furnace. See [page 11](#) for removal instructions. Position the furnace over the return air duct and secure together with sheet metal screws. Make sure the screws penetrate the duct and furnace casing.

Supply Air Connections

- The supply air must be delivered to the heated space by duct(s) secured to the furnace or coil box casing, running full size and without interruption.
- To attach the supply air duct to upflow & horizontal furnaces, bend the flanges on the furnace upward 90° with wide duct pliers. See [Figure 16, \(page 18\)](#) for furnace flange locations. **NOTE:** If system installation includes AC coil

casing, bend the flanges on the coil casing upward 90° before attaching the supply air duct.

- Position the supply air ductwork onto the furnace ensuring even alignment of furnace air opening and supply air duct.
NOTE: The ductwork must have an opening equal to that of the supply air opening of the furnace. See [Figure 16](#) for supply air opening size.

Acoustical Treatments

Damping ducts, flexible vibration isolators, or pleated media-style filters on the return air inlet of the furnace may be used to reduce the transmission of equipment noise emanating from the furnace. These treatments can produce a quieter installation, particularly in the heated space. However, they can increase the pressure drop in the duct system. Care must be taken to maintain the proper maximum pressure rise across the furnace, temperature rise and flow rate. This may mean increasing the duct size and/or reducing the blower speed. These treatments must be constructed and installed in accordance with NFPA and SMACNA construction standards. Consult with local codes for special requirements. For best sound performance, be sure to install all the needed gaskets and grommets around penetrations into the furnace, such as for electrical wiring.

FURNACE INSTALLATION

These Installation procedures are suggested for typical furnace installations. Since each installation is different, the sequence of instructions may differ from the actual installation. **Only qualified HVAC technicians should install this furnace.**

The installer must be familiar with and comply with all codes and regulations applicable to the installation of these heating appliances and related equipment. In the absence of local codes, the installation must be in accordance with the current provisions of one or more of the following standards.

- American National Standard (ANSI-Z223.1/NFPA-54).
- American National Standard (ANSI-C1/NFPA-70).

About The Furnace

The Ultra-Low NOx series furnace is designed only for indoor dry installations and can be readily connected to the high static duct system of a home. Ultra-Low NOx series gas furnaces are shipped ready for installation in the upflow or horizontal right or left positions. Units are approved for single / multistory residential structures in freestanding /closet / alcove configurations.

This appliance will provide many years of safe and dependable comfort, providing it is properly installed and maintained. Abuse, improper use, and/or improper maintenance can shorten the life of the appliance and create unsafe hazards. Please read all instructions before installing the unit.

Approved installation, operation, and maintenance of this appliance must be in accordance with the listed specifications contained in these instructions and other documents supplied with the furnace and/or optional air conditioning equipment. Unless it is noted differently in this manual, only use factory authorized kits and accessories on this appliance. Refer to local authorities having jurisdiction for further information.

Before You Install the Furnace

- ✓ This equipment is securely packaged at the time of shipment and upon arrival should be carefully inspected for damage prior to installing the equipment at the job site. Claims for damage (apparent or concealed) should be filed immediately with the carrier.
- ✓ Check the electrical supply and verify the power supply is adequate for unit operation. The system must be wired and provided with circuit protection in accordance with local building codes. If there is any question concerning the power supply, contact the local power company.
- ✓ Verify the air delivery of the furnace is adequate to handle the static pressure drop of the coil, filter, and duct work.

Locating the Furnace

- The dimensions of the room or alcove must be able to accommodate the overall size of the furnace and required clearances to combustible materials listed in [Figure 1, \(page 5\)](#). Access for positioning and servicing must also be considered when locating the unit. To determine the required clearances needed for installation, refer to [Figure 16, \(page 18\)](#) for overall dimensions.
- The furnace must be installed on a solid surface and must be level front-to-back and side-to-side at installation. The surface that the furnace is mounted on must provide sound physical support of the unit. Secure the furnace to the floor.
- The furnace should be installed as close to the center of the air distribution system as possible and attached to a properly installed duct system. **Do not use the back of the furnace for return air.** See [page 9](#) for circulating requirements.
- The furnace must be installed so that all electrical components are protected from water.
- The plenum attached to the A/C coil box and ductwork within 3 ft. of the furnace must be installed so that surfaces are at least 1" from combustible construction.
- When installed in a residential garage, the furnace must be positioned so the burners and the source of the ignition are located no less than 18 inches above the floor and protected from physical damage by vehicles.
- The furnace must be installed upstream from a refrigeration system.
- The furnace requires special venting materials and installation procedures. See [page 8](#) & [page 9](#) for venting guidelines and specifications.

Upflow Furnaces

WARNING:

The furnace must not be installed directly on carpeting, tile, or any combustible material other than wood flooring. Failure to comply may result in fire, property damage or personal injury.

Ultra-Low NOx series gas furnaces are shipped with the bottom panel installed as shown in [Figure 16, \(page 18\)](#). If the furnace is installed with only side return air, the bottom panel must not be removed. If the furnace is installed with bottom return air, the bottom panel must be removed. See Bottom Panel Removal on [page 11](#).

Horizontal Furnaces

WARNING:

The furnace must not be installed directly on carpeting, tile, or any combustible material other than wood flooring.

- The Ultra-Low NOx series gas furnace can be installed horizontally (Figure 7) in an attic, basement, crawl space or alcove. They can also be suspended from a ceiling in a basement or utility room in either a right to left airflow or left to right airflow as shown in Figure 8.
- Ultra-Low NOx series furnaces are shipped with the bottom panel installed. If the furnace is installed horizontally, remove the bottom panel from the furnace before attaching the duct system. See Bottom Panel Removal on page 11.
- If installing the furnace with an evaporator coil (in an attic), it is required that a drip pan be placed under the furnace and the evaporator coil. If the installation is on a combustible platform (Figure 7), it is recommended that the drip pan extend at least 12 inches past the top and front of the furnace. **NOTE:** Although it is not required to use a drip pan for heat only applications, state and local codes may require it.
- If suspending the furnace from the ceiling, assemble a support frame (Figure 8) using slotted iron channel and full threaded rod. Fasten the frame together with nuts, washers, and lockwashers. Secure the support frame to the rafters with lag bolts. The furnace can also be suspended using steel straps around each end of the furnace. The straps should be attached to the furnace with sheet metal screws and to the rafters with bolts.
- It is recommended for further reduction of fire hazard that cement board or sheet metal be placed between the furnace and the combustible floor and extend 12 inches beyond the front of the door and top of the furnace.

Pressure Switch Tubing

Figure 11 displays the proper routing of pressure switch tubing for Ultra-Low NOx furnaces. The tubing connects at one end of the pressure switch and is routed directly onto the static tap of the inducer assembly.

Bottom Panel Removal

The steps listed below explain the proper method for removing the bottom panel from the furnace. See Figure 10, (page 12).

1. Remove the door from the blower compartment.
2. Disconnect the blower motor wiring harness from the control board.
3. Remove two screws securing the blower assembly to the furnace.
4. Carefully pull the blower assembly out thru the front of the furnace.
5. Remove all screws securing bottom panel to bottom of furnace and front brace.
6. Lift up and slide bottom panel out through front of furnace.
7. Reinstall the blower assembly in reverse order.

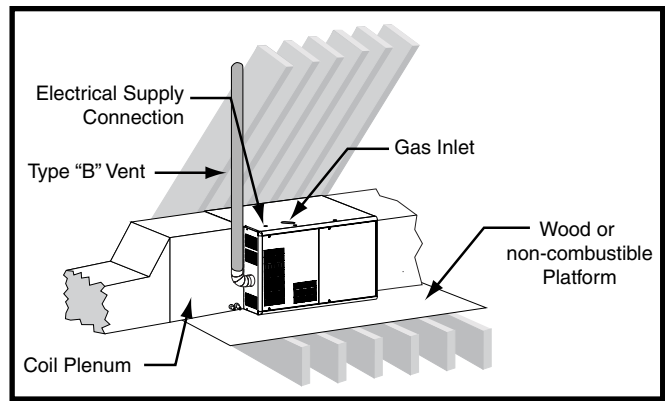

Figure 7. Horizontally Installed on a Platform

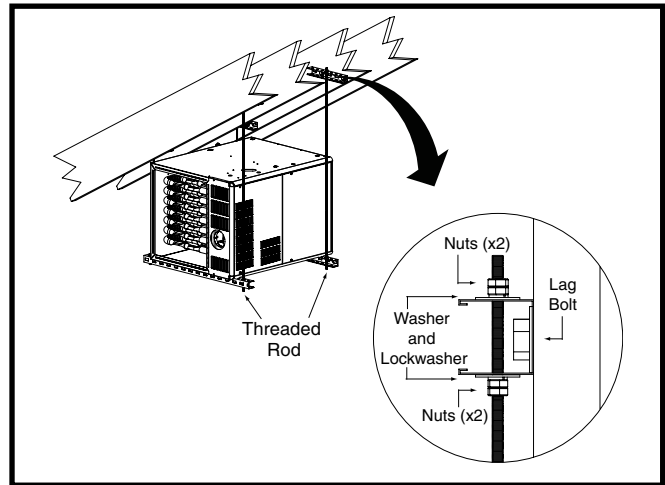

Figure 8. Horizontally Suspended in Attic

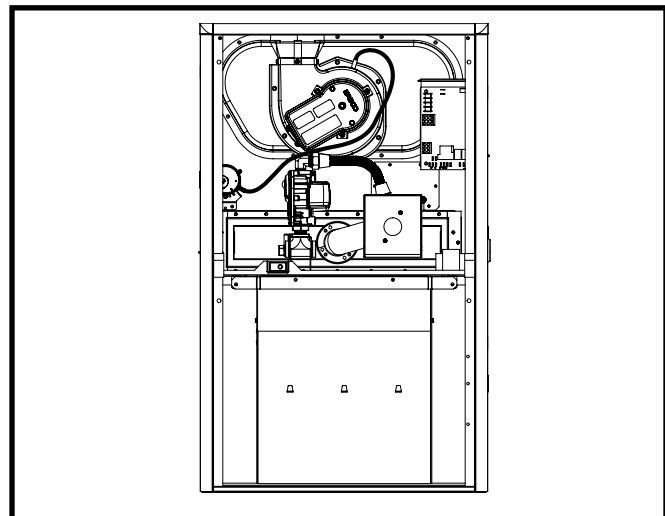

Figure 9. Pressure Switch Tubing

GAS SUPPLY & PIPING

WARNING:

FIRE OR EXPLOSION HAZARD

- Failure to follow safety warnings exactly could result in serious injury, death or property damage.
- Installation and service must be performed by a qualified installer, service agency or the gas supplier.
- Do not store or use gasoline or other flammable vapors and liquids in the vicinity of this or any other appliance.

WHAT TO DO IF YOU SMELL GAS

- Do not try to light any appliance.
- Do not touch any electrical switch; do not use any phone in your building.
- Leave the building immediately.
- Immediately call your gas supplier from a neighbor's phone. Follow the gas supplier's instructions.
- If you cannot reach your gas supplier, call the fire department.

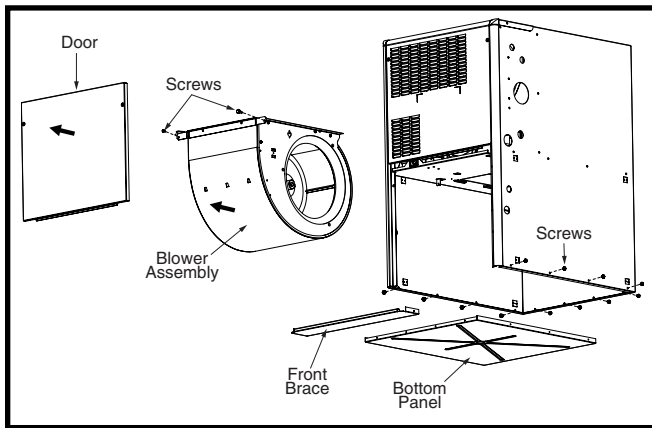

Figure 10. Bottom Panel Removal

Alternate Bottom Panel Removal

If the bottom panel cannot be removed using the previous instructions, the steps below are an alternate method for removing the bottom panel. See [Figure 11](#).

1. Remove the door from the blower compartment.
2. Remove all screws securing the bottom panel to the front brace.
3. Remove two screws securing the furnace cabinet to the blower deck.
4. Remove all screws securing the furnace cabinet to the bottom panel.
5. Remove the screw securing the bottom corner of the furnace cabinet to the front brace.
6. Carefully spread the bottom corner of the furnace cabinet outwards while sliding the bottom panel out through the front of the furnace.
7. Reassemble the furnace in reverse order.

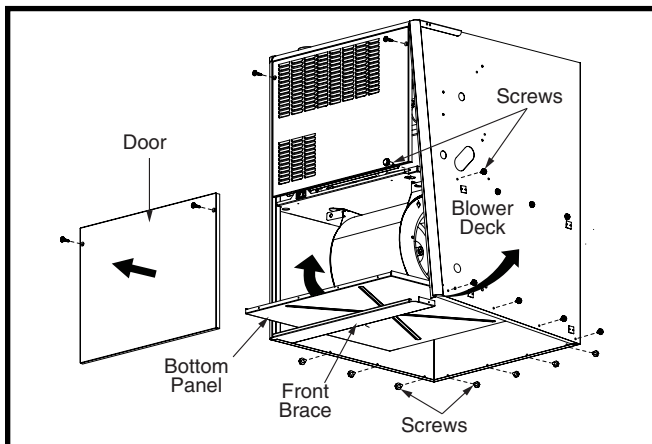
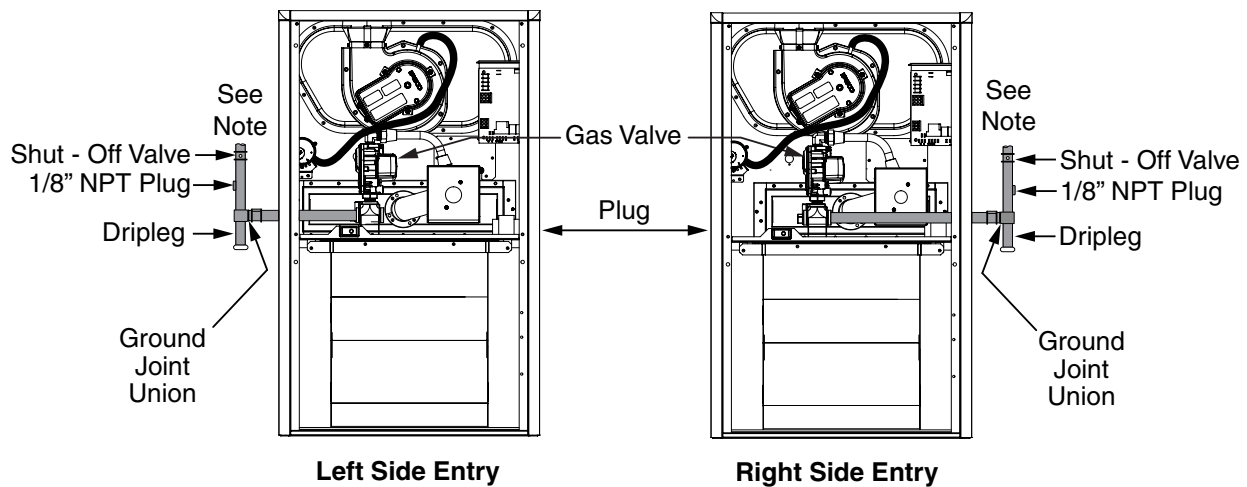

Figure 11. Alternate Removal Method

WARNING:

THE FURNACE IS EQUIPPED TO RUN ON NATURAL GAS ONLY. AN LP/PROPANE CONVERSION KIT IS NOT AVAILABLE. USE OF LP/PROPANE WITH THIS FURNACE CAN CAUSE FIRE, EXPLOSION, PROPERTY DAMAGE, CARBON MONOXIDE POISONING, PERSONAL INJURY, OR DEATH.

- All gas piping must be installed in compliance with local codes and utility regulations. In the absence of local codes the gas line installation must comply with the latest edition of the National Fuel Gas Code (ANSI Z223.1) Installation Codes.
- Some local regulations require the installation of a manual main shut-off valve and ground joint union external to the furnace as shown in [Figure 12](#), (page 13). The shut-off valve should be readily accessible for service and/or emergency use. Consult the local utility or gas supplier for additional requirements regarding placement of the manual main gas shut-off.
- Per ANSI 21.47, A 1/8-inch NPT plugged tapping, accessible for test gauge connection, must be installed immediately upstream of the gas supply connection to the furnace external to the cabinet. If local codes allow the use of a flexible gas appliance connector, always use a new listed connector. Do not use a connector that has previously serviced another gas appliance.
- Gas piping must never run in or through air ducts, chimneys, gas vents, or elevator shafts.
- Compounds used on threaded joints of gas piping must be resistant to the actions of LP propane gas.



NOTE: Some utilities require Shut - Off Valve to be 4 - 5 feet above floor.

Figure 12. Typical Gas Connections

- The main gas valve and main power disconnect to the furnace must be properly labeled by the installer in case emergency shutdown is required.
- Flexible gas connectors are not recommended for this type of furnace but may be used if allowed by local jurisdiction. Only new flexible connectors may be used. Do not use a connector which has previously serviced another gas appliance.
- A drip leg should be installed in the vertical pipe run to the unit (Figure 12).

Table 7, (page 26) lists gas pipe capacities for standard pipe sizes as a function of length in typical applications based on nominal pressure drop in the line.

The furnace may be installed for either left or right side gas entry by removing the 1/2" plug from the tee and replacing it to the side not used. When connecting the gas supply, provide clearance between the gas supply line and the entry hole in the furnace casing to avoid unwanted noise and/or damage to the furnace. Typical gas hookups are shown in Figure 12.

Leak Check

⚠ WARNING:

FIRE OR EXPLOSION HAZARD
Failure to follow safety warnings exactly could result in serious injury, death or property damage.

Never test for gas leaks with an open flame. Use a commercially available soap solution made specifically for the detection of leaks to check all connections. A fire or explosion may result causing property damage, personal injury or loss of life.

After the gas piping to the furnace is complete, all connections must be tested for gas leaks. This includes pipe connections at the main gas valve, emergency shutoff valve and flexible gas connectors (if applicable). The soap and water solution can be applied on each joint or union using a small paintbrush.

If any bubbling is observed, the connection is not sealed adequately and must be retightened. Repeat the tightening and soap check process until bubbling ceases.

IMPORTANT NOTE:

When pressure testing gas supply lines at pressures greater than 1/2 psig (14 inch W.C.), the gas supply piping system must be disconnected from the furnace to prevent damage to the gas control valve. If the test pressure is less than or equal to 1/2 psig (14 inch W.C.), close the manual shut-off valve.

High Altitude Application

High altitude conversion with this furnace depends on the installation altitude and the heating value of the gas. Installation of this furnace at altitudes above 2,000 feet shall be in accordance with local codes, or in the absence of local codes, the National Fuel Gas Code, ANSI Z223.1/NFPA 54. Please consult your local code authority.

⚠ WARNING:

The reduction of input rating necessary for high altitude installation may only be accomplished with factory supplied orifices. Do not attempt to drill out orifices in the field. Improperly drilled orifices may cause fire, explosion, carbon monoxide poisoning, personal injury or death.

The furnaces are shipped from the factory with orifices and gas regulator settings for natural gas operation at sea level altitudes. At 2,000 feet, the NFGC requires that this appliance be derated 4% for each 1,000 feet of altitude. For example, at 2,000 feet the input needs to be reduced 8%, at 3,000 feet (12%), etc. This deration is in reference to the input rate and gas heating value at sea level.

To derate the furnace requires knowing the heating value of the gas at the installation site. Heating values at particular job sites vary for two reasons:

1. The chemical mixture of the gas varies across regions and is expressed as the "sea level heating value".
2. The heating value varies by altitude. For this reason, especially in high altitude areas, the local gas utility

specifies the heating value at the residence's gas meter as the "local value".

For added flexibility, two tables have been provided for natural gas installations with HIGH or LOW heating values at sea level. [Table 9](#) & [Table 10](#), (page 27) contain the orifice sizes and manifold pressure to use at various altitudes. [Table 9](#) (High) is for natural gas installations with a heating value of more than 1,000 Btu per cubic foot and [Table 10](#) (Low) is for less than 1,000 Btu per cubic foot. To determine which table to use:

1. Consult the local utility for the local heating value at your installation site.
2. From [Table 8](#), (page 27), find your local heating value as supplied by the utility company. Follow down the column and stop at your altitude level.
3. If your sea level heating value is HIGH, use [Table 9](#) or if it's LOW, use [Table 10](#).

EXAMPLE	
Elevation:	5,000 feet
Type of Gas:	Natural Gas
Local Heating Value of Gas:	750
From Table 8 , find 750 and follow down the column, stop at the 5,000 feet row. The heating value listed is LOW. Table 10 will be used to determine orifice size and manifold pressure	

After changing the regulator pressure or the orifices, it is required that you measure the gas input rate. This may be accomplished in the usual way, by clocking the gas meter and using the local gas heating value. See [Verifying and Adjusting the Input Rate](#) section ([page 16](#)).

IMPORTANT NOTE:

Observe operation of the furnace to make sure there are no abnormal noises at ignition or during steady state operation.

ELECTRICAL WIRING

<p>⚠ WARNING:</p> <p>ELECTRICAL SHOCK, FIRE OR EXPLOSION HAZARD</p> <p>Failure to follow safety warnings exactly could result in serious injury, death or property damage.</p> <p>Improper servicing could result in dangerous operation, serious injury, death or property damage.</p> <ul style="list-style-type: none"> • Before servicing, disconnect all electrical power to furnace. • When servicing controls, label all wires prior to disconnecting. Reconnect wires correctly. • Verify proper operation after servicing.
--

- Electrical connections must be in compliance with all applicable local codes and the current revision of the National Electric Code (ANSI/NFPA 70).

Line Voltage Wiring

It is required that the line voltage (120 VAC) to the furnace be supplied from a dedicated branch circuit containing the correct fuse or circuit breaker for the furnace. See [Table 1](#).

IMPORTANT NOTES:

- An electrical disconnect must be installed readily accessible from and located within sight of the furnace. See [Figure 14](#) or the wiring diagram label inside of the control door. Any other wiring methods must be acceptable to authority having jurisdiction.
- Proper line voltage polarity must be maintained in order for the control system to operate correctly. Verify the incoming neutral line is connected to the white wire and the incoming "hot" line is connected to the black wire. The furnace will not operate unless the polarity and ground are properly connected as shown in [Figure 14](#), (page 15).
- If replacing any of the original wires supplied with the furnace, the replacement wire must be copper wiring and have a temperature rating of at least 105° F (40° C). For electrical specifications, refer to the furnace nameplate or [Table 1](#), (page 15).

Grounding

⚠ WARNING:

To minimize personal injury, the furnace cabinet must have an uninterrupted or unbroken electrical ground. The controls used in this furnace require an earth ground to operate properly. Acceptable methods include electrical wire or conduit approved for ground service. Do not use gas piping as an electrical ground!

Thermostat / Low Voltage Connections

- The furnace is designed to be controlled by a 24 VAC thermostat. The thermostat's wiring must comply with the current provisions of the NEC (ANSI/NFPA 70) and with applicable local codes having jurisdiction.
- The thermostat must be installed according to the instructions supplied by the thermostat manufacturer. Low voltage connections (24 VAC) from the thermostat

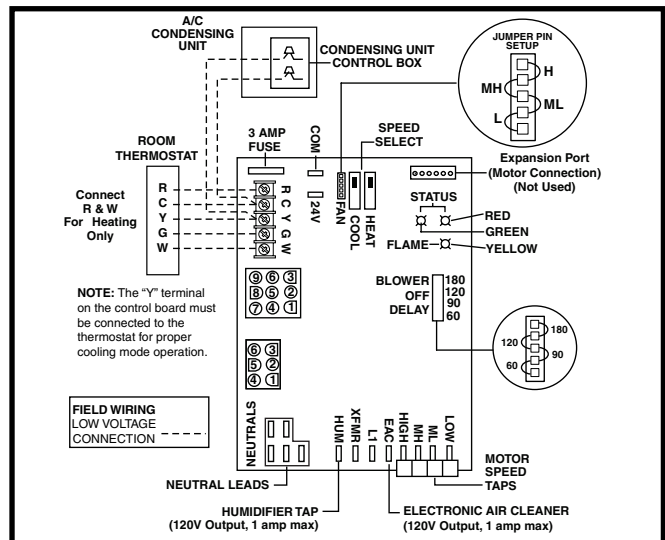

Figure 13. Low Voltage Connections

FURNACE MODEL *SA-	FURNACE INPUT (BTUH)	CABINET WIDTH (IN.)	NOMINAL ELECTRICAL SUPPLY	MAXIMUM OPERATING VOLTAGE	MINIMUM OPERATING VOLTAGE (†)	MAXIMUM FURNACE AMPERES	MINIMUM CIRCUIT AMPACITY (MCA)	MAXIMUM FUSE OR CIRCUIT BREAKER AMPS*
-055U-T23A*	55,000	14 1/4	120-60-1	132	108	7.2	8.73	15
-070U-T24B*	70,000	17 1/2	120-60-1	132	108	9.5	11.60	20
-100U-T35C*	100,000	21	120-60-1	132	108	12.1	14.85	25

* Time-delay fuses or HACR rated circuit breakers are recommended. † At 108V operating voltage, the unit may not operate properly.

THERMOSTAT WIRE GAUGE	RECOMMENDED THERMOSTAT WIRE LENGTH	
	2 - WIRE - HEATING	4 OR 5 WIRE - COOLING
24	55 ft.	25 ft.
22	90 ft.	45 ft.
20	140 ft.	70 ft.
18	225 ft.	110 ft.

Table 1. Electrical Specifications

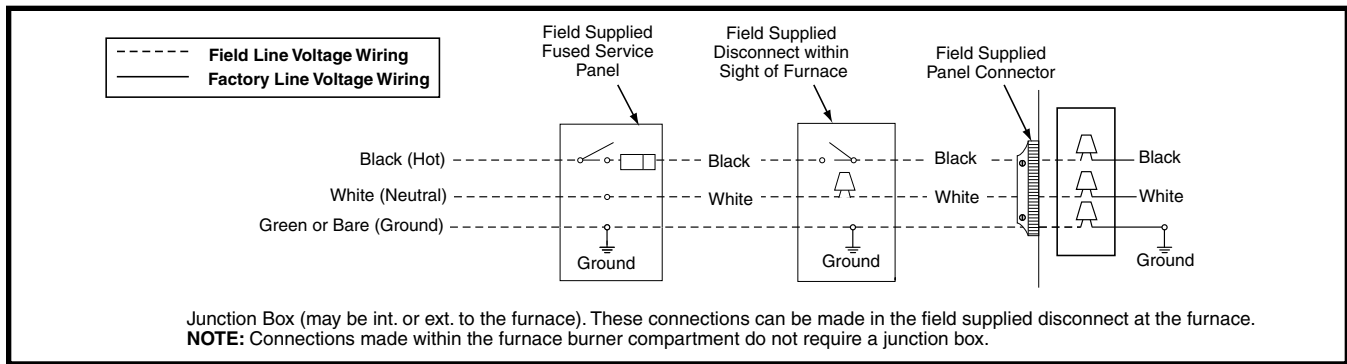

Figure 14. Line Voltage Field Wiring

are wired to the terminal strip on the integrated control in the furnace. Figure 13 contains the proper connections for heating only (two-wire) and heating/cooling (four-wire) applications.

- The thermostat should be mounted about 5 feet above the floor on an inside wall. DO NOT install the thermostat on an outside wall or any other location where its operation may be adversely affected by radiant heat from fireplaces, sunlight, or lighting fixtures, and convective heat from warm air registers or electrical appliances. Refer to the thermostat manufacturer's instruction sheet for detailed mounting information.
- The six pin terminal marked "Expansion Port" (Figure 13, page 14) is not used in the single stage furnace as shipped from the factory. It is used for the furnace control board to communicate to a fixed speed or variable speed high efficiency motor that may be optionally installed. Please contact your distributor for the proper upgrade motor kit.

Heat Anticipator

Set the heat anticipator according to the instructions supplied by the thermostat manufacturer. To determine the heat anticipator setting:

- Add the current draw of the system components; or
- Measure the current flow on the thermostat R-W circuit after the circulating blower motor has started.

START-UP & ADJUSTMENTS

Pre-Start Check List

- ✓ Verify the polarity of the connections are correct, the line voltage power leads are securely connected and the furnace is properly grounded.
- ✓ Verify the thermostat wires (R, W, Y, & G) are securely connected to the correct leads on the terminal strip of the circuit board.
- ✓ Verify the jumper setting (for fan speed) on the control board. See Figure 13, (page 14).
- ✓ Verify the gas line service pressure does not exceed 10.0 inches of W.C., and is not less than 4.5 inches W.C. for natural gas.
- ✓ Verify the blocked vent switch is closed (if manual reset type). If necessary, press the red button to reset a switch. DO NOT install a jumper wire across a switch to defeat its function. If a switch reopens on startup, DO NOT reset the switch without identifying and correcting the fault condition.
- ✓ Verify the blower door is in place, closing the door switch in the line voltage circuit.
- ✓ Verify the gas line has been purged and all connections are leak free.

Start-up Procedures

Do not perform these steps until all of the checks in the previous steps have been completed:

- Set the thermostat to the lowest setting.
- Turn off all electrical power to the furnace.
- Follow the Operating Instructions on the label attached to the furnace.
- Set the thermostat above room temperature and verify the Operating Sequence (page 17).

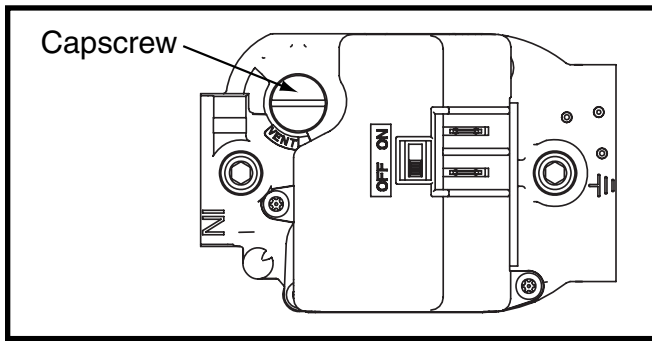

Figure 15. Regulator Capscrew

- After 5 minutes of operation, set the thermostat below room temperature and verify steps 9 - 10 of the Operating Sequence.

Verifying & Adjusting Input Rate

The input rate must be verified for each installation to prevent over-firing of the furnace. **NOTE:** The input rate must not exceed the rate shown on the furnace rating plate. At altitudes above 2,000 feet, it must not exceed that on the rating plate less 4% for each 1,000 feet. To determine the exact input rate, perform the following procedures:

- Shut off all other gas fired appliances.
- Start the furnace and run it for at least 3 minutes.
- Measure the time (in seconds) required for the gas meter to complete one revolution.
- Convert the time per revolution to cubic feet of gas per hour using [Table 7](#), (page 26).
- Multiply the gas flow rate in cubic ft per hr by the heating value of the gas in Btu per cubic ft to obtain the input rate in Btuh. See [Example](#).

EXAMPLE

- Time for 1 revolution of a gas meter with a 1 cubic ft dial = 40 seconds.
- From [Table 7](#) read 90 cubic ft gas per hr.
- Local heating value of the gas (obtained from gas supplier) = 1,040 Btu per cubic ft.
- Input rate = 1,040 x 90 = 93,600 Btuh.

⚠ WARNING:

Do not attempt to drill the gas orifices. Use only factory supplied orifices. Improperly drilled orifices may cause fire, explosion, carbon monoxide poisoning, personal injury or death.

- Obtain the manifold pressure setting required for this installation by referring to [Table 9](#) or [Table 10](#), (page 27).

The manifold pressure must be set to the appropriate value for each installation by a qualified installer, service agency or the gas supplier.

- Remove the regulator capscrew from the INLET side of the regulator. See ([Figure 15](#)).
- Slowly turn the adjustment screw inside the regulator to obtain the appropriate manifold pressure.

NOTE: Turning the screw clockwise increases the pressure and turning the screw counter-clockwise decreases the

pressure. To prevent backing the screw all the way out from the valve, turn the screw slowly.

- Replace and tighten the regulator capscrew over the adjustment screw.

Verifying & Adjusting Temperature Rise

After installation of the furnace, confirm the temperature rise of the furnace is within the limits specified on the rating plate. Any temperature rise outside the specified limits could result in premature failure of the heat exchanger.

- Place thermometers in the return and supply air stream as close to the furnace as possible. The thermometer on the supply air side must be shielded from direct radiation from the heat exchanger to avoid false readings.
- Adjust all registers and duct dampers to the desired position and run the furnace for 10 to 15 minutes before taking any temperature readings. The temperature rise is the difference between the supply and return air temperatures.

For typical duct systems, the temperature rise will fall within the limits specified on the rating plate with the blower speed at the factory recommended setting. If the measured temperature rise is outside the specified limits, it may be necessary to change the speed of the blower. **NOTE:** Lowering the blower speed will increase the temperature rise and a higher blower speed will decrease the temperature rise.

The furnace is equipped with a multi-speed motor. Heating, cooling, and fan speed selection is made by moving the switch on the integrated control located in the furnace.

Verifying Burner Operation

⚠ CAUTION:

The door over the burners may only be open for inspection purposes only. The door must be installed during unattended operation.

- Remove the burner compartment door and note the location of the sightglass on burner head.
- Set the thermostat above room temperature and observe the ignition sequence. **NOTE:** The burner flame should be present by seeing a glow through the sightglass.
- After validating the flame, change the thermostat setting to below room temperature.
- Verify the burner flame is completely extinguished.
- Replace the burner compartment door.

Verify Operation of the Supply Air Limit Switch

A properly functioning limit switch should turn off the gas valve when the return is blocked (time depends on how well the return air is blocked). The circulating air and combustion blowers should continue to run when the limit switch opens.

- Verify the blower door is securely mounted in place and that there is power to the furnace.
- Block the return airflow to the furnace by installing a close-off plate in place of or upstream of the filter(s).
- Set the thermostat above room temperature and observe the Operating Sequence.
- Remove the close-off immediately after the limit switch opens. If the furnace continues to operate with no return air, set the thermostat below room temperature, shut off power to the furnace, and replace the limit switch.

OPERATING SEQUENCE

The operating sequences for the heating, cooling, and fan modes are described below. Refer to the field and furnace wiring diagrams: [Figure 14, \(page 15\)](#), [Figure 19, \(page 24\)](#), and [Figure 20, \(page 25\)](#).

Heating Cycle

1. The thermostat calls for heat by energizing the **W** terminal with 24VAC.
2. The control verifies the safety circuit pressure switch is open and high temperature limit switch circuit is closed.
3. If the pressure switch is open, the control energizes the inducer and waits for the pressure switch to close. The pressure switch must close within 10 seconds.
4. The control runs the inducer for a 30 second pre-purge.
5. The control energizes the igniter output for a 30 second warm-up period.
6. The control energizes the main gas valve for 3 seconds.
7. If the flame is proved after igniting the gas, the control de-energizes the igniter. The gas valve and inducer remain energized. The control goes to blower on delay.
8. If flame is present, the control energizes the blower on the selected HEAT speed 30 seconds after the gas valve opened. The gas valve remains energized while the inducer ramps to Max. RPM over a programmed time period.
9. When the thermostat demand for heat is satisfied, the control de-energizes the gas valve. The inducer output remains on for a 30 second post-purge period.
10. Blower off timing of 60, 90, 120, & 180 seconds (depending on the movable jumper setting) begins when the thermostat is satisfied. See [Figure 14 \(page 16\)](#). The control will operate at the selected HEAT speed of 60 seconds, then change to FAN speed for the remaining off delay time. If the blower off delay jumper is not present, the fan should still operate for 120 seconds at the selected HEAT speed. The indoor blower motor is de-energized after a blower off delay as selected by the movable jumper.

Cooling Cycle

1. The thermostat calls for cooling by energizing the **Y & G** terminal with 24VAC.
2. The control energizes the blower in the cooling speed and sends 24VAC to the contactor in the condensing unit.
3. When the thermostat removes the call for cooling, the contactor in the outdoor condensing unit is de-energized and the control continues to run the fan for a period of 60 seconds.

Fan Mode

- When the thermostat energizes the **G** terminal for continuous fan (without calling for heat or cooling), the indoor fan is energized on the selected FAN speed. See [Figure 13, \(page 14\)](#). The control defaults to MEDIUM HIGH if the movable jumper is not attached.
- If a call for cooling occurs during continuous fan, the blower will switch over to the selected COOL speed.
- If the **W** terminal receives a call for heat during continuous fan, the blower will de-energize and reset to delayed ON timing.
- A call for fan is ignored while in lockout.

MAINTENANCE

WARNING:

ELECTRICAL SHOCK, FIRE OR EXPLOSION HAZARD

Failure to follow safety warnings exactly could result in serious injury, death or property damage.

Improper servicing could result in dangerous operation, serious injury, death or property damage.

- **Before servicing, disconnect all electrical power to furnace.**
- **When servicing controls, label all wires prior to disconnecting. Reconnect wires correctly.**
- **Verify proper operation after servicing.**

Proper maintenance is most important to achieve the best performance from a furnace. Follow these instructions for years of safe, trouble free operation.

- These maintenance instructions are primarily intended to assist qualified technicians experienced in the proper maintenance and operation of this appliance.
- Always reinstall the doors on the furnace after servicing or cleaning/changing the filters. Do not operate the furnace without all doors and covers in place.
- Verify the thermostat is properly installed and is not being affected by drafts or heat from lamps or other appliances.
- To achieve the best performance and minimize equipment failure it is recommended that a yearly maintenance checkup be performed. At a minimum, this check should include the following items:

Air Filter - An air filter is not supplied with the furnace as shipped from the factory. The installer must provide a high velocity filter that is appropriately sized to the return air duct opening or external filter rack.

WARNING:

Never operate the furnace without a filter in place. Dust and lint can build up on internal components, resulting in loss of efficiency, equipment damage, and possible fire.

It is recommended that filter(s) be 1" or 2" thick and be cleaned or replaced monthly. New or newly renovated homes may require more frequent changing until the construction dust has minimized.

Filters designed to remove smaller particles such as pollen, may require additional maintenance. Filters for side return and bottom return applications are available from most local distributors.

Blower Compartment - Dirt and lint can create excessive loads on the motor resulting in higher than normal operating temperatures and shortened service life. It is recommended that the blower compartment be cleaned of dirt or lint that may have accumulated in the compartment or on the blower and motor as part of the annual inspection.

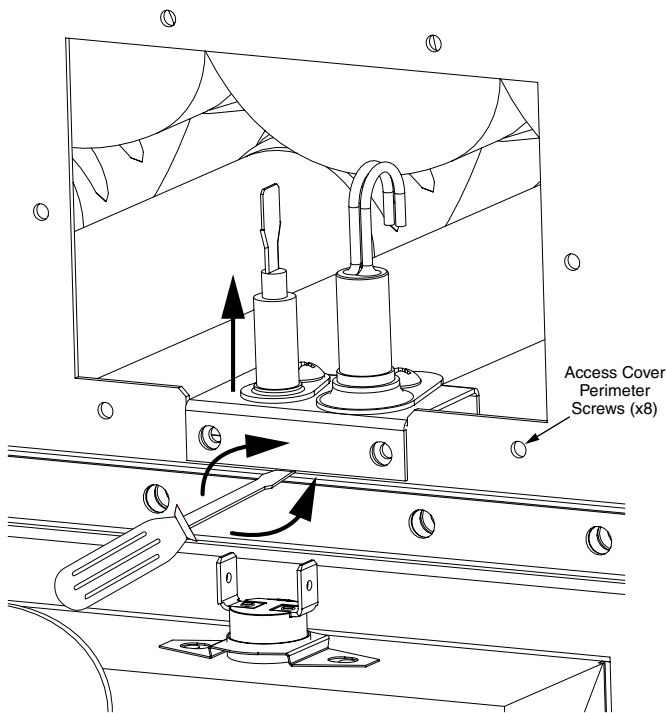

Figure 16. Ignitor Flame Sensor Bracket

Cleaning of Flame Sensor - If the flame sensor is suspect for Loss of Flame fault code, the sensor can be cleaned to see if that remedies the issue. Follow steps 1 - 10. See [Figure 17, \(page 19\)](#) for component location.

⚠ CAUTION:

Due to igniter/flame sensor assembly location, a new gasket should be on hand before servicing this part. One new gasket is provided in the furnace extra parts package. Failure to re-seal the assembly after service can result in abnormal furnace operation.

1. Shut off gas supply to the furnace at the meter or at a manual valve in the supply piping.
2. Turn off all power to the furnace and set the thermostat to its lowest setting.
3. Remove the louvered door from the furnace.
4. Turn the gas control switch to the OFF position.
5. Remove the 2 screws securing the combustion air orifice plate to the air/fuel mixing tube (if needed to access the ignitor/flame sensor assembly cover on smaller models).
6. Remove 8 screws from perimeter of access cover plate.
7. Lift the assembly and bracket straight up out of the burner box and off the HX panel. **NOTE:** Use of a flat blade screwdriver between assembly bracket and top of burner mounting bracket to help leverage bracket off may be required. See [Figure 16](#).
8. Clean the flame sensor using steel wool being careful not to damage the igniter.
9. Replace old gasket with new gasket ensuring correct orientation, with adhesive side to the bracket.
10. Replace igniter/flame sense assembly in reverse order they were removed.

Vent System - Check the vent pipe and/or chimney for corrosion or debris. Any corroded section of vent pipe must be replaced, and any obstruction or blockage must be removed prior to operating the furnace.

⚠ WARNING:

Holes in the vent pipe or heat exchanger can cause combustion products to enter the home. Replace the vent pipe or heat exchanger if leaks are found. Failure to prevent the circulation of combustion products into the living space can create potentially hazardous conditions including carbon monoxide poisoning that could result in personal injury or death.

Heat Exchanger & Burner Maintenance - The furnace should operate for many years without soot buildup in the flue passageways, however, the flue and vent system should be inspected and cleaned (if required) by a qualified service technician annually to ensure continued safe operation. Pay attention to any deterioration from corrosion or other sources.

Lubrication - The bearings in the blower motor and inducer blower used in these furnaces are pre-lubricated and sealed by the manufacturer. No further oiling of the bearings is required for the life of the motor.

TROUBLESHOOTING

If the furnace fails to operate check the following:

- Is the thermostat operating properly?
- Is the blower compartment doors in place?
- Is the furnace disconnect closed?
- Has the circuit breaker tripped or the control board fuse burned open?
- Is the gas turned on?
- Are any manual reset switches open?
- Is the filter dirty or plugged?
- Is the flame sensor coated? (Remove and clean with steel wool. New gasket is required) See [Cleaning of Flame Sensor](#) section [page 18](#).
- Are all the LED's on the furnace control board constantly ON? If not, refer to [Table 2](#) or the wiring diagrams ([Figure 19, \(page 24\)](#)) and [Figure 20, \(page 25\)](#) to determine fault condition.

DIAGNOSTIC DESCRIPTION	GREEN LED	RED LED
Control Fault (No Power)	Off	Off
L1/Neutral Polarity Fault	Flash	Flash
1 Hour Lockout	Alternating Flash	
Normal Operation	On	On
Pressure Switch Closed Fault	On	Flash
Pressure Switch Open Fault	Flash	On
Open Limit Switch Fault	Flash	Off
DIAGNOSTIC DESCRIPTION	YELLOW LED	
Low Flame Sensor Signal	Continuous Flash	
Flame Present	On	

Table 2. Control Board Fault Conditions

IMPORTANT NOTE: The furnace will lock out after 5 failed attempts for ignition and will try again every hour if the call for heat remains.

- If the inducer blower is operating and items above have been verified, check the limit switch circuit and reset if necessary. See [Figure 17, \(page 19\)](#) for component location.
- If the furnace operates when the limit switch circuit is reset, contact a qualified service technician to identify and repair the problem.
- If the furnace still doesn't operate, check the flame roll-out switch and reset if necessary. See [Figure 17](#) for component location.
- If the furnace operates when the flame rollout switch is reset, contact a qualified service technician to identify and repair the problem.

FURNACE COMPONENTS

The descriptions below are various functional components that affect the operation and shutting down of this furnace. Some of these components and their locations are shown in [Figure 17](#). If any component of the furnace must be replaced, use only factory authorized replacement parts specified in the Replacement Parts List.

Blower Limit Switch (Reverse Airflow Limit) - Prevents operation when blower is not operational.

Flame Sensor - Verifies when a flame is present. If no flame is detected, the furnace will shut down within 4 seconds.

Gas Valve - Controls the flow of gas to the burners. When the gas valve is energized it automatically opens and regulates the gas pressure in the manifold.

Inducer Assembly - Vents products of combustion to the outside.

Pressure Switch - Verifies that the inducer is drawing the combustion gases through the heat exchanger. The pressure switch prevents furnace operation with excessive flue blockage or improper inducer operation.

Primary Air Limit Switch - Prevents the air temperature leaving the furnace from exceeding the maximum allowable outlet air temperature.

Blocked Vent Limit Switch - Verifies the inducer is drawing combustion gases through the heat exchanger properly. The temperature switch prevents furnace operation in the event of flue or combustion air passageway blockage, or improper inducer operation. If the blocked vent switch opens, the gas valve will close and initiate the shutdown cycle. The blower will run continuously due to open limit fault.

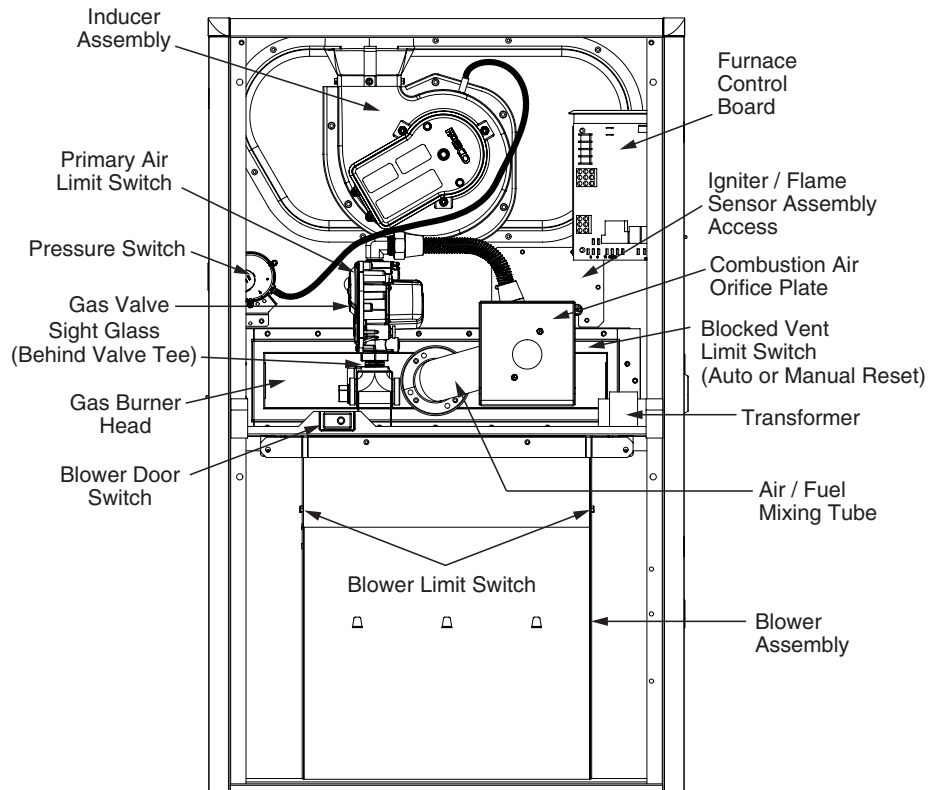

Figure 17. Component Locations

FIGURES & TABLES

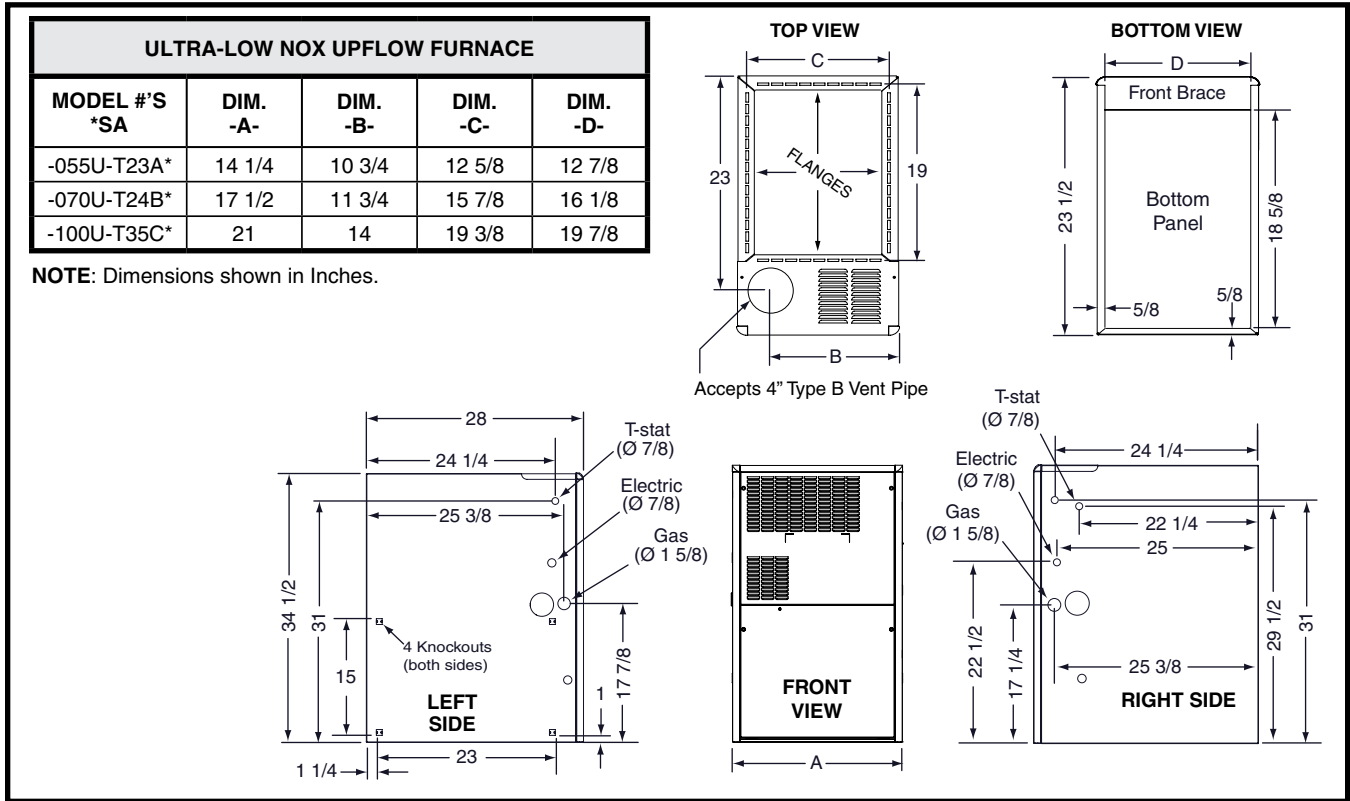

Figure 18. Furnace Dimensions

Airflow Data

HEATING AIRFLOW (CFM) & TEMPERATURE RISE (°F)												
MODEL NAME/ HEATING INPUT *SA-	RETURN AIR VIA:	MOTOR SPEED TAP	EXTERNAL STATIC PRESSURE (IN. W.C.)									
			0.1		0.2		0.3		0.4		0.5	
			CFM	RISE	CFM	RISE	CFM	RISE	CFM	RISE	CFM	RISE
-055U-T23A* 55,000 BTU/Hr	Bottom	5 - High*										
		4 - Med-High										
		3 - Med-Low**	880	46	845	48	810	50	770	53	735	55
		2 - Alternate	705	58	650	63	610		570		530	
		1 - Low***	640	64	600		555		510		470	
	Side	5 - High*										
		4 - Med-High										
		3 - Med-Low**	875	47	830	49	793	51	752	54	715	57
		2 - Alternate	685	60	650	63	595		555		514	
		1 - Low***	640	64	585		540		500		460	

COOLING AIRFLOW (CFM)										
MODEL NAME/ HEATING INPUT *SA-	RETURN AIR VIA:	MOTOR SPEED TAP	EXTERNAL STATIC PRESSURE (IN. W.C.)							
			0.1	0.2	0.3	0.4	0.5	0.6	0.7	0.8
			CFM	CFM	CFM	CFM	CFM	CFM	CFM	CFM
-055U-T23A* 55,000 BTU/Hr	Bottom	5 - High*	1,180	1,140	1,110	1,080	1,055	1,015	985	955
		4 - Med-High	920	880	850	810	775	740	700	665
		3 - Med-Low**	880	845	810	770	735	700	665	630
		2 - Alternate	705	650	610	570	530	480	440	400
		1 - Low***	640	600	555	510	470	430	390	340
	Side	5 - High*	1,160	1,125	1,095	1,065	1,040	1,010	975	945
		4 - Med-High	905	860	827	790	755	717	683	639
		3 - Med-Low**	875	830	793	752	715	684	642	606
		2 - Alternate	685	650	595	555	515	471	424	376
		1 - Low***	640	585	540	500	460	415		

***NOTES:**

- Special consideration should be taken in duct design, evaporator coil selection / pressure drop, and air filter selection to achieve 350 CFM/ton at 0.5" external static pressure.
- To comply with government mandated efficiency standards, two openings are required for airflows above 1,600 CFM.
- Data is shown without filter.
- Temperature rises in the table are approximate. Actual temperature rises may vary.
- Individual cells shaded in gray indicate a temperature rise outside of the recommended range.
- To comply with government mandated efficiency standards, speed settings shaded in gray are not allowed in HEAT mode.
- *Denotes the factory cool setting, **denotes the factory heat setting, and *** denotes factory fan setting. If the Alternate speed is to be used, the speed tap must be adjusted at the blower motor plug.

Table 3. Blower Data for *SA-055U-T23A* Models

HEATING AIRFLOW (CFM) & TEMPERATURE RISE (°F)												
MODEL NAME/ HEATING INPUT *SA-	RETURN AIR VIA:	MOTOR SPEED	External Static Pressure (in. w.c.)									
			0.1		0.2		0.3		0.4		0.5	
			CFM	RISE	CFM	RISE	CFM	RISE	CFM	RISE	CFM	RISE
-070U-T24B1 70,000 BTU/Hr	Bottom	5 - High*										
		4 - Alternate										
		3 - Medium High										
		2 - Med-Low**	1,130	46	1,070	48	1,010	51	960	54	890	58
		1 - Low***	820	63	730		630		570		540	
	Side	5 - High*										
		4 - Alternate										
		3 - Medium High										
		2 - Med-Low**	1,090	48	1,020	51	970	53	920	56	860	60
		1 - Low***	740		680		620		560		510	

COOLING AIRFLOW (CFM)										
MODEL NAME/ HEATING INPUT *SA-	RETURN AIR VIA:	MOTOR SPEED	External Static Pressure (in. w.c.)							
			0.1	0.2	0.3	0.4	0.5	0.6	0.7	0.8
			CFM	CFM	CFM	CFM	CFM	CFM	CFM	CFM
-070U-T24B1 70,000 BTU/Hr	Bottom	5 - High*	1,790	1,740	1,690	1,640	1,590	1,540	1,490	1,440
		4 - Alternate	1,650	1,590	1,560	1,500	1,450	1,400	1,350	1,290
		3 - Medium High	1,395	1,340	1,290	1,235	1,190	1,130	1,070	1,010
		2 - Med-Low**	1,130	1,070	1,010	960	890	820	770	720
		1 - Low***	820	730	630	570	540	490	430	380
	Side	5 - High*	1,740	1,700	1,660	1,610	1,550	1,510	1,460	1,400
		4 - Alternate	1,610	1,550	1,510	1,460	1,410	1,360	1,310	1,250
		3 - Medium High	1,350	1,295	1,245	1,185	1,140	1,085	1,035	985
		2 - Med-Low**	1,090	1,020	970	920	860	800	750	700
		1 - Low***	740	680	620	560	510	450	410	360

***NOTES:**

1. Special consideration should be taken in duct design, evaporator coil selection / pressure drop, and air filter selection to achieve 350 CFM/ton at 0.5" external static pressure.
2. To comply with government mandated efficiency standards, two openings are required for airflows above 1,600 CFM.
3. Data is shown without filter.
4. Temperature rises in the table are approximate. Actual temperature rises may vary.
5. Individual cells shaded in gray indicate a temperature rise outside of the recommended range.
6. To comply with government mandated efficiency standards, speed settings shaded in gray are not allowed in HEAT mode.
7. The * denotes the factory COOL setting, ** denotes the factory HEAT setting, and *** denotes factory FAN setting. If the Alternate speed is to be used, the speed tap must be adjusted at the blower motor plug.

Table 4. Blower Data for *SA-070U-T24B* Models

HEATING AIRFLOW (CFM) & TEMPERATURE RISE (°F)												
MODEL NAME/ HEATING INPUT *SA-	RETURN AIR VIA:	MOTOR SPEED TAP	EXTERNAL STATIC PRESSURE (IN. W.C.)									
			0.1		0.2		0.3		0.4		0.5	
			CFM	RISE	CFM	RISE	CFM	RISE	CFM	RISE	CFM	RISE
-100U-T35C* 100,000 BTU/Hr	Bottom	5 - High*										
		4 - Med-High										
		3 - Med-Low**	1,580	47	1,530	48	1,480	50	1,420	0	1,360	54
		2 - Alternate	1,500	49	1,450	51	1,400	53	1,340	55	1,280	58
		1 - Low***	1,390	53	1,320	56	1,260	59	1,200	62	1,130	
	Side Only	5 - High*										
		4 - Med-High										
		3 - Med-Low**	1,540	48	1,490	50	1,440	51	1,380	54	1,330	56
		2 - Alternate	1,470	50	1,420	52	1,360	54	1,310	57	1,260	59
		1 - Low***	1,310	57	1,250	59	1,190	62	1,150	64	1,080	
	Side + Bottom or 2 sides	5 - High*										
		4 - Med-High										
		3 - Med-Low**	1,600	46	1,530	48	1,460	51	1,400	53	1,340	55
		2 - Alternate	1,525	49	1,455	51	1,390	53	1,330	56	1,265	59
		1 - Low***	1,370	54	1,300	57	1,230	60	1,150	64	1,090	

COOLING AIRFLOW (CFM)										
MODEL NAME/ HEATING INPUT *SA-	RETURN AIR VIA:	MOTOR SPEED TAP	EXTERNAL STATIC PRESSURE (IN. W.C.)							
			0.1	0.2	0.3	0.4	0.5	0.6	0.7	0.8
			CFM	CFM	CFM	CFM	CFM	CFM	CFM	CFM
-100U-T35C* 100,000 BTU/Hr	Bottom	5 - High*	2,310	2,260	2,200	2,150	2,100	2,040	1,990	1,940
		4 - Med-High	1,870	1,820	1,760	1,720	1,670	1,610	1,560	1,490
		3 - Med-Low**	1,580	1,530	1,480	1,420	1,360	1,290	1,230	1,155
		2 - Alternate	1,500	1,450	1,400	1,340	1,280	1,210	1,130	1,050
		1 - Low***	1,390	1,320	1,260	1,200	1,130	1,060	970	890
	Side Only	5 - High*	2,160	2,100	2,060	2,020	2,050	1,990	1,950	1,880
		4 - Med-High	1,810	1,750	1,710	1,660	1,620	1,560	1,510	1,440
		3 - Med-Low**	1,540	1,490	1,440	1,380	1,330	1,270	1,210	1,150
		2 - Alternate	1,470	1,420	1,360	1,310	1,260	1,200	1,130	1,070
		1 - Low***	1,310	1,250	1,190	1,150	1,080	1,000	950	880
	Side + Bottom or 2 sides	5 - High*	2,280	2,220	2,170	2,120	2,090	2,080	2,020	1,950
		4 - Med-High	1,880	1,820	1,770	1,720	1,670	1,610	1,560	1,490
		3 - Med-Low**	1,600	1,530	1,460	1,400	1,340	1,270	1,200	1,120
		2 - Alternate	1,525	1,455	1,390	1,330	1,265	1,190	1,120	1,045
		1 - Low***	1,370	1,300	1,230	1,150	1,090	1,000	920	860

***NOTES:**

1. Special consideration should be taken in duct design, evaporator coil selection / pressure drop, and air filter selection to achieve 350 CFM/ton at 0.5" external static pressure.
2. To comply with government mandated efficiency standards, two openings are required for airflows above 1,600 CFM.
3. Data is shown without filter.
4. Temperature rises in the table are approximate. Actual temperature rises may vary.
5. Individual cells shaded in gray indicate a temperature rise outside of the recommended range.
6. To comply with government mandated efficiency standards, speed settings shaded in gray are not allowed in HEAT mode.
7. *Denotes the factory cool setting, **denotes the factory heat setting, and *** denotes factory fan setting. If the Alternate speed is to be used, the speed tap must be adjusted at the blower motor plug.

Table 5. Blower Data for *SA-100U-T35C* Models

Gas Information

GAS FLOW RATES (CUBIC FEET PER HOUR)			
TIME FOR ONE REVOLUTION (SECONDS)	CUBIC FEET PER REVOLUTION OF GAS METER		
	1	5	10
10	360	1,800	3,600
12	300	1,500	3,000
14	257	1,286	2,571
16	225	1,125	2,250
18	200	1,000	2,000
20	180	900	1,800
22	164	818	1,636
24	150	750	1,500
26	138	692	1,385
28	129	643	1,286
30	120	600	1,200
32	113	563	1,125
34	106	529	1,059
36	100	500	1,000
38	95	474	947
40	90	450	900
42	86	429	857
44	82	409	818
46	78	391	783
48	75	375	750
50	72	360	720
52	69	346	692
54	67	333	667
56	64	321	643
58	62	310	621
60	60	300	600
62	58	290	581
64	56	281	563

GAS FLOW RATES (CUBIC FEET PER HOUR)			
TIME FOR ONE REVOLUTION (SECONDS)	CUBIC FEET PER REVOLUTION OF GAS METER		
	1	5	10
66	55	273	545
68	53	265	529
70	51	257	514
72	50	250	500
74	49	243	486
76	47	237	474
78	46	231	462
80	45	225	450
82	44	220	439
84	43	214	429
86	42	209	419
88	41	205	409
90	40	200	400
92	39	196	391
94	38	191	383
96	38	188	375
98	37	184	367
100	36	180	360
102	35	176	353
104	35	173	346
106	34	170	340
108	33	167	333
110	33	164	327
112	32	161	321
114	32	158	316
116	31	155	310
118	31	153	305
120	30	150	300

Table 6. Gas Flow Rates

CAPACITY OF BLACK IRON GAS PIPE (CU. FT. PER HOUR) FOR NATURAL GAS (SPECIFIC GRAVITY - 0.60)								
NOMINAL PIPE DIAMETER (IN.)	LENGTH OF PIPE RUN (FEET)							
	10	20	30	40	50	60	70	80
1/2	130	90	75	65	55	50	45	40
3/4	280	190	150	130	115	105	95	90
1	520	350	285	245	215	195	180	170
1 1/4	1,050	730	590	500	440	400	370	350
1 1/2	1,600	1,100	890	760	670	610		

Cubic Feet Per Hour Required = $\frac{\text{Input To Furnace (Btu/hr)}}{\text{Heating Value of Gas (Btu/Cu. Ft.)}}$

NOTE:

The cubic feet per hour listed in the table above must be greater than the cubic feet per hour of gas flow required by the furnace. To determine the cubic feet per hour of gas flow required by the furnace, divide the input rate of the furnace by the heating value (from gas supplier) of the gas.

Table 7. Gas Pipe Capacities

LOCAL HEATING VALUES FOR NATURAL GAS									
ALTITUDE ABOVE SEA LEVEL	BTU PER CUBIC FOOT								
	650	700	750	800	850	900	950	1,000	1,050
2,000 FT	LOW	LOW	LOW	LOW	LOW	LOW	HIGH	HIGH	HIGH
3,000 FT	LOW	LOW	LOW	LOW	LOW	LOW	HIGH	HIGH	HIGH
4,000 FT	LOW	LOW	LOW	LOW	LOW	HIGH	HIGH	HIGH	HIGH
4,999 FT	LOW	LOW	LOW	LOW	LOW	HIGH	HIGH	HIGH	HIGH

WARNING! The furnace is equipped to run on natural gas only. An LP/propane conversion kit is not available. Use of LP/Propane with this furnace can cause fire, explosion, property damage, carbon monoxide poisoning, personal injury, or death.

Table 8. Natural Gas Heating Values

NATURAL GAS W/ HIGH HEATING VALUE				
ALTITUDE ABOVE SEA LEVEL	INPUT (BTU)			
	55,000	70,000	100,000	
0 to 1,999 FT	3.4 mm	26	16	ORIFICE SIZE
	3.5	3.5	3.3	MANIFOLD PRESSURE
2,000 to 2,999 FT	3.4 mm			ORIFICE SIZE
	3.0			MANIFOLD PRESSURE
3,000 to 3,999 FT				ORIFICE SIZE
				MANIFOLD PRESSURE
4,000 to 4,999 FT				ORIFICE SIZE
				MANIFOLD PRESSURE

WARNING! The furnace is equipped to run on natural gas only. An LP/propane conversion kit is not available. Use of LP/Propane with this furnace can cause fire, explosion, property damage, carbon monoxide poisoning, personal injury, or death.

Table 9. High Altitude Deration Chart for Natural Gas - High Heating Value

NATURAL GAS W/ LOW HEATING VALUE				
ALTITUDE ABOVE SEA LEVEL	INPUT (BTU)			
	55,000	70,000	100,000	
0 to 1,999 FT	3.4mm	26	16	ORIFICE SIZE
	3.5	3.5	3.3	MANIFOLD PRESSURE
2,000 to 2,999 FT	3.4mm			ORIFICE SIZE
	3.0			MANIFOLD PRESSURE
3,000 to 3,999 FT				ORIFICE SIZE
				MANIFOLD PRESSURE
4,000 to 4,999 FT				ORIFICE SIZE
				MANIFOLD PRESSURE

WARNING! The furnace is equipped to run on natural gas only. An LP/propane conversion kit is not available. Use of LP/Propane with this furnace can cause fire, explosion, property damage, carbon monoxide poisoning, personal injury, or death.

Table 10. High Altitude Deration Chart for Natural Gas - Low Heating Value

INSTALLATION CHECKLIST

INSTALLER NAME:		
CITY:	STATE:	
INSTALLATION ADDRESS:		
CITY:	STATE:	
UNIT MODEL #		
UNIT SERIAL #		
Minimum clearances as shown in Figure 1, (page 5) ?	YES	NO
Has the owner's information been reviewed with the home-owner?	YES	NO
Has the literature package been left near the furnace?	YES	NO

REPLACEMENT PARTS

Replacement parts are available through your distributor. Please have the complete model and serial number of the unit when ordering replacement parts.

ELECTRICAL:

- Gas Valves
- Temperature Limit Switches
- Ignition Controls
- Thermostats
- Ignitors/Flame Sensors
- Transformers
- Pressure Switches

MOTORS:

- Blower Motor
- Inducer Blower Motor

COMPONENTS:

- Blower Assembly
- Gaskets
- Burners/Orifices
- Heat Exchanger
- Cabinet Panels

ATTENTION INSTALLERS:

It is your responsibility to know this product better than your customer. This includes being able to install the product according to strict safety guidelines and instructing the customer on how to operate and maintain the equipment for the life of the product. Safety should always be the deciding factor when installing this product and using common sense plays an important role as well. Pay attention to all safety warnings and any other special notes highlighted in the manual. Improper installation of the unit or failure to follow safety warnings could result in serious injury, death, or property damage.

These instructions are primarily intended to assist qualified individuals experienced in the proper installation of this appliance. Some local codes require licensed installation/service personnel for this type of equipment. Please read all instructions carefully before starting the installation. Return these instructions to the customer's package for future reference.

ELECTRICAL SYSTEM		
Electrical connections tight?	YES	NO
Line voltage polarity correct?	YES	NO
Supply Voltage (VOLTS):		
Has the thermostat been calibrated?	YES	NO
Is the thermostat level?	YES	NO
Is the heat anticipator setting correct?	YES	NO

GAS SYSTEM		
Gas Type: Natural Gas Only		
Gas pipe connections leak tested?	YES	NO
Gas Line Pressure (in - W.C.):		
Installation Altitude (FT.):		
Deration Percentage (%):		
Furnace Input (Btuh):		
Supply Air Temperature (° F):		
Return Air Temperature (° F):		
Temperature Rise (° F):		

COMBUSTION AIR & VENTING SYSTEM		
Is there adequate fresh air supply for combustion and ventilation?	YES	NO
Vent free from restrictions?	YES	NO
Filter(s) secured in place?	YES	NO
Filter(s) clean?	YES	NO
Flue connections tight?	YES	NO
Is there proper draft?	YES	NO

We Encourage Professionalism



Through Technician Certification by NATE



GAS-FIRED

