

## MODULAR AIR HANDLER

# INSTALLATION INSTRUCTIONS

**MB7VM SINGLE PHASE SERIES**

**MB7EM 3-PHASE SERIES**



## IMPORTANT

### ATTENTION INSTALLERS:

It is your responsibility to know this product better than your customer. This includes being able to install the product according to strict safety guidelines and instructing the customer on how to operate and maintain the equipment for the life of the product. Safety should always be the deciding factor when installing this product and using common sense plays an important role as well. Pay attention to all safety warnings and any other special notes highlighted in the manual. Improper installation of the furnace or failure to follow safety warnings could result in serious injury, death, or property damage.

These instructions are primarily intended to assist qualified individuals experienced in the proper installation of this appliance. Some local codes require licensed installation/service personnel for this type of equipment. Please read all instructions carefully before starting the installation. Return these instructions to the customer's package for future reference.

**DO NOT DESTROY. PLEASE READ CAREFULLY & KEEP IN A SAFE PLACE FOR FUTURE REFERENCE.**

## TABLE OF CONTENTS

<b>IMPORTANT SAFETY INFORMATION.....</b>	<b>3</b>	<b>STARTUP &amp; ADJUSTMENTS .....</b>	<b>9</b>
<b>GENERAL INFORMATION.....</b>	<b>3</b>	Before You Start the Air Handler .....	9
Requirements & Codes .....	3	Air Circulation Check .....	10
About the Air Handler.....	3	Running the Blower Continuously .....	10
Before You Install this Equipment.....	3	System Cooling .....	10
Minimum Clearances .....	4	System Heating .....	10
Locating the Air Handler .....	4	Turning the Blower Off .....	10
Operation of an Air Handler During Construction .....	4	Blower Configurations.....	10
Plenums & Air Ducts.....	4	Selecting Minimum Electric Heat Airflow.....	10
Supply Air Connections .....	4	Determining Nominal System Capacity.....	10
Return Air Connections .....	5	Selecting Basic Heating Airflow.....	10
Acoustical Duct Work .....	5	Selecting Basic Cooling / Heat Pump Airflow.....	10
Air Filters .....	5	<b>UNIT MAINTENANCE.....</b>	<b>11</b>
Unconditioned Spaces .....	5	<b>TROUBLESHOOTING .....</b>	<b>11</b>
Condensate Drainage .....	5	<b>FIGURES &amp; TABLES.....</b>	<b>12</b>
<b>AIR HANDLER INSTALLATION .....</b>	<b>5</b>	Figure 7. MB7 Physical Dimensions.....	12
Upflow Installation.....	5	Figure 8. MB7 Component Locations.....	13
Downflow Installation .....	6	Blower Performance Data.....	14
Horizontal Installation.....	6	Table 4. MB7EM Airflow Data .....	14
Horizontal Left Installations .....	7	Table 5. MB7EM (FSHE) Minimum Heating Airflow Settings (CFM) .....	14
Horizontal Right Installations.....	7	Table 6. Recommended Cooling Airflow Settings .....	14
<b>ELECTRICAL CONNECTIONS .....</b>	<b>8</b>	Table 7. MB7VM (VSHE) Airflow Data .....	15
Pre-Electrical Checklist.....	8	Electrical Data & Diagrams .....	16
Line Voltage .....	8	Table 8. MB7VM MCA & MOP Data .....	16
Thermostat Connections.....	8	Table 9. MB7(EM, VM) Heating Element Logic.....	17
Grounding .....	8	Figure 9. Typical Thermostat Connections.....	18
Control Board.....	8	Figure 10. Low Voltage Wiring For Twinning .....	19
Twinning.....	9	Figure 11. Two - Stage Control Board (MB7VM Models) .....	19
Line & Low Voltage Connections .....	9	Figure 12. Fixed Speed Motor Control Board (MB7EM Models) .....	20
Heater Kits .....	9	Figure 13. Variable Speed Motor Control Board (MB7VM Models) .....	20
Humidifier.....	9	Figure 14. MB7EM (460 V) Wiring Diagram.....	21
Dehumidification Options .....	9	Figure 15. MB7VM Wiring Diagram.....	22
Electronic Air Cleaner (EAC) .....	9	<b>INSTALLATION CHECKLIST.....</b>	<b>24</b>

## IMPORTANT SAFETY INFORMATION

Please read all information in this manual thoroughly and become familiar with the capabilities and use of this appliance before attempting to service or maintain this unit.

Safety markings are used frequently throughout this manual to designate a degree or level of seriousness and should not be ignored.

**WARNING** indicates a potentially hazardous situation that if not avoided, could result in personal injury or death.

**CAUTION** indicates a potentially hazardous situation that if not avoided, may result in minor or moderate injury or property damage.

---

### **WARNING:**

---

#### **ELECTRICAL SHOCK, FIRE OR EXPLOSION HAZARD**

**Failure to follow safety warnings exactly could result in serious injury or property damage.**

**Improper servicing could result in dangerous operation, serious injury, death or property damage.**

- **Before servicing, disconnect all electrical power to the indoor blower.**
  - **When servicing controls, label all wires prior to disconnecting. Reconnect wires correctly.**
  - **Verify proper operation after servicing.**
- 

### **WARNING:**

---

**The safety information listed in this manual must be followed during the installation, service, and operation of this unit. Unqualified individuals should not attempt to interpret these instructions or install this equipment. If you do not possess mechanical skills or tools, call your local dealer for assistance. Failure to follow safety recommendations could result in possible damage to the equipment, serious personal injury or death.**

---

- To minimize equipment failure or personal injury, it is essential that only qualified individuals install, service, or maintain this equipment. If you do not possess mechanical skills or tools, call your local dealer for assistance.
- Follow all precautions in the literature, on tags, and on labels provided with the equipment. Read and thoroughly understand the instructions provided with the equipment prior to performing the installation and operational checkout of the equipment.
- Use caution when handling this appliance or removing metal components. Personal injury can occur from sharp metal edges present in all sheet metal constructed equipment.
- Do not store any of the following on, or in contact with, the unit: Rags, brooms, vacuum cleaners, or other cleaning tools, spray or aerosol cans, soap powders, bleaches, waxes, cleaning compounds, plastics or plastic containers, paper bags or other

paper products, gasoline, kerosene, cigarette lighter fluid, dry cleaning fluids, paint thinners, or other volatile fluids.

- Installation of equipment may require brazing operations. Installer must comply with safety codes and wear appropriate safety equipment (safety glasses, work gloves, fire extinguisher, etc.) when performing brazing operations.
- Unless otherwise noted in these instructions, only factory authorized kits or accessories may be used with this product.
- The installer should become familiar with the units wiring diagram before making any electrical connections to the unit. See the unit wiring label or [Figure 14 \(page 21\)](#) & [Figure 15 \(page 22\)](#).
- Always reinstall the doors on the air handler after servicing or cleaning/changing the filters. Do not operate the air handler without all doors and covers in place.

## GENERAL INFORMATION

### Requirements & Codes

- The installer must comply with all local codes and regulations which govern the installation of this type of equipment. Local codes and regulations take precedence over any recommendations contained in these instructions. Consult local building codes for special installation requirements.
- All electrical wiring must be completed in accordance with local, state and national codes and regulations and with the National Electric Code (ANSI/NFPA 70) or in Canada the Canadian Electric Code Part 1 CSA C.22.1.
- Install this unit only in a location and position as specified on [page 4](#). This unit is designed only for Indoor installations and should be located with consideration of minimizing the length of the supply and return ducts. See [Table 4, \(page 14\)](#), [Table 5, \(page 14\)](#), [Table 6, \(page 14\)](#), & [Table 7, \(page 15\)](#) and the rating plate for proper circulating airflow data.
- This air handler may not be used for temporary heating or cooling of buildings or structures under construction. Operating the air handler during construction is not permitted and will void the manufacturer's warranty.

### About the Air Handler

This appliance has been tested for capacity and efficiency in accordance with AHRI Standards and will provide many years of safe and dependable comfort, providing it is properly installed and maintained. Abuse, improper use, and/or improper maintenance can shorten the life of the appliance and create unsafe hazards. Please read all instructions before installing the unit.

### Before You Install this Equipment

- ✓ This equipment is securely packaged at the time of shipment and upon arrival should be carefully inspected for damage prior to installing the equipment at the job site. Claims for damage (apparent or concealed) should be filed immediately with the carrier.
- ✓ it is recommended that the cooling load of the area to be conditioned should be calculated and a system of the proper capacity selected.
- ✓ Check the electrical supply and verify the power supply is adequate for unit operation. The system must be wired and provided with circuit protection in accordance with local building codes. If there is any question concerning the power supply, contact the local power company.
- ✓ Verify the duct system is appropriate for the air handler being installed. Please note that when replacing an existing system with lower air-flow, the duct system may require modification.

**Minimum Clearances**

- This appliance must be installed in accordance with clearances listed in [Table 1](#). The air handler must be installed with ample clearance for easy access to the air filter, blower assembly, heater assembly, controls, and vent connections.
- Static pressure drop through louvered openings and through return air plenums should be considered in the overall duct design in the determination of the total external static pressure.

**Locating the Air Handler**

- Survey the job site to determine the best location for mounting the unit. Consideration should be given to availability of electric power, service access, and noise.
- The dimensions of the room or alcove must be able to accommodate the overall size of the unit and the installation clearances listed in [Table 1](#). Physical dimensions for this air handler are shown in [Figure 7 \(page 12\)](#).
- The air handler should be set into position before routing the refrigerant tubing.

**Operation of an Air Handler During Construction**

**⚠ CAUTION:**

**Failure to follow these instructions will void the factory warranty and may significantly reduce the life or the performance of the air handler, and/or result in other unsafe conditions. It is the responsibility of the installing contractor to insure these provisions are met.**

Operating an air handler in a construction environment is prohibited and will void the warranty. Proper use of commercial portable space heating equipment during construction is recommended.

**Plenums & Air Ducts**

- Plenums and air ducts should be installed in accordance with the standards of the National Fire Protection Association Standard for Installation of Air Conditioning Systems (NFPA 90A), Standard for Installation of Residence Type Warm Air Heating and Air Conditioning Systems (NFPA

90B), and all applicable local codes. NFPA publications are available by writing to: National Fire Protection Association, Batterymarch Park, Quincy, ME 02269 or visit [www.NFPA.org](http://www.NFPA.org) online.

**⚠ WARNING:**

**All return ducts must be secured to the air handler using appropriate methods. All return ducts must be adequately sealed. When return air is provided through the bottom of the unit, the joint between the air handler and the return air plenum must be air tight.**

**Return air and circulating air ducts must not be connected to any other heat producing device such as a fireplace insert, stove, etc. This may result in fire, explosion, carbon monoxide poisoning, personal injury, or property damage.**

- Design the duct work according to methods described by the Air Conditioning Contractors of America (ACCA).
- This unit is designed only for use with a return and supply duct. The return air duct must have the same free area as the opening provided on the air handler. The ducts should be appropriately sized to the capacity of the air handler to ensure its proper airflow rating.
- This unit should be located with consideration of minimizing the length of the supply and return ducts. See [Table 4, \(page 14\)](#), [Table 5, \(page 14\)](#), [Table 6, \(page 14\)](#), & [Table 7, \(page 15\)](#) and the rating plate for proper circulating airflow data.
- Whenever the supply or return air ducts pass through the floor, a 1/4" thick noncombustible resilient gasket must be used between the duct, unit and floor
- Use transition fittings if the supply and/or return air openings of the unit do not match the duct openings. These transitions should be dimensioned in accordance with standard practice as specified in the ASHRAE recommendations for duct transitions.
- The supply air ductwork must be of noncombustible material for the first 24 inches from the unit. Some installations with a short, straight run from the unit to the first branch takeoff may require acoustical lining inside the supply air ductwork. Consult with local codes for requirements specific to your area.
- Flexible connectors may be used between the unit and the ductwork to prevent transmission of vibration from the unit to the structure. If electric heater kits are installed, heat resistant material must be used for the flexible connector at the supply air end of the unit.
- It is good practice to seal all connections and joints with industrial grade sealing tape or liquid sealant. Requirements for sealing ducts vary from region to region. Consult with local codes for requirements specific to your area.

INSTALLATION CLEARANCES	
Left Side ..... 0 Inches	Right Side ..... 0 Inches
Back..... 0 Inches	Front ..... †See Notes

**†NOTE:**  
Closet or Alcove Installations - Allow 24 in. minimum clearance from front of unit to nearest wall or partition for servicing. Recommended clearance is 36 in.

**Table 1. Minimum Unit Clearances**

**Supply Air Connections**

The supply air must be delivered to the heated space by duct(s) secured to the blower's casing, running full size and without interruption. Tape or seal all seams if required by local code.

*Upflow & Horizontal Applications:* To attach the supply air duct, bend the flanges (on top of the unit) outward 90° with a pair of wide duct pliers. Position the duct on top of the blower and secure together with sheet metal screws.

*Downflow Applications:* Position the blower over the duct and secure together with sheet metal screws.

### Return Air Connections

The return air must be delivered to the blower by duct(s) secured to the casing, running full size and without interruption. Tape or seal all seams if required by local code.

*Upflow & Horizontal Applications:* Position the blower over the duct and secure together with sheet metal screws.

*Downflow Applications:* To attach the supply air duct, bend the furnace flanges outward 90° with a pair of wide duct pliers. Position the duct on top of the cased coil and secure together with sheet metal screws.

### Acoustical Duct Work

- Certain installations may require the use of acoustical lining inside the supply duct work. Acoustical insulation must be in accordance with the current revision of the Sheet Metal and Air Conditioning Contractors National Association (SMACNA) application standard for duct liners. Duct lining must be UL classified batts or blankets with a fire hazard classification of FHC-25/50 or less.
- Fiber duct work may be used in place of internal duct liners if the fiber duct work is in accordance with the current revision of the SMACNA construction standard on fibrous glass ducts. Fibrous duct work and internal acoustical lining must be NFPA Class 1 air ducts when tested per UL Standard 181 for Class 1 ducts.
- Damping ducts, flexible vibration isolators, or pleated media-style filters on the return air inlet of the air handler may be used to reduce the transmission of equipment noise emanating from the air handler. These treatments can produce a quieter installation, particularly in the heated space. However, they can increase the pressure drop in the duct system. Care must be taken to maintain the proper maximum pressure rise across the air handler, temperature rise and flow rate. This may mean increasing the duct size and/or reducing the blower speed. These treatments must be constructed and installed in accordance with NFPA and SMACNA construction standards. Consult with local codes for special requirements. For best sound performance, be sure to install all the needed gaskets and grommets around penetrations into the air handler, such as for electrical wiring.

### Air Filters

---

## **WARNING:**

---

**Never operate the air handler without a filter or with doors removed. Dust and lint can build up on internal components, resulting in loss of efficiency, equipment damage, and possible fire.**

MB7 Series air handlers are not equipped with a filter rack; however, it is strongly recommended that a filter be located in the return air duct system. Installing the filter and replacing it every 3 months will increase air quality throughout the home.

### Unconditioned Spaces

All duct work passing through unconditioned space must be properly insulated to minimize duct losses and prevent condensation. Use insulation with an outer vapor barrier. Consult your Distributor for the recommended type and thickness of insulation for your area as required by local codes.

## Condensate Drainage

---

### **CAUTION:**

---

**The air handler must be level to ensure proper condensate drainage. An unlevel installation may result in structural damage, premature equipment failure, or possible personal injury.**

---

- To ensure proper condensate drainage, the unit must be installed in a level position within 1/4 inch over the height, width, and depth of the unit. The best system performance will be obtained if the unit is located in a centralized position with respect to the air distribution system. Refer to the Installation Instructions supplied with the Cased Coil for proper condensate drain connections.
- If the air handler is located in or above a living space where damage may result from condensate overflow, an auxiliary drain pan should be installed under the unit. A separate drain line should extend from the pan to a conspicuous point and serve as an alarm indicating that the primary drain is restricted. As an alternative to a separate drain line, an approved water level indicator or float switch device should be used to shut down the unit in the event water is detected in the auxiliary pan.
- During system checkout, inspect the drain line and connections to verify proper condensate drainage.
- Methods for disposing of condensate vary according to local codes. Refer to local codes or authority having jurisdiction for restrictions and proper condensate disposal requirements.

## AIR HANDLER INSTALLATION

The MB7 Series air handler is shipped ready for vertical upflow installation and is approved for attic, basement, alcove/closet or crawlspace installation with zero clearance to combustibles. They may also be applied in downflow or horizontal left and right discharge applications. See [Table 1, \(page 4\)](#) for required installation clearances. **This appliance is approved only for indoor use.**

**NOTE:** For shipping purposes, the front and rear joining brackets are located in the unit's heater box. Remove these two items from the heater box before beginning.

- The unit must be leveled at installation and attached to a properly installed duct system.
- The surface that the air handler is mounted on must provide sound physical support of the unit.
- The air handler must be installed so that all electrical components are protected from water.
- If a louvered door is installed across the front of this unit, the appliance must be mounted flush or behind front edge of finished wall.
- Modular air handlers are intended to be mated with specific C6 & C7 cased coils. Reference the Technical Specifications for coil mating combinations.

### **Upflow Installation**

MB7 series air handlers are shipped from the factory ready for upflow configuration as shown in [Figure 1 \(page 6\)](#). Return air must enter from the bottom of the unit.

1. Remove the bracket above the door of the cased coil. Retain the screws for later use. **NOTE:** Before mating the modular unit with the cased coil, clean the mating surfaces on both

units and apply the black neoprene gasket tape to the top of the coil case (except the rear surface). Make sure there are no gaps on the front and side flanges.

- Carefully place the modular air handler on top of the cased coil making sure not to damage the cased coil flanges. The units will be flush in front with an overhang in the back as shown in [Figure 2](#).
- Remove the lower front bracket from the modular unit. Retain the screws for later use.
- Attach the front joining bracket to the front of the modular unit. Align the screw holes in the bracket with the holes from the lower front bracket and the top panel of the coil case. See [Figure 3](#).
- Secure the bracket with the screws removed earlier in steps 1 & 3.
- Attach the rear joining bracket to the backside of the modular unit and cased coil. Position the bracket so that it is flush with the sides and back of the units with the 1/2" insulation facing the rear gap between the units.
- Secure the rear bracket with self tapping screws.

### Downflow Installation

The MB7 Series Modular air handler may be installed in a downflow configuration as shown in [Figure 1](#). Return air must enter through the top of the unit.

- Remove the lower front bracket ([Figure 3](#)) from the modular unit. Retain the screws for later use.
- Remove the door from the cased coil and the screws (on the side of the cased coil) securing the lower tie bar in place. Retain the screws for later use. **NOTE:** Before mating the modular unit with the cased coil, clean the mating surfaces on both units.
- Flip the modular unit upside down and apply the black neoprene gasket tape to the top of the air handler. **NOTE:** The blowers flanged surface is now beneath the air handler and will connect with the supply air duct.
- Carefully place the cased coil on top of the modular air handler. **NOTE:** Make sure the units are flush in the front and on the sides with a "step" fit in the back and that there are no gaps on the sides. See [Figure 4 \(page 7\)](#).
- Attach the front joining bracket to the cased coil and the air handler. Align the screw holes in the bracket with the holes where the lower front bracket and lower tie bar were attached.
- Secure the bracket to the modular unit and the cased coil with the screws removed earlier in steps 1 & 2.
- Attach the rear joining bracket to the backside of the modular unit. Position the bracket so that it is flush with the sides and back of the units with the 1/2" insulation facing the rear gap between the units.
- Secure the rear bracket to the modular unit and cased coil with self-tapping screws.

### Horizontal Installation

MB7 air handlers are shipped from the factory ready for horizontal left applications and horizontal right applications. The blowers can be installed horizontally in an attic, basement, crawl space or alcove. They can also be suspended from a ceiling in a basement or utility room in either a right to left airflow or left to right airflow. A typical installation of the unit in a suspended horizontal application is shown in [Figure 5 \(page 7\)](#).

When mating the blower and coil for horizontal left or right applications, reference the upflow instructions on [page 5](#). Make sure to account for the coil orientation by configuring the coil drain pan assembly properly. Multi-position procedures are also available in the cased coil Installation Instructions supplied with the unit.

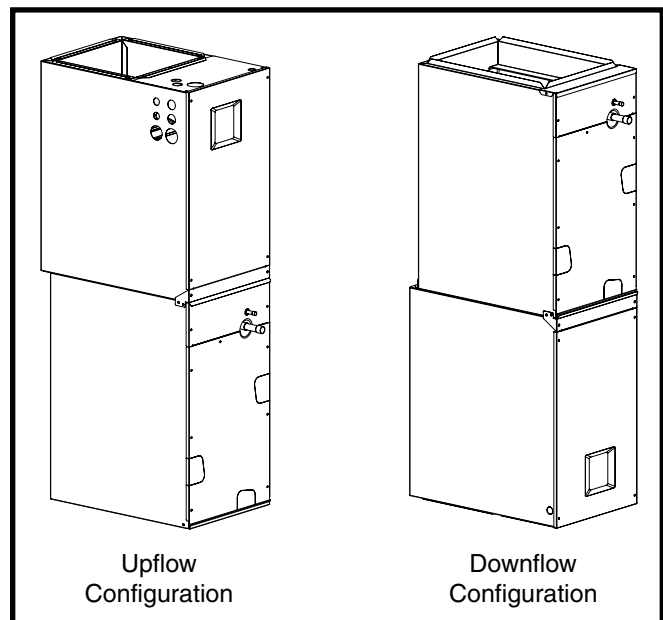

**Figure 1. Upflow & Downflow Installation**

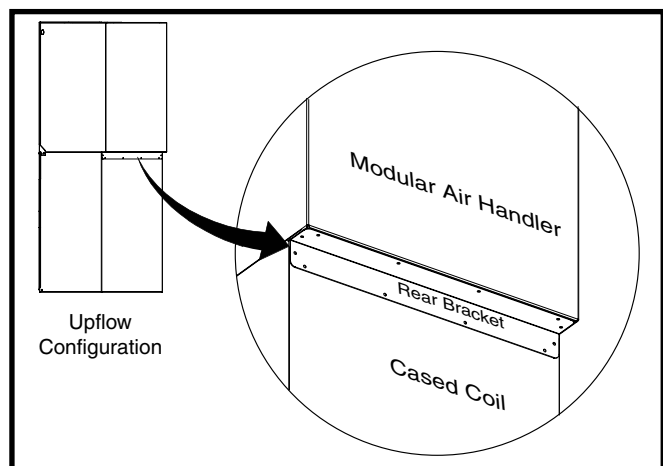

**Figure 2. Rear Bracket Installation - (Upflow Only)**

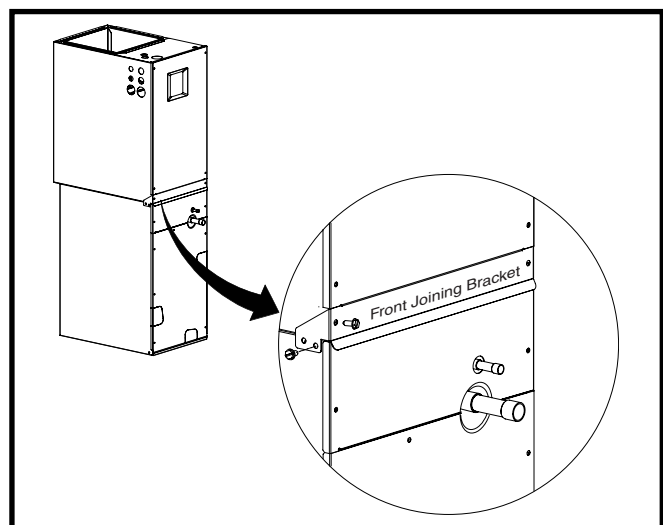

**Figure 3. Front Bracket Installation - (Upflow Only)**

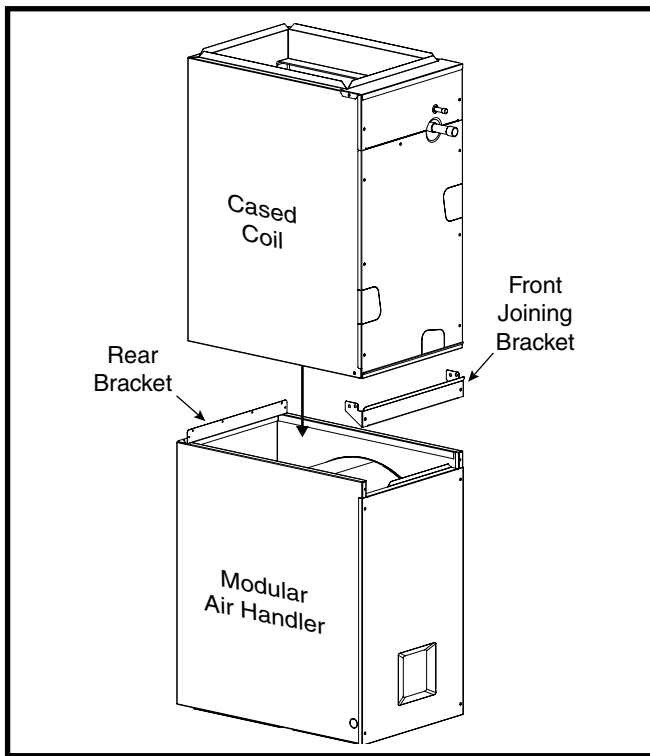

**Figure 4. Downflow Brackets**

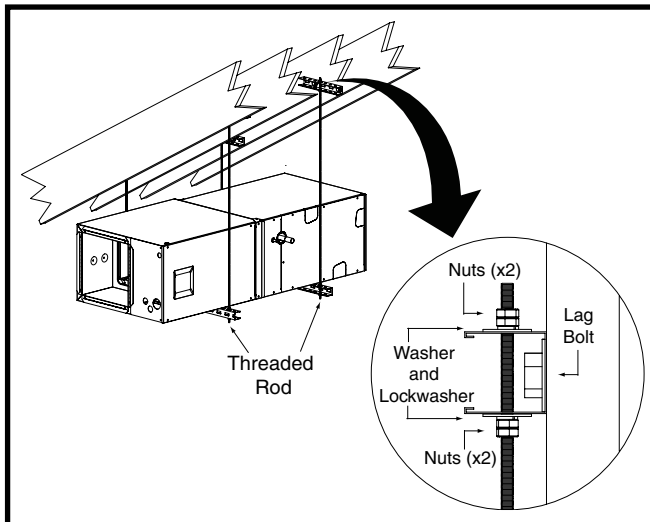

**Figure 5. Unit Horizontally Suspended**

**NOTES:**

- In many applications when joined with a cased coil, the shorter horizontal drain pan extension which is included with the MB7 must be used. This is to avoid any interference with the extension included with the cased coil.
- The air handler may or may not be shipped from the factory with all the parts required for horizontal left applications and horizontal right applications. If your unit does not have parts for a horizontal application, a kit may be available.
- In horizontal right applications where the air handler is in a humid location in an unconditioned space, it is recommended to install a condensate shield kit over the control board.

If suspending the air handler from the ceiling, assemble a support frame (Figure 5) using slotted iron channel and full threaded rod. Fasten the frame together with nuts, washers, and lockwashers. Secure the support frame to the rafters with lag bolts. The air handler can also be suspended using steel straps around each end of the unit. The straps should be attached to the air handler with sheet metal screws and to the rafters with bolts.

**Horizontal Left Installations**

1. Remove the coil access door.
2. Remove the plug from one of the threaded holes in the horizontal drain pan. Completely remove the webbing in the threaded holes of the horizontal drain pan. **If the webbing is not removed, the condensate will not drain properly and ceiling damage may occur.**
3. Insert the plug (from horizontal drain pan) into the open and unused drain hole in the drain pan at the bottom of the unit to block bypass air.
4. Remove the corresponding drain line knockout from the coil access door to allow access to the horizontal drain.
5. Replace the door and attach the drain line.

**Horizontal Right Installations**

1. Remove the coil access door. Unscrew the line-set tube close-off plate from the front left cabinet rail.
2. Slide the coil and drain pan assembly out of the unit.
3. Remove the sheet metal hairpin covers (if supplied) from the back of the coil and discard.
4. Place the horizontal drain pan on the opposite side of the coil. On units with 2 sets of knockouts, remove the other set of knockouts in the coil spacing plates and insert support rod.
5. Slide the coil and the horizontal drain pan assembly back into the unit. Re-attach the tube close off plate.

**NOTE:** For A-size cabinet applications, it may be preferable to remove the blower assembly prior to installing the coil & drainpan. In this case follow instructions 1-4 as listed above but also remove the blower access door and blower assembly. The blower assembly is secured with two screws on either side near the front. With these removed the blower assembly can slide out of the front of the unit. Install the coil and drain pan as described in step 5 and then replace the blower assembly. Take care to ensure that the flanges on the sides of the blower assembly are captured by the pockets in the blower deck. It may be necessary to lift the blower assembly during insertion to allow the lower blower leg to clear the side of the drain pan. The blower will stop against the back of the blower deck. Replace the two screws and the blower access door and proceed with steps 6-9.

6. Remove the plug from one of the threaded holes in the horizontal drain pan. Completely remove the webbing located in the threaded holes of the drain pan. **IMPORTANT:** If the webbing is not removed, the condensate will not drain properly and ceiling damage may occur.
7. Insert the plug (from horizontal drain pan) into the open and unused drain hole in the drain pan at the bottom of the unit to block bypass air.
8. Remove the corresponding drain line knockout from the coil access door to allow access to the horizontal drain.
9. Replace the door and attach the drain line.

## ELECTRICAL CONNECTIONS

---

### **WARNING:**

---

#### **ELECTRICAL SHOCK, FIRE OR EXPLOSION HAZARD**

**Failure to follow safety warnings exactly could result in serious injury or property damage.**

**Improper servicing could result in dangerous operation, serious injury, death or property damage.**

- **Before servicing, disconnect all electrical power to the indoor blower.**
- **When servicing controls, label all wires prior to disconnecting. Reconnect wires correctly.**
- **Verify proper operation after servicing.**

- Electrical connections must be in compliance with all applicable local codes and ordinances, and with the current revision of the National Electric Code (ANSI/NFPA 70).
- For Canadian installations, the electrical connections and grounding shall comply with the current Canadian Electrical Code (CSA C22.1 and/or local codes).

#### **Pre-Electrical Checklist**

- ✓ Verify the voltage, frequency, and phase of the supply source match the specifications on the unit rating plate.
- ✓ Verify that the service provided by the utility is sufficient to handle the additional load imposed by this equipment. See the unit wiring label or [Table 8, \(page 16\)](#) for proper MCA & MOP information.
- ✓ Verify factory wiring is in accordance with the unit wiring diagram. See [Figure 14 \(page 21\)](#) & [Figure 15 \(page 22\)](#). Verify none of the connections loosened during shipping or installation.

#### **Line Voltage**

- **An electrical disconnect must be located within sight of and readily accessible to the unit.** This switch shall be capable of electrically de-energizing the outdoor unit. See unit data label for proper incoming field wiring. Any other wiring methods must be acceptable to authority having jurisdiction.
- It is recommended that the line voltage to the unit be supplied from a dedicated branch circuit containing the correct fuse or circuit breaker for the unit.
- Overcurrent protection must be provided at the branch circuit distribution panel and sized as shown on the unit rating label and according to applicable local codes. See the unit rating plate and [Table 8, \(page 16\)](#) for maximum circuit ampacity and maximum overcurrent protection limits.
- The installer should become familiar with the wiring diagram/schematic before making any electrical connections to the unit. See the unit wiring label or [Figure 14](#) & [Figure 15](#).
- Use only copper wire for the line voltage power supply to this unit. Use proper code agency listed conduit and a conduit connector for connecting the supply wires to the unit. Aluminum supply wire may be used if a heater kit is installed.
- If replacing any of the original wires supplied with the unit, the replacement wire must be copper wire consisting of the same gauge and temperature rating.
- Provide power supply for the unit in accordance with the unit wiring diagram, and the unit rating plate. Use UL listed conduit and conduit connectors for connecting the supply wires to the

unit and for proper grounding. Field supplied bushings for the power supply cables must be added to support and protect the power supply cables.

- All 208/230 Volt units are shipped from the factory wired for 240 volt operation. For 208V operation, remove the lead from the transformer terminal marked 240V and connect it to the terminal marked 208V.

#### **Thermostat Connections**

- Thermostat connections shall be in accordance with the instructions supplied with the thermostat. The thermostat used with this equipment must operate in conjunction with any installed accessories. Typical AC and air handler hookups are shown in [Figure 9 \(page 18\)](#).

---

### **CAUTION:**

---

**Isolation must be maintained from the external Class 2 output of any transformer in a cooling circuit. Use a thermostat with isolating contacts to prevent inter-connection of Class 2 outputs.**

- Where local codes require that the thermostat wiring must be routed through a conduit or raceway, splices can be made inside the unit; however, all wiring must be NEC Class 1 and must be separated from incoming power leads.
- The thermostat should be mounted about 5 feet above the floor on an inside wall. DO NOT install the thermostat on an outside wall or any other location where its operation may be adversely affected by radiant heat from fireplaces, sunlight, or lighting fixtures, and convective heat from warm air registers or electrical appliances. Refer to the thermostat manufacturer's instruction sheet for detailed mounting and installation information.
- Install the grommet, which is packed with the unit, in the hole for low-voltage wires. Properly connect the low-voltage wiring between the thermostat, outdoor unit, and control board. **NOTE:** When the low voltage wires are positioned in this grommet, the grommet will prevent chafing and/or shorting of the low voltage leads

**Important!** On variable speed models when the unit is used in an air conditioning system, connect the **O** terminal to the **Y** terminal. See [Figure 9 \(page 18\)](#).

#### **Grounding**

---

### **WARNING:**

---

**The unit cabinet must have an uninterrupted or unbroken electrical ground to minimize personal injury if an electrical fault should occur. Do not use gas piping as an electrical ground!**

This unit must be electrically grounded in accordance with local codes or, in the absence of local codes, with the National Electrical Code (ANSI/NFPA 70) or the CSA C22.1 Electrical Code. Use the grounding lug provided in the control box for grounding the unit.

#### **Control Board**

The control board in the air handler controls the timing sequence of the elements. Depending on the thermostat connection, there are multiple timing sequence variations that can be chosen. The board also is equipped with a 3 second blower on delay, a 15 second blower off delay in electric heat mode and a 40 second

blower off delay in cooling. See [Figure 11 \(page 19\)](#), [Figure 12 \(page 20\)](#), & [Figure 13 \(page 20\)](#) for control board layout and [Table 9, \(page 17\)](#) for element sequences.

**Twinning**

These instructions are to be used when connecting two MB7EM air handlers (2-5 ton models) to a common single stage A/C condensing unit or heat pump. Twinning is possible for MB7EM units with fixed speed (FSHE) motors. Twinning is not possible for units with variable (VSHE) speed motors. All low voltage wiring instructions, cautions, and warnings accompanying the air handler remain applicable, except for:

**IMPORTANT NOTES:**

- If there is any other air moving device in the duct work, consult the factory for a resolution.
- Variable speed air handlers cannot be twinned. Please follow the instructions supplied with the kit.

**Line & Low Voltage Connections**

- The line voltage connections for both air handlers must be the same phase and on the same leg of power.
- When matched with an S6BQ series AC outdoor unit, both air handler’s 24V transformers must be removed from the control circuit by removing and discarding the RED wire located on the transformer’s secondary. These outdoor units come standard with 24V power supply sufficient for powering both air handlers.
- Low voltage wiring should be connected as shown in [Figure 10 \(page 19\)](#).
- Wire all other low voltage thermostat terminals to both air handlers as shown in [Figure 9 \(page 18\)](#).

**Heater Kits**

Field-installed electric heater kits are available. Instructions for installing the electric heaters are included with the heaters. Additional heater kit information can be found in the units Technical Specifications.

Air handlers set up with 15 kw or more of electric heat will normally be configured for multiple-circuit power supply. They may, however, be connected to a single-circuit power supply with the addition of a single circuit accessory kit. Select the wire size and over-current protection in accordance with the minimum circuit ampacity and maximum over-current protection shown in [Table 8, \(page 16\)](#). See also the units Technical Specifications.

When electric heat packages with circuit breakers are field-installed, the circuit breaker may be used as a disconnecting means in most applications. Reference the NEC and local codes for disconnect requirements.

If a heater kit is installed:

The MB7 air handler is shipped from the factory without an electric heater kit installed. If Electric heat is desired, the H8HK heater kit may be purchased separately and field installed. Determine the correct size heater kit for your unit by referring to the list below or the units rating label.

- A Size Cabinet (1200 CFM)..... 15Kw max
- B Size Cabinet..... 20Kw max
- C Size Cabinet..... 20Kw max

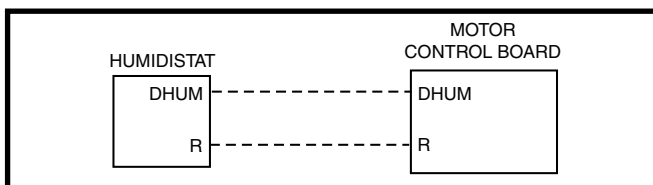

**Figure 6. DHUM Wiring Configuration**

1. Connect the 2 wire plug of the air handler to the mating 2 wire plug of the heater kit.
2. Connect the line voltage leads to the circuit breaker or terminal block provided.
3. Connect the heater kit plug with the mating receptacle on the air handler control board.

If a heater kit is not installed:

1. Remove the 2 wire plug of the air handler by cutting the wires and discarding the plug.
2. Strip the ends of the 2 air handler wires and connect to the line-voltage leads with the 2 wire nuts provided.

**Humidifier**

The unit has an output to power a humidifier when the blower is running. This output is rated to 1.0 amp at 208/240V. Connection is made to the **HUM** terminal on the control board. See [Figure 11 \(page 19\)](#).

**Dehumidification Options**

The motor control boards ([Figure 12](#) & [Figure 13](#)) have a **DHUM** connection that allows the system to increase the amount of humidity that is removed from the circulating air. This is accomplished by reducing the CFM and allowing the cooling coil to become colder. This will only occur when there is a call for cooling. There are many ways that this can be electrically wired.

1. If the room thermostat incorporates a humidity sensor and **DHUM** output, connect the **DHUM** on the thermostat to the **D** terminal on the motor control board. See [Figure 6 \(page 9\)](#).
2. If using a separate humidistat, connect the **DHUM & R** terminals on the humidistat to the **D & R** terminals on the motor control board of the air handler. In this option, the **DHUM** output of the humidistat must be set so it is only closed when there is a call for dehumidification.
3. If a humidistat is not available, it is an acceptable option to connect the **R & D** terminals on the motor control board together with a field supplied wire. This option causes the blower to run at a reduced CFM for 10 minutes after a call for cooling. **NOTE:** If outdoor unit is a heat pump, connect the **O** terminal to the **D** terminal.

**Electronic Air Cleaner (EAC)**

The unit has an output to power an electronic air cleaner when the blower is running. This output is rated to 1.0 amp at 208/240V. See [Figure 11 \(page 19\)](#).

**STARTUP & ADJUSTMENTS**

**Before You Start the Air Handler**

Prior to start-up, complete the following inspections:

- ✓ Verify the unit is level and properly located with adequate clearances for servicing the unit. See [Table 1, \(page 4\)](#).
- ✓ Check condensate drain line(s) for proper drainage.
- ✓ Verify the surrounding area and top of the unit is free from obstructions and debris.
- ✓ Check all duct connections. Make sure the duct work is adequately sealed to prevent air leakage.
- ✓ Check all coil connections for leaks.
- ✓ Verify that the line voltage power leads are securely connected and the unit is properly grounded. Make sure all doors are installed before restoring power to the unit
- ✓ Verify the thermostat is wired correctly. Make sure all low voltage wires are securely connected.
- ✓ Verify the power supply branch circuit overcurrent protection is sized properly.
- ✓ Verify filter is properly and securely installed.

## Air Circulation Check

### Running the Blower Continuously

Set the thermostat's system mode to **OFF** and the thermostat's fan mode to **ON**. The blower motor should run continuously. Check for air delivery at the register(s). Make sure that there are no obstructions at the registers or in the ducts.

### System Cooling

1. Set the thermostat's system mode to **COOL** and fan mode to **AUTO**. Lower the thermostat's temperature mode below room temperature and observe that the blower energizes. Check the air being discharged at the register is cooler than room temperature. Verify unit refrigerant pressures are in order. Blower should be turning in direction indicated by arrow.

**NOTE:** DO NOT alter unit wiring. Listen for any unusual noises. Locate the source and correct as needed.

2. Allow the unit to run for several minutes and then set the thermostat's temperature above room temperature. Verify the blower cycles off with the thermostat.

### System Heating

1. Set the thermostat's system mode to **HEAT** and the fan mode to **AUTO**. Increase the thermostat's temperature above room temperature and observe that the blower energizes. Check the air being discharged at the register is warmer than room temperature.

2. Allow the unit to run for several minutes and then set the thermostat's temperature below room temperature. Verify the blower cycles off with the thermostat.

### Turning the Blower Off

Set thermostat's fan mode to **AUTO**, the blower will shut down immediately.

## Blower Configurations

### Selecting Minimum Electric Heat Airflow

The minimum electric heat airflow setting controls the minimum air flow that will be produced whenever electric heater kits are used. When the electric heater kit is energized along with a heat pump, the airflow may be higher depending on the basic cooling/heat-pump airflow setting. The minimum electric heat airflow is selected by the red blower wire on 3-speed models or setting switches 1,2,3 & 4 on MB7EM models. MB7VM models automatically set the heating speed based on the amount of installed heat. The A/B switch must be set appropriately for the unit cabinet size. For C-sized cabinets, the A/B switch can be set in either position. The remaining 3 HEAT switches have no function. Switch settings are listed in [Table 4, \(page 14\)](#) & [Table 7, \(page 15\)](#). **NOTE:** For MB7EM Models, the minimum electric heat airflow setting may be set higher, but must never be set lower than the setting shown in [Table 6](#).

### Determining Nominal System Capacity

To select the appropriate airflows for the air handler, the nominal system capacity must be known. The nominal system capacity is always the nominal capacity of the outdoor unit. However, in some situations the nominal system capacity may not be the same as the nominal capacity of the air handler. Always refer to the nominal capacity of the outdoor unit to determine the nominal system capacity.

**NOTE:** The CFM values listed in [Table 7](#) are not dependent on duct static pressure. The VSHE motor automatically compensates for changes in duct static pressure (within the limits of the motor).

**IMPORTANT!** This air handler has been designed to give the installer maximum flexibility to optimize system performance, efficiency, and comfort. Because there are so many different

ways to set up the air handler it is important to read and follow these directions carefully.

MB7EM & MB7VM air handlers use high efficiency circulating air motors that come in two variations and both are controlled differently. The fixed speed motor control board ([Figure 12 \(page 20\)](#)) controls the torque and the variable speed motor control board ([Figure 13 \(page 20\)](#)) controls the airflow at a constant CFM.

Before operation, the air handler must be configured to match the unit with the system, system options, and climatic conditions. During normal operation, the motor will gradually change speeds during start-up, shut down, when thermostat inputs change, and when the duct static pressure changes (vents closed or opened, filter clogging, etc.). The air handler is configured by setting the selector switches and removing jumper connectors.

### Selecting Basic Heating Airflow

Fixed & variable speed motor control boards ([Figure 12](#) & [Figure 13](#)) contain a set of dip switches for setting the blower speed. For MB7EM models, pins 1-4 set the speed for heating. For MB7VM models, the A/B switch must be set for the appropriate cabinet size (either setting can be used for C-size cabinets). The airflow is set automatically based on the amount of installed heat. The cooling speed is selected via switches 5, 6, 7, & 8. To determine the appropriate switch settings for your installation, see [Table 4](#), [Table 5](#), [Table 6](#), & [Table 7](#).

### Selecting Basic Cooling / Heat Pump Airflow

The basic cooling/heat-pump airflow is controlled by setting switches 5 - 8 on the motor control board (mounted on the blower). All airflows for other modes of operation (except electric heat) are determined by this basic setting. FAN ONLY would deliver 50% of the selected cooling airflow. [Table 6](#) lists the basic airflow values recommended for each nominal system capacity. To determine dip switch settings, refer to [Table 4, \(page 14\)](#) for FSHE applications and [Table 7, \(page 15\)](#) for VSHE applications.

- When operating in the heat pump mode, a higher basic airflow setting will increase the energy efficiency and capacity but will also decrease the supply air temperature.
- For maximum capacity and energy efficiency, select an airflow at or near the top of the range for that nominal capacity. See [Table 6](#).
- For maximum dehumidification, select an airflow near the middle or bottom of the range for that nominal capacity. Additional information on humidity control can be found in the Humidistat and Delay Setting sections.
- For thermostats with a dehumidifier output, use a field supplied wire to connect the thermostat's dehumidifier output to the terminal marked **DHUM**. The thermostat should be set so that the **DHUM** output should be high (energized) when dehumidification is needed. See also Dehumidification Options section.

**IMPORTANT!** If coil icing is observed, the basic cooling/heat-pump airflow selected may be too low. Verify the setting selected is within the range shown in [Table 6](#) and that the the system is properly charged. Please refer to the instructions supplied with the outdoor unit. If icing continues to occur, raise the selected airflow one or two steps.

**NOTE:** Variable speed air handlers with SEER ratings higher than 15 are matched with a 2-stage cooling outdoor unit. They are programmed to operate at 75% of the selected airflow while the system is in the lo-cool mode and 100% of the selected airflow while in hi-cool mode.

## UNIT MAINTENANCE

Proper maintenance is most important to achieve the best performance from an air handler. Some of the components and their locations are shown in [Figure 8 \(page 13\)](#). If any component of the air handler must be replaced, use only factory authorized replacement parts specified in the Replacement Parts List provided online.

### **WARNING:**

#### **ELECTRICAL SHOCK, FIRE OR EXPLOSION HAZARD**

**Failure to follow safety warnings exactly could result in serious injury or property damage.**

**Improper servicing could result in dangerous operation, serious injury, death or property damage.**

- **Before servicing, disconnect all electrical power to the indoor blower.**
- **When servicing controls, label all wires prior to disconnecting. Reconnect wires correctly.**
- **Verify proper operation after servicing.**

- These maintenance instructions are primarily intended to assist qualified technicians experienced in the proper maintenance and operation of this appliance.
- Always reinstall the doors on the air handler after servicing or cleaning/changing the filters. Do not operate the air handler without all doors and covers in place.
- To achieve the best performance and minimize equipment failure, it is recommended that a yearly maintenance checkup be performed. At a minimum, this check should include the following items:

**Air Filter(s)** - Inspect and replace the air filter at the beginning of heating and cooling season. It is recommended that the filter be cleaned or replaced every 4 to 6 months at a minimum. Newly built or recently renovated homes may require more frequent changing until the construction dust has minimized.

### **WARNING:**

**Never operate the air handler without a filter in place. Dust and lint in the return air can build up on internal components, resulting in loss of efficiency, equipment damage, and possible fire.**

Filters designed to remove smaller particles such as pollen, may require additional maintenance.

**Blower Compartment** - Dirt and lint can create excessive loads on the motor resulting in higher than normal operating temperatures and shortened service life. It is recommended that the blower compartment be cleaned of dirt or lint that may have accumulated in the compartment or on the blower and motor as part of the annual inspection.

**Blower Fan Wheel** - Inspect the blower wheel blades for accumulations of dirt and clean if necessary. Inspect mounting nut for tightness.

**Blower Motor & Assembly** - Inspect the blower assembly and motor mounting brackets for tightness and corrosion. Correct deficiencies if necessary. The blower motor contains sealed bearings and under normal operating conditions, no maintenance is necessary for the life of the equipment.

**Cooling Coil** - Inspect the cooling coil, drain pan, and condensate drain at the beginning of each cooling season for cleanliness. Clean these components as necessary using a mild detergent and water. After cleaning, flush the coil, drain pan, and condensate drain to remove all detergent.

**IMPORTANT:** Use caution when cleaning these components so that the insulation does not get wet.

## TROUBLESHOOTING

If the air handler fails to operate, check the following:

- Is the electric turned on?
- Is the thermostat operating properly?
- Are the blower compartment door(s) in place?
- Is the air handler disconnect closed?
- Has the circuit breaker tripped or the control board fuse burned open?
- Are any manual reset switches open?
- Is the filter dirty or plugged?
- Is the LED on both control boards constantly ON? If not, refer to [Table 2](#) or [Table 3](#) to determine fault condition.

RED LED (AN2)	DIAGNOSTIC
OFF	Control Fault (No Power)
Flash	Blower Fault
ON	Normal Operation

**Table 2. Air handler Control Board Fault Conditions**

DIAGNOSTIC FAULT CONDITIONS FOR VARIABLE SPEED FURNACES	GREEN LED	RED LED
Control Fault (No Power)	Off	Off
Normal Operation	On	On
Motor Fault	On	Flash
Communications Fault	Flash	Flash

**Table 3. VSHE Motor Control Board Display Codes**

## FIGURES & TABLES

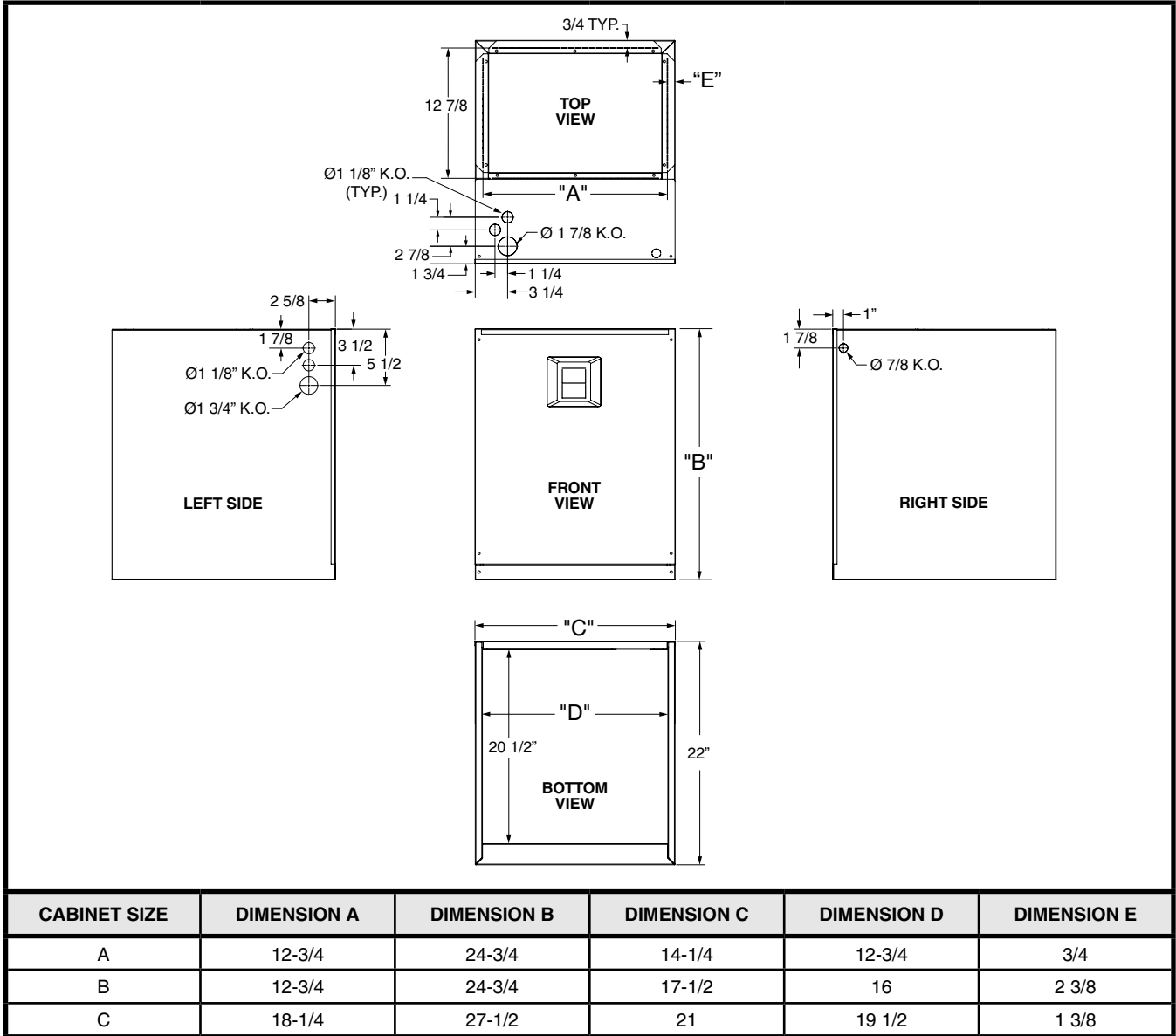

**Figure 7. MB7 Physical Dimensions**

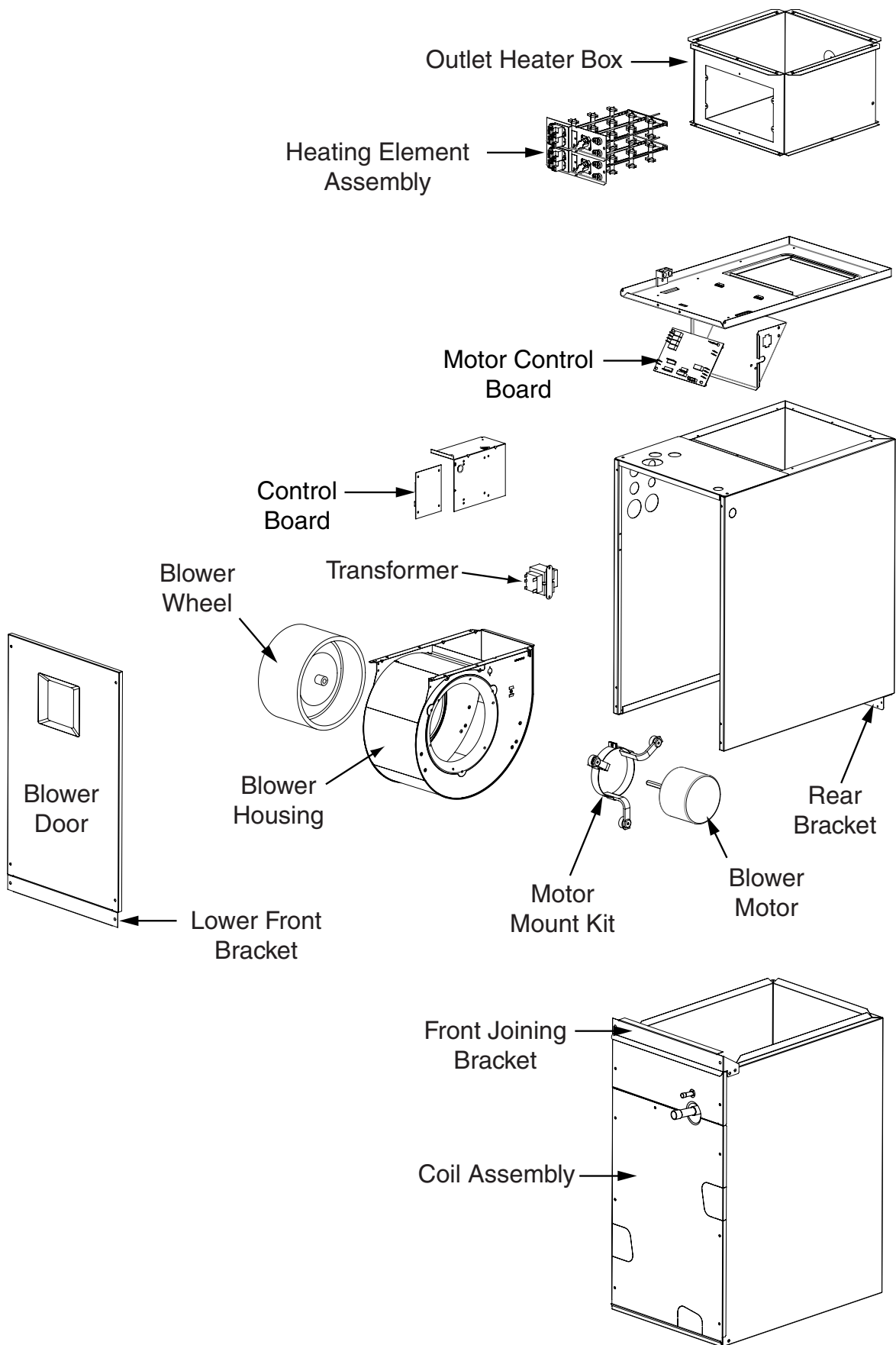

Figure 8. MB7 Component Locations

## Blower Performance Data

CABINET SIZE	SWITCH SETTINGS 0 = OFF, 1 = ON				COOLING OR HEATING AIRFLOW (CFM)							
					DRY COIL ESP							
	1/5	2/6	3/7	4/8	0.1	0.2	0.3	0.4	0.5	0.6	0.7	0.8
<b>MB7EM C-CABINET (460V)</b>	0	0	0	0	677	567	375	—	—	—	—	—
	1	0	0	0	815	690	560	443	367	—	—	—
	0	1	0	0	948	881	766	627	593	516	382	—
	1	1	0	0	1091	1007	924	854	593	675	610	521
	0	0	1	0	1240	1160	1064	984	925	794	758	685
	1	0	1	0	1376	1274	1209	1123	1057	983	909	843
	0	1	1	0	1484	1426	1360	1303	1242	1153	1077	942
	1	1	1	0	1582	1515	1450	1389	1337	1270	1178	1122
	0	0	0	1	1699	1652	1608	1532	1487	1409	1345	1267
	1	0	0	1	1817	1757	1717	1664	1612	1540	1475	1415
	0	1	0	1	1900	1871	1826	1778	1727	1684	1613	1542
	1	1	0	1	1935	1932	1884	1840	1795	1727	1659	1614
	0	0	1	1	2070	2023	2009	1953	1906	1851	1800	1724
	1	0	1	1	2138	2079	2063	2003	1951	1889	1830	1765
	0	1	1	1	2161	2111	2091	2058	2011	1960	1908	1841
1	1	1	1	2249	2209	2189	2169	2126	2074	2031	1961	

**Table 4. MB7EM Airflow Data**

CABINET	NOMINAL ELECTIC HEAT KW	
	460 V	
	9KW	15KW
A	—	—
B	—	—
C	1150	1400

**Table 5. MB7EM (FSHE) Minimum Heating Airflow Settings (CFM)**

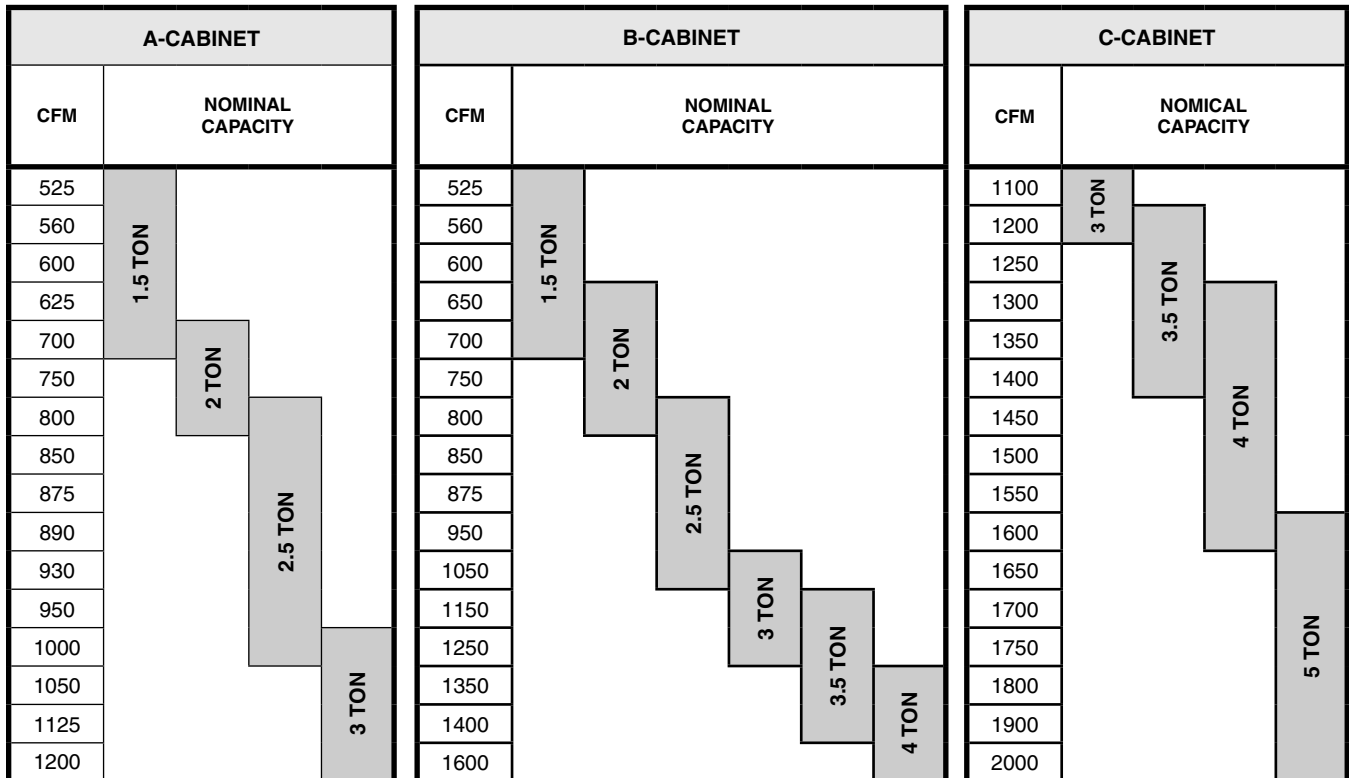

**Table 6. Recommended Cooling Airflow Settings**

MB7VM A-CABINET	COOLING AIRFLOW					AIRFLOW (CFM)
	A/B SWITCH SETTING 0 = OFF, 1 = ON	COOL SWITCH SETTING 0 = OFF, 1 = ON				
		5	6	7	8	
0	0	0	0	0	525	
0	0	0	0	1	560	
0	0	0	1	0	600	
0	0	0	1	1	625	
0	0	1	0	0	700	
0	0	1	0	1	750	
0	0	1	1	0	800	
0	0	1	1	1	850	
0	1	0	0	0	875	
0	1	0	0	1	890	
0	1	0	1	0	930	
0	1	0	1	1	950	
0	1	1	0	0	1000	
0	1	1	0	1	1050	
0	1	1	1	0	1125	
0	1	1	1	1	1200	

HEATING AIRFLOW		
A/B SWITCH SETTING 0 = OFF, 1 = ON	HEATER KIT INSTALLED (KW)	AIRFLOW (CFM)
0	0	600
0	5	800
0	8	1000
0	10	1000
0	15	1300
0	20	N/A
0	25	N/A
0	30	N/A

MB7VM B-CABINET	COOLING AIRFLOW					AIRFLOW (CFM)
	A/B SWITCH SETTING 0 = OFF, 1 = ON	COOL SWITCH SETTING 0 = OFF, 1 = ON				
		5	6	7	8	
1	0	0	0	0	525	
1	0	0	0	1	560	
1	0	0	1	0	600	
1	0	0	1	1	650	
1	0	1	0	0	700	
1	0	1	0	1	750	
1	0	1	1	0	800	
1	0	1	1	1	850	
1	1	0	0	0	875	
1	1	0	0	1	950	
1	1	0	1	0	1050	
1	1	0	1	1	1150	
1	1	1	0	0	1250	
1	1	1	0	1	1350	
1	1	1	1	0	1400	
1	1	1	1	1	1600	

HEATING AIRFLOW		
A/B SWITCH SETTING 0 = OFF, 1 = ON	HEATER KIT INSTALLED (KW)	AIRFLOW (CFM)
1	0	700
1	5	900
1	8	1100
1	10	1100
1	15	1300
1	20	1500
1	25	N/A
1	30	N/A

MB7VM C-CABINET	COOLING AIRFLOW					AIRFLOW (CFM)
	A/B SWITCH SETTING (* = EITHER 0 OR 1)	COOL SWITCH SETTING 0 = OFF, 1 = ON				
		5	6	7	8	
*	0	0	0	0	1100	
*	0	0	0	1	1200	
*	0	0	1	0	1250	
*	0	0	1	1	1300	
*	0	1	0	0	1350	
*	0	1	0	1	1400	
*	0	1	1	0	1450	
*	0	1	1	1	1500	
*	1	0	0	0	1550	
*	1	0	0	1	1600	
*	1	0	1	0	1650	
*	1	0	1	1	1700	
*	1	1	0	0	1750	
*	1	1	0	1	1800	
*	1	1	1	0	1900	
*	1	1	1	1	2000	

HEATING AIRFLOW		
A/B SWITCH SETTING (* = EITHER 0 OR 1)	HEATER KIT INSTALLED (KW)	AIRFLOW (CFM)
*	0	800
*	5	1000
*	8	1200
*	10	1200
*	15	1400
*	20	1600
*	25	N/A
*	30	N/A

**NOTES:**

- Airflow values listed are for 240V operation. For 208V operation, multiply A & B cabinet values by .95; for C-cabinet values multiply by .90
- When matched with two-stage outdoor units the airflow on low (Y1 or W1) input only will be 70% of the values shown in this table.

**Table 7. MB7VM (VSHE) Airflow Data**

## Electrical Data & Diagrams

MINIMUM CIRCUIT AMPACITY & MAXIMUM OVERCURRENT PROTECTION											
MODEL	VOLTAGE, HZ, & PHASE	CABINET SIZE	CAPACITY	MCA				MOP			
				CIRCUIT A	CIRCUIT B	CIRCUIT C	SINGLE CIRCUIT	CIRCUIT A	CIRCUIT B	CIRCUIT C	SINGLE CIRCUIT
<b>MB7VM</b>	240 VAC, 50 & 60 Hz, Single Phase	A	1,200 CFM	4.5	-	-	4.5	15	-	-	15
		B	1,600 CFM	4.5	-	-	4.5	15	-	-	15
		C	2,000 CFM	6.3	-	-	6.3	15	-	-	15
	208 VAC, 50 & 60 Hz, Single Phase	A	1,200 CFM	4.8	-	-	4.8	15	-	-	15
		B	1,600 CFM	4.8	-	-	4.8	15	-	-	15
		C	2,000 CFM	6.8	-	-	6.8	15	-	-	15
<b>MB7EM</b>	460V 50 & 60 Hz, Three Phase	C	2,000 CFM	4.1	-	-	4.1	15	-	-	15

**NOTE:** Circuit ampacity slightly higher for variable speed. See label on blower.

**Table 8. MB7VM MCA & MOP Data**

CONTROL SIGNAL & MODE	OPERATION	TOTAL KW	BOARD ACTION		
W1 ONLY EHEAT	ON	5 KW	Stage 1 Heat on instantly		
			Heat blower on after 3 second delay		
		10 KW	Stage 1 Heat on instantly		
			Heat blower on after 3 second delay		
		15 KW	Stage 1 Heat on instantly		
			Heat blower on after 3 second delay		
		20 KW	Stage 2 Heat on after 5 second delay		
			Stage 3 Heat on after 10 second delay		
	OFF	Heat stages off instantly			
		Blower off after 15 second delay			
W1 & W2 EHEAT	ON	5 KW	Stage 1 Heat on instantly		
			Heat blower on after 3 second delay		
		10 KW	Stage 1 Heat on instantly		
			Heat blower on after 3 second delay		
		15 KW	Stage 2 Heat on after 5 seconds delay		
			Stage 1 Heat on instantly		
		20 KW	Heat blower on after 3 second delay		
			Stage 2 Heat on after 5 seconds delay		
		OFF	Stage 3 Heat on after 10 seconds delay		
			Blower off after 15 second delay		
		W1 & Y/Y2 AUX HEAT	ON	5 KW	Stage 1 Heat on instantly
					Cool blower on after 3 second delay
	10 KW			Stage 1 Heat on instantly	
				Cool blower on after 3 second delay	
15 KW	Stage 1 Heat on instantly				
	Cool blower on after 3 second delay				
20 KW	Stage 2 Heat on after 5 seconds delay				
	Stage 3 Heat on after 10 seconds delay				
OFF	Heat stages off instantly				
	Heat blower turns off after 40 second delay				
W1, W2 & Y/Y2 AUX HEAT	ON			5 KW	Stage 1 Heat on instantly
					Cool blower on after 3 second delay
			10 KW	Stage 1 Heat on instantly	
				Cool blower on after 3 second delay	
		15 KW	Stage 2 Heat on after 5 seconds delay		
			Stage 1 Heat on instantly		
		20 KW	Cool blower on after 3 second delay		
			Stage 2 Heat on after 5 seconds delay		
		OFF	Stage 3 Heat on after 30 seconds delay		
			Heat stages off instantly		
		Heat blower turns off after 40 second delay			

Table 9. MB7(EM, VM) Heating Element Logic

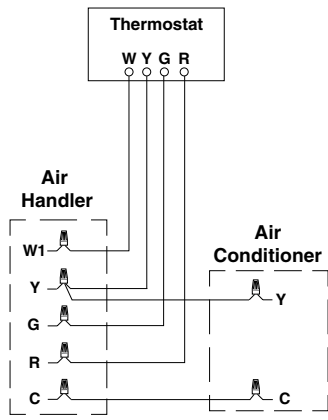

Typical Air Conditioner with Standard Air Handler

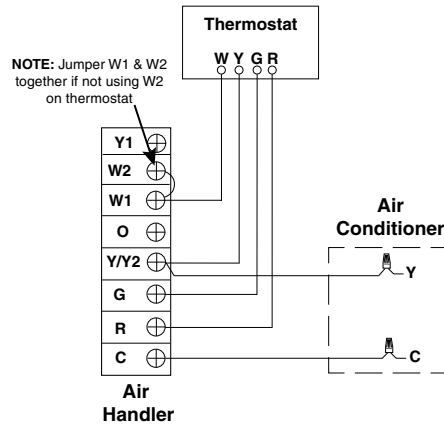

Typical Air Conditioner with Variable Speed Air Handler

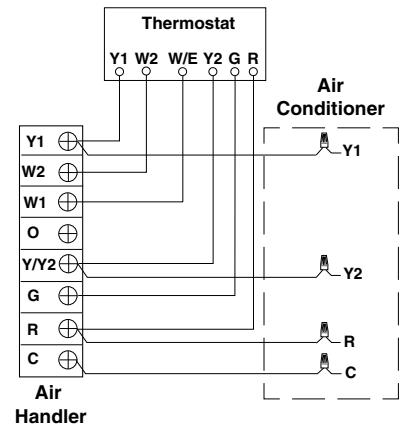

Typical 2-Stage Air Conditioner with Variable Speed Air Handler

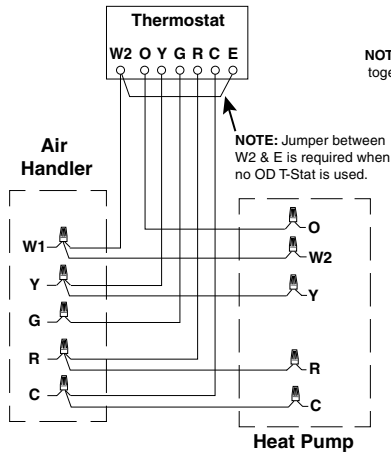

Typical Heat Pump with Standard Air Handler

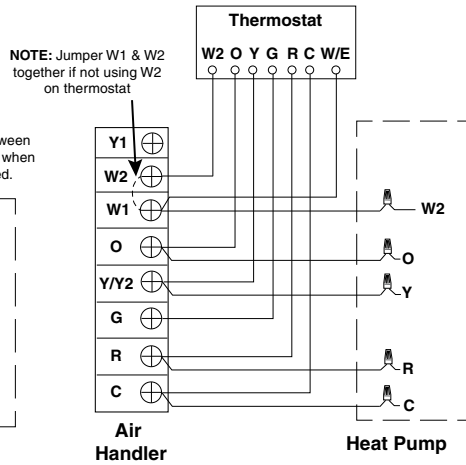

Typical Heat Pump with Variable Speed Air Handler

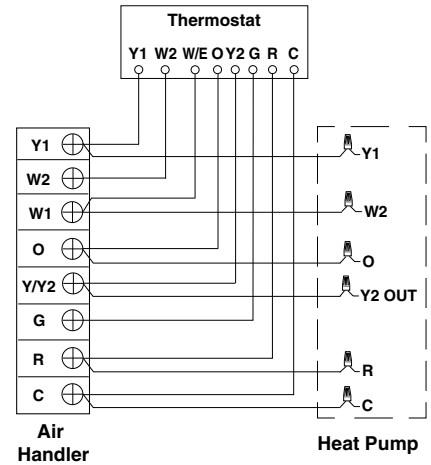

Typical 2-Stage Heat Pump with Variable Speed Air Handler

Figure 9. Typical Thermostat Connections

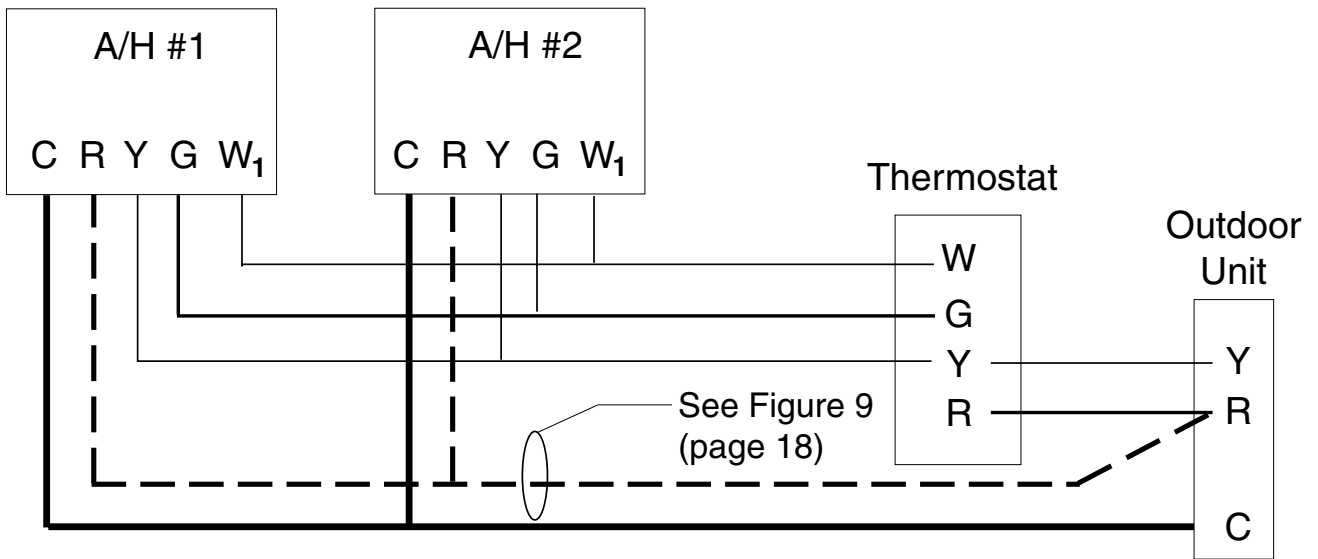

Figure 10. Low Voltage Wiring For Twinning

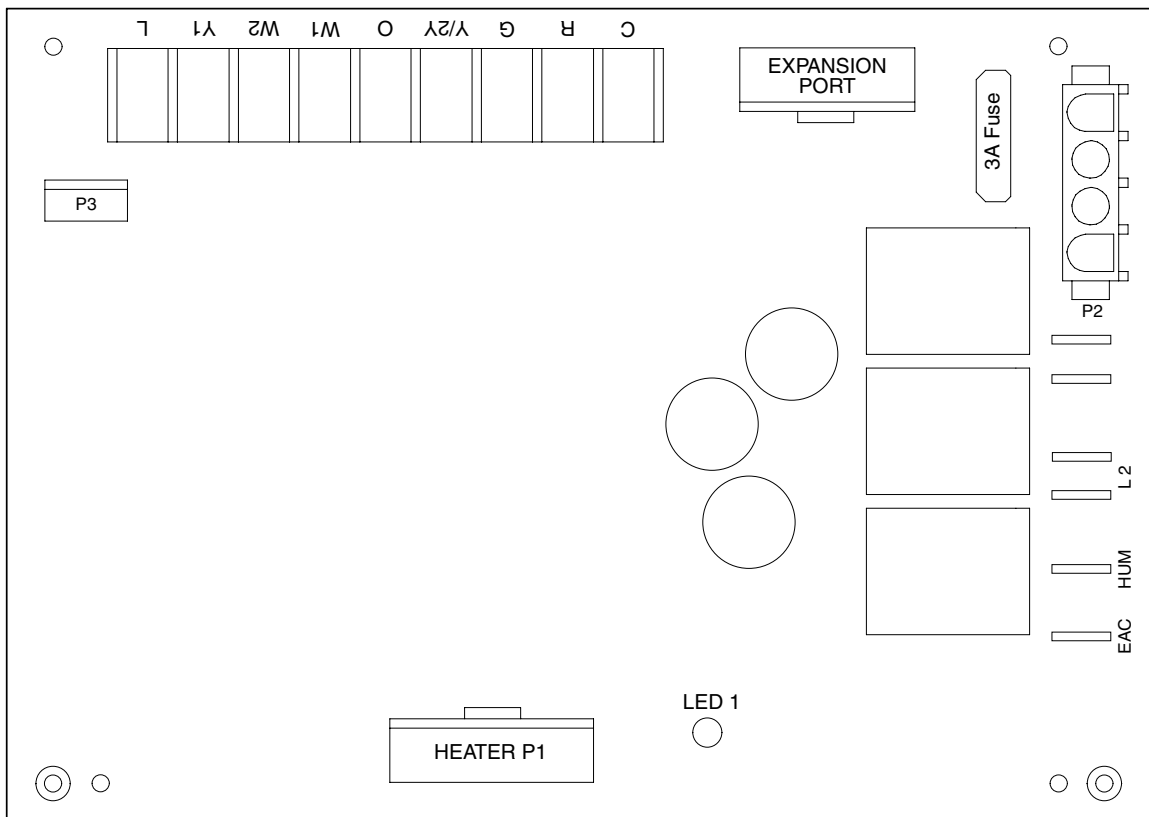

Figure 11. Two - Stage Control Board (All Models)

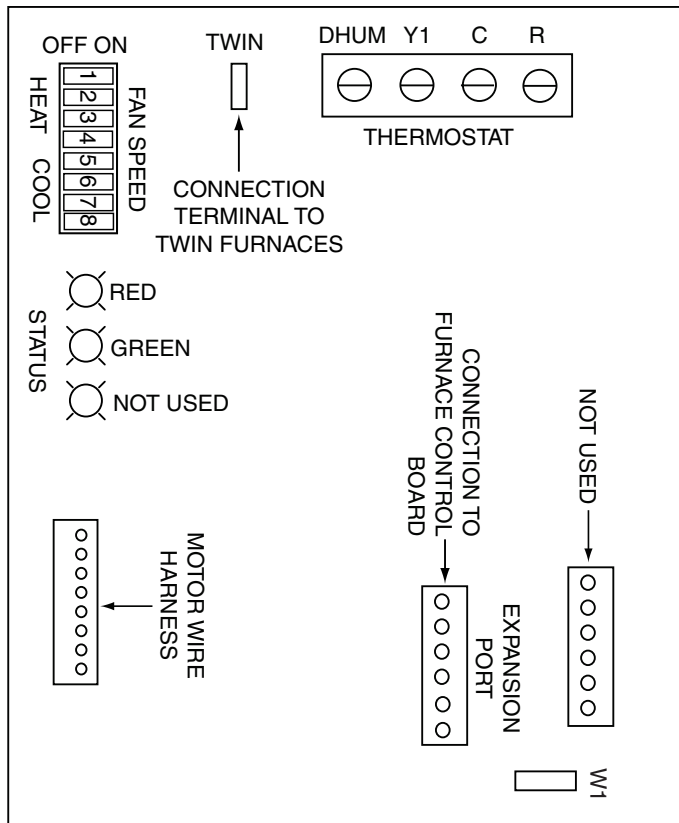

Figure 12. Fixed Speed Motor Control Board (MB7EM Models)

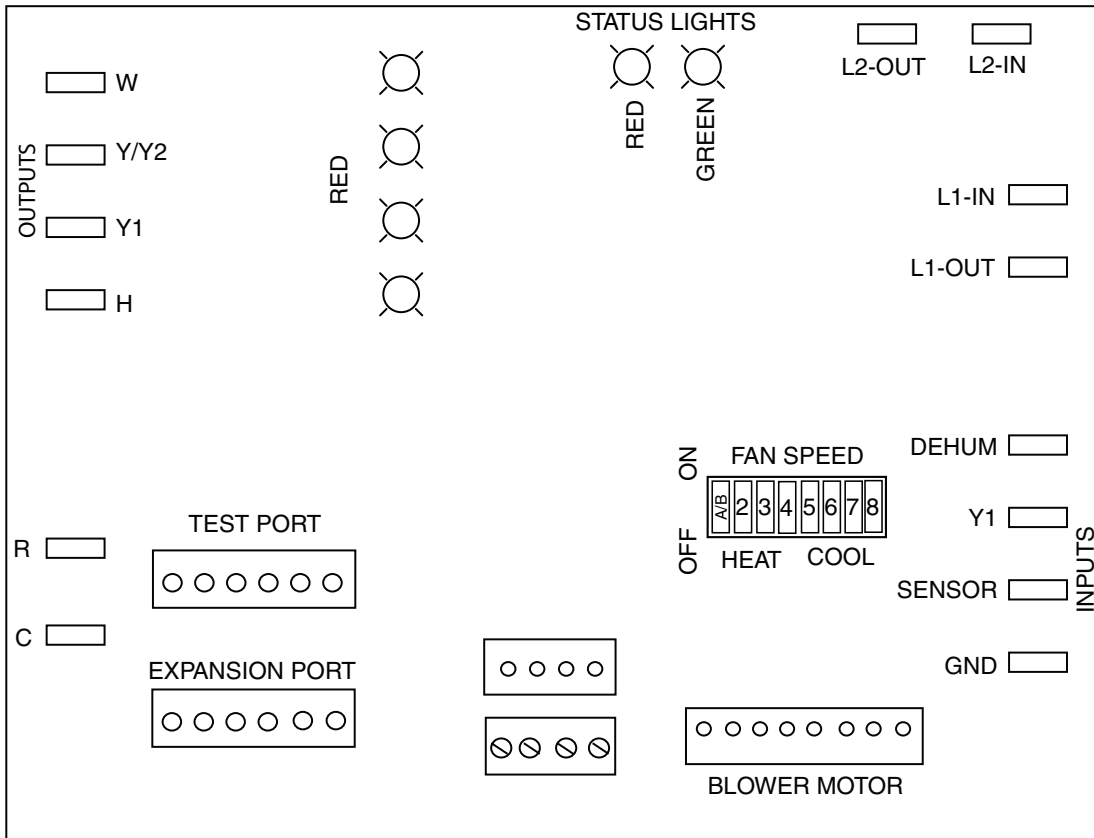

Figure 13. Variable Speed Motor Control Board (MB7VM Models)

# WIRING DIAGRAM

## Modular Air Handle With Fixed Speed High Efficiency Motor

460V 3 Phase/ 60 Hz

### NOTES:

1. The blower motor speed tap connection may not be as shown. See the Installation Instructions.
2. Disconnect all power before servicing.

### Remarques

1. Le connecteur de vitesse du moteur du ventilateur peut différer de l'illustration. Consultez les Instructions d'installation.
2. Débranchez toutes les sources d'alimentation avant l'entretien.
3. Transformer may have a dual voltage primary tap. Match the tap position with the supply voltage used.
4. If the internal wiring is replaced, use only 105°C copper wire of the same gauge.

3. Le transformateur peut avoir un robinet principal à double tension. Agencez la position du robinet au type de tension de l'installation.
4. Si le câblage interne est remplacé, utilisez seulement un fil de cuivre 105° C du même gabarit.

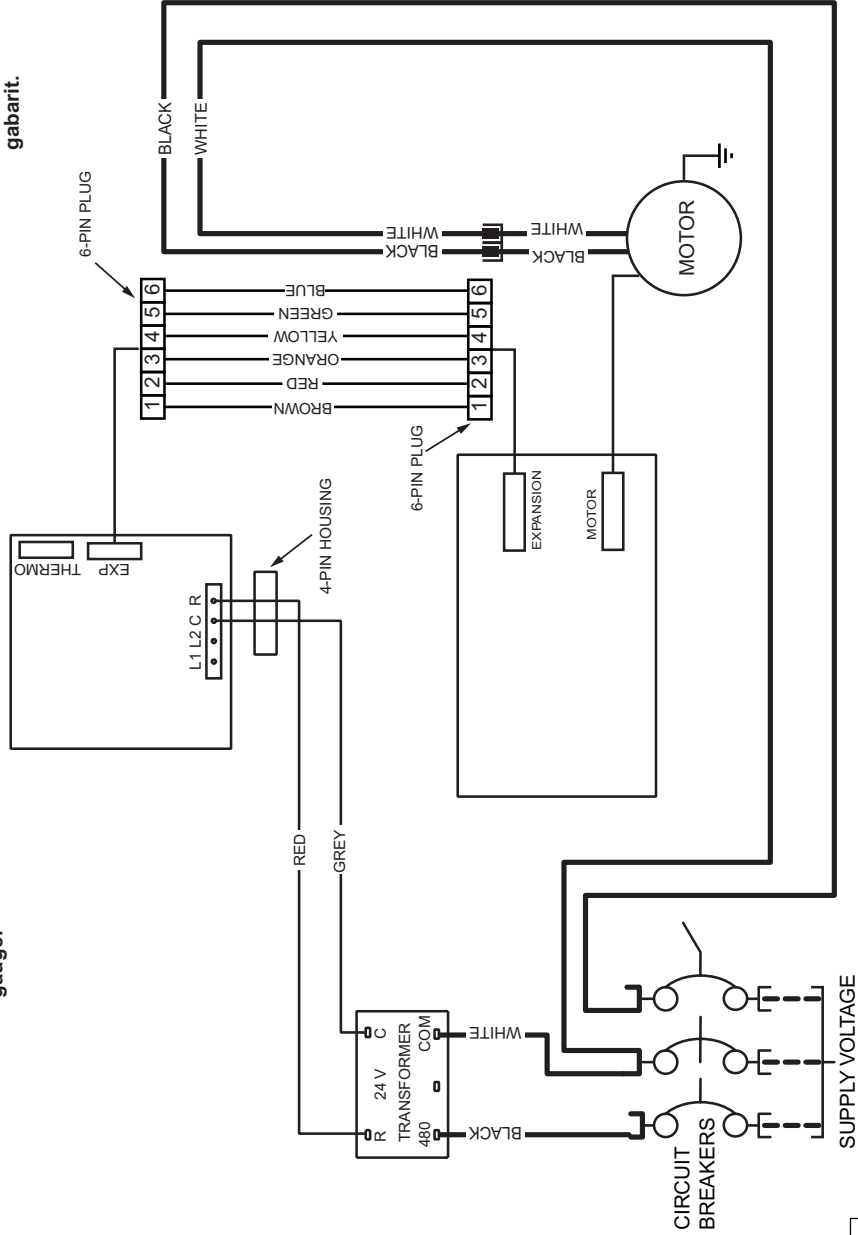

### LEGEND:

- FIELD WIRING - - - - -
- LOW VOLTAGE ———
- HIGH VOLTAGE ———



10177230  
(Replaces 1007276A)  
03/17

Figure 14. MB7EM (460 V) Wiring Diagram

# WIRING DIAGRAM

## Air Handler with Variable Speed High Efficiency Motor

### NOTES:

1. The blower motor speed tap connection may not be as shown. See the Installation Instructions.
2. Disconnect all power before servicing.
3. Transformer may have a dual voltage primary tap. Match the tap position with the supply voltage used.
4. If the internal wiring is replaced, use only 105°C copper wire of the same gauge.

### Remarques

1. Le connecteur de vitesse du moteur du ventilateur peut différer de l'illustration. Consultez les Instructions d'installation.
2. Débranchez toutes les sources d'alimentation avant l'entretien.
3. Le transformateur peut avoir un robinet principal à double tension. Agencez la position du robinet au type de tension de l'installation.
4. Si le câblage interne est remplacé, utilisez seulement un fil de cuivre 105° C du même gabarit.

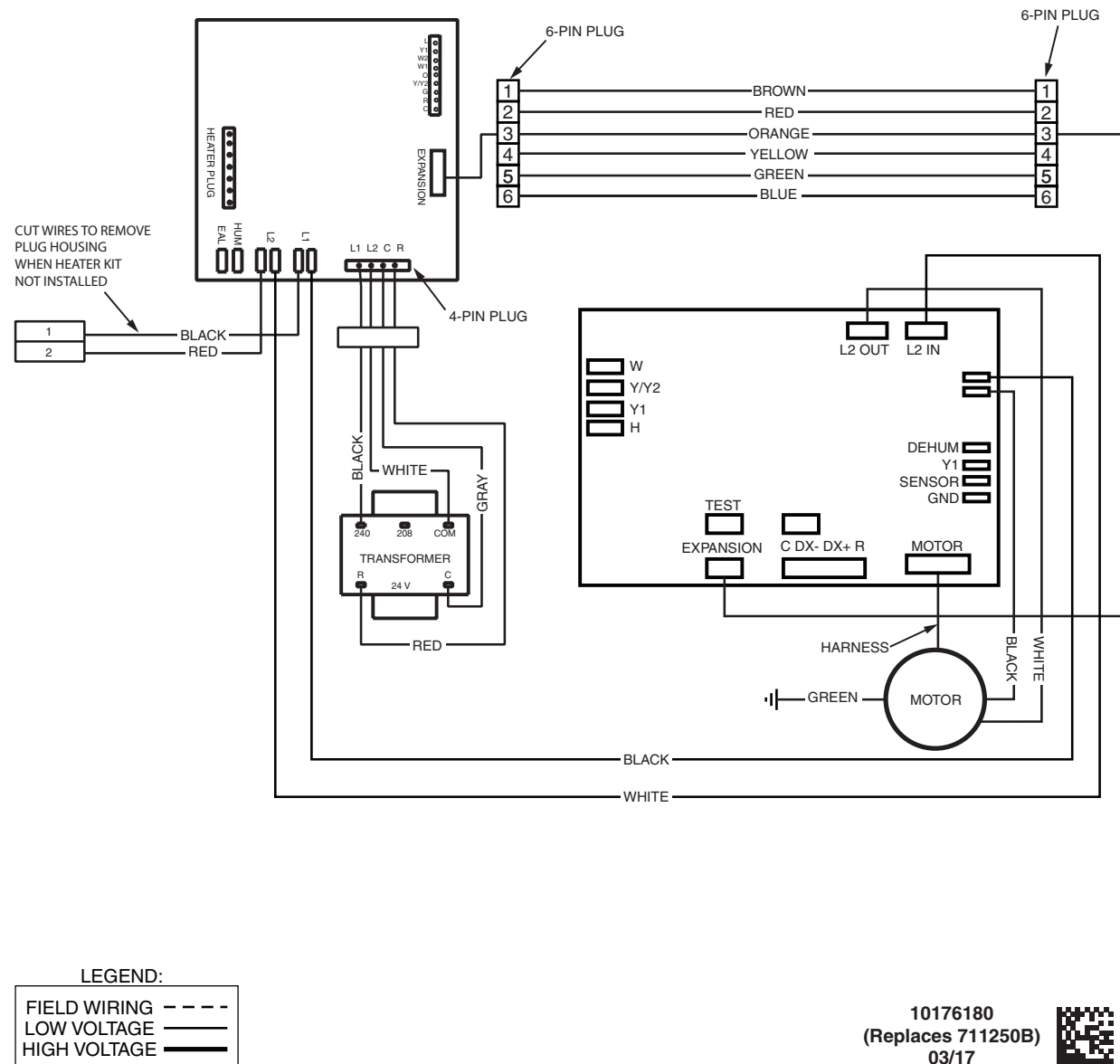

Figure 15. MB7VM Wiring Diagram



## INSTALLATION CHECKLIST

<b>INSTALLER NAME:</b>		
CITY:	STATE:	
<b>INSTALLATION ADDRESS:</b>		
CITY:	STATE:	
UNIT MODEL #		
UNIT SERIAL #		
Minimum clearances per <a href="#">page 4</a> ?	YES	NO
Is the unit properly installed and leveled?	YES	NO
Does condensate drain properly in both drain tubes?	YES	NO
Has the owner's information been reviewed with the home-owner?	YES	NO
Has the literature package been left near the appliance?	YES	NO

ELECTRICAL SYSTEM		
Electrical connections tight?	YES	NO
Line voltage polarity correct?	YES	NO
Supply Voltage: _____(V)		
Has the thermostat been calibrated?	YES	NO
Is the thermostat level?	YES	NO
Is the heat anticipator setting correct?	YES	NO

**ATTENTION INSTALLERS:**

It is your responsibility to know this product better than your customer. This includes being able to install the product according to strict safety guidelines and instructing the customer on how to operate and maintain the equipment for the life of the product. Safety should always be the deciding factor when installing this product and using common sense plays an important role as well. Pay attention to all safety warnings and any other special notes highlighted in the manual. Improper installation of the furnace or failure to follow safety warnings could result in serious injury, death, or property damage.

These instructions are primarily intended to assist qualified individuals experienced in the proper installation of this appliance. Some local codes require licensed installation/service personnel for this type of equipment. Please read all instructions carefully before starting the installation. Return these instructions to the customer's package for future reference.

