

INSTALLATION INSTRUCTIONS

Single Stage - Direct Vent (Sealed Combustion) Forced Air



Front Return
without
Coil Box

Front Return
with Coil Box

Top Return
with Coil Box

Top Return
without
Coil Box

For Installation in:

- Manufactured Homes
- Modular Homes / Buildings
- Park Models, & Manufactured Buildings

⚠ CAUTION

HUD Manufactured Home Construction and Safety Standards (3280.714) prohibit the use of noncertified air conditioning or heat pump equipment with this furnace. It is strongly recommended that manufactured housing air conditioning components from Nortek Global HVAC be selected to provide a matched system specifically designed to meet these requirements.

The cutting, splicing or modifying of any internal electrical wiring may void product warranties and create a hazardous condition. Failure to comply with these standards could also provide inadequate heating or cooling performance and cause structural damage to a manufactured home.

Please contact your local distributor for help. A directory of Nortek Global HVAC factory authorized servicers is located in the furnace homeowner packet.

Reference: HUD Manufactured Home Construction and Safety Standards 3280.714.

⚠ WARNING

FIRE OR EXPLOSION HAZARD

- Failure to follow safety warnings exactly could result in serious injury or property damage.
- Installation and service must be performed by a qualified installer, service agency or the gas supplier.
- Do not store or use gasoline or other flammable vapors and liquids in the vicinity of this or any other appliance.

WHAT TO DO IF YOU SMELL GAS

- Do not try to light any appliance.
- Do not touch any electrical switch; do not use any phone in your building.
- Leave the building immediately.
- Immediately call your gas supplier from a neighbors phone. Follow the gas suppliers instructions.
- If you cannot reach your gas supplier, call the fire department.

⚠ AVERTISSEMENT

RISQUE D'INCENDIE OU D'EXPLOSION

- Le non-respect des avertissements de sécurité pourrait entraîner des blessures graves ou des dommages matériels.
- L'installation et l'entretien doivent être effectués par un installateur qualifié, un organisme de service ou le fournisseur de gaz.
- Ne pas entreposer ni utiliser de l'essence ni d'autres vapeurs ou liquides inflammables dans le voisinage de cet appareil, ni de tout autre appareil.

QUE FAIRE S'IL Y A UNE ODEUR DE GAZ

- Ne tenter d'allumer aucun appareil.
- Ne toucher à aucun interrupteur électrique; n'utiliser aucun téléphone dans le bâtiment.
- Évacuer l'immeuble immédiatement.
- Appeler immédiatement le fournisseur de gaz en employant le téléphone d'un voisin. Respecter les instructions du fournisseur de gaz.
- Si personne ne répond, appeler le service des incendies.

**DO NOT DESTROY. PLEASE READ CAREFULLY & KEEP IN A SAFE PLACE FOR FUTURE REFERENCE.
NE PAS DÉTRUIRE. VEUILLEZ LIRE ATTENTIVEMENT ET CONSERVER EN UN LIEU SÛR POUR RÉFÉRENCE ULTÉRIEURE.**

TABLE OF CONTENTS

IMPORTANT SAFETY INFORMATION	3	ELECTRICAL WIRING	23
GENERAL INFORMATION	4	Line Voltage Wiring	23
Requirements & Codes	4	Thermostat / Low Voltage Connections	23
Clearances to Combustible Materials	5	Heat Anticipator	24
Combustion Air Quality	5	Grounding.....	24
Heating Load	5	START-UP & ADJUSTMENTS	25
Condensate Disposal	5	Pre-Start Check List	25
COMBUSTION AIR & VENTING REQUIREMENTS .	6	Start-up Procedures	25
Important Information	7	Verifying Input Rate	25
Category IV Appliances.....	7	Verifying & Adjusting Temperature Rise.....	25
Direct Vent Installation.....	7	Verifying Burner Operation.....	26
Vent Pipe Length & Diameter	7	Verifying Operation of the Supply Air Limit Switch .	26
Vent Pipe Material	8	OPERATING SEQUENCE	27
Vent Pipe Installation	8	Heating Cycle	27
Outdoor Terminations - Horizontal Venting	8	Cooling Cycle	27
Outdoor Terminations - Vertical Venting.....	9	Fan Mode	27
Vent Freezing Protection	10	MAINTENANCE	27
Existing Installations.....	10	Air Filter(s).....	28
Ventilare III or IV Air Quality Package	10	Blower Compartment.....	28
CIRCULATING AIR REQUIREMENTS	11	Cleaning of Burners.....	28
Plenums & Air Ducts	11	Vent System	28
Supply Air Connections.....	11	Heat Exchanger & Burner Maintenance.....	28
Return Air Connections	11	Lubrication.....	28
Closet & Alcove Installations	12	TROUBLESHOOTING	29
Furnace Filter	12	DESCRIPTION OF COMPONENTS	29
Dampers.....	13	FIGURES & TABLES	30
Acoustical Treatments	13	Cabinet Dimensions	30
FURNACE INSTALLATION	14	Figure 24. A-Size Cabinets (Front Return)	30
About The Furnace.....	14	Figure 25. B-Size Cabinets (Front Return)	31
Before You Install this Furnace.....	14	Figure 26. A-Size Cabinets (Top Return Air)	32
Locating the Unit	14	Figure 27. B-Size Cabinets (Top Return Air)	33
Locating & Cutting Floor Openings	15	Electrical Information.....	34
Locating & Cutting Ceiling Openings.....	15	Figure 28. M7RL Wiring Diagram	34
Installing Finger Tabbed Duct Connectors	15	Gas Information.....	35
Narrow Duct Attachment - Option 1.....	16	Table 8. Gas Flow Rates.....	35
Narrow Duct Attachment - Option 2.....	16	Table 9. Gas Pipe Capacities.....	35
Installing Screw-Down Duct Connectors.....	17	Table 10. Orifices for Propane Gas.....	36
Round Duct Connector Installation	17	Table 11. Natural Gas Heating Values	36
Installing the Furnace	17	Table 12. Orifices for Natural Gas	
Condensate Drainage	17	High Heating Value.....	36
GAS SUPPLY & PIPING	18	Table 13. Orifices for Natural Gas	
Leak Check	19	Low Heating Value	36
Converting to LP/Propane Gas at Altitudes		Venting Information	37
between 0 & 10,000 FT.	20	Table 14. Vent Termination Clearances.....	37
High Altitude Application	20	Figure 29. Horizontal / Vertical Venting &	
Removing The Burner Orifices	21	Clearances from Soffit.....	38
Gas Pressure Verification.....	21	INSTALLATION CHECKLIST	40
Measuring the Supply Gas Pressure.....	21		
Lighting & Adjustment of the Appliance.....	22		
Measuring the Manifold Pressure.....	22		
Removing the Manometer/Pressure Gauge	22		
Completing the Conversion	22		

IMPORTANT SAFETY INFORMATION

INSTALLER: Please read all instructions before servicing this equipment. Pay attention to all safety warnings and any other special notes highlighted in the manual. Safety markings are used frequently throughout this manual to designate a degree or level of seriousness and should not be ignored.

WARNING indicates a potentially hazardous situation that if not avoided, could result in personal injury or death.

CAUTION indicates a potentially hazardous situation that if not avoided, may result in minor or moderate injury or property damage.

- To minimize equipment failure or personal injury, it is essential that only qualified individuals install, service, or maintain this equipment. If you do not possess mechanical skills or tools, call your local dealer for assistance.
- Follow all precautions in the literature, on tags, and on labels provided with the equipment. Read and thoroughly understand the instructions provided with the equipment prior to performing the installation and operational checkout of the equipment.
- Use caution when handling this appliance or removing components. Personal injury can occur from sharp metal edges present in all sheet metal constructed equipment.
- Do not store any of the following on, or in contact with, the unit: Rags, brooms, vacuum cleaners, or other cleaning tools, spray or aerosol cans, soap powders, bleaches, waxes, cleaning compounds, plastics or plastic containers, paper bags or other paper products, gasoline, kerosene, cigarette lighter fluid, dry cleaning fluids, paint thinners, or other volatile fluids.
- Installation of equipment may require brazing operations. Installer must comply with safety codes and wear appropriate safety equipment (safety glasses, work gloves, fire extinguisher, etc.) when performing brazing operations.
- The installer should become familiar with the units wiring diagram before making any electrical connections to the unit. See the unit wiring label or [Figure 28 \(page 34\)](#).
- Always reinstall the doors on the indoor blower after servicing or cleaning/changing the filters. Do not operate the indoor blower without all doors and covers in place.

WARNING:

The safety information listed in this manual must be followed during the installation, service, and operation of this unit. Unqualified individuals should not attempt to interpret these instructions or install this equipment. Failure to follow safety recommendations could result in possible damage to the equipment, serious personal injury or death.

WARNING:

ELECTRICAL SHOCK, FIRE OR EXPLOSION HAZARD

Failure to follow safety warnings exactly could result in serious injury or property damage.

Improper servicing could result in dangerous operation, serious injury, death or property damage.

- Before servicing, disconnect all electrical power to the indoor blower.
 - When servicing controls, label all wires prior to disconnecting. Reconnect wires correctly.
 - Verify proper operation after servicing.
-

WARNING:

FIRE OR EXPLOSION HAZARD

- Failure to follow safety warnings exactly could result in serious injury or property damage.
- Installation and service must be performed by a qualified installer, service agency or the gas supplier.
- Do not store or use gasoline or other flammable vapors and liquids in the vicinity of this or any other appliance.

WHAT TO DO IF YOU SMELL GAS

- Do not try to light any appliance.
 - Do not touch any electrical switch; do not use any phone in your building.
 - Leave the building immediately.
 - Immediately call your gas supplier from a neighbor's phone. Follow the gas supplier's instructions.
 - If you cannot reach your gas supplier, call the fire department.
-

WARNING:

Improper installation, service, adjustment, or maintenance may cause explosion, fire, electrical shock or other hazardous conditions which may result in personal injury or property damage. Unless otherwise noted in these instructions, only factory authorized kits or accessories may be used with this product.

WARNING:

Unless otherwise noted in these instructions, only factory authorized kits or accessories may be used with or when modifying this product.

GENERAL INFORMATION

Requirements & Codes

WARNING:

This unit must be installed in accordance with instructions outlined in this manual during the installation, service, and operation of this unit. Unqualified individuals should not attempt to interpret these instructions or install this equipment. Failure to follow safety recommendations could result in possible damage to the equipment, serious personal injury or death.

- The installer must comply with all local codes and regulations which govern the installation of this type of equipment. Local codes and regulations take precedence over any recommendations contained in these instructions. Consult local building codes and the National Electrical Code (NFPA 70) for special installation requirements.
 - All electrical wiring must be completed in accordance with local, state and national codes and regulations and with the National Electric Code (NFPA 70) or in Canada the Canadian Electric Code Part 1 CSA C.22.1.
 - This furnace must be installed in accordance with these instructions, all applicable local building codes and the current revision of the National Fuel Gas Code (NFPA54/ANSI Z223.1) or the Natural Gas and Propane Installation Code, CAN/CGA B149.1.
 - Use only with type of gas approved for this furnace. Refer to the furnace rating plate.
 - Install this furnace only in a location and position as specified on [page 5](#).
 - Provide adequate combustion and ventilation air to the furnace space as specified on [pages 6 - 7](#).
 - Provide adequate clearances around the vent air intake terminal as specified in [Figure 1](#), [Figure 2](#), [Figure 3](#), and [Figure 4](#) ([page 9](#)).
 - Combustion products must be discharged outdoors. Connect this furnace to an approved vent system only, as specified on [pages 7 - 10](#).
 - Never test for gas leaks with an open flame. Use a commercially available soap solution to check all connections. See [page 19](#).
 - This furnace is designed to operate with a maximum external pressure rise of 0.3 inches of water column. Consult [Table 6](#), ([page 26](#)) and the rating plate for the proper circulating air flow and temperature rise. It is important that the duct system be designed to provide the correct flow rates and external pressure rise. An improperly designed duct system can result in nuisance shutdowns, and comfort or noise issues.
 - This furnace must not be used for temporary heating of buildings or structures under construction.
- The Commonwealth of Massachusetts requires compliance with regulation 248 CMR 4.00 and 5.00 for installation of through-the-wall vented gas appliances as follows:
 1. For direct-vent appliances, mechanical-vent heating appliances or domestic hot water equipment, where the bottom of the vent terminal and the air intake is installed below four feet above grade the following requirements must be satisfied:
 - a.) A carbon monoxide (CO) detector and alarm shall be placed on each floor level where there are bedrooms. The detector shall comply with NFPA 720 (2005 Edition) and be mounted in the living area outside the bedroom(s).
 - b.) A (CO) detector shall be located in the room that houses the appliance or equipment and shall:
 - Be powered by the same electrical circuit as the appliance or equipment. Only one service switch shall power the appliance and the (CO) detector;
 - Have battery back-up power;
 - Meet ANSI/UL 2034 Standards and comply with NFPA 720 (2005 Edition); and Approved and listed by a Nationally Recognized Testing Laboratory as recognized under 527 CMR.
 - c.) A Product-approved vent terminal must be used, and if applicable, a product-approved air intake must be used. Installation shall be in strict compliance with the manufacturer's instructions. A copy of the installation instructions shall remain with the appliance or equipment at the completion of the installation.
 - d.) A metal or plastic identification plate shall be mounted at the exterior of the building, 4 feet directly above the location of vent terminal. The plate shall be of sufficient size, easily read from a distance of eight feet away, and read "Gas Vent Directly Below".
 2. For direct-vent appliances, mechanical vent heating appliances or domestic hot water equipment where the bottom of the vent terminal and the air intake is installed above four feet above grade the following requirements must be satisfied:
 - a.) A (CO) detector and alarm shall be placed on each floor level where there are bedrooms. The detector shall comply with NFPA 720 (2005 Edition) and be mounted in the living area outside the bedroom(s).
 - b.) The (CO) detector shall:
 - Be located in the room that houses the appliance or equipment;
 - Be hard-wired, battery powered or both.
 - Shall comply with NFPA 720 (2005 Edition).
 - c.) A product-approved vent terminal must be used, and if applicable, a product-approved air intake must be used. Installation shall be in strict compliance with the manufacturer's instructions. A copy of the installation instructions shall remain with the appliance or equipment at the completion of the installation.

Clearances to Combustible Materials

This furnace is Design Certified in the U.S. and Canada for the minimum clearances to combustible materials. **NOTE:** The furnace is listed for installation on combustible or non-combustible flooring. However, wood is the only combustible flooring allowed for installation. To obtain furnace base model number and specific clearance information, refer to the furnace rating plate, located inside of the furnace cabinet.

Access for positioning and servicing the unit must be considered when locating unit. The need to provide clearance for access to panels or doors may require clearance distances over and above the requirements. **Allow 18 inches minimum clearance from the front of the unit. However 36 inches is strongly recommended.** See [Table 1](#) for minimum clearance requirements.

The ductwork should be appropriately sized to the capacity of the furnace to ensure its proper airflow rating. For installations above 2,000 ft., the furnace should have a sea level input rating large enough that it will meet the heating load after deration for altitude.

INSTALLATION CLEARANCES		
	CLOSET	ALCOVE
Front *	1"	1"
Rear	0"	0"
Sides	0"	0"
Top	6"	6"
Duct w/in 3ft of furnace	1/4"	1/4"
Vent	0"	0"
Plenum Without Coil Box	1"	1"
Plenum With Coil Box	0"	0"

NOTES:

Alcove Installations - Allow 18 in. minimum clearance from front of unit to nearest wall or partition for servicing.

Closest installations - Require a return air grill installed in the door or a partially louvered door across the opening for proper air circulation. For clearances 6" or greater, the closet must have an open free area of 235 in² minimum. For special clearances between 1" & 6", requirements are a louvered door with a minimum of 250 in² (1613 cm²) free area. For 1" clearance from furnace, use a fully louvered door with at least 400 in² of free airflow area. A fully louvered closet door is strongly recommended for all installation types.

Table 1. Minimum Clearances

Combustion Air Quality

⚠ CAUTION:

Combustion air must not be drawn from a corrosive atmosphere.

To maximize heat exchanger life, the combustion air must be free of chemicals that can form corrosive acidic compounds in the combustion gases. The required source of combustion air is to use outdoor air.

If outside air is used as return air to the furnace for ventilation or to improve indoor air quality, the system must be designed so that the return air is not less than 60° F (15° C) during operation. If a combination of indoor and outdoor air is used, the ducts and damper system must be designed so that the return air supply to the furnace is equal to the return air supply under normal, indoor return air applications.

Exposure to the following substances in the combustion air supply will result in safety and performance related problems. The list below contains examples of chemical containments found in a wide variety of common commercial household products:

- Permanent wave solutions
- Chlorinated waxes and cleaners
- Chlorine based swimming pool chemicals
- Water softening chemicals
- De-icing salts or chemicals
- Carbon Tetrachloride
- Halogen type refrigerants
- Cleaning solvents (perchloroethylene)
- Printing inks, paint removers, varnishes, etc.
- Hydrochloric Acid
- Cements and glues
- Antistatic fabric softeners
- Masonry acid washing materials

Heating Load

This furnace should be sized to provide the design heating load requirement. Heating load estimates can be made using approved methods available from Air Conditioning Contractors of America (Manual J); American Society of Heating, Refrigerating, and Air Conditioning Engineers; or other approved engineering methods. **Excessive oversizing of the furnace could cause the furnace and/or vent to fail prematurely.**

Condensate Disposal

The method for disposing of condensate varies according to local codes. Consult your local code or authority having jurisdiction. Neutralizer kit P/N [902377](#) is available for use with this furnace. **Please follow the instructions provided with the kit.**

COMBUSTION AIR & VENTING REQUIREMENTS

WARNING:

CARBON MONOXIDE POISONING HAZARD

Failure to follow the steps outlined below for each appliance connected to the venting system being placed into operation could result in carbon monoxide poisoning or death. The following steps shall be followed with each individual appliance connected to the venting system being placed in operation, while all other appliances connected to the venting system are not in operation:

1. Seal any unused openings in the venting system.
2. Inspect the venting system for proper size and horizontal pitch, as required in the National Fuel Gas Code, ANSI Z223.1/NFPA 54 or the CSA B149.1, Natural Gas and Propane Installation Codes and these instructions. Determine that there is no blockage or restriction, leakage, corrosion and other deficiencies which could cause an unsafe condition.
3. As far as practical, close all building doors and windows and all doors between the space in which the appliance(s) connected to the venting system are located and other spaces of the building.
4. Close fireplace dampers.
5. Turn on clothes dryers and any appliance not connected to the venting system. Turn on any exhaust fans, such as range hoods and bathroom exhausts, so they are operating at maximum speed. Do not operate a summer exhaust fan.
6. Follow the lighting instructions. Place the appliance being inspected into operation. Adjust the thermostat so appliance is operating continuously.
7. Test for spillage from draft hood equipped appliances at the draft hood relief opening after 5 minutes of main burner operation. Use the flame of a match or candle.
8. If improper venting is observed during any of the above tests, the venting system must be corrected in accordance with the National Fuel Gas Code, ANSI Z223.1/NFPA 54 and/or CSA B149.1, Natural Gas and Propane Installation Codes.
9. After it has been determined that each appliance connected to the venting system properly vents when tested as outlined above, return doors, windows, exhaust fans, fireplace dampers and any other gas-fired burning appliance to their previous conditions of use.

AVERTISSEMENT:

RISQUE D'EMPOISONNEMENT AU MONOXYDE DE CARBONE

Le non-respect des consignes suivantes portant sur chacun des appareils raccordés au système d'évacuation mis en service pourrait entraîner l'empoisonnement au monoxyde de carbone ou la mort. Les consignes suivantes doivent être observées pour chaque appareil raccordé au système d'évacuation mis en service si les autres appareils raccordés au système ne sont pas en service:

1. Sceller toute ouverture non utilisée de la système d'évacuation;
2. S'assurer que la système d'évacuation présente des dimensions et une pente horizontale conformes à la norme ANSI Z223.1/NFPA 54, intitulée National Fuel Gas Code ou aux codes d'installation CSA-B149.1, ainsi qu'aux présentes instructions. S'assurer que la système d'évacuation n'est pas bloquée, restreinte, corrodée, qu'elle ne fuit pas et qu'elle ne présente aucun autre défaut potentiellement dangereux;
3. Dans la mesure du possible, fermer toutes les portes et fenêtres du bâtiment, et toutes les portes entre la pièce où se trouve l'appareil raccordé à la système d'évacuation et les autres pièces du bâtiment.
4. Fermer les registres des foyers;
5. Mettre en service les sècheuses et tout autre appareil qui n'est pas raccordé à la système d'évacuation. Faire fonctionner à régime maximal tout ventilateur d'évacuation, tel que les hottes de cuisinière et les ventilateurs de salles de bains. Ne pas mettre en service les ventilateurs d'été.
6. Respecter les instructions d'allumage. Mettre en service l'appareil à l'essai. Régler le thermostat de manière à ce que l'appareil fonctionne sans interruption;
7. Vérifier s'il y a débordement à l'orifice d'évacuation du coupe tirage des appareils dotés d'un coupe tirage 5 minutes après l'allumage du brûleur principal. Utiliser la flamme d'une allumette ou d'une chandelle.
8. Si l'on constate, au cours de l'un des essais qui précèdent, que l'évacuation est déficiente, corriger le système d'évacuation conformément à la norm ANSI Z223.1/NFPA 54, National Fuel Gas Code, et (ou) aux codes d'installation CSA B149.1.
9. Après avoir déterminé que tous les appareils raccordés à la système d'évacuation évacuent correctement tel que prescrit ci-dessus, rouvrir les portes et les fenêtres et remettre les ventilateurs d'évacuation, les registres de foyers et tout autre appareil fonctionnant au gaz à leur état de fonctionnement initial.

Important Information

WARNING:

Furnace installation using methods other than those described in the following sections must comply with the National Fuel Gas Code (NFGC) and all applicable local codes.

WARNING:

Upon completion of the furnace installation, carefully inspect the entire flue system both inside and outside the furnace to assure it is properly sealed. Leaks in the flue system can result in serious personal injury or death due to exposure of flue products, including carbon monoxide.

WARNING:

This furnace must not be vented with other appliances, even if that appliance is of the condensing type. This includes water heaters of any efficiency. Common venting can result in severe corrosion of other appliances or their venting and can allow combustion gases to escape through such appliances or vents. Do not vent the furnace to a fireplace chimney or building chase.

- This furnace must be vented in compliance with the current revision of the National Fuel Gas Code (ANSI-Z223.1/NFPA54). Instructions for determining the adequacy of combustion air for an installation can be found in the current revision of the NFGC (ANSI Z223.1 / NFPA54). **Consult local codes for special requirements.** These requirements are for US installations as found in the NFGC.
- The requirements in Canada (B149.1) are structured differently. In Canada, venting shall conform to the requirements of the current (CAN/CGA B149.1 or .2) installation codes. **Consult local codes for special requirements.**

Category IV Appliances

This furnace is classified as a Category IV appliance, which requires special venting materials and installation procedures. Category IV appliances operate with positive vent pressure and requires thoroughly sealed vent systems. They also produce liquid condensate, which is slightly acidic and can cause severe corrosion of ordinary venting materials. Furnace operation can be adversely affected by restrictive vent and combustion air piping.

Direct Vent Installation

This condensing furnace is certified for installation as a Direct Vent (2-pipe) appliance. Direct Vent (2-pipe) furnaces draw combustion air directly from the outdoors and then vent the combustion products back outside, isolating the entire system from the indoor space. It is important to make sure that the whole system is sealed and clearances to combustibles are maintained regardless of the installation being in a confined or unconfined space. This section specifies installation requirements for Direct Vent (2-pipe) piping. [Table 2, \(page 8\)](#) contains the length of vent and combustion air piping for this type of installation.

Provisions must be made during the installation of this furnace that provide an adequate supply of fresh air for combustion and ventilation. The combustion air from the outside needs to be clear of chemicals that can cause corrosion. The inlet pipe should not be placed near corrosive chemicals such as those listed on [page 5](#).

Air openings on top of the furnace and openings in closet doors or walls must never be restricted. If the furnace is operated without adequate air for combustion, the flame roll-out switch will open, turning off the gas supply to the burners. **This safety device is a manually reset switch. DO NOT install jumper wires across these switches to defeat their function or reset a switch without identifying and correcting the fault condition.** If a switch must be replaced, use only the correct sized part specified in the Replacement Parts List provided online.

Vent Pipe Length & Diameter

For proper furnace operation, the combustion air and vent piping must not be excessively restrictive.

- The venting system should be designed to have the minimum number of elbows or turns.
- All horizontal runs must slope upwards from the furnace at 1/4 inch minimum per running foot of vent.
- Transition to the final vent diameter should be done as close to the furnace outlet as practical.
- Always use the same size or a larger pipe for combustion air that is used for the exhaust vent.

[Table 2](#) indicates the maximum allowable pipe length for a furnace of known input rate, when installed with piping of selected diameter and number of elbows. To use the table, the furnace input rate, the centerline length and the number of elbows on each pipe must be known.

When estimating the length of vent runs, consideration must be made to the effect of elbows and other fittings. This is conveniently handled using the idea of “equivalent length”. This means the fittings are assigned a linear length that accounts for the pressure drop they will cause. For example: a 3” diameter, long radius elbow is worth the equivalent of 3.5 feet of linear run.

The equivalent lengths of tees and various elbows are listed in [Table 2](#). Measure the linear length of your vent run and then add in the equivalent length of each fitting. The total length, including the equivalent fitting lengths, must be less than the maximum length specified in the table.

MAXIMUM DIRECT VENT, DUAL PIPE LENGTH (FT.)		
M7RL INPUTS (BTU)	INLET / OUTLET 2" DIAMETER	INLET / OUTLET 3" DIAMETER
45,000	30	60
60,000	30	60
72,000	30	60

†NOTES:

1. Subtract 2.5 ft. for each additional 2 inch long radius elbow, subtract 5ft for each additional 2" short radiious elbow, subtract 3.5 ft. for each additional 3 inch long radius elbow, and 7 ft. for each additional 3 inch short radius elbow.
2. Two 45 degree elbows are equivalent to one 90 degree elbow.
3. This table applies for elevations from sea level to 2,000 ft. For higher elevations, decrease pipe lengths by 8% per 1,000 ft of altitude.

Table 2. Vent Pipe Lengths

Condensing furnace combustion products have very little buoyancy, so [Table 2](#) is to be used without consideration of any vertical rise in the piping.

Vent Pipe Material

Vent and combustion air pipe and fittings must be one of the following materials in the list and must conform to the indicated ANSI/ASTM standards.

MATERIALS	STANDARDS
SCHEDULE 40PVC.....	D1785
PVC-DWV.....	D2665
SDR-21 & SDR-26.....	D2241
ABS-DWV.....	D2661
SCHEDULE 40 ABS.....	F628
FOAM / CELLULAR CORE PVC.....	F891

When joining PVC to PVC, use cement that conforms to ASTM standard D2564. PVC primer must meet standard ASTM F656. When joining ABS to ABS, use cement that conforms to ASTM standard D2235. When joining PVC to ABS, use cement as specified in procedure from ASTM standard D3138.

In Canada, all plastic vent pipes and fittings including any cement, cleaners, or primers must be certified as a system to ULC S636. However this requirement does not apply to the finish flanges or piping internal to the furnace.

Vent Pipe Installation

⚠ CAUTION:

Combustion air must not be drawn from a corrosive atmosphere.

This furnace has been certified for installation with zero clearance between vent piping and combustibile surfaces. However, it is good practice to allow space for convenience in installation and service.

- In the absence of local codes, the location of any combustion air inlet relative to any vent terminal must be at least 8 inches. This includes installations involving more than one furnace.

- The quality of outdoor air must also be considered. Be sure that the combustion air intake is not located near a source of solvent fumes or other chemicals which can cause corrosion of the furnace combustion system. (See [page 5](#) for a sample list of substances).
- Route piping as direct as possible between the furnace and the outdoors. Longer vent runs require larger diameters. Vent piping must be sloped upwards 1/4" per foot in the direction from the furnace to the terminal. This ensures that any condensate flows back to the condensate disposal system.
- When a 2-pipe system is used, the combustion air intake and the vent exhaust must be located in the same atmospheric pressure zone. This means both pipes must exit the building through the same portion of exterior wall or roof as shown in [Figure 1](#), [Figure 2](#) & [Figure 4 \(page 9\)](#) and [Figure 29 \(page 38\)](#).
- Piping must be mechanically supported so that its weight does not bear on the furnace. Pipe supports must be installed a minimum of every five feet along the vent run to ensure no displacement after installation. Supports may be at shorter intervals if necessary to ensure that there are no sagging sections that can trap condensate. It is recommended to install couplings ([Figure 29](#)) along the vent pipe, on either side of the exterior wall. Couplings may be required by local code.
- If breakable connections are required in the combustion air inlet pipe (if present) and exhaust vent piping, then straight neoprene couplings for 3" piping with hose clamps can be used. These couplings can be ordered through your local furnace distributor. To install a coupling:
 1. Slide the rubber coupling over the end of the pipe that is attached to the furnace and secure it with one of the hose clamps.
 2. Slide the other end of the rubber coupling onto the other pipe from the vent.
 3. Secure the coupling with the second hose clamp, ensuring that the connection is tight and leak free.

Outdoor Terminations - Horizontal Venting

- Vent and combustion air intake terminations shall be installed as shown in [Figure 1](#), [Figure 2](#), [Figure 3](#), & [Figure 4](#) and in accordance with these instructions:
- Vent termination clearances must be consistent with the NFGC, ANSI 2223.1/NFPA 54 and/or the CSA B149.1, Natural Gas and Propane Installation Code. [Table 14, \(page 37\)](#) lists the necessary distances from the vent termination to windows and building air intakes.
- Vent and combustion air intake terminations must be located to ensure proper furnace operation and conformance to applicable codes. A vent terminal must be located at least 3 feet above any forced air inlet located within 10 feet. This does not apply to the combustion air inlet of a direct vent (two pipe) appliance. In Canada, CSA B149.1 takes precedence over these instructions. See [Table 14](#).
- All minimum clearances ([Figure 2](#)) must be maintained to protect building materials from degradation by flue gases.
- For optimal performance, vent the furnace through a wall that experiences the least exposure to winter winds.

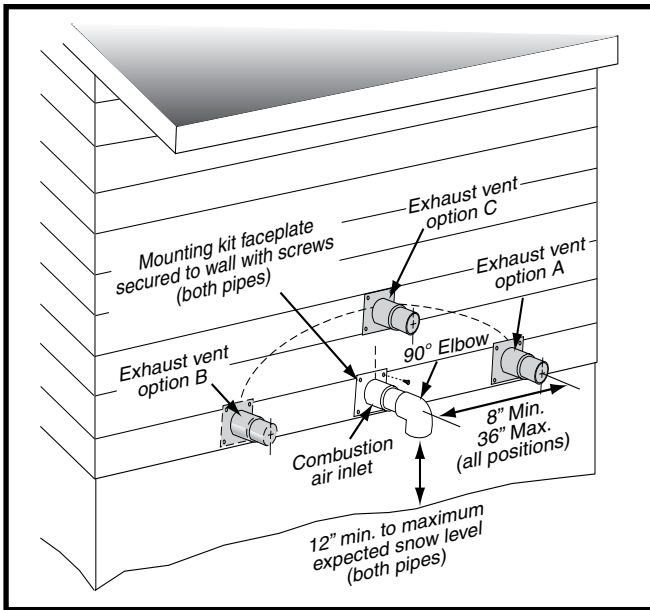

Figure 1. Inlet & Exhaust Pipe Clearances

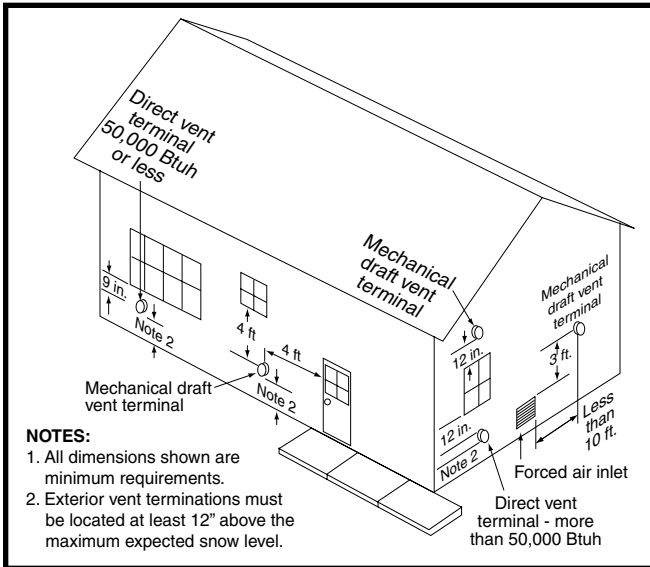

Figure 2. Vent Locations

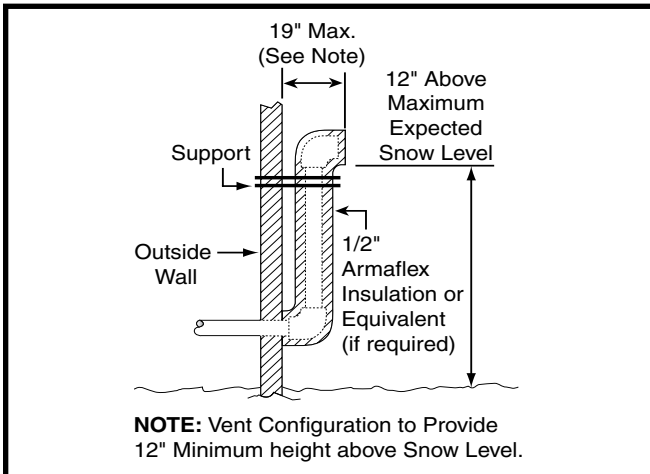

Figure 3. Alternate Horizontal Vent Installation

- The vent termination shall be located at least 3 ft. horizontally from any electric meter, gas meter, regulator and any relief equipment. These distances apply ONLY to U.S. installations. In Canada, CSA B149.1 takes precedence over these instructions.
- Do not install the vent terminal such that exhaust is directed into window wells, stairwells, under decks or into alcoves or similar recessed areas, and do not terminate above any public walkways.
- If venting horizontally, side wall vent kits are available according to the pipe diameter size of the installation. For 3 inch pipe, use kit #904347. Faceplate kit #902375 is also available for 3 inch horizontal venting. **Please follow the instructions provided with the kits.**
- Concentric vent kits are available for both 2" and 3" applications. Each size has one that meets UL 1738 and one that meets ULC S636. Refer to the technical sales literature for kit numbers.
- When the vent pipe must exit an exterior wall close to the grade or expected snow level where it is not possible to obtain clearances shown in [Figure 1](#), a riser may be provided as shown in [Figure 3](#). Insulation is required to prevent freezing of this section of pipe. See [Table 3, \(page 10\)](#) for vent freezing protection.

Outdoor Terminations - Vertical Venting

Termination spacing requirements from the roof and from each other are shown in [Figure 4](#). The roof penetration must be properly flashed and waterproofed with a plumbing roof boot or equivalent flashing. Vent and combustion air piping may be installed in an existing chimney which is not in use provided that:

- Both the exhaust vent and air intake run the length of the chimney.
- The top of the chimney is sealed and weatherproofed.
- The termination clearances shown in [Figure 4](#) are maintained.
- No other gas fired or fuel-burning equipment is vented through the chimney.

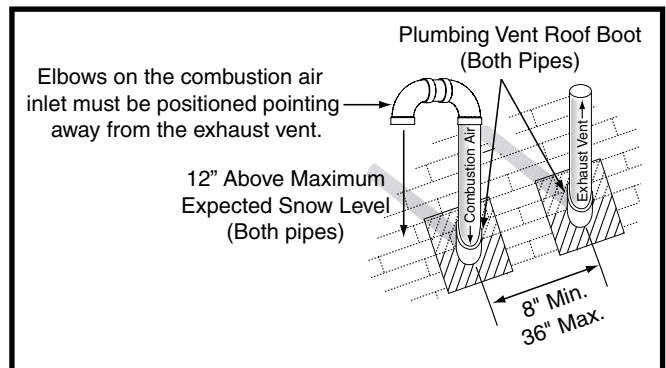

Figure 4. Vertical Vent Termination

Vent Freezing Protection

CAUTION:

When the vent pipe is exposed to temperatures below freezing (i.e., when it passes through unheated spaces, chimneys, etc.) the pipe must be insulated with 1/2 inch thick sponge rubber insulation, Armaflex-type insulation or equivalent. Insulating pipe is important to avoid condensate icing.

- [Table 3](#) lists the maximum length of flue pipe that can travel through an unconditioned space or an exterior space. The total vent length must not exceed the lengths noted in the table. For Canadian installations, please refer to the Canadian Installation Code (CAN/CGA-B149.1 or 2) and/or local codes.
- For extremely cold climates or for conditions of short furnace cycles (i.e. set back thermostat conditions) the last 18 inches of vent pipe can be reduced. It is acceptable to reduce from 3" to 2-1/2" or, 3" to 2" if the total vent length is at least 15 feet in length, and the vent length is within the parameters specified in [Table 2, \(page 8\)](#). The restriction should be counted as 3 equivalent feet. Smaller vent pipes are less susceptible to freezing, but must not be excessively restrictive.
- To prevent debris or creatures from entering the combustion system, a protective screen may be installed over the combustion air intake opening. The screens hole size must be large enough to prevent air restriction.

WINTER DESIGN TEMPERATURE	MAXIMUM FLUE PIPE LENGTH (FEET) IN UNCONDITIONED & EXTERIOR SPACES	
	WITHOUT INSULATION	WITH INSULATION*
20	45	70
0	20	70
-20	10	60

*NOTE: Insulation thickness greater than 3/8 inch, based on an R value of 3.5 (ft x F x hr) / (BTU x in.)

Table 3. Vent Protection

Existing Installations

When an existing furnace is removed from a vent system serving other appliances, the existing vent system may not be sized properly to vent the remaining appliances (example: water heater). An improperly sized venting system can result in the formation of condensate, leakage, or spillage. The existing vent system should be checked to make sure it is in compliance with NFGC and must be brought into compliance before installing the furnace.

NOTE: If replacing an existing furnace, it is possible you will encounter an existing plastic venting system that is subject to a Consumer Product Safety Commission recall. The pipes involved in the recall are High Temperature Plastic Vent (HTPV). **If your venting system contains these pipes DO NOT reuse this venting system!** This recall does not apply to other plastic vent pipes, such as white PVC or CPVC. Check for details on the CPSC website or call their toll-free number (800) 758-3688.

Ventilaire III or IV Air Quality Package

The Ventilaire air quality accessory packages are available to meet the ventilation requirements as outlined in H.U.D. Standard Part 3280.103 (b) (2). These packages introduce outdoor air into the living space during furnace blower operation. The VentilAire IV also serves to exhaust moist and/or hot air from the attic space. See [Figure 5](#) for typical installation. Complete installation instructions are supplied with each air quality package.

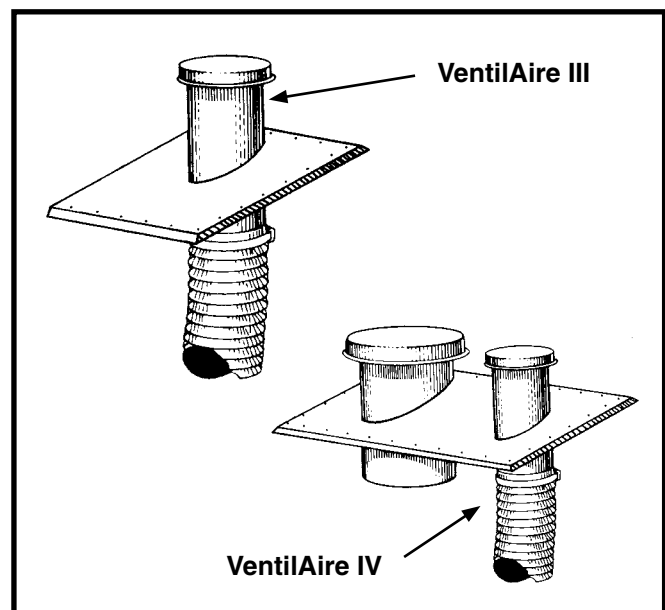

Figure 5. VentilAire III & IV

CIRCULATING AIR REQUIREMENTS

WARNING:

Do not allow combustion products to enter the circulating air supply. Failure to prevent the circulation of combustion products into the living space can create potentially hazardous conditions including carbon monoxide poisoning that could result in personal injury or death.

All supply ducts must be secured to the furnace with sheet metal screws and adequately sealed. When supply air is provided through the bottom of the unit, the joint between the furnace and the plenum must be air tight.

The surface that the furnace is mounted on must provide sound physical support of the furnace with no gaps, cracks or sagging between the furnace and the floor or platform.

Supply air ducts must not be connected to any other heat producing device such as a fireplace insert, stove, etc. This may result in fire, explosion, carbon monoxide poisoning, personal injury, or property damage.

Plenums & Air Ducts

This unit is designed only for use with a bottom supply duct and must be installed in accordance with the standards of the National Fire Protection Association Standard for Installation of Air Conditioning Systems (NFPA 90A), Standard for Installation of Residence Type Warm Air Heating and Air Conditioning Systems (NFPA 90B), and all applicable local codes. NFPA publications are available by writing to: National Fire Protection Association, Batterymarch Park, Quincy, ME 02269 or go to www.NFPA.org on the web.

- Design the air ducts according to methods described by the Air Conditioning Contractors of America (ACCA).
- Air ducts must be aluminum, tin plate, galvanized sheet steel, or other approved materials for outlet or return air ducts. Snap-Lock or Pittsburgh-Lock seams are preferred. All other types of seams must be made tight to prevent leakage.
- It is good practice to seal all connections and joints with industrial grade sealing tape or liquid sealant. Requirements for sealing ducts vary from region to region. Consult with local codes for requirements specific to your area.
- Gas piping must not run in or through any of the air duct system.
- Hollow spaces used as ducts or plenums for environmental air may contain mineral-insulated metal sheathed cable, aluminum sheathed cable, electrical metallic tubing, rigid metal conduit, flexible metal conduit (not to exceed 4 ft), or metal-clad cables. Wiring materials, fixtures, are to be suitable for the expected ambient temperatures to which they will be subjected.

Wiring materials located in the return duct system shall conform to Articles 300-22 of the National Electrical Code (NFPA-70).

- All duct work passing through unconditioned space must be properly insulated to minimize duct losses and prevent condensation. Use insulation with an outer vapor barrier. Refer to local codes for insulation material requirements
- Air conditioning systems may require more duct register and open louver area to obtain necessary airflow..
- Noncombustible pans having one inch upturned flanges are located beneath openings in a floor return duct system.

Supply Air Connections

- For proper air distribution, the supply duct system must be designed so that the static pressure measured external to the furnace does not exceed the listed static pressure shown on the furnace rating plate. The supply air must be delivered to the heated space by duct(s) secured to the furnace casing, running full length and without interruption.
- Duct system must be designed so that no supply registers are located in duct system directly below the furnace.
- Location, size, and number of registers should be selected on the basis of best air distribution and floor plan of the home. Three typical distribution systems are shown in [Figure 6](#).

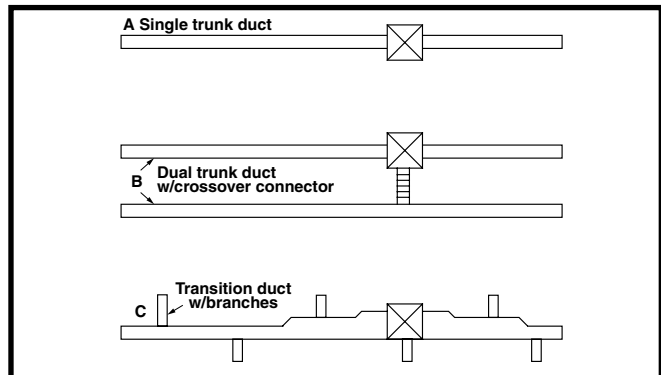

Figure 6. Typical Supply Duct Systems

Return Air Connections

- M7 furnaces with model numbers ending in AW or BW are factory configured for the return air to flow through the front louvered door. The return air may also be attached to either side of the furnace cabinet using a field installed kit (PN 904003). The location and size of the side and top return air connections are shown in [Figure 24 \(page 30\)](#) & [Figure 25 \(page 31\)](#). The filter size for the side return air is 20" x 20" x 1".
- Model numbers ending in AWT & BWT are factory configured for the return air to enter the top of the furnace. See [Figure 26 \(page 32\)](#) & [Figure 27 \(page 33\)](#).
NOTE: For top return installations, an external or in-wall filter mount can be used. The factory installed filter should be removed and the return duct should be sized to provide adequate airflow.

- For floor return systems, the manufactured housing manufacturer or installer shall affix a prominent marking on or near the appliance where it is easily read when the closet door is open. The marking shall read:

CAUTION, HAZARD OF ASPHYXIATION. DO NOT COVER OR RESTRICT FLOOR RETURN AIR OPENING.

- Return air openings should not be located to draw air directly from a bathroom.
- Materials located in the return duct system shall have a flame spread classification of 200 or less.
- The total free area of the openings in the floor or the ceiling registers serving the return air duct system must not be not less than 352 in² (2,270 cm²). At least one register should be located where it is not likely to be covered by carpeting, boxes and other objects.

Closest & Alcove Installations

WARNING:

Failure to comply with the the following instructions may result in fire, asphyxiation or carbon monoxide poisoning.

For proper air circulation, closet installations require a return air grill installed in the door or side wall that exchanges with the living area of the home. A partially louvered door may also be used across the opening. Grilles placed in a side wall require a 6" clearance from the wall to the furnace so that the air may enter the front grille of the furnace. All return air systems, including the floor and ceiling systems, must meet the following conditions:

- The return air opening, regardless of its location in the closet, must not be smaller than size specified on unit data label. If located in the floor, the opening must be provided with a means of preventing its inadvertent closure by flat object(s) placed over the opening.
- The cross-sectional area of the return duct system (in floor or ceiling) leading into the closet must not be less than 235 in² (1,516 cm²).

CAUTION:

HAZARD OF ASPHYXIATION: Negative pressure inside the closet, with closet door closed and the furnace blower operating on high speed, shall be no more negative than minus 0.05 inch water column.

- Test the negative pressure in the closet with the air-circulating fan operating at high speed and the closet closed. The negative pressure in the closet must not be less than minus 0.05 inches water column with the closet door closed and the fan operating at high speed. The negative pressure is to be no more negative than minus 0.05" water column as this indicates a dirty filter or a restricted return air system.

- For closet installation with less than 6" front clearance, but not less than 1", a louvered door must be used having a minimum 250 in² (1,613 cm²) free area opening directly in line with openings in the furnace door. For 1" clearance from furnace, use a fully louvered door with at least 400 in² (2,580 cm²) of free airflow area.

Furnace Filter

WARNING:

Never operate the furnace without a filter in place. Accumulating dust in the return air can build up on internal components, resulting in loss of efficiency, equipment damage, and possible fire.

- M7RL furnaces with AW or BW suffixes are supplied with a single reusable air filter when shipped from the factory. Accessing the filter does not require tools and can be easily removed from the inside of the access door. The filter is secured to the door with a retaining bracket.
- M7RL furnaces with AWT & BWT suffixes are shipped with a non-reusable single 18"x18"x1" air filter from the factory. Accessing the filter does not require tools and can be easily removed from inside the blower compartment. The filter is secured with a U-shaped retaining bracket. It is recommended that the filter be cleaned or replaced monthly. Newly built or recently renovated homes may require more frequent changing until the construction dust has minimized.
 1. Slide the standard 18"x18"x1" filter (P/N 669779) into the space between the combustion air pipe and the blower assembly. See [Figure 7 \(page 13\)](#). **NOTE:** Make sure the airflow arrows on the filter point towards the blower assembly.
 2. Push the filter to the rear of the furnace cabinet and angle it up over the blower. Make sure the filter is pushed back as far as possible.
 3. Position the filter retainer under the filter and insert the stepped ends into the 0.25 holes in the rear of the furnace. **NOTE:** The stepped ends should be facing upwards in the holes.
 4. Evenly align the filter over the opening in the top of the furnace cabinet and position the other end of filter retainer up over the flange in the furnace's top panel. **NOTE:** To properly secure the filter, make sure the filter retainer is properly positioned in the top panel of the furnace. There should be no visible air gaps. The retainer may slide left or right slightly, but must not have any movement between the front and rear. See [Figure 7](#).
- Replacement filters are available at most local retailers. Inspect filters frequently and replace when necessary with filter of same dimensional size. Filters designed to remove smaller particles such as pollen, may require additional maintenance.

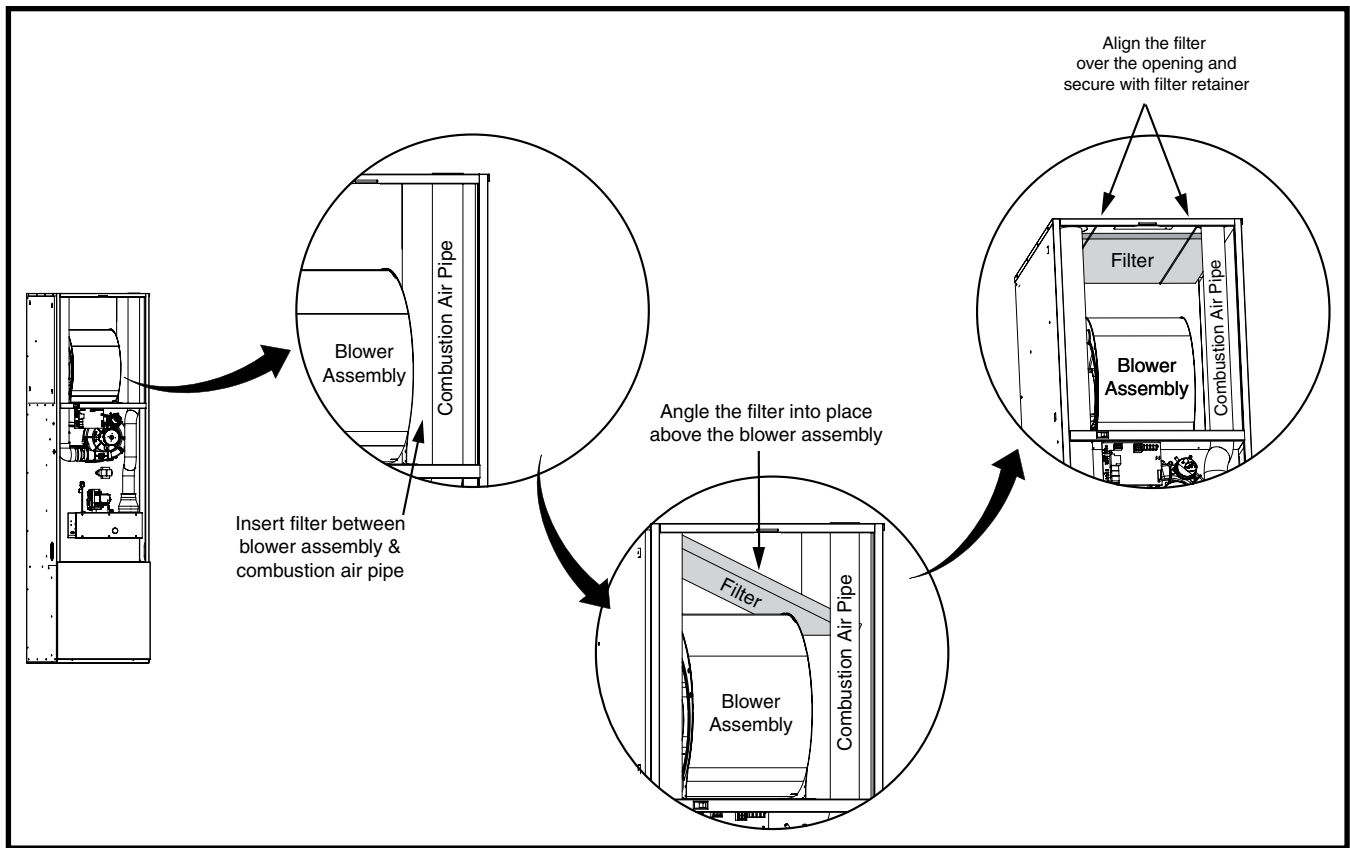

Figure 7. Filter Installation

Dampers

An automated shut off damper is required when the home is air conditioned by a self-contained unit. A damper is required to prevent chilled air from flowing over the furnace heat exchanger. This damper is designed to fit in the feeder duct cavity, directly under the furnace. For proper installation, refer to the instructions provided with the damper. See replacement parts list provided online.

Acoustical Treatments

Damping ducts, flexible vibration isolators, or pleated media-style filters on the return air inlet of the furnace may be used to reduce the transmission of equipment noise emanating from the furnace. These treatments can produce a quieter installation, particularly in the heated space. However, they can increase the pressure drop in the duct system. Care must be taken to maintain the proper maximum pressure rise across the furnace, temperature rise and flow rate. This may mean increasing the duct size and/or reducing the blower speed. These treatments must be constructed and installed in accordance with NFPA and SMACNA construction standards. Consult with local codes for special requirements. For best sound performance, install all the needed gaskets and grommets around penetrations into the furnace, such as for electrical wiring.

FURNACE INSTALLATION

NOTE: These Installation procedures are suggested for typical furnace installations. Since each installation is different, the sequence of instructions may differ from the actual installation. Only qualified HVAC technicians should install this furnace.

The installer must be familiar with and comply with all codes and regulations applicable to the installation of these heating appliances and related equipment. In the absence of local codes, the installation must be in accordance with the current provisions of one or more of the following standards.

- Federal Manufactured Home Constructions & Safety Standard (H.U.D. Title 24, Part 3280.707[a][2])
- American National Standard (ANSI-119.2/NFPA-501C) for all recreational vehicle installations.
- American National Standard (ANSI-Z223.1/NFPA-54) and/or CAN/CSA B149 for all gas-fired furnace models.
- American National Standard (ANSI-Z95.1/NFPA-31) and/or CSA B139 for all oil-fired furnace models.
- American National Standard (NFPA-70) and/or CSA 22.1 Canadian Electric Code Part 1 for all electrical field wiring.
- Units have been researched under standards UL 307A & B, UL727-1999, ANSI Z21.47b/CSA 2.3b-2008, and CSA B140.10.

About The Furnace

The M7RL furnace is designed only for indoor installations and can be readily connected to the high static duct system of a home. Units are approved for single/multistory residential or mobile/modular/manufactured structures in freestanding/closet/alcove downflow only configurations.

This appliance will provide many years of safe and dependable comfort, providing it is properly installed and maintained. Abuse, improper use, and/or improper maintenance can shorten the life of the appliance and create unsafe hazards. Please read all instructions before installing the unit.

Approved installation, operation, and maintenance of this appliance must be in accordance with the listed specifications contained in these instructions and other documents supplied with the furnace and/or optional air conditioning equipment. Unless it is noted differently in this manual, only use factory authorized kits and accessories on this appliance. Refer to local authorities having jurisdiction for further information.

Before You Install this Furnace

- ✓ This equipment is securely packaged at the time of shipment and upon arrival should be carefully inspected for damage prior to installing the equipment at the job site. Claims for damage (apparent or concealed) should be filed immediately with the carrier.
- ✓ Check the electrical supply and verify the power supply is adequate for unit operation. The system must be wired and provided with circuit protection in accordance with local building codes. If there is any question concerning

- the power supply, contact the local power company.
- ✓ Verify the air delivery of the furnace is adequate to handle the static pressure drop of the coil, filter, and duct work.

Locating the Unit

- The dimensions of the room or alcove must be able to accommodate the overall size of the unit and required clearances to combustible materials listed in Table 1 (page 5). Access for positioning and servicing must also be considered when locating the unit. To determine the required clearances needed for installation and combustible materials, refer to [Figure 24 \(page 30\)](#), [Figure 25 \(page 31\)](#), [Figure 26 \(page 32\)](#) and [Figure 27 \(page 33\)](#) for overall dimensions.
 - The furnace must be installed on a solid surface and must be level front-to-back and side-to-side at installation. The surface that the furnace is mounted on must provide sound physical support of the unit.
 - The furnace should be installed as close to the center of the air distribution system as possible and attached to a properly installed duct system. **Do not use the back of the furnace for return air.** See [pages 11 - 11](#) for circulating requirements.
 - The furnace must be installed so that all electrical components are protected from water.
 - The plenum attached to the A/C coil box and ductwork within 3 ft. of the furnace must be installed so that surfaces are at least 1/4" from combustible construction.
 - When installed in a residential garage, the furnace must be positioned so the burners and the source of the ignition are located no less than 18 inches above the floor and protected from physical damage by vehicles.
 - This furnace is certified for use on wood flooring or supports, but must not be installed directly on carpeting, tile, or any combustible material other than wood flooring.
- NOTE:** The furnace may be installed on combustible flooring when installed on a duct connector ([Figure 8](#)). This factory supplied accessory must be installed in the floor cavity and attached to the supply air duct before the downflow furnace is installed.
- The furnace must be installed upstream from a refrigeration system.

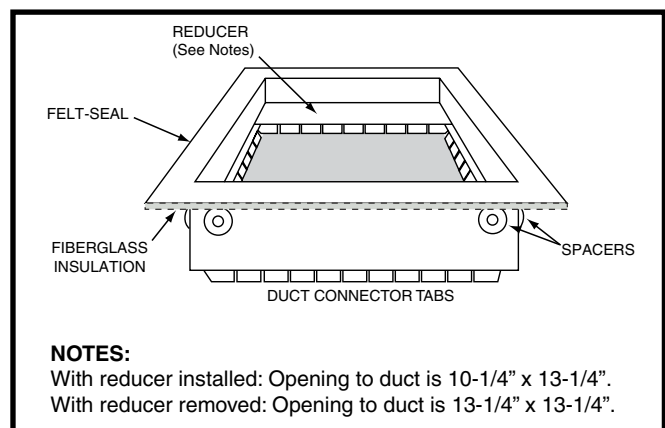

Figure 8. Duct Connector

IF FLOOR CAVITY ("X") IS:	DUCT CONNECTOR TYPE & PART NUMBER	
	FINGER TAB	SCREW DOWN
7/8" (22)	901987A	904008
2" (51)	901988A	904009
4-1/4" (108)	901989A	904010
6-1/4" (159)	901990A	904011
8-1/4" (210)	901991A	904012
10-1/4" (260)	901992A	904013
12-1/4" (311)	901993A	904014

NOTE: Dimensions shown as Inches (Millimeter)

Table 4. Duct Connector Sizes

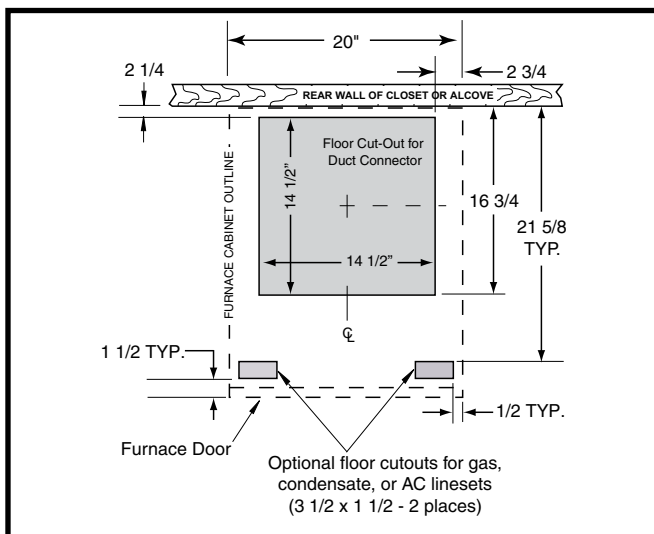

Figure 9. Floor Cutout Dimensions

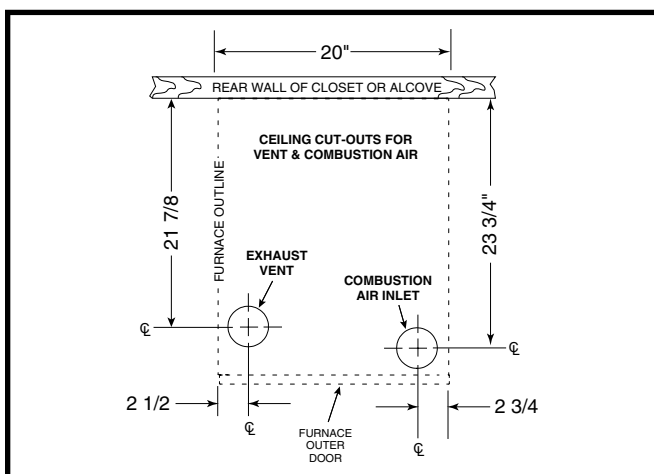

Figure 10. Ceiling Cut-Out Dimensions

Locating & Cutting Floor Openings

IMPORTANT NOTE:

Cut-outs in the floor, must be carefully located to avoid misalignment of the furnace.

To locate standard ducts, see [Figure 9](#). For round ducts, see [Figure 10](#).

1. Measure from the rear wall or alcove and mark the centerline of the cut-out on the floor. Using the centerline as a starting point, draw the rest of the duct cut-out to the dimensions shown in [Figure 9](#).
2. Cut out the floor opening to within 1" of the actual cutout drawn.
3. Measure from the top of the floor down to the top of the supply air duct to obtain the depth of the floor cavity. **NOTE:** The depth of the floor cavity shown as "X" in Table 4 will determine the correct duct connector.
4. Determine which duct connector to use from the table.
5. Measure and drill gas hole and cut out for cooling coil (if applicable). See [Figure 9](#) or [Figure 10](#).

Locating & Cutting Ceiling Openings

IMPORTANT NOTE:

Cut-outs in the ceiling and roof must be carefully located to avoid misalignment of the furnace, combustion air piping, and vent piping. See Figure 10.

1. Measure from the rear wall or alcove and mark the centerlines of both cut-outs in the ceiling.
2. Using the centerlines as a starting point, draw the rest of the cut-outs to the dimensions shown in [Figure 10](#).
3. Cut out the ceiling openings.

Installing Finger Tabbed Duct Connectors

The standard duct connector is designed for use on ducts 12" in width. However ducts narrower than 12" may not allow sufficient clearances for this type of installation. For an alternate installation method, see [page 16](#).

1. Center the duct connector in the floor opening with bottom tabs resting on top of the supply air duct.
2. Mark the cut-out area on the supply air duct by tracing around the connector tabs of the duct connector.
3. Remove the duct connector and cut out the marked area of the supply air duct 1/16" larger the actual cutout drawn. See [Figure 11](#) (page 16).
4. Install the duct connector back in the floor opening with the bottom tabs extending into the supply air duct.
5. Install the mounting plate ([Figure 11](#)) under the back side of the duct connector. Align the screw holes in both components.
6. Secure the duct connector and the mounting plate to the wood floor with appropriate size screws.
7. Bend the connector tabs on the bottom of the duct connector upwards and as tight as possible against the supply air duct. See [Figure 11](#).
8. Seal all connections with industrial grade sealing tape or liquid sealant. **NOTE:** Requirements for sealing ductwork vary from region to region. Consult with local codes for requirements specific to your area.

Narrow Duct Attachment - Option 1

These alternate attachment methods may be used to install a furnace duct connector to narrow metal ductwork if insufficient clearances prevent the bending of the duct connector tabs at the side of the duct.

1. Select Option A or Option B in [Figure 12](#) and cut the top of the supply air duct. Remove metal flaps from the duct (shaded area) if Option A is selected.
2. Fold the duct flaps up to form an opening for the duct connector (applies to Options A or B).
3. Install the duct connector with the bottom tabs extending into the supply air duct.
4. Bend the tabs on the bottom of the duct connector upwards and as tight as possible against the removed ends of the supply air duct.
5. Form the duct flaps up against the side of the duct connector as tight as possible. See [Figure 12](#).
6. Secure the duct connector flaps to the supply air duct with staples (3 minimum) or if a 2x block/joist is not provided, use sheet metal screws (2 minimum).

NOTE: The duct connector tabs may be attached to the air duct with sheet metal screws or other suitable fasteners as long as the duct connector and the air duct are securely attached.

7. Seal all connections with industrial grade sealing tape or liquid sealant.

NOTE: Requirements for sealing ductwork vary from region to region. Consult with local codes for requirements specific to your area.

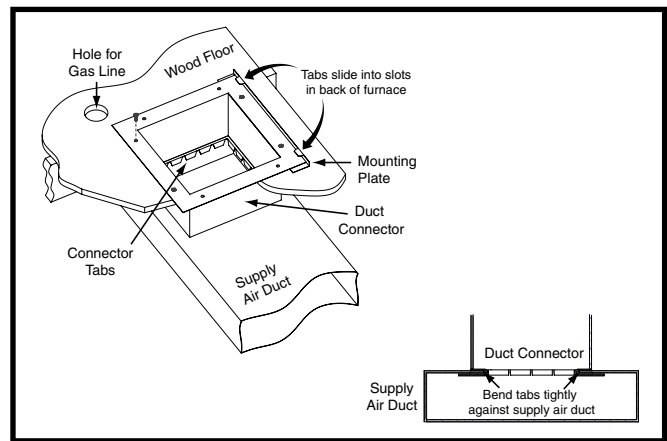

Figure 11. Finger Tabbed Duct Connector

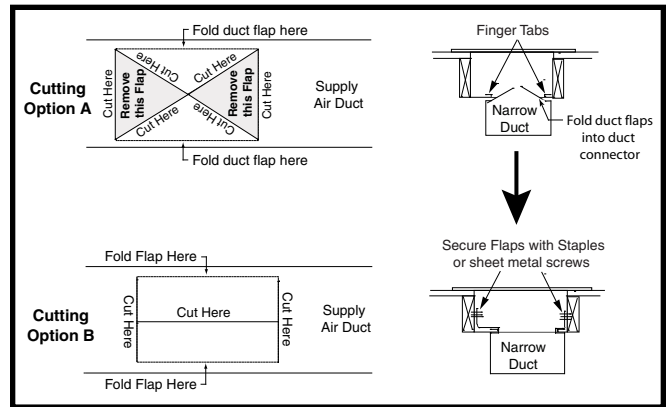

Figure 12. Narrow Air Ducts - Option 1

Narrow Duct Attachment - Option 2

These alternate attachment methods may be used to install a furnace duct connector to narrow metal ductwork if insufficient clearances prevent the bending of the duct connector tabs at the side of the duct.

1. Cut and remove the top of the supply air duct as shown in [Figure 13](#).
2. Install the duct connector with the bottom tabs extending into the supply air duct.
3. Bend the tabs on the bottom of the duct connector upwards and as tight as possible against the supply air duct ([Figure 13](#)).
4. Secure the duct connector tabs to the supply air duct with staples (3 minimum) or sheet metal screws (2 minimum).

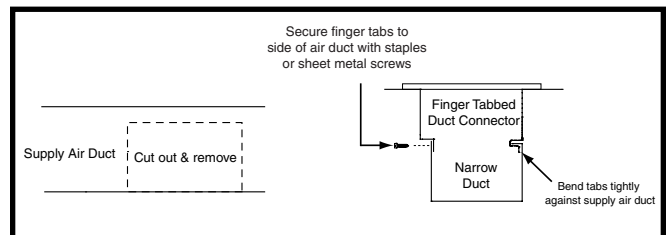

Figure 13. Narrow Ducts - Option 2

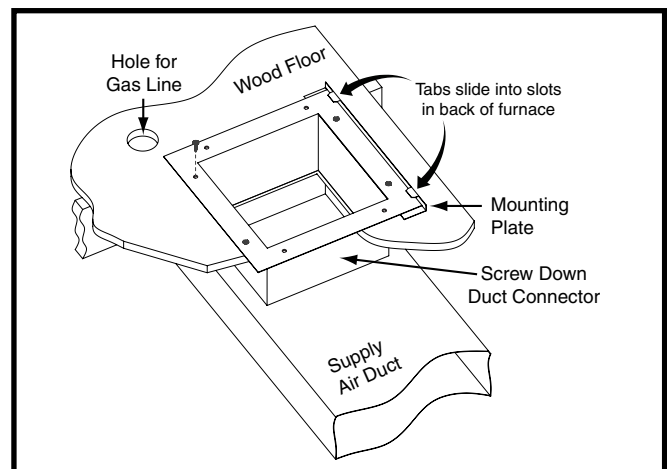

Figure 14. Screw-Down Duct Connector

Installing Screw-Down Duct Connectors

1. Apply a bead of caulking, mastic, or other approved sealant around bottom side of 1/2" flange and restrictor plate (when applicable).
2. Locate the screw down duct connector over the duct and carefully lower it into place.
3. Secure the duct connector to the floor using flat head screws or nails. **NOTE:** Make sure the duct connector flanges stay in contact with the duct.
4. Secure the plenum to the duct using sheet metal screws making sure a tight seal is made between the duct and the duct connector. **NOTE:** Additional screws may be added if required.
5. Cut away along edge of flange allowing the center to drop into the duct. **NOTE:** Remove section of duct with caution, as edges will be sharp.

Round Duct Connector Installation

1. Install and center the duct connector in the floor opening.
2. Install the mounting plate (Figure 15) under the back side of the duct connector. **NOTE:** Make sure the screw holes are aligned in both components.
3. Using appropriate size screws, secure the duct connector and the mounting plate to the wood floor.
4. Connect the round supply duct to the underside of the duct connector and secure them with field supplied sheet metal screws or appropriate clamps.
5. Seal all connections with industrial grade sealing tape or liquid sealant as required.

Requirements for sealing ductwork vary from region to region. Consult with local codes for requirements specific to your area.

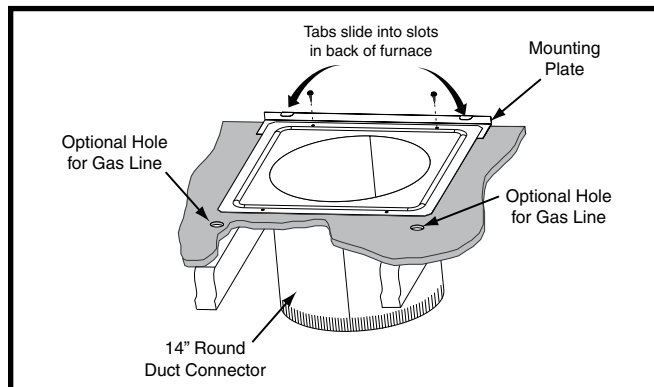

Figure 15. Round Duct Connector

Installing the Furnace

Sides and back of the furnace may be enclosed by wall framing such as in a closet or alcove. The dimensions of the room or alcove must be able to accommodate the overall size of the furnace and the installation clearances outlined on page 5 and Figure 1, Figure 2, Figure 3, & Figure 4 (page 9). The furnace shall be appropriately connected to the supply and return air distribution system as shown in Figure 24 (page 30), Figure 25 (page 31), Figure 26 (page 32), and Figure 27 (page 33).

1. Remove furnace outer door(s) and bottom fuel line knockout.
2. Place furnace onto duct connector and center with floor opening.
3. Slide onto mounting plate. (Bottom rear slots on furnace should engage with mounting plate tabs.)
4. Secure front with one (1) fastener at each corner (Figures 15 or 16).

NOTE: Additional fasteners may be used at rear, sides or through door frame, as desired, to secure furnace to closet or alcove framing.

Condensate Drainage

⚠ WARNING:

The condensate produced by the furnace must be drained. Do not connect a water supply to the drainage hose of the furnace.

⚠ CAUTION:

Do not install additional traps in the condensate drain.

- If the furnace is installed in an area where temperatures fall below freezing, special precautions must be made for insulating condensate drain lines that drain to the outdoors. If condensate freezes in the lines, this will cause improper operation or damage to the furnace. It is recommended that all drain lines on the outside of the residence be wrapped with an industry approved insulation or material allowed by local code.
- Before routing the drain tube out of the furnace, loosen the tube clamp and turn the tube so the preset 90° turn faces the intended direction of exit from the cabinet. Do not route the drain tube without rotating the tube first. This will kink the tube and prevent condensate from draining.
- Care should be taken to route the drain line away from the burner box. Drain lines resting on the burner box can become kinked or collapsed due to the heat from the burner box.
- The condensate drain may exit through the left or right slots in the bottom of the furnace (Figure 17). Make sure the flexible drain hose is not kinked.

- The condensate should drain from the plastic collector box as droplets or a small stream. If you notice the furnace has operated for more than 5 minutes without draining or the status lights on the control board indicate an open pressure switch as listed in [Table 7, \(page 29\)](#), follow the steps below.
1. Remove the collector box soft tube ([Figure 17](#)) and verify the exit from the collector box is clear of any debris or obstructions.
 2. Replace this tube and verify the fit to the header spout is air tight. Air will be drawn into the header if this connection is not tight.
 3. Check other tube connections along the drain system. Verify that all are air tight.

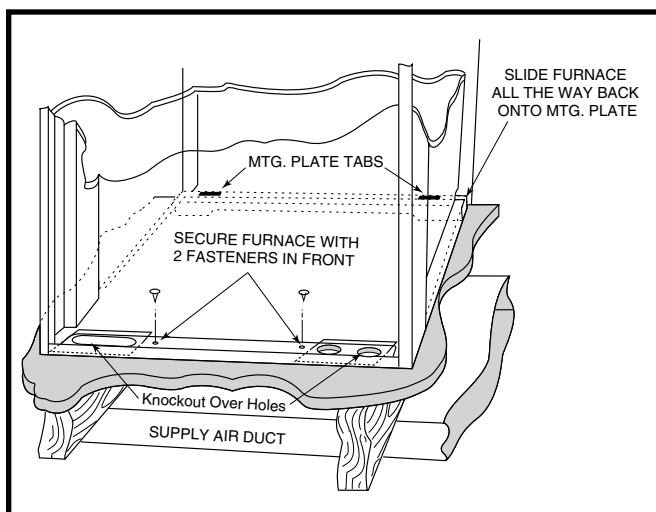

Figure 16. Cabinet Furnace on Supply Air Duct

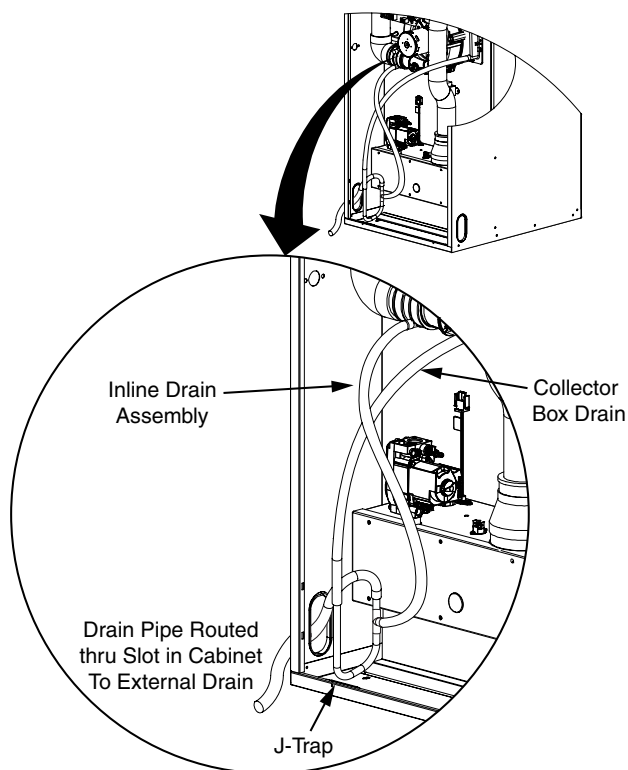

Figure 17. Condensate Drainage

GAS SUPPLY & PIPING

⚠ WARNING:

FIRE OR EXPLOSION HAZARD

- Failure to follow safety warnings exactly could result in serious injury or property damage.
- Installation and service must be performed by a qualified installer, service agency or the gas supplier.
- Do not store or use gasoline or other flammable vapors and liquids in the vicinity of this or any other appliance.

WHAT TO DO IF YOU SMELL GAS

- Do not try to light any appliance.
- Do not touch any electrical switch; do not use any phone in your building.
- Leave the building immediately.
- Immediately call your gas supplier from a neighbor's phone. Follow the gas supplier's instructions.
- If you cannot reach your gas supplier, call the fire department.

⚠ AVERTISSEMENT:

RISQUE D'INCENDIE OU D'EXPLOSION

- Le non-respect des avertissements de sécurité pourrait entraîner des blessures graves, la mort ou des dommages matériels.
- L'installation et l'entretien doivent être effectués par un installateur qualifié, un organisme de service ou le fournisseur de gaz.
- Ne pas entreposer ni utiliser de l'essence ni d'autres vapeurs ou liquides inflammables dans le voisinage de cet appareil, ni de tout autre appareil.

QUE FAIRE S'IL Y A UNE ODEUR DE GAZ

- Ne pas tenter d'allumer aucun appareil.
- Ne toucher à aucun interrupteur électrique; n'utiliser aucun téléphone dans le bâtiment.
- Évacuer l'immeuble immédiatement.
- Appeler immédiatement le fournisseur de gaz en employant le téléphone d'un voisin. Respecter à la lettre les instructions du fournisseur de gaz.
- Si personne ne répond, appeler le service des incendies.

- All gas piping must be installed in compliance with local codes and utility regulations. In the absence of local codes, the gas line installation must comply with the latest edition of the Federal Manufactured Home Construction & Safety Standard (H.U.D. Title 24, Part 3280.707[a][2]), NFGC (ANSI Z223.1) or (CAN/CGA B149.1 or .2) Installation Codes.
- Some local regulations require the installation of a manual main shut-off valve and ground joint union external to the furnace as shown in Figure 18. The shut-off valve should be readily accessible for service and/or emergency use. Consult the local utility or gas supplier for additional requirements regarding placement of the manual main gas shut-off.
- Per ANSI 21.47, A 1/8-inch NPT plugged tapping, accessible for test gauge connection, must be installed immediately upstream of the gas supply connection to the furnace external to the cabinet. If local codes allow the use of a flexible gas appliance connector, always use a new listed connector. Do not use a connector that has previously serviced another gas appliance.
- Gas piping must never run in or through air ducts, chimneys, gas vents, or elevator shafts.
- Compounds used on threaded joints of gas piping must be resistant to the actions of LP propane gas.
- The main gas valve and main power disconnect to the furnace must be properly labeled by the installer in case emergency shutdown is required.
- Flexible gas connectors are not recommended for this type of furnace but may be used if allowed by local jurisdiction. Only new flexible connectors may be used. Do not use a connector which has previously serviced another gas appliance.
- A drip leg should be installed in the vertical pipe run to the unit if not entering the furnace through the floor.

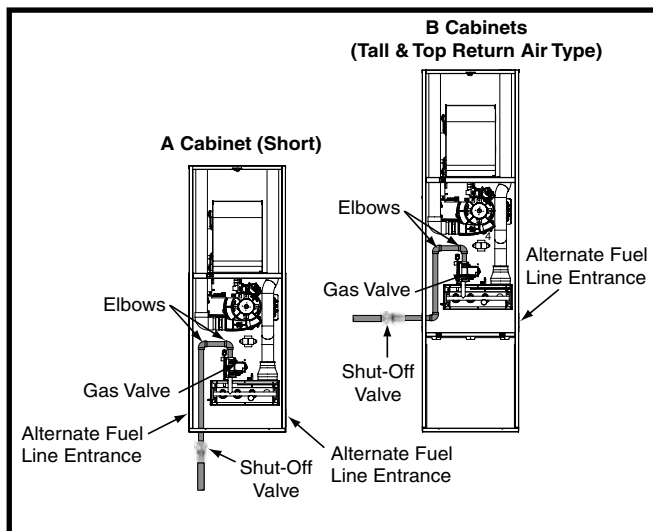

Figure 18. Typical Gas Connections

Table 9, (page 35) lists gas flow capacities for standard pipe sizes as a function of length in typical applications based on nominal pressure drop in the line.

The furnace is installed with a bottom gas entry. When connecting the gas supply, provide clearance between the gas supply line and the entry hole in the furnace casing to avoid unwanted noise and/or damage to the furnace. Typical gas hookups are shown in Figure 18.

Leak Check

⚠ WARNING:

FIRE OR EXPLOSION HAZARD

Failure to follow safety warnings exactly could result in serious injury or property damage.

Never test for gas leaks with an open flame. Use a commercially available soap solution made specifically for the detection of leaks to check all connections. A fire or explosion may result causing property damage, personal injury or loss of life.

⚠ AVERTISSEMENT:

RISQUE D'INCENDIE OU D'EXPLOSION

Le non-respect des avertissements de sécurité pourrait entraîner des blessures graves, la mort ou des dommages matériels.

Ne jamais utiliser une flamme nue pour vérifier la présence des fuites de gaz. Pour la vérification de tous les joints, utiliser plutôt une solution savonneuse commerciale fabriquée spécifiquement pour la détection des fuites de gaz. Un incendie ou une explosion peut entraîner des dommages matériels, des blessures ou la mort.

After the gas piping to the furnace is complete, all connections must be tested for gas leaks. This includes pipe connections at the main gas valve, emergency shutoff valve and flexible gas connectors (if applicable). The soap and water solution can be applied on each joint or union using a small paintbrush. If any bubbling is observed, the connection is not sealed adequately and must be retightened. Repeat the tightening and soap check process until bubbling ceases.

IMPORTANT NOTE:

When pressure testing gas supply lines at pressures greater than 1/2 psig (14 inch W.C.), the gas supply piping system must be disconnected from the furnace to prevent damage to the gas control valve. If the test pressure is less than or equal to 1/2 psig (14 inch W.C.), close the manual shut-off valve.

High Altitude Application

High altitude conversion with this furnace depends on the installation altitude and the heating value of the gas. Installation of this furnace at altitudes above 2,000 feet shall be in accordance with local codes, or in the absence of local codes, the National Fuel Gas Code, ANSI Z223.1/ NFPA 54 or National Standard of Canada, Natural Gas & Propane Installation Code CGA B149.1. Please consult your local code authority.

The installer must indicate the furnace has been converted to high altitude. This may be accomplished by marking the rating plate with a permanent marker.

WARNING:

The reduction of input rating necessary for high altitude installation may only be accomplished with factory supplied orifices. Do not attempt to drill out orifices in the field. Improperly drilled orifices may cause fire, explosion, carbon monoxide poisoning, personal injury or death.

The furnaces are shipped from the factory with orifices and gas regulator settings for natural gas operation at sea level altitudes. At 2000 feet, the NFGC requires that this appliance be derated 4% for each 1000 feet of altitude. For example, the input needs to be reduced 8% at 2,000 feet, 12% at 3,000 feet, etc. This deration is in reference to the input rate and gas heating value at sea level.

To derate the furnace requires knowing the heating value of the gas at the installation site. Heating values at particular job sites vary for two reasons:

1. The chemical mixture of the gas varies across regions and is expressed as the sea level heating value.
2. The heating value varies by altitude. For this reason, especially in high altitude areas, the local gas utility specifies the heating value at the residence's gas meter as the local value.

For added flexibility, two tables have been provided for natural gas installations with high or low heating values at sea level. [Table 12](#) & [Table 13](#), (page 36) contain the manifold pressure and orifice sizes to use at various altitudes. [Table 12](#) (HIGH) is for natural gas installations with a heating value of more than 1,000 Btu per cubic foot and [Table 13](#) (LOW) is for less than 1,000 Btu per cubic foot. To determine which table to use:

1. Consult the local utility for the local heating value at your installation site.
2. From [Table 11](#), (page 36), find your local heating value as supplied by the utility company. Follow down the column and stop at your altitude level.
3. If your sea level heating value is HIGH, use [Table 12](#) or if it's LOW, use [Table 13](#). See example.

After changing the orifices, it is required that you measure the gas input rate. This may be accomplished in the usual way, by clocking the gas meter and using the local gas heating value. See [Verifying & Adjusting the Input Rate](#) section (page 25).

IMPORTANT NOTE:

Observe the action of the burners to make sure there is no yellowing, lifting or flashback of the flame.

Installation Example

Elevation: 5,000 feet
Type of Gas: Natural Gas
Local Heating Value of Gas: 750

From [Table 11](#), find 750 and follow down the column, stop at the 5,000 feet row. The heating value listed is LOW. [Table 13](#) will be used to determine orifice size and manifold pressure.

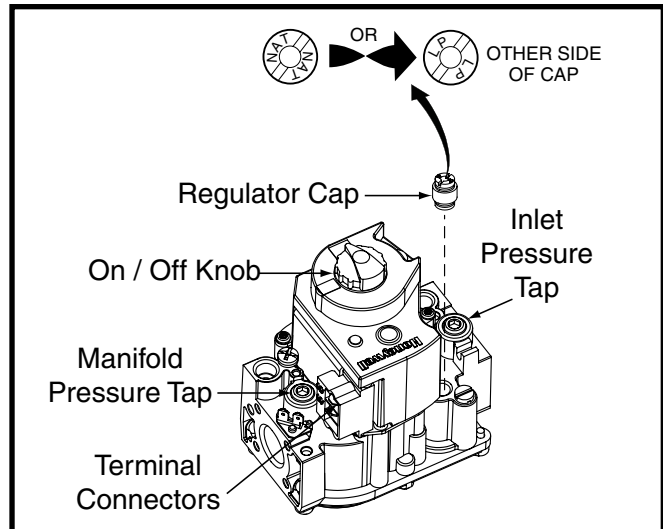

Figure 19. Gas Valve

Converting to LP/Propane Gas at Altitudes between 0 & 10,000 FT.

WARNING:

The furnace was shipped from the factory equipped to operate on natural gas. Conversion to LP / Propane gas must be performed by qualified service personnel using a factory supplied conversion kit. Failure to use the proper conversion kit can cause fire, explosion, property damage, carbon monoxide poisoning, personal injury, or death.

Converting single stage valves to LP/Propane requires the replacement of the burner orifices and flipping the regulator cap to the side marked LP. The end facing up should now read LP. See [Figure 19](#).

⚠ WARNING:

Shut off the gas supply at the manual gas shutoff valve, before disconnecting the electrical power. A fire or explosion may result causing property damage, personal injury or loss of life. Failure to follow the safety warnings exactly could result in serious injury, death or property damage.

⚠ WARNING:

To avoid electric shock, personal injury, or death, turn off the electric power at the disconnect or the main service panel before making any electrical connections.

⚠ WARNING:

The reduction of input rating necessary for high altitude installation may only be accomplished with factory supplied orifices. Do not attempt to drill out orifices in the field. Improperly drilled orifices may cause fire, explosion, carbon monoxide poisoning, personal injury or death.

Removing The Burner Orifices

1. Set the thermostat to the OFF position, or its lowest temperature setting.
2. Shut OFF the gas supply at the manual shutoff valve located outside of the appliance.
3. Turn off all electrical power to the appliance.
4. Remove the door from the burner box by removing 6 screws.
5. Turn the gas valve ON/OFF knob to the OFF position. See [Figure 19](#).
6. Remove the wires from the terminals of the gas valve.
7. Remove the supply gas piping from the gas valve inlet.
8. Carefully remove four screws securing the gas manifold assembly to the burner assembly. See [Figure 20](#).
9. Set the screws aside and remove the gas manifold assembly from the appliance.
10. Carefully remove the burner orifices from the gas manifold assembly.
11. Read the rating plate affixed to the appliance to determine its rated input (Btu/hr) and the size of the factory installed orifices.

IMPORTANT: Before installing an orifice, check the side or face of the orifice for the drill number to ensure that it is the appropriate size.

12. Install the appropriate LP/Propane gas burner orifices into the gas manifold assembly. **NOTE:** The orifices are included with the furnace. To prevent cross threading, hand tighten the orifices into the gas manifold assembly until snug, then tighten with a wrench.

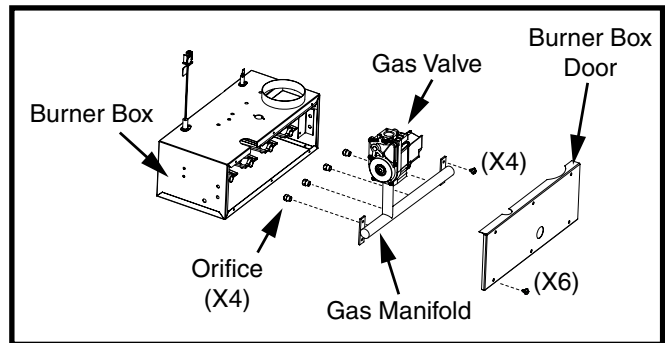

Figure 20. Orifice Removal

13. Unscrew the gas valve pressure regulator cap marked NAT. Invert the cap so LP faces up. Reinstall the cap and tighten until snug. Make sure LP is visible after conversion.

⚠ WARNING:

Do not use Teflon tape or pipe joint compound on the orifice threads. The hole in the orifice may become blocked and cause fire, explosion, property damage, carbon monoxide poisoning, personal injury, or death.

14. Reinstall the gas manifold assembly to the burner assembly with the 4 screws, that were removed earlier. **NOTE:** It is important that the center of the orifices are aligned with the center of the burners.
15. Reinstall the burner box door with the 6 screws that were removed earlier in step 4.
16. Reconnect the gas piping to the gas valve inlet.
17. Reconnect the wires to the gas valve terminals.

Gas Pressure Verification

Measuring the Supply Gas Pressure

1. Turn OFF the gas supply at the manual valve located on the outside of the unit.
2. Using a 3/16" Allen wrench, remove the plug from the inlet pressure tap (INLET side of gas valve). See [Figure 19 \(page 20\)](#).
3. Install an 1/8" NPT pipe thread fitting, that is compatible with a Manometer or similar pressure gauge.
4. Connect the Manometer or pressure gauge to the Inlet Pressure Tap.
5. Turn ON the main gas supply at the manual valve.
6. Check and adjust the incoming gas line pressure to 11.0-14.0 inches Water Column for LP/Propane gas.
7. Turn OFF the gas supply at the manual valve.
8. Disconnect the Manometer or pressure gauge.
9. Remove the NPT fitting and reinstall the INLET pressure tap plug. Hand tighten the plug first to prevent cross-threading. Tighten with 3/16 Allen wrench.

Lighting & Adjustment of the Appliance

WARNING:

FIRE OR EXPLOSION HAZARD

Failure to follow safety warnings exactly could result in serious injury or property damage.

Never test for gas leaks with an open flame. Use a commercially available soap solution made specifically for the detection of leaks to check all connections. A fire or explosion may result causing property damage, personal injury or loss of life.

1. Turn ON the manual gas valve, located on the outside of the unit to the ON position.
2. Check all gas connections for leaks with a soap and water solution. If the solution bubbles there is a gas leak which must be corrected.
3. Turn on the electrical power to the appliance.
4. Turn the gas valve ON/OFF knob to the ON position. See [Figure 19 \(page 20\)](#).
5. Set the thermostat to a point above room temperature to begin the heating cycle of the furnace.
6. Check that the furnace ignites and operates properly. Refer to the installation instructions provided with the unit for the normal operating sequence.
7. After ignition, visually inspect the burner assembly to ensure that the flame is drawn directly into the center of the heat exchanger tube. In a properly adjusted burner assembly, the flame color should be blue with some light yellow streaks near the outer portions of the flame.

NOTE: The igniter may not ignite the gas until all air is bled from the gas line. If the ignition control locks out, turn the thermostat to its lowest setting and wait one minute then turn the thermostat to a point above room temperature and the igniter will try again to ignite the main burners. This process may have to be repeated several times before the burners will ignite. After the burners are lit, check all gas connections for leaks again with the soap and water solution.

Measuring the Manifold Pressure

The manifold pressure must be measured by installing a pressure gauge (Manometer, Magnehelic Meter, etc.) to the outlet end of the gas valve as follows:

1. Turn off all electrical power to the appliance.
2. Shut OFF the gas supply at the manual shutoff valve located outside of the appliance.
3. Using a 3/16" Allen wrench, remove the manifold pressure tap plug located on the outlet side of the gas valve. See [Figure 19 \(page 20\)](#).
4. Install an 1/8" NPT pipe thread fitting, that is compatible with a Manometer or similar pressure gauge.
5. Connect the Manometer or pressure gauge to the manifold pressure tap.
6. Set the room thermostat above room temperature to start the furnace.
7. Allow the furnace to operate for 3 minutes and then check the manifold pressure. Compare the measured value with the value listed in [Table 10 \(Propane\)](#) or [Table 12](#) or [Table 13, \(page 36\)](#) (Natural Gas).

Removing the Manometer/Pressure Gauge

After the manifold pressure is verified, the Manometer or pressure gauge must be removed from the gas valve.

1. Turn the thermostat to its lowest setting.
2. Turn OFF the main gas supply to the unit at the manual shut-off valve, which is located outside of the unit.
3. Turn OFF all of the electrical power supplies to the unit.
4. Remove the pressure gauge adapter from the gas valve and replace it with the 1/8" NPT manifold pressure plug that had been removed earlier. **NOTE:** Make sure the plug is tight and not cross-threaded.
5. Turn ON the electrical power to the unit.
6. Turn ON the main gas supply to the unit at the manual shut-off valve.

Completing the Conversion

WARNING:

Do not alter or remove the original rating plate from the furnace.

1. Affix the LP label from the orifice package to the rating plate.
2. Reinstall the appliance door.
3. Run the appliance through 3 complete cycles to assure proper operation.

ELECTRICAL WIRING

WARNING:

ELECTRICAL SHOCK, FIRE OR EXPLOSION HAZARD

Failure to follow safety warnings exactly could result in serious injury or property damage.

Improper servicing could result in dangerous operation, serious injury, death or property damage.

- Before servicing, disconnect all electrical power to furnace.
- When servicing controls, label all wires prior to disconnecting. Reconnect wires correctly.
- Verify proper operation after servicing.”

AVERTISSEMENT:

RISQUE DE CHOC ÉLECTRIQUE, D'INCENDIE OU D'EXPLOSION

Le non-respect des avertissements de sécurité pourrait entraîner un fonctionnement dangereux de l'appareil, des blessures graves, la mort ou des dommages matériels.

Un entreteïn incorrect pourrait entraîner un fonctionnement dangereux de l'appareil, des blessures graves, la mort ou des dommages matériels

- Couper toute alimentation électrique au générateur d'air chaud avant de prodéder aux travaux d'entreteïn.
- Au moment de l'entreteïn des commandes, étiquetez tous les fils avant de les débrancher. S'assurez de les raccorder correctement.
- S'assurez que l'appareil fonctionne adéquatement après l'entreteïn.

Line Voltage Wiring

- Electrical connections must be in compliance with all applicable local codes with the current revision of the National Electric Code (NFPA 70).
- For Canadian installations the electrical connections and grounding shall comply with the current Canadian Electrical Code (CSA C22.1 and/or local codes).
- It is recommended that the line voltage (115 VAC) to the furnace be supplied from a dedicated branch circuit containing the correct fuse or circuit breaker for the furnace as listed in [Table 5, \(page 24\)](#).

IMPORTANT NOTES:

If replacing any of the original wires supplied with the furnace, the replacement wire must be copper wiring and have a temperature rating of at least 105°F (40°C). For electrical specifications, refer to the furnace nameplate or [Table 5](#).

An electrical disconnect must be installed readily accessible from and located within sight of the furnace. See [Figure 21 \(page 24\)](#) or the wiring diagram label inside of the control door. Any other wiring methods must be acceptable to authority having jurisdiction.

Proper line voltage polarity must be maintained in order for the control system to operate correctly. Verify the incoming neutral line is connected to the white wire and the incoming HOT line is connected to the black wire. The furnace will not operate unless the polarity and ground are properly connected as shown in [Figure 21](#).

Thermostat / Low Voltage Connections

- The furnace is designed to be controlled by a 24 VAC thermostat. The thermostat's wiring must comply with the current provisions of the NEC (NFPA 70) and with applicable local codes having jurisdiction.
- The thermostat must be installed according to the instructions supplied by the thermostat manufacturer. Low voltage connections (24 VAC) from the thermostat are wired to the terminal strip on the integrated control in the furnace. [Figure 22 \(page 24\)](#) contains the proper connections for heating only (two-wire) and heating/cooling (four-wire) applications. Recommended minimum wire gauge for thermostat wiring is shown in [Table 5, \(page 24\)](#).
- The thermostat should be mounted about 5 feet above the floor on an inside wall. DO NOT install the thermostat on an outside wall or any other location where its operation may be adversely affected by radiant heat from fireplaces, sunlight, or lighting fixtures, and convective heat from warm air registers or electrical appliances. Refer to the thermostat manufacturer's instruction sheet for detailed mounting information.

FURNACE MODEL NUMBER M7RL-	FURNACE INPUT (BTUH)	CABINET WIDTH (IN.)	NOMINAL ELECTRICAL SUPPLY	MAXIMUM OPERATING VOLTAGE	MINIMUM OPERATING VOLTAGE	MAXIMUM FURNACE AMPERES	MINIMUM WIRE GAUGE	MAXIMUM FUSE OR CIRCUIT BREAKER AMPS*	MINIMUM CIRCUIT AMPACITY ¹	MAXIMUM OVERCURRENT PROTECTION ²
045A	45,000	19 7/8	115-60-1	127	103	11.0	14	20	13.1	21.7
060A	60,000	19 7/8	115-60-1	127	103	11.0	14	20	13.1	21.7
072A	72,000	19 7/8	115-60-1	127	103	10.4	14	20	12.4	20.4

NOTE: Minimum wire gauge and maximum fuse/circuit breaker amperage are based on MCA¹ and MOP² calculations. This furnace is approved for installation with a 15 or 20 amp fuse/circuit breaker however wiring sizing must adhere to current version of the NEC and/or applicable local codes depending upon the overcurrent protection.

THERMOSTAT WIRE GAUGE	RECOMMENDED THERMOSTAT WIRE LENGTH	
	2 - WIRE - HEATING	4 OR 5 WIRE - COOLING
24	55 ft.	25 ft.
22	90 ft.	45 ft.
20	140 ft.	70 ft.
18	225 ft.	110 ft.

* Time-delay fuses or circuit breakers are required.

Table 5. Wire Length & Voltage Specifications

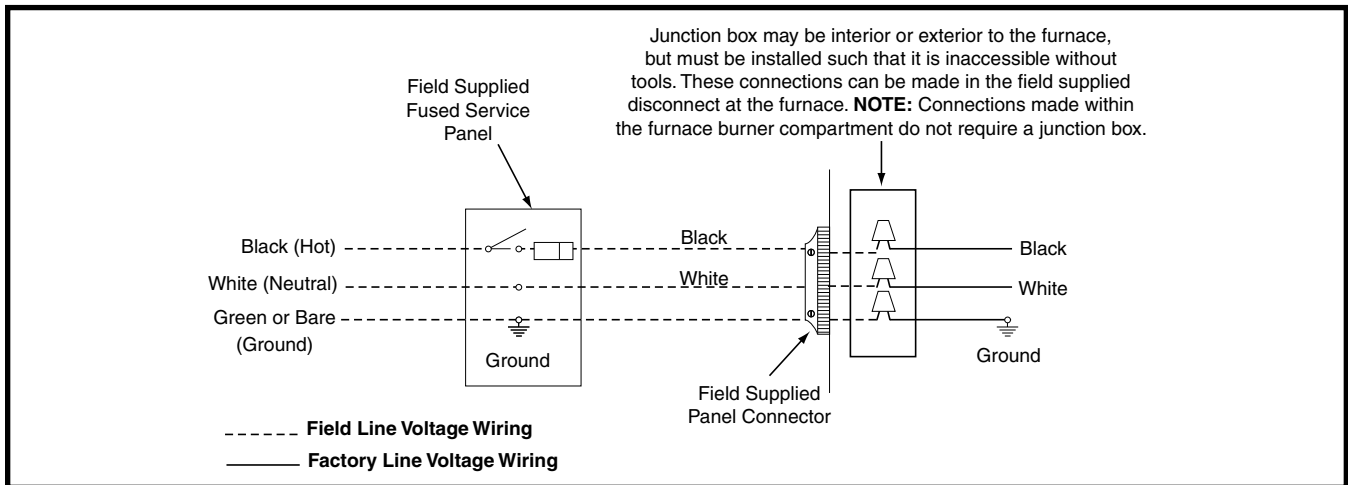

Figure 21. Line Voltage Field Wiring

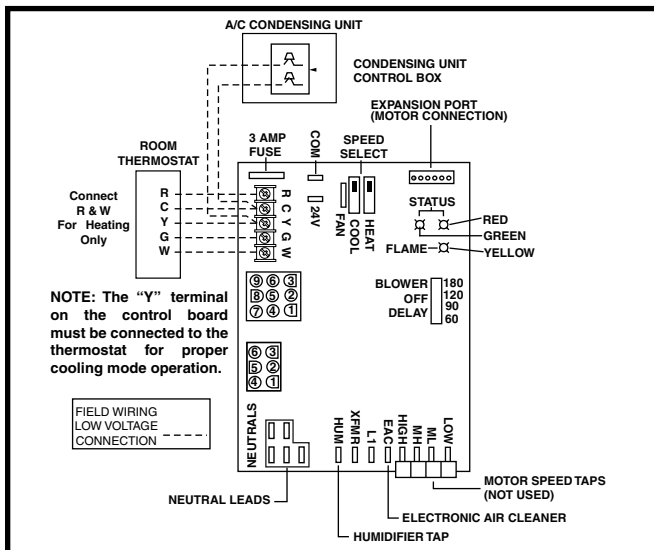

Figure 22. Low Voltage Field, Four-wire Heating/Cooling Applications

Heat Anticipator

Set the heat anticipator according to the instructions supplied by the thermostat manufacturer. To determine the heat anticipator setting:

1. Add the current draw of the system components; or
2. Measure the current flow on the thermostat R-W circuit after the circulating blower motor has started.

Grounding

WARNING:

To minimize personal injury, the furnace cabinet must have an uninterrupted or unbroken electrical ground. The controls used in this furnace require an earth ground to operate properly. Acceptable methods include electrical wire or conduit approved for ground service. Do not use gas piping as an electrical ground!

START-UP & ADJUSTMENTS

Pre-Start Check List

- √ Verify the polarity of the connections are correct, the line voltage power leads are securely connected and the furnace is properly grounded.
- √ Verify the thermostat wires (**R**, **W**, **Y**, & **G**) are securely connected to the correct leads on the terminal strip of the circuit board.
- √ Verify the gas line service pressure does not exceed 10.0 inches of W.C., and is not less than 4.5 inches W.C. for natural gas. For LP gas the line service pressure must not exceed 14 in. W.C., and must not be less than 11.0 in. W.C.
- √ Verify the roll-out and vent switches are closed. If necessary, press the red button to reset a switch. **DO NOT install a jumper wire across a switch to defeat its function. If a switch reopens on startup, DO NOT reset the switch without identifying and correcting the fault condition.**
- √ Verify the blower door is in place, closing the door switch in the line voltage circuit.
- √ Verify the gas line has been purged and all connections are leak free.

Start-up Procedures

Do not perform these steps until all of the checks in the previous steps have been completed:

1. Set the thermostat to the lowest setting.
2. Turn off all electrical power to the furnace.
3. Follow the Operating Instructions on the label attached to the furnace.
4. Set the thermostat above room temperature and verify the Operating Sequence (page 27).
5. After 5 minutes of operation, set the thermostat below room temperature and verify steps 9 - 10 of the Operating Sequence.

Verifying Input Rate

The input rate must be verified for each installation to prevent over-firing of the furnace. **NOTE:** The input rate must not exceed the rate shown on the furnace rating plate. At altitudes above 2,000 feet, it must not exceed that on the rating plate less 4% for each 1,000 feet. To determine the exact input rate, perform the following procedures:

1. Shut off all other gas fired appliances.
2. Start the furnace and run it for at least 3 minutes.
3. Measure the time (in seconds) required for the gas meter to complete one revolution.
4. Convert the time per revolution to cubic feet of gas per hour using Table 8, (page 35).
5. Multiply the gas flow rate in cubic ft per hr by the heating value of the gas in Btu per cubic ft to obtain the input rate in Btuh. See example above.

Example:

- Time for 1 revolution of a gas meter with a 1 cubic ft dial = 40 seconds.
- From Table 8 read 90 cubic ft gas per hr.
- Local heating value of the gas (obtained from gas supplier) = 1,040 Btu per cubic ft.
- Input rate = 1,040 x 90 = 93,600 Btuh.

Verifying & Adjusting Temperature Rise

After installation of the furnace, confirm the temperature rise of the furnace is within the limits specified on the rating plate. Any temperature rise outside the specified limits could result in premature failure of the heat exchanger.

For typical duct systems, the temperature rise will fall within the limits specified on the rating plate with the blower speed at the factory recommended setting. If the measured temperature rise is outside the specified limits, it may be necessary to change the speed of the blower.

NOTE: Lowering the blower speed will increase the temperature rise and a higher blower speed will decrease the temperature rise.

The furnace is equipped with a multi-speed motor. Heating and cooling speed selection is made by moving the switch on the integrated control located in the furnace.

1. Place thermometers in the return and supply air stream as close to the furnace as possible. **IMPORTANT: The thermometer on the supply air side must be shielded from direct radiation from the heat exchanger to avoid false readings.**
2. Consult Table 6, (page 26) and the rating plate for the proper circulating air flow and temperature rise.

NOTE: This furnace is designed to operate with a maximum external pressure rise of 0.3 inches of water column. It is important that the duct system be designed to provide the correct flow rates and external pressure rise. An improperly designed duct system can result in nuisance shutdowns, and comfort or noise issues.

3. Adjust all registers and duct dampers to the desired position and run the furnace for 10 to 15 minutes before taking any temperature readings. The temperature rise is the difference between the supply and return air temperatures.

Verifying Burner Operation

CAUTION:

The door over the burners may only be open for inspection purposes only. The door must be installed during unattended operation.

1. Set the thermostat above room temperature and observe the ignition sequence. **NOTE:** The burner flame should carry over immediately between all burners without lifting off, curling, or floating. The flames should be blue, without yellow tips.
2. After validating the flame, change thermostat setting to below room temperature.
3. Verify the burner flame is completely extinguished.
4. Replace the burner compartment door.

Verifying Operation of the Supply Air Limit Switch

NOTE: A properly functioning limit switch should turn off the gas valve when the return is blocked (time depends on how well the return air is blocked). The circulating air and combustion blowers should continue to run when the limit switch opens.

1. Verify the blower door is securely mounted in place and that there is power to the furnace.
2. Block the return airflow to the furnace by installing a close-off plate in place of or upstream of the filter(s).
3. Set the thermostat above room temperature and observe the Operating Sequence.
4. Remove the close-off immediately after the limit switch opens. If the furnace continues to operate with no return air, set the thermostat below room temperature, shut off power to the furnace, and replace the limit switch.

MODEL NUMBER & HEATING INPUT (BTUH)	MOTOR SPEED	EXTERNAL STATIC PRESSURE (INCHES WATER COLUMN)										RECOMMENDED A/C TON
		0.1		0.2		0.3		0.4		0.5		
		CFM	RISE	CFM	RISE	CFM	RISE	CFM	RISE	CFM	RISE	
M7RL 045 45,000	HIGH*	1580	25	1530	26	1485	27	1435	28	1380	29	4
	MED HIGH	1355	29	1330	30	1300	30	1265	31	1220	32	3
	MED LOW	1185	33	1165	34	1140	35	1100	36	1065	37	2 1/2
	LOW**	910	44	890	45	865	46	835	47	810	49	2
M7RL 060 60,000	HIGH*	1580	33	1530	35	1485	36	1435	37	1380	38	4
	MED HIGH**	1355	39	1330	40	1300	41	1265	42	1220	43	3
	MED LOW	1185	45	1165	45	1140	46	1100	48	1065	50	2 1/2
	LOW	910	58	890	59	865	61	835	63	810	65	2
M7RL 072 72,000	HIGH*	1555	41	1505	42	1460	43	1405	45	1350	47	4
	MED HIGH**	1490	43	1450	44	1405	45	1355	47	1310	48	3
	MED LOW	1005	63	975	65	950	67	925	69	875	72	2 1/2
	LOW	900	70	875	72	845	75	810	78	775	82	2

NOTES:

* Factory Set Cooling Speed

** Factory Set Heating Speed

1. Temperature rises (°F) in the table are approximate. Actual temperature rises may vary.
2. Temperature rises shaded in gray are for reference only. These conditions are not recommended.
3. Airflow performance is with a filter.

Table 6. Maximum Airflow & Temperature Rises (° F)

OPERATING SEQUENCE

The operating sequences for the heating, cooling, and fan modes are described below. Refer to the field and furnace wiring diagrams: [Figure 22 \(page 24\)](#) and [\(Figure 28 \(page 34\)\)](#).

Heating Cycle

1. The thermostat calls for heat by energizing the **W** terminal with 24VAC.
2. The control verifies the pressure switch is open.
3. If the pressure switch is open, the control energizes the inducer and waits for the pressure switch to close. The pressure switch must close within 10 seconds.
4. The control runs the inducer for a 30 second pre-purge.
5. The control energizes the Hot Surface Igniter (HSI) output for the appropriate warm-up time limit.
6. The control energizes the main gas valve for 3 seconds.
7. If the flame proved and ignites the gas, the control de-energizes the HSI. The gas valve and inducer remains energized. The control goes to blower on delay.
8. If flame is present, the control energizes the blower on the selected HEAT speed 30 seconds after the gas valve opened. The gas valve and inducer remain energized.
9. When the thermostat demand for heat is satisfied, the control de-energizes the gas valve. The Inducer output remains on for a 30 second post-purge period.
10. Blower off timing begins when the thermostat is satisfied. The control will operate at the selected HEAT speed of 60, 90, 120, or 180 seconds. If the blower off delay jumper is not present, the fan should still operate for 120 seconds at the selected HEAT speed. The Indoor blower motor is de-energized after a blower off delay as selected by the movable jumper.

Cooling Cycle

1. The thermostat calls for cooling by energizing the **Y** terminal with 24VAC.
2. The control energizes the blower in cooling speed and sends 24VAC to the contactor in the condensing unit
3. When the thermostat removes the call for cooling, the contactor in the outdoor condensing unit is de-energized and the control continues to run the fan for a period of 60 seconds.

Fan Mode

- When the thermostat energizes the **G** terminal for continuous fan (without calling for heat or cooling), the indoor fan is energized on the selected FAN speed.
- If a call for cooling occurs during continuous fan, the blower will switch over to the selected COOL speed.
- If the **W** terminal receives a call for heat during continuous fan, the blower will de energize.
- A call for fan is ignored while in lockout.

MAINTENANCE

Proper maintenance is most important to achieve the best performance from a furnace. Follow these instructions for years of safe, trouble free operation.

WARNING:

ELECTRICAL SHOCK, FIRE OR EXPLOSION HAZARD

Failure to follow safety warnings exactly could result in serious injury or property damage.

Improper servicing could result in dangerous operation, serious injury, death or property damage.

- **Before servicing, disconnect all electrical power to furnace.**
- **When servicing controls, label all wires prior to disconnecting. Reconnect wires correctly.**
- **Verify proper operation after servicing.”**

AVERTISSEMENT:

RISQUE DE CHOC ÉLECTRIQUE, D'INCENDIE OU D'EXPLOSION

Le non-respect des avertissements de sécurité pourrait entraîner un fonctionnement dangereux de l'appareil, des blessures graves, la mort ou des dommages matériels.

Un entreteïn incorrect pourrait entraîner un fonctionnement dangereux de l'appareil, des blessures graves, la mort ou des dommages matériels

- **Couper toute alimentation électrique au générateur d'air chaud avant de prodéder aux travaux d'entreteïn.**
- **Au moment de l'entreteïn des commandes, étiquetez tous les fils avant de les débrancher. S'assurer de les raccorder correctement.**
- **S'assurer que l'appareil fonctionne adéquatement après l'entreteïn.**

- These maintenance instructions are primarily intended to assist qualified technicians experienced in the proper maintenance and operation of this appliance.
- Always close the door on the furnace after servicing or cleaning/changing the filters. **Do not operate the furnace without the door closed.**
- Verify the thermostat is properly installed and will not be affected by drafts or heat from lamps or other appliances.
- To achieve the best performance and minimize equipment failure it is recommended that a yearly maintenance checkup be performed. At a minimum, this check should include the following items:

Air Filter(s)

WARNING:

Never operate the furnace without a filter in place. Dust and lint can build up on internal components, resulting in loss of efficiency, equipment damage, and possible fire.

An air filter is supplied with the furnace as shipped from the factory. Filters should be changed or cleaned monthly during the heating season. Newly built or renovated homes may require more frequent changing until the construction dust has minimized.

Filters designed to remove smaller particles such as pollen, may require additional maintenance.

Blower Compartment

Dirt and lint can create excessive loads on the motor resulting in higher than normal operating temperatures and shortened service life. It is recommended that the blower compartment be cleaned of dirt or lint that may have accumulated in the compartment or on the blower and motor as part of the annual inspection.

Cleaning of Burners

If the burners must be cleaned, follow steps 1-12. See [Figure 23 \(page 29\)](#) for component location.

1. Shut off gas supply to the furnace at the meter or at a manual valve in the supply piping.
2. Turn off all power to the furnace and set the thermostat to it's lowest setting.
3. Turn the gas control knob to the OFF position. See [Figure 19 \(page 20\)](#).
4. Disconnect the wires from the gas valve, igniter, flame sensor, and flame rollout switch.

CAUTION:

To prevent damage to the unit or internal components, it is recommended that two wrenches be used when loosening or tightening nuts. Do not over tighten!

5. Using two wrenches, separate the ground-joint union in the gas supply piping at the furnace.
6. Remove the piping between the gas valve and the ground-joint union. (If applicable).
7. Remove 6 screws securing the burner box door. See [Figure 20 \(page 21\)](#).
8. Remove 4 screws securing the manifold assembly to the burner box.

9. Remove 4 screws from the corners of the box and carefully remove the burner assembly from the furnace.

IMPORTANT NOTE:

DO NOT damage the igniter while removing the burner assembly.

10. Inspect the burners for accumulated dust or debris. If necessary carefully clean them with a soft wire brush and a vacuum cleaner.

IMPORTANT NOTE:

DO NOT damage the igniter while cleaning the burner assembly.

11. Replace all the parts in reverse order that they were removed.
12. Follow the lighting instructions found on the furnace door to return the furnace to operation. Verify proper operation after servicing.

Vent System

WARNING:

Holes in the vent pipe or heat exchanger can cause combustion products to enter the home. Replace the vent pipe or heat exchanger if leaks are found. Failure to prevent the circulation of combustion products into the living space can create potentially hazardous conditions including carbon monoxide poisoning that could result in personal injury or death.

Check the inlet pipe (if applicable) and outlet pipe to ensure they are not blocked by debris. Any damaged section of vent pipe must be replaced, and any obstruction or blockage must be removed prior to operating the furnace.

Heat Exchanger & Burner Maintenance

The furnace should operate for many years without soot buildup in the flue passageways, however, the flue, vent system, and burners should be inspected and cleaned (if required) by a qualified service technician annually to ensure continued safe operation. Pay attention to any deterioration from corrosion or other sources.

Lubrication

The bearings in the blower motor and inducer blower used in these furnaces are pre-lubricated and sealed by the manufacturer. No further oiling of the bearings is required for the life of the motor.

TROUBLESHOOTING

If the furnace fails to operate check the following:

- Is the thermostat operating properly?
- Are the blower compartment door(s) in place?
- Is the furnace disconnect closed?
- Has the circuit breaker tripped or the control board fuse burned open?
- Is the gas turned on?
- Are any manual reset switches open?
- Is the filter dirty or plugged?
- Is the flame sensor coated? (Remove and clean with steel wool. **(Do not use emery cloth or sandpaper!)**)
- Is there blockage in the condensate drain switch? Also verify that there is no double trapping of condensate.
- Is the secondary heat exchanger free of debris and clogs?
- Is evaporator coil clean and free of debris (If applicable).
- Are all the LED's on the furnace control board constantly ON? If not, refer to [Table 7](#) or the wiring diagram ([Figure 28](#) (page 34)) to determine fault condition.

IMPORTANT NOTE:

The furnace will lock out after 5 failed attempts for ignition and will try again every hour if the call for heat remains.

- If the inducer blower is operating, and items above have been verified, check the blower limit switch and reset if necessary. See [Figure 23](#) for component location.
- If the furnace operates when the Blower Limit Switch is reset, contact a qualified service technician to identify and repair the problem.
- If the furnace still doesn't operate, check the flame roll-out switch and reset if necessary.
- If the furnace operates when the flame rollout switch is reset, contact a qualified service technician to identify and repair the problem.

DIAGNOSTIC DESCRIPTION	GREEN LED	RED LED
Control Fault (No Power)	Off	Off
L1/Neutral Polarity Fault	Flash	Flash
1 Hour Lockout	Alternating Flash	
Normal Operation	On	On
Pressure Switch Closed Fault	On	Flash
Pressure Switch Open Fault	Flash	On
Open Limit Switch Fault	Flash	Off
DIAGNOSTIC DESCRIPTION	YELLOW LED	
Low Flame Sensor Signal	Continuous Flash	
Flame Present	On	

Table 7. Control Board Fault Conditions

DESCRIPTION OF COMPONENTS

The descriptions below are various functional components that affect the operation and shutting down of this furnace. Some of these components and their locations are shown in [Figure 23](#). If any component of the furnace must be replaced, use only factory authorized replacement parts specified in the Replacement Parts List provided online.

Blower Limit Switch: Prevents operation when blower is not operational.

Flame Sensor: Verifies when a flame has carried over from the igniter to the opposite end burner. If no flame is detected, the furnace will shut down within 4 seconds.

Flame Roll-Out Switch: Verifies that the burner flames are drawn into the heat exchanger tubes. If the burner flames are not properly drawn into the heat exchanger, the flame roll-out switch will close the gas valve and initiate the shutdown cycle.

Gas Valve: Controls the flow of gas to the burners. When the gas valve is energized it automatically opens and regulates the gas pressure in the manifold.

Inducer Assembly: Vents products of combustion to the outside.

Pressure Switch: Verifies that the inducer is drawing the combustion gases through the heat exchanger. The pressure switch prevents furnace operation with excessive flue/condensate blockage or improper inducer operation.

Main Air Limit Switch: Prevents the air temperature leaving the furnace from exceeding the maximum allowable outlet air temperature.

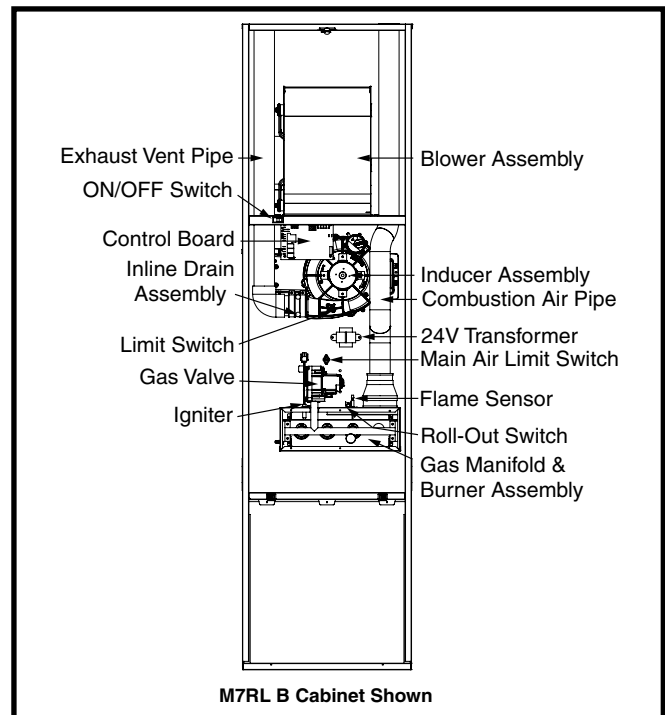

Figure 23. Furnace Components

FIGURES & TABLES

Cabinet Dimensions

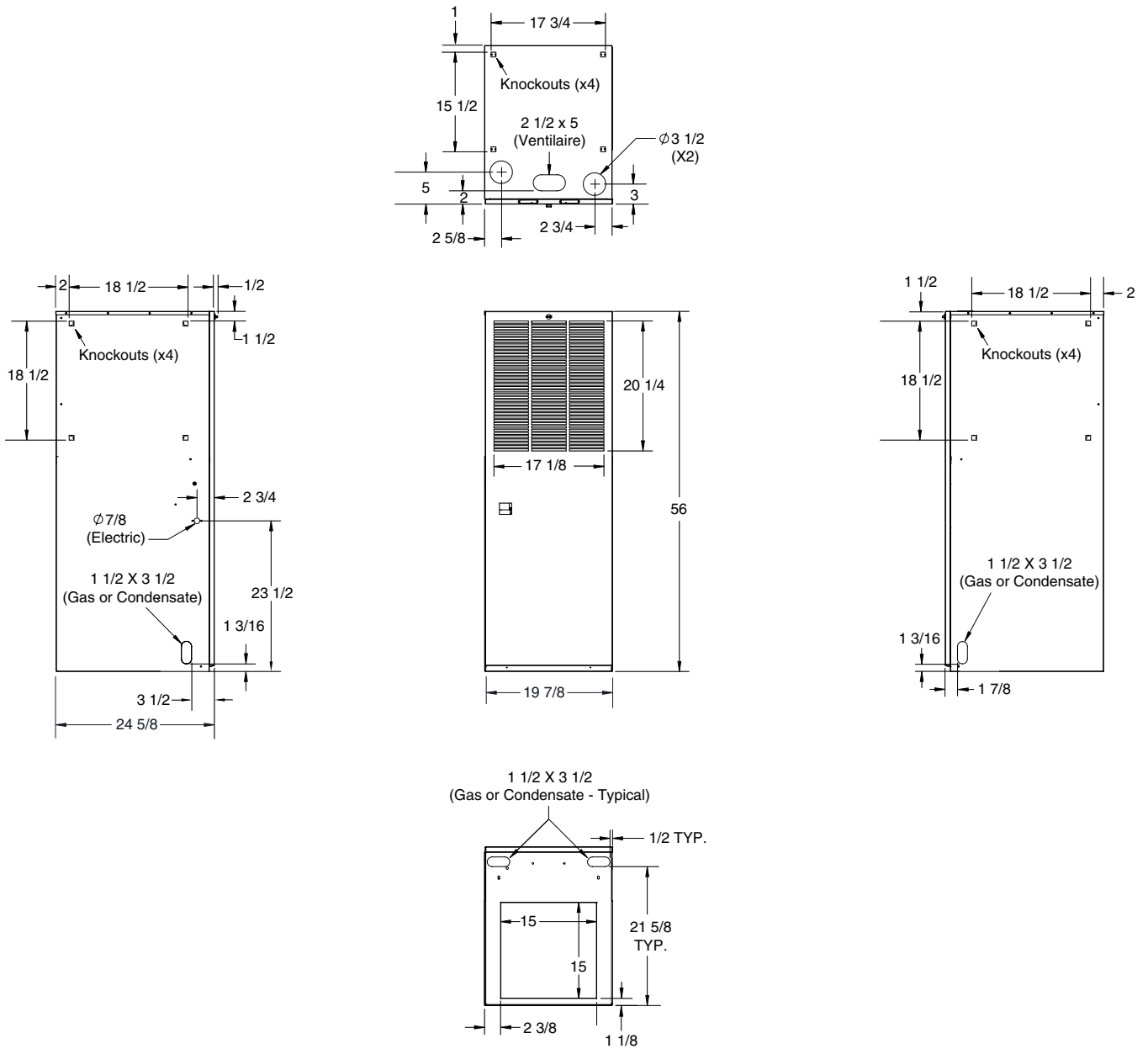

Figure 24. A-Series Cabinets (Front Return)

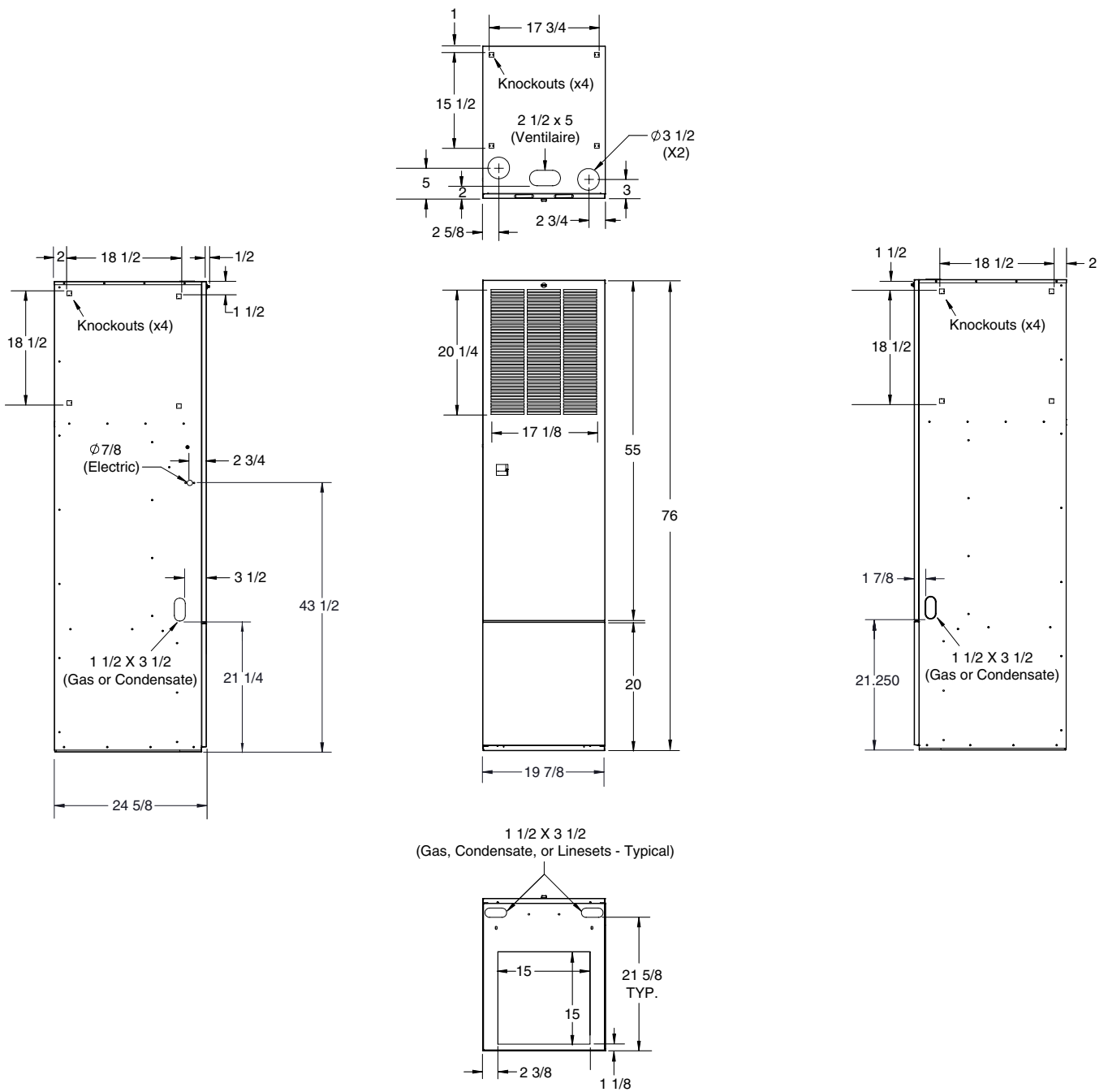

Figure 25. B-Series Cabinets (Front Return)

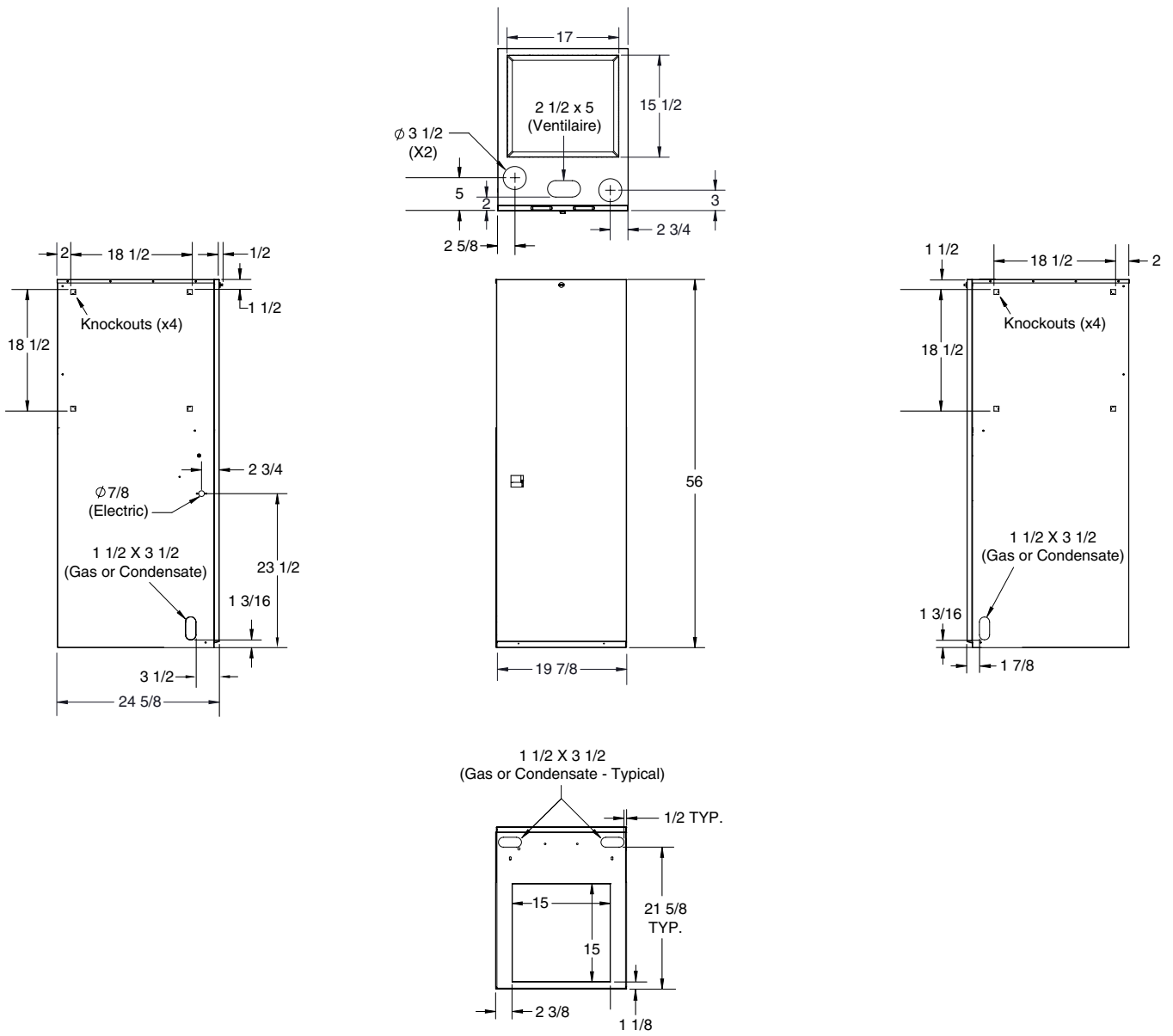

Figure 26. A-Series Cabinets (Top Return Air)

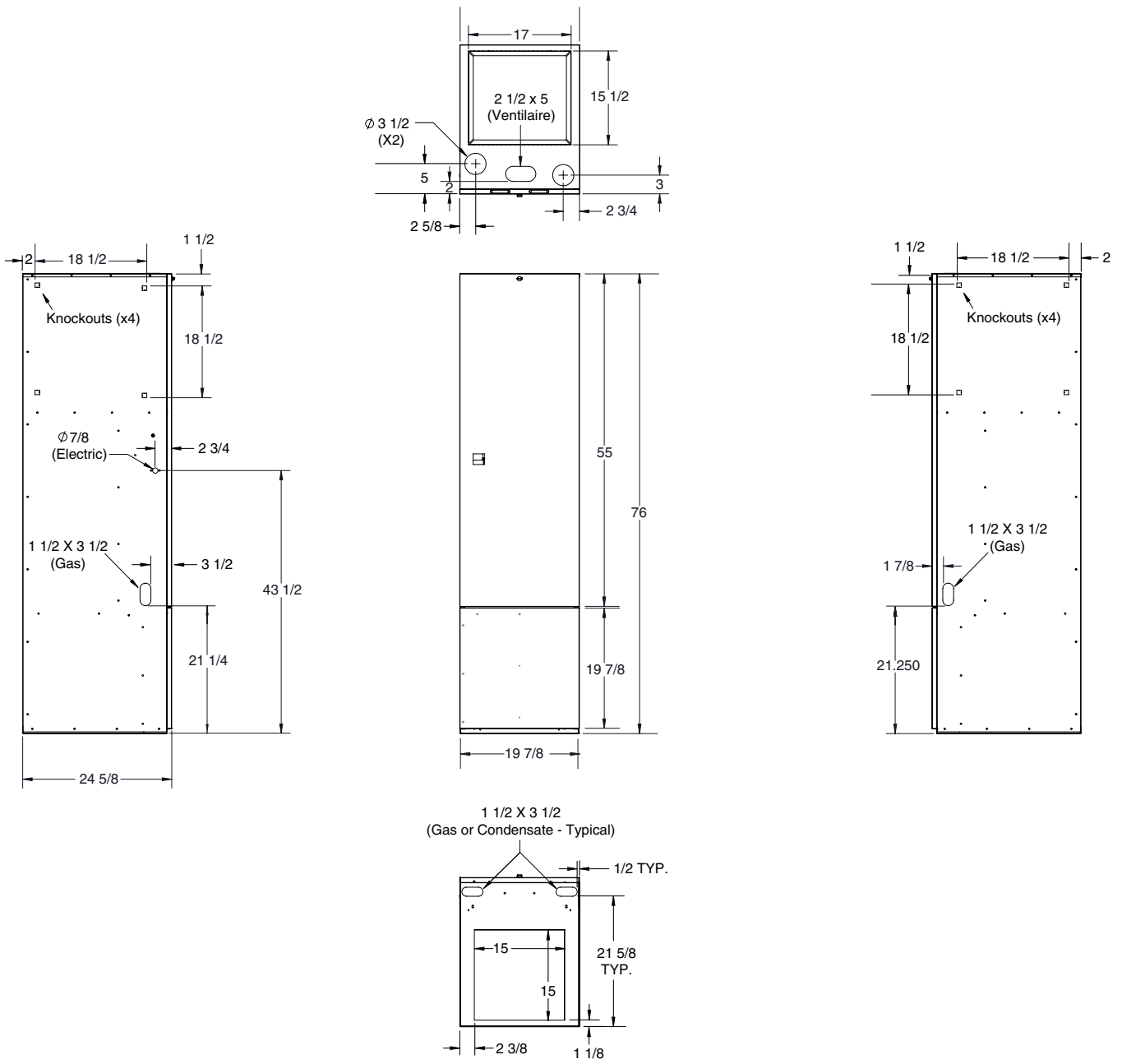

Figure 27. B-Series Cabinets (Top Return Air)

Electrical Information

WIRING DIAGRAM

For 90+ Single Stage Furnaces

Refer to the Installation Instructions provided with the furnace for the proper heating and cooling speeds for your application.

FAULT CONDITIONS		
Diagnostic Description	Green LED	Red LED
Control Fault (No Power)	Off	Off
L1 / Neutral Polarity Fault	Flash	Flash
1 Hour Lockout	Alternating Flash	Flash
Normal Operation	On	On
Pressure Switch Closed Fault	On	Flash
Pressure Switch Open Fault	Flash	On
Open Limit Switch Fault	Flash	Off
Diagnostic Description		
Low Flame Sensor Signal	Continuous Flash	On
Flame Present	On	On

If any of the original wire as supplied with the furnace must be replaced, it must be replaced with wiring material having a temperature of at least 105° C.

Use copper conductors only.

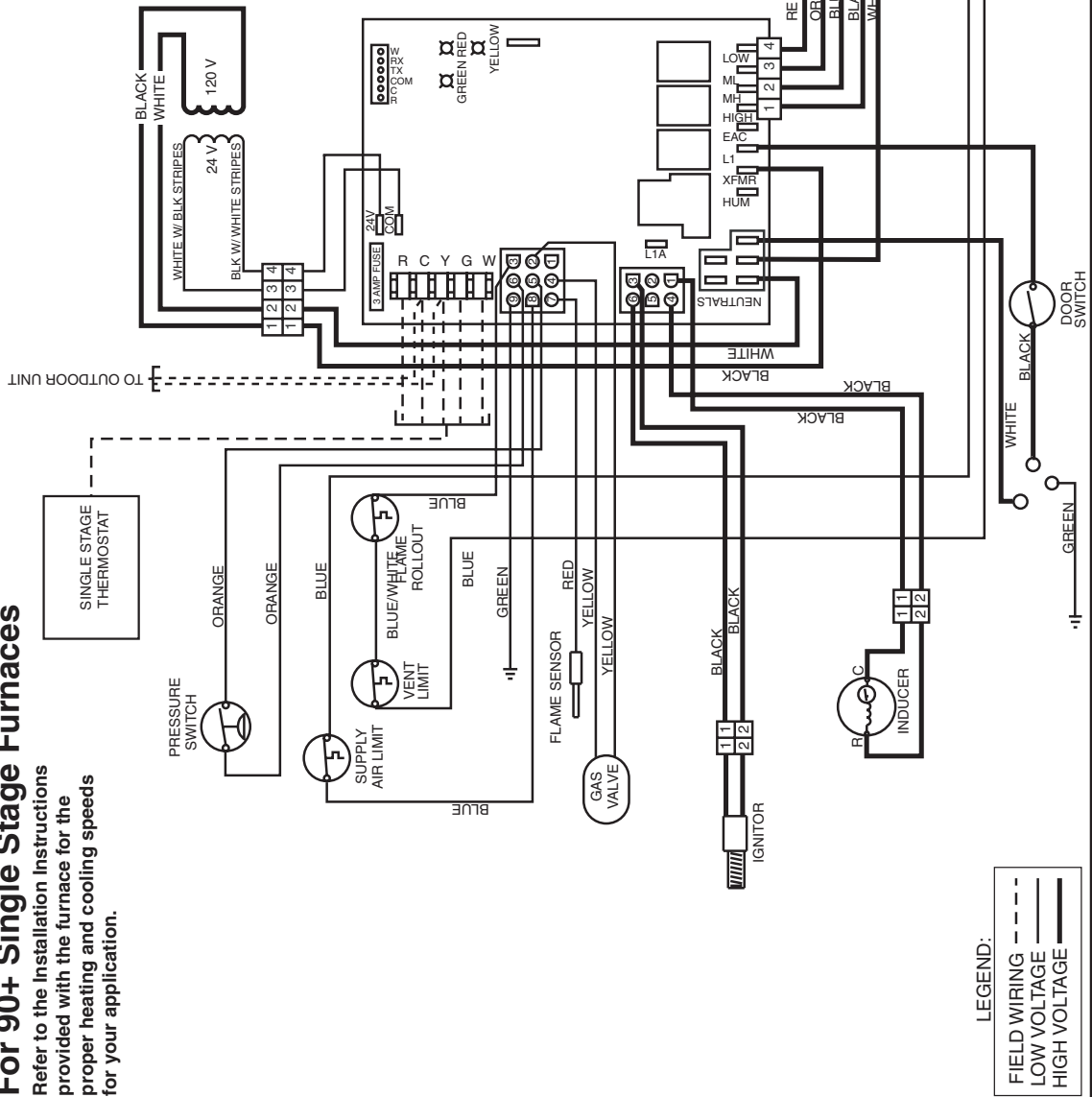

711216C
(Replaces 711216B)
07/14



Figure 28. M7RL Wiring Diagram

Gas Information

GAS FLOW RATES (CUBIC FEET PER HOUR)			
TIME FOR ONE REVOLUTION (SECONDS)	CUBIC FEET PER REVOLUTION OF GAS METER		
	1	5	10
10	360	1,800	3,600
12	300	1,500	3,000
14	257	1,286	2,571
16	225	1,125	2,250
18	200	1,000	2,000
20	180	900	1,800
22	164	818	1,636
24	150	750	1,500
26	138	692	1,385
28	129	643	1,286
30	120	600	1,200
32	113	563	1,125
34	106	529	1,059
36	100	500	1,000
38	95	474	947
40	90	450	900
42	86	429	857
44	82	409	818
46	78	391	783
48	75	375	750
50	72	360	720
52	69	346	692
54	67	333	667
56	64	321	643
58	62	310	621
60	60	300	600
62	58	290	581
64	56	281	563

GAS FLOW RATES (CUBIC FEET PER HOUR)			
TIME FOR ONE REVOLUTION (SECONDS)	CUBIC FEET PER REVOLUTION OF GAS METER		
	1	5	10
66	55	273	545
68	53	265	529
70	51	257	514
72	50	250	500
74	49	243	486
76	47	237	474
78	46	231	462
80	45	225	450
82	44	220	439
84	43	214	429
86	42	209	419
88	41	205	409
90	40	200	400
92	39	196	391
94	38	191	383
96	38	188	375
98	37	184	367
100	36	180	360
102	35	176	353
104	35	173	346
106	34	170	340
108	33	167	333
110	33	164	327
112	32	161	321
114	32	158	316
116	31	155	310
118	31	153	305
120	30	150	300

Table 8. Gas Flow Rates

CAPACITY OF BLACK IRON GAS PIPE (CU. FT. PER HOUR) FOR NATURAL GAS (SPECIFIC GRAVITY - 0.60)								
NOMINAL PIPE DIAMETER (IN.)	LENGTH OF PIPE RUN (FEET)							
	10	20	30	40	50	60	70	80
1/2	130	90	75	65	55	50	45	40
3/4	280	190	150	130	115	105	95	90
1	520	350	285	245	215	195	180	170
1 1/4	1,050	730	590	500	440	400	370	350
1 1/2	1,600	1,100	890	760	670	610		

$$\text{Cubic Feet Per Hour Required} = \frac{\text{Input To Furnace (Btu/hr)}}{\text{Heating Value of Gas (Btu/Cu. Ft.)}}$$

NOTE: The cubic feet per hour listed above must be greater than the cubic feet per hour of gas flow required by the furnace. To determine the cubic feet per hour of gas flow required by the furnace, divide the input rate of the furnace by the heating value (from gas supplier) of the gas.

Table 9. Gas Pipe Capacities

ORIFICES FOR PROPANE GAS MANIFOLD PRESSURE = 10 IN. W.C.			
ALTITUDE ABOVE SEA LEVEL	INPUT (BTU)		
	45,000	60,000	72,000
0 to 1,999 FT	57	55	56
2,000 to 2,999 FT	57	55	56
3,000 to 3,999 FT	57	55	56
4,000 to 4,999 FT	57	56	56
5,000 to 5,999 FT	58	56	56
6,000 to 6,999 FT	59	56	57
7,000 to 7,999 FT	59	56	57
8,000 to 8,999 FT	60	56	57
9,000 to 9,999 FT	61	57	57

Table 10. Orifices for Propane Gas

LOCAL HEATING VALUES FOR NATURAL GAS									
ALTITUDE ABOVE SEA LEVEL	BTU PER CUBIC FOOT								
	650	700	750	800	850	900	950	1,000	1,050
2,000 FT	LOW	LOW	LOW	LOW	LOW	LOW	HIGH	HIGH	HIGH
3,000 FT	LOW	LOW	LOW	LOW	LOW	LOW	HIGH	HIGH	HIGH
4,000 FT	LOW	LOW	LOW	LOW	LOW	HIGH	HIGH	HIGH	HIGH
5,000 FT	LOW	LOW	LOW	LOW	LOW	HIGH	HIGH	HIGH	HIGH
6,000 FT	LOW	LOW	LOW	LOW	HIGH	HIGH	HIGH	HIGH	HIGH
7,000 FT	LOW	LOW	LOW	LOW	HIGH	HIGH	HIGH	HIGH	HIGH
8,000 FT	LOW	LOW	LOW	HIGH	HIGH	HIGH	HIGH	HIGH	HIGH
9,000 FT	LOW	LOW	LOW	HIGH	HIGH	HIGH	HIGH	HIGH	HIGH
10,000 FT	LOW	LOW	HIGH	HIGH	HIGH	HIGH	HIGH	HIGH	HIGH

Table 11. Natural Gas Heating Values

HIGH HEATING VALUE & MANIFOLD PRESSURE = 3.5 IN. W.C.			
ALTITUDE ABOVE SEA LEVEL	INPUT (BTU)		
	45,000	60,000	72,000
0 to 1,999 FT	49	45	47
2,000 to 2,999 FT	50	46	48
3,000 to 3,999 FT	50	46	48
4,000 to 4,999 FT	51	47	48
5,000 to 5,999 FT	51	47	49
6,000 to 6,999 FT	51	48	49
7,000 to 7,999 FT	52	48	50
8,000 to 8,999 FT	52	49	50
9,000 to 9,999 FT	52	49	50

**Table 12. Orifices for Natural Gas
High Heating Value**

LOW HEATING VALUE & MANIFOLD PRESSURE = 3.5 IN. W.C.			
ALTITUDE ABOVE SEA LEVEL	INPUT (BTU)		
	45,000	60,000	72,000
0 to 1,999 FT	49	45	47
2,000 to 2,999 FT	49	45	47
3,000 to 3,999 FT	49	45	47
4,000 to 4,999 FT	50	45	47
5,000 to 5,999 FT	50	45	47
6,000 to 6,999 FT	50	46	48
7,000 to 7,999 FT	51	47	48
8,000 to 8,999 FT	51	47	49
9,000 to 9,999 FT	51	48	49

**Table 13. Orifices for Natural Gas
Low Heating Value**

Venting Information

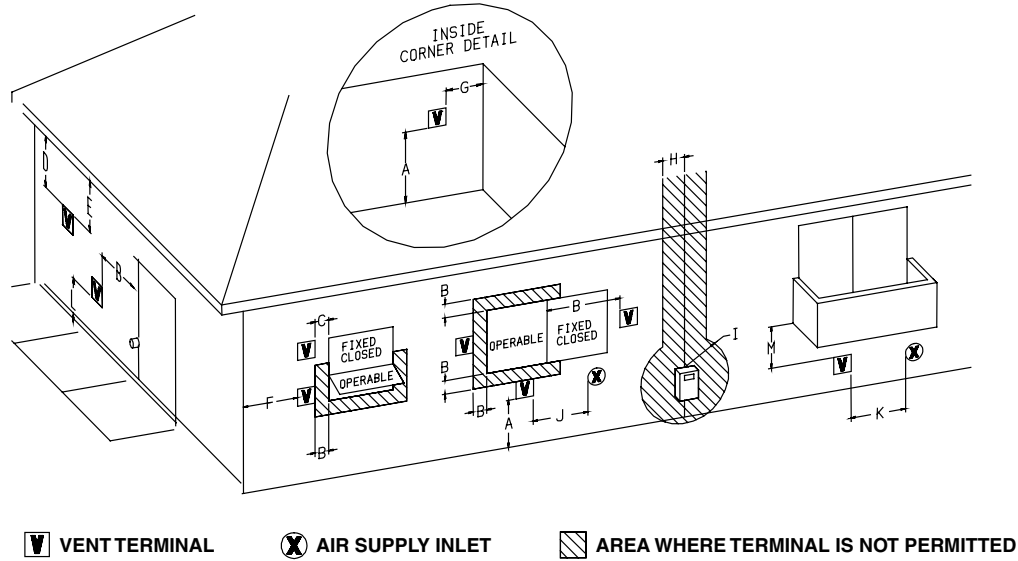

CLEARANCE LOCATION	CANADIAN INSTALLATIONS ^A	US INSTALLATIONS ^B		
	DIRECT VENT (2-PIPE) & CONVENTIONAL VENT (1-PIPE) FURNACES	DIRECT VENT (2-PIPE) FURNACES	CONVENTIONAL VENT (1-PIPE) FURNACES	
A	Clearance above grade, veranda, porch, deck, balcony, or maximum expected snow level.	12 inches (30cm)	12 inches (30cm)	12 inches (30cm)
B	Clearance to window or door that may be opened.	6 inches (15cm) for appliances < 10,000 Btuh (3kW)	6 inches (15cm) for appliances < 10,000 Btuh (3kW)	4 ft. (1.2m) below or to side of opening; 1 ft. (300mm) above opening
		12 inches (30cm) for appliances 10,000 Btuh - 100,000 Btuh (30kW)	9 inches (23cm) for appliances 10,000 Btuh - 50,000 Btuh (30kW)	
		36 inches (91cm) for appliances > 100,000 Btuh (30Kw)	12 inches (30cm) for appliances > 50,000 Btuh (30Kw)	
C	Clearance to permanently closed window	12 inches (30cm) suggested or as needed to avoid condensation on glass.	12 inches (30cm) suggested or as needed to avoid condensation on glass.	
D	Vertical clearance to ventilated soffit located above the terminal within a horizontal distance of 2 feet (61cm) from the center line of the terminal.	Clearance must be greater than the depth of the soffit unless it complies with Figure 28 (page 37)	Clearance must be greater than the depth of the soffit unless it complies with Figure 28 (page 37)	
E	Clearance to unventilated soffit.	Clearance must be greater than the depth of the soffit unless it complies with Figure 28 (page 37)	Clearance must be greater than the depth of the soffit unless it complies with Figure 28 (page 37)	
F	Clearance to outside corner.	All Clearances in this Figure apply on both walls	All Clearances in this Figure apply on both walls	
G	Clearance to inside corner.	All Clearances in this Figure apply on both walls	All Clearances in this Figure apply on both walls	
H	Clearance to each side of center line extended above meter/regulator assembly.	3 feet (91cm) within a height 15 feet above the meter/regulator assembly	3 feet (91cm) within a height of 15 feet	
I	Clearance to service regulator vent outlet.	3 feet (91cm)	3 feet (91cm) in any direction	
J	Clearance to non-mechanical air supply inlet to building or the combustion air inlet to any other appliance.	6 inches (15cm) for appliances < 10,000 Btuh (3kW)	6 inches (15cm) for appliances < 10,000 Btuh (3kW)	4 ft. (1.2m) below or to side of opening; 1 ft. (300mm) above opening
		12 inches (30cm) for appliances 10,000 Btuh - 100,000 Btuh (30kW)	9 inches (23cm) for appliances 10,000 Btuh - 50,000 Btuh (30kW)	
		36 inches (91cm) for appliances > 100,000 Btuh (30Kw)	12 inches (30cm) for appliances > 50,000 Btuh (30Kw)	
K	Clearance to mechanical air supply inlet.	6 feet (1.83m)	3 feet (91cm) above if within 10 feet (3m) horizontally	3 ft. (91cm) above if within 10 feet (3m) horizontally
L	Clearance above paved sidewalk or driveway located on public property.	7 feet (2.13m) ^c	7 feet (2.13m) ^c	7 ft. (2.13m)
M	Clearance under open veranda, porch, deck, or balcony.	12 inches (30cm) ^d	12 inches (30cm) ^d	12 inches (30cm) ^d

NOTES:

- a = In accordance with the current CSA B149.1 Natural Gas and Propane Installation Guide Code
- b = In accordance with the current ANSI Z223.1 / NFPA 54 Natural Fuel Gas Code
- c = A vent shall not terminate directly above a sidewalk or paved driveway that is located between two single family dwellings and serves both dwellings.
- d = Permitted only if veranda, porch, deck, or balcony is fully open on a minimum of two sides beneath the floor.

Table 14. Vent Termination Clearances

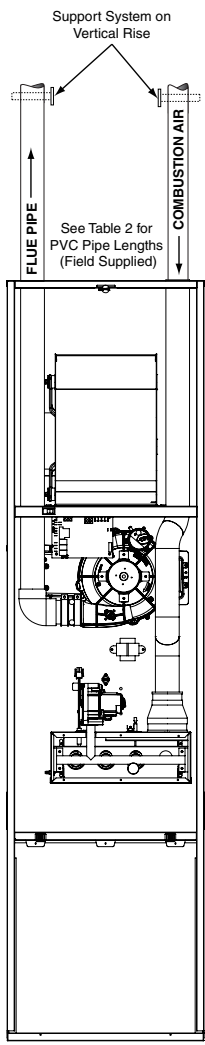

VERTICAL VENTING

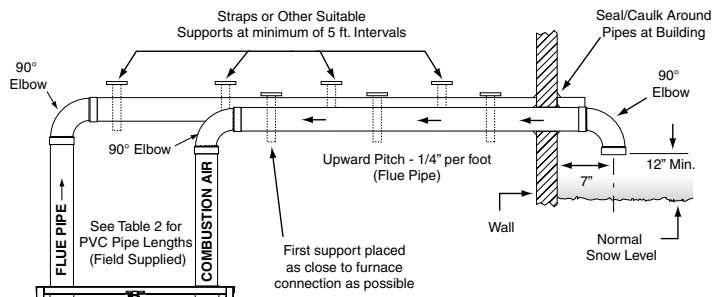

M7RL B Cabinet Shown

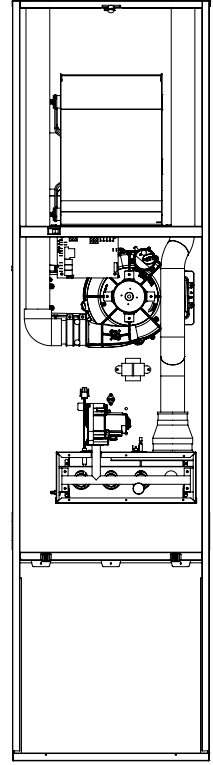

HORIZONTAL VENTING

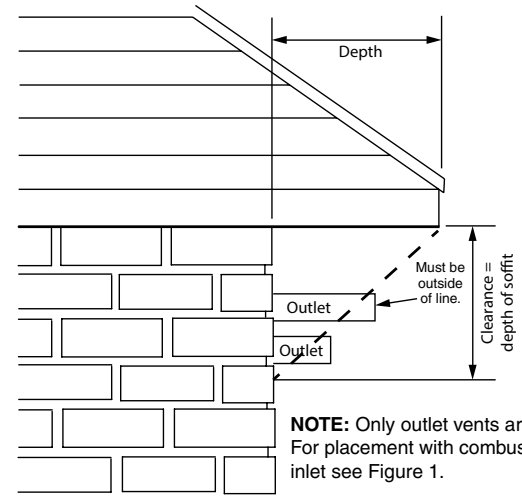

CLEARANCES FROM SOFFIT

NOTE: Only outlet vents are shown. For placement with combustion air inlet see Figure 1.

Figure 29. Horizontal / Vertical Venting & Clearances from Soffit

INSTALLATION CHECKLIST

ATTENTION INSTALLERS:

It is your responsibility to know this product better than your customer. This includes being able to install the product according to strict safety guidelines and instructing the customer on how to operate and maintain the equipment for the life of the product. Safety should always be the deciding factor when installing this product and using common sense plays an important role as well. Pay attention to all safety warnings and any other special notes highlighted in the manual. Improper installation of the furnace or failure to follow safety warnings could result in serious injury, death, or property damage.

These instructions are primarily intended to assist qualified individuals experienced in the proper installation of this appliance. Some local codes require licensed installation/service personnel for this type of equipment. Please read all instructions carefully before starting the installation. Return these instructions to the customer's package for future reference.

INSTALLER NAME:		
CITY:	STATE:	
INSTALLATION ADDRESS:		
CITY:	STATE:	
UNIT MODEL #		
UNIT SERIAL #		
Minimum clearances per Table 1, (page 5) ?	YES	NO
Has the owner's information been reviewed with the home-owner?	YES	NO
Has the literature package been left near the furnace?	YES	NO

PROPOSITION 65 WARNING:

WARNING: This product contains chemicals known to the state of California to cause cancer.

WARNING: This product contains chemicals known to the state of California to cause birth defects or other reproductive harm.

ELECTRICAL SYSTEM		
Electrical connections tight?	YES	NO
Line voltage polarity correct?	YES	NO
Supply Voltage: _____ VOLTS		
Has the thermostat been calibrated?	YES	NO
Is the thermostat level?	YES	NO
Is the heat anticipator setting correct?	YES	NO

GAS SYSTEM		
Gas Type: (circle one)	Natural Gas	Propane
Gas pipe connections leak tested?	YES	NO
Gas Line Pressure: _____ (in - W.C.)		
Installation Altitude: _____ (FT.)		
Deration Percentage: _____ (%)		
Furnace Input: _____ (Btuh)		
Supply Air Temperature: _____ (° F)		
Return Air Temperature: _____ (° F)		
Temperature Rise: _____ (° F)		

COMBUSTION AIR & VENTING SYSTEM		
Is there adequate fresh air supply for combustion and ventilation?	YES	NO
Vent free from restrictions?	YES	NO
Filter(s) secured in place?	YES	NO
Filter(s) clean?	YES	NO
Flue connections tight?	YES	NO
Is there proper draft?	YES	NO



We Encourage Professionalism



Through Technician Certification by NATE

Specifications & illustrations subject to change without notice or incurring obligations (04/18). O'Fallon, MO, © Nortek Global HVAC LLC 2018. All Rights Reserved.



709404D
(Replaces 709404C)