

INSTALLATION INSTRUCTIONS



*SD Upflow / Horizontal Furnace

⚠ WARNING

FIRE OR EXPLOSION HAZARD

- Failure to follow safety warnings exactly could result in serious injury, death or property damage.
- Installation and service must be performed by a qualified installer, service agency or the gas supplier.
- Do not store or use gasoline or other flammable vapors and liquids in the vicinity of this or any other appliance.

WHAT TO DO IF YOU SMELL GAS

- Do not try to light any appliance.
- Do not touch any electrical switch; do not use any phone in your building.
- Leave the building immediately.
- Immediately call your gas supplier from a neighbors phone. Follow the gas suppliers instructions.
- If you cannot reach your gas supplier, call the fire department.

DO NOT DESTROY. PLEASE READ CAREFULLY & KEEP IN A SAFE PLACE FOR FUTURE REFERENCE.

TABLE OF CONTENTS

IMPORTANT SAFETY INFORMATION.....	3	ELECTRICAL WIRING	19
REQUIREMENTS & CODES	3	Line Voltage Wiring	19
Combustion Air Quality.....	4	Grounding.....	19
Heating Load.....	4	Thermostat / Low Voltage Connections	19
Installation in a Garage	5	Twinning.....	19
Clearances to Combustible Materials.....	5	START-UP & ADJUSTMENTS.....	22
Operation of Furnace During Construction.....	5	Pre-Start Check List	22
COMBUSTION AIR & VENTING REQUIREMENTS	5	Start-up Procedures	22
Direct Vent Furnaces.....	6	Verifying & Adjusting Input Rate.....	22
Conventional Vent Systems - Confined Spaces.....	6	Verifying & Adjusting Temperature Rise	22
Air From Inside	6	Verifying Burner Operation.....	23
Outdoor Air from a Crawl Space or Vented Attic.....	7	Verifying Operation of the Supply Air Limit Switch	23
Outdoor Air Using Vertical Ducts.....	7	CONTROL BOARD FUNCTIONS.....	23
Outdoor Air Using Horizontal Ducts	7	Control Interface.....	23
Air Directly Through An Exterior Wall.....	8	Auto Restart:	23
Alternate Method of Providing Air from Outside	8	Interface Option Menu.....	23
Conventional Vent Systems - Unconfined Spaces.....	8	Reset to Factory Default	23
Category IV Venting	8	Active Alarm Menu	23
Vent Pipe Material.....	8	Last 6 Faults Menu.....	23
Vent Pipe Length & Diameter.....	9	Configuring The Blower.....	25
Vent Pipe Installation.....	9	Selecting Cooling for 1st or 2nd Stage and Blower	
Outdoor Terminations - Horizontal Venting	10	Speed Selection	25
Outdoor Terminations - Vertical Venting	11	Cooling off Delay(COd)	25
Vent Freezing Protection.....	11	Selecting the (Gas) Heating Speed.....	25
Existing Installations.....	11	Selecting Heat Off Delay (HOd)	26
Condensate Disposal	11	Determining Nominal System Capacity.....	26
CIRCULATING AIR REQUIREMENTS.....	12	System Operation.....	26
Plenums & Air Ducts	12	(Gas) Heating Mode or Heat Pump Emergency Heat ..	26
Return Air Connections	12	AC or Heat Pump Cooling Mode.....	26
Upflow & Horizontal Furnaces.....	12	Heat Pump Heating Mode	26
Supply Air Connections.....	12	Heat Pump Heating-Defrost Mode	26
Acoustical Treatments.....	13	Manual Fan	26
FURNACE INSTALLATION.....	13	Selecting Continuous Fan Blower Tap Setting.....	26
General Requirements	13	Fault Conditions	26
Upflow Furnaces	13	Electronic Air Cleaner (EAC).....	26
Horizontal Furnaces	13	Humidifier (HUM).....	26
Inducer & Venting Options	14	OPERATING SEQUENCE.....	26
Inducer Assembly Rotation	14	Heating Cycle.....	26
Pressure Switch Tubing	14	Cooling Cycle	27
Alternate Pressure Switch Location	14	1st Stage Cooling	27
Accessories	15	2nd Stage Cooling.....	27
Finish Flange.....	15	Fan Mode	28
Rubber Grommets.....	15	MAINTENANCE	28
PVC Components.....	15	TROUBLESHOOTING	28
Typical Orientation.....	15	FURNACE COMPONENTS	32
Alternate Orientation.....	16	FIGURES & TABLES.....	33
Optional PVC Pipe Installation	16	Figure 23. *SD Cabinet Dimensions.....	33
Condensate Drain Lines.....	16	Table 8. *SD 050U-T23A* Blower Data	
Bottom Panel Removal.....	17	(Airflow Data)	
GAS SUPPLY & PIPING.....	17	(Heating Airflow)	34
High Altitude	18	Table 9. *SD 050U-T23A* Blower Data	
Leak Check	18	(Cooling Airflow).....	35
Main Burner Gas Orifice.....	19		
Air Inlet Orifice.....	19		

Table 10. *SD 070U-T24B Blower Data (Heating Airflow)	3
Table 11. *SD 070U-T24B* Blower Data (Cooling Airflow).....	37
Table 12. *SD 100U-T35C* Blower Data (Heating Airflow).....	38
Table 13. *SD 100U-T35C* Blower Data (Cooling Airflow).....	3

Electrical Information

Figure 24. *SD Wiring Diagram	40
Figure 25. *SD Ladder Diagram	41

Gas Information

Table 14. Gas Flow Rates.....	42
Table 15. Gas Pipe Capacities.....	42

Venting Information

Table 16. Vent Termination Clearances.....	43
Figure 26. Horizontal & Vertical Venting	44
Figure 27. Venting Options for Upflow Installations	45
Figure 28. Venting Options for 1 Pipe Horizontal Installations.....	46
Figure 29. Venting Options for 2-Pipe Horizontal Installations	47
Figure 30. *SD 050U-T23A* & *070U-T24B* Pressure Switch Tube Locations	48
Figure 31. *SD 100U-T35C* Pressure Switch Tube Locations.....	49

INSTALLATION CHECKLIST.....52

IMPORTANT SAFETY INFORMATION

INSTALLER: Please read all instructions before servicing this equipment. Pay attention to all safety warnings and any other special notes highlighted in the manual. Safety markings are used frequently throughout this manual to designate a degree or level of seriousness and should not be ignored. **WARNING** - Indicates a potentially hazardous situation that if not avoided, could result in personal injury or death. **CAUTION** - Indicates a potentially hazardous situation that if not avoided, may result in minor or moderate injury or property damage.

⚠ WARNING:

The safety information listed in this manual must be followed during the installation, service, and operation of this unit. Unqualified individuals should not attempt to interpret these instructions or install this equipment. Failure to follow safety recommendations could result in possible damage to the equipment, serious personal injury or death.

⚠ WARNING:

Unless otherwise noted in these instructions, only factory authorized kits or accessories may be used with or when modifying this product.

⚠ WARNING:

Improper installation, service, adjustment, or maintenance may cause explosion, fire, electrical shock or other hazardous conditions which may result in personal injury or property damage. Unless otherwise noted in these instructions, only factory authorized kits or accessories may be used with this product.

⚠ WARNING:

Do not install this furnace if any part has been submerged under water. A flood damaged furnace is extremely dangerous. Attempts to use the furnace may result in fire or explosion. A qualified service agency should be contacted to inspect the furnace and to replace any electrical or control system parts that have been wet or under water.

- To minimize equipment failure or personal injury, it is essential that only qualified individuals install, service, or maintain this equipment. If you do not possess mechanical skills or tools, call your local dealer for assistance.
- Follow all precautions in the literature, on tags, and on labels provided with the equipment. Read and thoroughly understand the instructions provided with the equipment prior to performing the installation and operational checkout of the equipment.
- Use caution when handling this appliance or removing components. Personal injury can occur from sharp metal edges present in all sheet metal constructed equipment.
- Do not store any of the following on, or in contact with, the unit: Rags, brooms, vacuum cleaners, or other cleaning tools, spray or aerosol cans, soap powders, bleaches, waxes, cleaning compounds, plastics or plastic containers, paper bags or other paper products, gasoline, kerosene, cigarette lighter fluid, dry cleaning fluids, paint thinners, or other volatile fluids.
- The installer should become familiar with the units wiring and ladder diagram before making any electrical connections to the unit. See Figure 25 (page 41), Figure 26 (page 42), or the units wiring label.
- Always reinstall the doors on the furnace after servicing. Do not operate the furnace without all doors and covers in place.

REQUIREMENTS & CODES

⚠ WARNING:

The information listed below must be followed during the installation, service, and operation of this furnace. Failure to follow safety recommendations could result in possible damage to the equipment, serious personal injury or death.

- This furnace must be installed in accordance with these instructions, all applicable local building codes and the

current revision of the National Fuel Gas Code (NFPA54/ANSI Z223.1).

- Use only with type of gas approved for this furnace. Refer to the furnace rating plate.
- Install this furnace only in a location and position as specified on [page 5](#).
- Provide adequate combustion and ventilation air to the furnace space as specified on [page 5](#), [page 7](#) & [page 8](#).
- Provide adequate clearances around the vent air intake terminal as shown in [Figure 7 \(page 10\)](#), [Figure 8 \(page 10\)](#), [Figure 9 \(page 10\)](#), & [Figure 10 \(page 11\)](#).
- Combustion products must be discharged outdoors. Connect this furnace to an approved vent system only, as specified on [page 8](#), [page 9](#), & [page 11](#).
- Never test for gas leaks with an open flame. Use a commercially available soap solution to check all connections. See [page 18](#).
- This furnace is designed to operate with a maximum external pressure rise of 0.5 inches of water column. Consult [Table 8 \(page 35\)](#), [Table 9 \(page 36\)](#), [Table 10 \(page 37\)](#), [Table 11 \(page 38\)](#), [Table 12 \(page 39\)](#), & [Table 13 \(page 40\)](#) and the rating plate for the proper circulating air flow and temperature rise. It is important that the duct system be designed to provide the correct flow rates and external pressure rise. An improperly designed duct system can result in nuisance shutdowns, and comfort or noise issues.
- When supply ducts carry air circulated by the furnace to areas outside the space containing the furnace, the return air shall also be handled by duct(s) sealed to the furnace casing and terminating in the conditioned space. See [page 12](#).
- A gas-fired furnace for installation in a residential garage must be installed as specified on [page 5](#).
- This furnace is not approved for installation in mobile homes. Installing this furnace in a mobile home could cause fire, property damage, and/or personal injury.

The information listed below is for reference purposes only and does not necessarily have jurisdiction over local or state codes. Always consult with local authorities before installing any gas appliance.

Combustion & Ventilation Air

- US: National Fuel Gas Code (NFGC), Air for Combustion and Ventilation

Duct Systems

- Air Conditioning Contractors Association (ACCA) Manual D, Sheet Metal and Air Conditioning Contractors National Association (SMACNA), or American Society of Heating, Refrigeration, and Air Conditioning Engineers (ASHRAE) Fundamentals Handbook

Electrical Connections

- US: National Electrical Code (NEC) ANSI/NFPA 70

Gas Piping & Gas Pipe Pressure Testing

- US: NFGC and National Plumbing Codes

General Installation

- US: Current edition of the NFGC and the NFPA 90B. For copies, contact the National Fire Protection Association Inc., Batterymarch Park, Quincy, MA 02269; or American Gas Association, 400 N. Capitol, N.W., Washington DC 20001 or www.NFPA.org

Safety

- US: (NFGC) NFPA 54–1999/ANSI Z223.1 and the Installation Standards, Warm Air Heating and Air Conditioning Systems ANSI/NFPA 90B.

Combustion Air Quality

CAUTION:

Combustion air must not be drawn from a corrosive atmosphere.

To maximize heat exchanger life, the combustion air must be free of chemicals that can form corrosive acidic compounds in the combustion gases. The recommended source of combustion air is to use outdoor air. However, the use of indoor air in most applications is acceptable except as listed:

- If the furnace is installed as a single pipe installation in a confined space, it is required that the necessary combustion air come from the outdoors by way of attic, crawl space, air duct, or direct opening. For Installations in confined spaces, see [page 6](#) for combustion air requirements.
- Installations in these locations may require outdoor air for combustion, due to chemical exposures:
 - Commercial buildings
 - Buildings with indoor pools
 - Furnaces installed in laundry rooms
 - Furnaces installed in hobby or craft rooms
 - Furnaces installed near chemical storage areas
- Exposure to the following substances in the combustion air supply may require outdoor air for combustion:
 - Permanent wave solutions
 - Chlorinated waxes and cleaners
 - Chlorine based swimming pool chemicals
 - Water softening chemicals
 - De-icing salts or chemicals
 - Carbon Tetrachloride
 - Halogen type refrigerants
 - Cleaning solvents (perchloroethylene)
 - Printing inks, paint removers, varnishes, etc.
 - Hydrochloric Acid
 - Cements and glues
 - Antistatic fabric softeners
 - Masonry acid washing materials

Heating Load

This furnace should be sized to provide the design heating load requirement. Heating load estimates can be made using approved methods available from Air Conditioning Contractors of America (Manual J); American Society of Heating, Refrigerating, and Air Conditioning Engineers; or other approved engineering methods. **Excessive oversizing of the furnace could cause the furnace and/or vent to fail prematurely.**

The ductwork should be appropriately sized to the capacity of the furnace to ensure its proper airflow rating. For installations above 2,000 ft., the furnace should have a sea level input rating large enough that it will meet the heating load after deration for altitude.

⚠ WARNING:

Do not place combustible material on or against the furnace cabinet or within 6 inches of the vent pipe. Do not place combustible materials, including gasoline or any other flammable vapors and liquids, in the vicinity of the furnace.

This gas-fired furnace may be installed in a residential garage with the provision that the igniter is located no less than 18 inches (457mm) above the floor. The furnace must be located or protected to prevent physical damage by vehicles.

Clearances to Combustible Materials

This furnace is Design Certified in the U.S. for the minimum clearances to combustible materials. **NOTE:** The furnace is listed for installation on combustible or non-combustible flooring. However, wood is the only combustible flooring allowed for installation. To obtain model number and specific clearance information, refer to the furnace rating plate, located inside of the furnace cabinet.

Access for positioning and servicing the unit must be considered when locating unit. The need to provide clearance for access to panels or doors may require clearance distances over and above the requirements. **Allow 24 inches minimum clearance from the front of the unit. However 36 inches is strongly recommended.** See Figure 1 for minimum clearance requirements.

Operation of Furnace During Construction

⚠ CAUTION:

Operating gas furnaces in construction environments can cause a variety of problems within the furnace and may significantly reduce the life or the performance of the furnace. Therefore operating the furnace during construction is not permitted and will void the warranty.

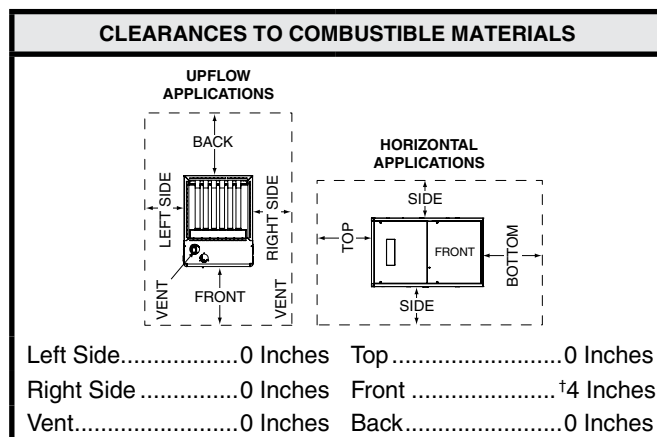

†Allow 24 in. minimum clearance for servicing. Recommended clearance is 36 in.

Figure 1. Minimum Clearances to Combustible Materials

⚠ WARNING:

CARBON MONOXIDE POISONING HAZARD
Failure to follow the steps outlined below for each appliance connected to the venting system being placed into operation could result in carbon monoxide poisoning or death.

The following steps shall be followed with each individual appliance connected to the venting system being placed in operation, while all other appliances connected to the venting system are not in operation:

1. Seal any unused openings in the venting system.
2. Inspect the venting system for proper size and horizontal pitch, as required in the National Fuel Gas Code, ANSI Z223.1/NFPA 54 and these instructions. Determine that there is no blockage or restriction, leakage, corrosion and other deficiencies which could cause an unsafe condition.
3. As far as practical, close all building doors and windows and all doors between the space in which the appliance(s) connected to the venting system are located and other spaces of the building.
4. Close fireplace dampers.
5. Turn on clothes dryers and any appliance not connected to the venting system. Turn on any exhaust fans, such as range hoods and bathroom exhausts, so they are operating at maximum speed. Do not operate a summer exhaust fan.
6. Follow the lighting instructions. Place the appliance being inspected into operation. Adjust the thermostat so appliance is operating continuously.
7. Test for spillage from draft hood equipped appliances at the draft hood relief opening after 5 minutes of main burner operation. Use the flame of a match or candle.
8. If improper venting is observed during any of the above tests, the venting system must be corrected in accordance with the National Fuel Gas Code, ANSI Z223.1/NFPA 54 and/or CSA B149.1, Natural Gas and Propane Installation Codes.
9. After it has been determined that each appliance connected to the venting system properly vents when tested as outlined above, return doors, windows, exhaust fans, fireplace dampers and any other gas-fired burning appliance to their previous conditions of use.

IMPORTANT INFORMATION:

- This furnace must be vented in compliance with the current revision of the National Fuel Gas Code (ANSI-Z223.1/NFPA54). Instructions for determining the adequacy of an installation can be found in the current revision of the NFGC (ANSI Z223.1 / NFPA54). Refer to the NFGC for approved vent tables. Consult local codes for special requirements. These requirements are for US installations as found in the NFGC.
- Furnace installation using methods other than those described in the following sections must comply with the National Fuel Gas Code (NFGC) and all applicable local codes.
- Provisions must be made during the installation of this furnace that provide an adequate supply of air for combustion. The combustion air from the outside needs to be clear of chemicals that can cause corrosion. The inlet pipe should not be placed near corrosive chemicals such as those listed on [page 4](#).

WARNING:

Upon completion of the furnace installation, carefully inspect the entire flue system both inside and outside the furnace to assure it is properly sealed. Leaks in the flue system can result in serious personal injury or death due to exposure of flue products, including carbon monoxide.

WARNING:

This furnace must not be vented with other appliances, even if that appliance is of the condensing type. Common venting can result in severe corrosion of other appliances or their venting and can allow combustion gases to escape through such appliances or vents. Do not vent the furnace to a fireplace chimney or building chase.

This condensing furnace is certified for installation either as a Direct Vent (2-pipe) or Conventional (1-pipe) appliance. Direct Vent appliances draw combustion air from the outdoors and vent combustion products back outside. Installation with air taken from around the furnace is often referred to as Conventional installation - i.e. only the vent (exhaust) pipe is provided.

Another important consideration when selecting one or two pipe installation is the quality of the Indoor air which can sometimes be contaminated with various household chemicals. These chemicals can cause severe corrosion in the furnace combustion system. A 2-pipe installation has the additional advantage that it isolates the system from the effects of negative pressure in the house.

CAUTION:

Exhaust fans, clothes dryers, fireplaces and other appliances that force air from the house to the outdoors can create a negative pressure inside the house, resulting in improper furnace operation or unsafe conditions such as flame roll out. It is imperative that sufficient air exchange with the outdoors is provided to prevent depressurization. Additional information about how to test for negative pressure problems can be found in the NFGC.

IMPORTANT NOTE

Air openings on top of the furnace and openings in closet doors or walls must never be restricted. If the furnace is operated without adequate air for combustion, a pressure switch will open and will not allow the furnace to operate.

DO NOT install jumper wires across this switch to defeat its function or reset a switch without identifying and correcting the fault condition. If a switch must be replaced, use only the correct sized part specified in the Replacement Parts List provided online.

Direct Vent Furnaces

Direct Vent (2-pipe) furnaces draw combustion air directly from the outdoors and then vent the combustion products back outside, isolating the entire system from the indoor space. It is important to make sure that the whole system is sealed and clearances to combustibles are maintained regardless of the installation being in a confined or unconfined space.

Conventional Vent Systems - Confined Spaces

A confined space is an area with volume less than 50 cubic feet per 1,000 Btuh of the combined input rates of all appliances drawing combustion air from that space. Furnace closets, small equipment rooms and garages are confined spaces. Furnaces installed in a confined space which supply heated air to areas outside the space must draw return air from outside the space and must have the return air ducts tightly sealed to the furnace. Ducts must have cross-sectional area at least as large as the free area of their respective openings to the furnace space. Attics or crawl spaces must connect freely with the outdoors if they are the source of air for combustion and ventilation.

The required sizing of these openings is determined by whether inside or outside air is used to support combustion, the method by which the air is brought to the space, and by the total input rate of all appliances in the space. In all cases, the minimum dimension of any combustion air opening is 3 inches.

Air From Inside

If combustion air is taken from the heated space, the two openings must each have a free area of at least one square inch per 1,000 Btuh of total input of all appliances in the confined space, but **not less than** 100 square inches of free area. See [Example](#) and [Figure 2 \(page 7\)](#).

EXAMPLE

If the combined input rate of all appliances is less than or equal to 100,000 Btuh, each opening must have a free area of at least 100 in². If the combined input rate of all appliances is 120,000 Btuh, each opening must have a free area of at least 120 in².

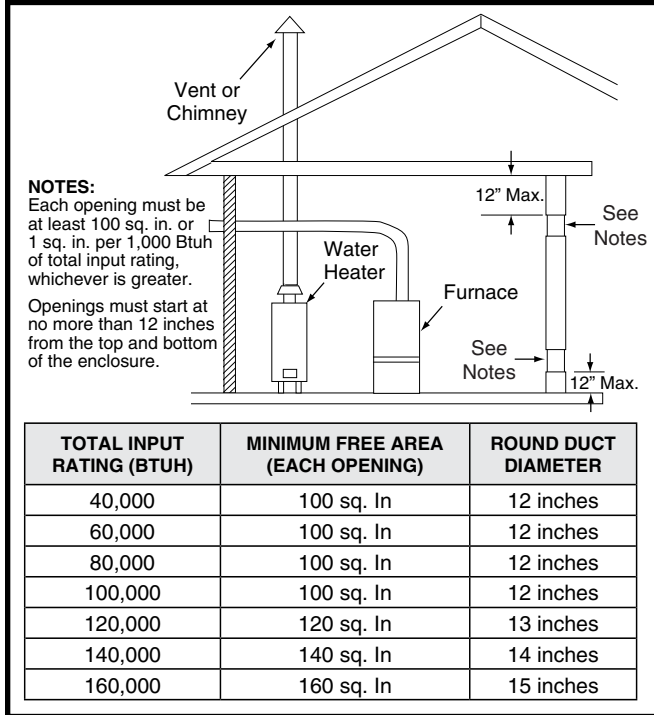

Figure 2. Combustion Air Drawn from Inside

Outdoor Air from a Crawl Space or Vented Attic

When the openings can freely exchange air with the outdoors, each opening shall have a minimum free area of 1 square inch per 4,000 Btuh of total appliance input. The openings shall exchange directly, or by ducts, with the outdoor spaces (crawl or attic) that freely exchange with the outdoors. See Figure 3.

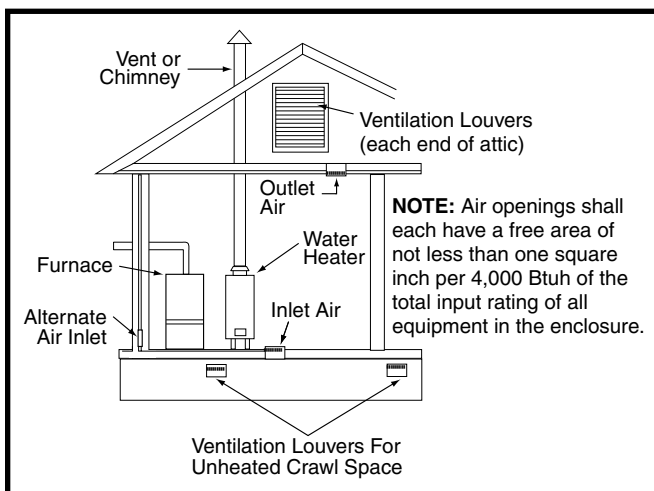

Figure 3. Combustion Air Drawn from a Crawl Space or Vented Attic

Outdoor Air Using Vertical Ducts

If combustion air is taken from outdoors through vertical ducts, the openings and ducts must have a minimum free area of one square inch per 4,000 Btuh of total appliance input. See Figure 4.

Outdoor Air Using Horizontal Ducts

If combustion air is taken from outdoors through horizontal ducts, the openings and ducts must have a minimum free area of one square inch per 2,000 Btuh of total appliance input. Ducts must have cross-sectional area at least as large as the free area of their respective openings to the furnace space. See Figure 5.

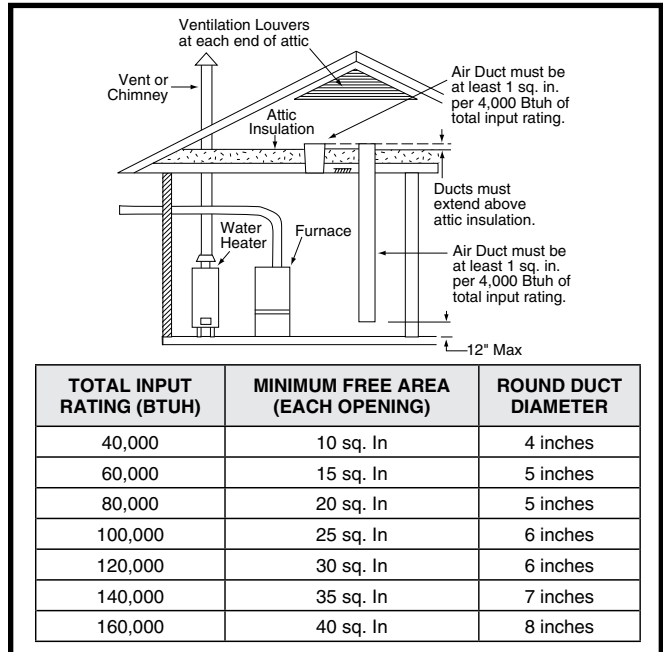

Figure 4. Combustion Air Drawn from Outside Through Vertical Ducts

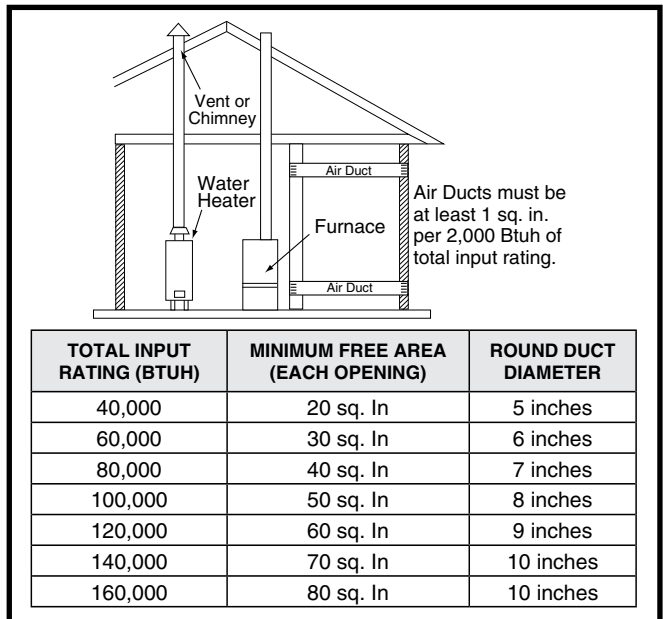

Figure 5. Combustion Air Drawn from Outside Through Horizontal Ducts

Air Directly Through An Exterior Wall

If combustion air is provided directly through an exterior wall, the two openings must each have free area of at least one square inch per 4,000 Btuh of total appliance input. See [Figure 6](#).

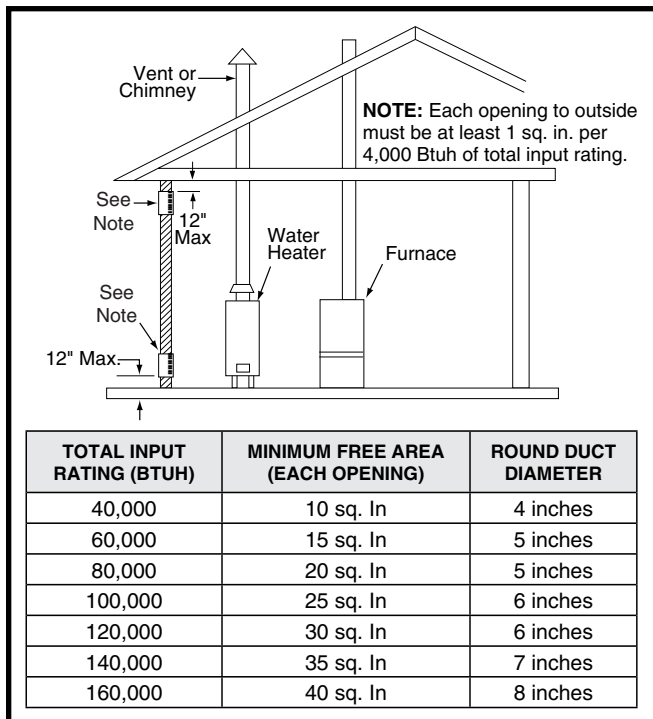

Figure 6. Combustion Air Drawn from Outside Through an Exterior Wall

Alternate Method of Providing Air from Outside

If acceptable under local Codes, it is permitted to provide outside air using one opening (See NFGC). Generally, confined spaces must have two openings in the space for combustion air. One opening must be within 12 inches of the ceiling, and the other must be within 12 inches of the floor. However, an alternative method recently adopted by the NFGC uses one opening within 12 inches of the top of the space. This method may be used if it is acceptable to the local codes.

THE FOLLOWING CONDITIONS MUST BE MET:

1. The opening must start within 12" of the top of the structure and connect with the out of doors through vertical or horizontal ducts or be ducted to a crawl or attic space that connects with the out of doors.
2. The opening must have a minimum free area of 1 sq. in. per 3,000 Btu per hour of the total input rating of all equipment located in the enclosure.
3. The free area must not be less than the sum of all the areas of the vent connectors in the enclosure.

Conventional Vent Systems - Unconfined Spaces

An unconfined space is an area including all rooms not separated by doors with a volume greater than 50 cubic feet per 1,000 Btuh of the combined input rates of all appliances which draw combustion air from that space.

In general, a furnace installed in an unconfined space will not require outside air for combustion. However, in homes built for energy efficiency (low air change rates), it may be necessary to provide outside air to ensure adequate combustion and venting, even though the furnace is located in an unconfined space. See [Example](#) below.

EXAMPLE

A space with a water heater rated at 45,000 Btuh input and a furnace rated at 75,000 Btuh requires a volume of 6,000 cubic feet [$50 \times (45 + 75) = 6,000$] to be considered unconfined. If the space has an 8 foot ceiling, the floor area of the space must be 750 sq. ft. ($6,000 / 8 = 750$).

Category IV Venting

⚠ WARNING:

Upon completion of the furnace installation, carefully inspect the entire flue system both inside and outside the furnace to assure it is properly sealed. Leaks in the flue system can result in serious personal injury or death due to exposure of flue products, including carbon monoxide.

This furnace is classified as a "Category IV" appliance, which requires special venting materials and installation procedures. This section specifies installation requirements for Conventional (1-pipe) and Direct Vent (2-pipe) piping.

For 1- pipe installations, install vent piping as described in this section and provide air for combustion and ventilation according to [page 5](#), [page 6](#), [page 7](#) & [page 8](#). The length of vent and combustion air piping for either type of installation are listed in [Table 1 \(page 9\)](#).

Category IV appliances operate with positive vent pressure and therefore require vent systems which are thoroughly sealed. They also produce liquid condensate, which is slightly acidic and can cause severe corrosion of ordinary venting materials. Furnace operation can be adversely affected by restrictive vent and combustion air piping.

The inducer assembly on this furnace can be rotated to vent the flue products out of the top, left or right side. This increases the flexibility of which direction the vent pipe can exit the furnace.

Vent Pipe Material

Vent and combustion air pipe and fittings must be one of the following materials in the list and must conform to the indicated ANSI/ASTM standards.

MATERIALS	STANDARDS
Schedule 40PVC	D1785
CPVC.....	D1784
PVC-DWV.....	D2665
SDR-21 & SDR-26.....	D2241
ABS-DWV.....	D2661
Schedule 40 ABS	F628
Foam / Cellular Core PVC.....	F891
*PolyPro® by DuraVent.....	ULC-S636
CPVC.....	D1784

*When using PolyPro®, all venting and fittings must be from the same manufacturer with no interchanging of other materials. Refer to specific instructions supplied with the PolyPro vent kits

When joining PVC to PVC, use cement that conforms to ASTM standard D2564. PVC primer must meet standard ASTM F656. When joining ABS to ABS, use cement that conforms to ASTM standard D2235. When joining PVC to ABS, use cement as specified in procedure from ASTM standard D3138

Vent Pipe Length & Diameter

In order for the furnace to operate properly, the combustion air and vent piping must not be excessively restrictive.

- The venting system should be designed to have the minimum number of elbows or turns.
- Transition to the final vent diameter should be done as close to the furnace outlet as practical.
- Always use the same size or a larger pipe for combustion air that is used for the exhaust vent.

Table 1 indicates the maximum allowable pipe length for a furnace of known input rate, when installed with piping of selected diameter and number of elbows. To use the table, the furnace input rate, the centerline length and the number of elbows on each pipe must be known.

When estimating the length of vent runs, consideration must be made to the effect of elbows and other fittings. This is conveniently handled using the idea of “equivalent length”. This means the fittings are assigned a linear length that accounts for the pressure drop they will cause. For example: a 2” diameter, long radius elbow is worth the equivalent of 2.5 feet of linear run. A 90 degree tee is worth 7 ft.

The equivalent lengths of tees and various elbows are listed in Table 1. Measure the linear length of your vent run and then add in the equivalent length of each fitting. The total

length, including the equivalent fitting lengths, must be less than the maximum length specified in the table.

Vent Pipe Installation



Combustion air must not be drawn from a corrosive atmosphere.

This furnace has been certified for installation with zero clearance between vent piping and combustible surfaces. However, it is good practice to allow space for convenience in installation and service.

- In the absence of local codes, the location of any combustion air inlet relative to any vent terminal must be at least 8 inches. This includes installations involving more than one furnace.
- The quality of outdoor air must also be considered. Be sure that the combustion air intake is not located near a source of solvent fumes or other chemicals which can cause corrosion of the furnace combustion system. (See page 4 for a sample list of substances).
- Route piping as direct as possible between the furnace and the outdoors. Horizontal piping from inducer to the flue pipe must be sloped 1/4” per foot to ensure condensate flows towards the drain tee or PVC trap. Longer vent runs require larger pipe diameters. Refer to the Inducer & Venting Options section on page 14 for additional information.
- If a Direct Vent (2-pipe) system is used, the combustion air intake and the vent exhaust must be located in the same atmospheric pressure zone. This means both pipes must exit the building through the same portion of exterior wall or roof as shown in Figure 27 (page 45).
- Piping must be mechanically supported so that its weight does not bear on the furnace. Pipe supports must be installed a minimum of every five feet along the vent run to ensure no displacement after installation. Supports may be at shorter intervals if necessary to ensure that there are no sagging sections that can trap condensate. It is recommended to install couplings along the vent pipe, on either side of the exterior wall (Figure 27). These couplings may be required by local code.

FURNACE MODELS (BTU)	FURNACE INSTALLATION	SINGLE VENT PIPE LENGTH (FT.) WITH 1 LONG RADIUS ELBOW†		DUAL VENT PIPE LENGTH (FT.) WITH 1 LONG RADIUS ELBOW ON EACH PIPE†	
		OUTLET 2” DIAMETER	OUTLET 3” DIAMETER	INLET / OUTLET 2” DIAMETER	INLET / OUTLET 3” DIAMETER
50,000	Upflow	90	90	90	90
	Horizontal	90	90	90	90
70,000	Upflow	60	90	60	90
	Horizontal	60	90	60	90
100,000	Upflow	40	90	40	90
	Horizontal	40	90	40	90

†NOTES:

1. Subtract 2.5 ft. for each additional 2 inch long radius elbow, 5 ft. for each additional 2 inch short radius elbow, 3.5 ft. for each additional 3 inch long radius elbow, and 7 ft. for each additional 3 inch short radius elbow. Subtract 5 ft for each 2” tee and 8 ft for each 3” tee.
2. Two 45 degree elbows are equivalent to one 90 degree elbow.
3. This table applies for elevations from sea level to 2,000 ft. For higher elevations, decrease pipe lengths by 8% per 1,000 ft of altitude.
4. A long radius elbow’s centerline radius is equal to or greater than 1.5 times the vent diameter.

Table 1. Vent Pipe Lengths

- If breakable connections are required in the combustion air inlet pipe (if present) and exhaust vent piping, then straight neoprene couplings for 2" or 3" piping with hose clamps can be used. These couplings can be ordered through your local furnace distributor. To install a coupling:

1. Slide the rubber coupling over the end of the pipe that is attached to the furnace and secure it with one of the hose clamps.
2. Slide the other end of the rubber coupling onto the other pipe from the vent.
3. Secure the coupling with the second hose clamp, ensuring that the connection is tight and leak free.

Outdoor Terminations - Horizontal Venting

- Vent and combustion air intake terminations shall be installed as shown in [Figure 7](#) & [Figure 8](#) and in accordance with these instructions:

- Vent termination clearances must be consistent with the NFPA, ANSI 2223.1/NFPA 54. [Table 16 \(page 44\)](#) lists the necessary distances from the vent termination to windows and building air intakes.

- Vent and combustion air intake terminations must be located to ensure proper furnace operation and conformance to applicable codes. A vent terminal must be located at least 3 feet above any forced air inlet located within 10 feet. This does not apply to the combustion air inlet of a direct vent (two pipe) appliance. See [Table 16 \(page 44\)](#).

- All minimum clearances must be maintained to protect building materials from degradation by flue gases. See [\(Figure 8\)](#).

- For optimal performance, vent the furnace through a wall that experiences the least exposure to winter winds.

- The vent termination shall be located at least 3 ft. horizontally from any electric meter, gas meter, regulator and any relief equipment. These distances apply ONLY to U.S. installations.

- Do not install the vent terminal such that exhaust is directed into window wells, stairwells, under decks or into alcoves or similar recessed areas, and do not terminate above any public walkways.

- If venting horizontally, a side wall vent kit is available according to the pipe diameter size of the installation. For 2 inch pipe use side wall vent kit #904617, and for 3 inch pipe use kit #904347. **Please follow the instructions provided with the kit.**

- Concentric vent termination kits are available for use with these furnaces. Refer to the technical sales literature for kit numbers.

2 Inch pipe: U.S. use kit #904177
3 inch pipe: U.S. use kit # 904176

- When the vent pipe must exit an exterior wall close to the grade or expected snow level where it is not possible to obtain clearances shown in [Figure 7](#), a riser may be provided as shown in [Figure 9](#). Insulation is required to prevent freezing of this section of pipe. See [Table 2 \(page 11\)](#) for vent freezing protection.

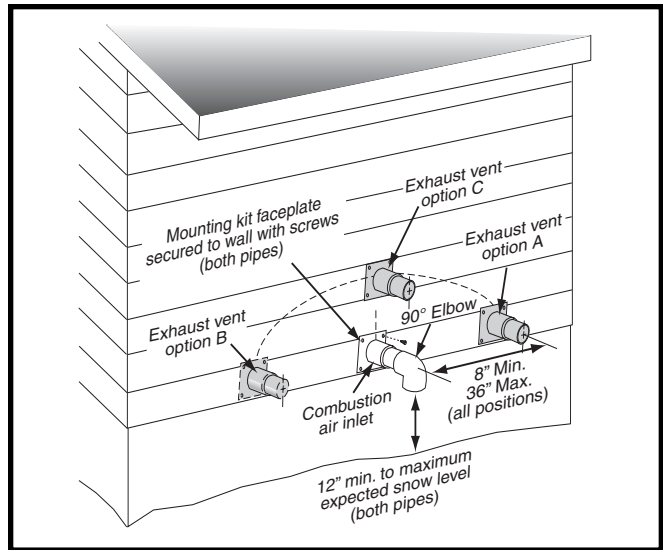
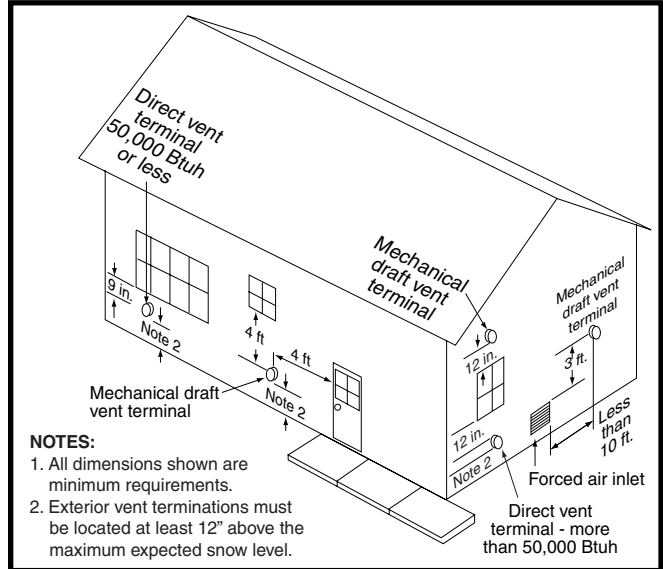

Figure 7. Inlet & Exhaust Pipe Clearances



NOTES:

1. All dimensions shown are minimum requirements.
2. Exterior vent terminations must be located at least 12" above the maximum expected snow level.

Figure 8. Vent Locations

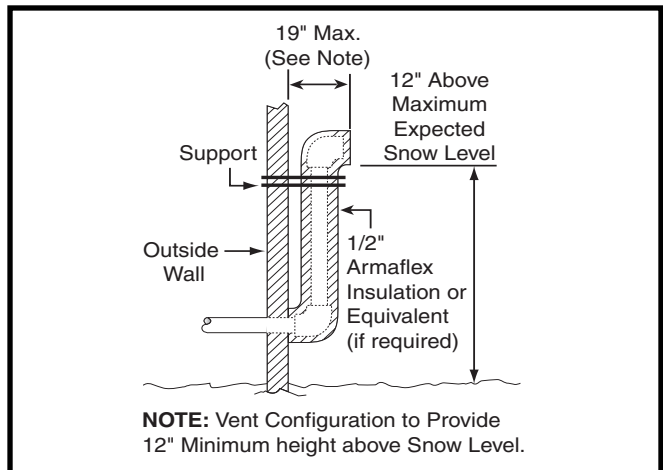

Figure 9. Alternate Horizontal Vent Installation

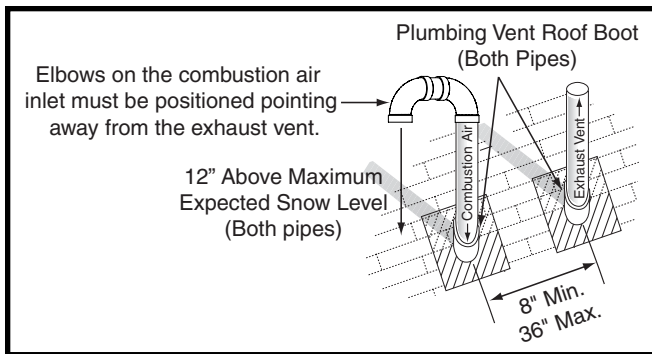

Figure 10. Vertical Vent Termination

Outdoor Terminations - Vertical Venting

Termination spacing requirements from the roof and from each other are shown in Figure 10. The roof penetration must be properly flashed and waterproofed with a plumbing roof boot or equivalent flashing. Vent and combustion air piping may be installed in an existing chimney which is not in use provided that:

- Both the exhaust vent and air intake run the length of the chimney.
- The top of the chimney is sealed and weatherproofed.
- The termination clearances shown in Figure 10 are maintained.
- No other gas fired or fuel-burning equipment is vented through the chimney.

Vent Freezing Protection

CAUTION:

When the vent pipe is exposed to temperatures below freezing (i.e., when it passes through unheated spaces, chimneys, etc.) the pipe must be insulated with 1/2 inch thick sponge rubber insulation, Armaflex-type insulation or equivalent. Insulating pipe is important to avoid condensate icing.

- Table 2 lists the maximum length of flue pipe that can travel through an unconditioned space or an exterior space. The total vent length must not exceed the lengths noted in Table 1 (page 9).
- For extremely cold climates or for conditions of short furnace cycles (i.e. set back thermostat conditions) the last 18 inches of vent pipe can be reduced. It is acceptable to reduce from 3" to 2-1/2", 3" to 2", or 2" to 1-1/2" if the total vent length is at least 15 feet in length, and the vent length is within the parameters specified in Table 1. The restriction should be counted as 3 equivalent feet. Smaller vent pipes are less susceptible to freezing, but must not be excessively restrictive. The length of the 2 inch pipe must not be longer than 18 inches.
- If furnace is installed horizontally, make sure the drainage port on the in-line drain assembly is pointed downward to ensure proper drainage of condensate. See Figure 29 (page 47) & Figure 30 (page 48).
- To prevent debris or creatures from entering the combustion system, a protective screen may be installed over the combustion air intake opening. The screens hole size must be large enough to prevent air restriction.

WINTER DESIGN TEMPERATURE	MAXIMUM FLUE PIPE LENGTH (FEET) IN UNCONDITIONED & EXTERIOR SPACES	
	WITHOUT INSULATION	WITH INSULATION*
20	45	70
0	20	70
-20	10	60

*NOTE: Insulation thickness greater than 3/8 inch, based on an R value of 3.5 (ft x F x hr) / (BTU x in.)

Table 2. Vent Protection

Existing Installations

When an existing furnace is removed from a vent system serving other appliances, the existing vent system may not be sized properly to vent the remaining appliances (For example: water heater). An improperly sized venting system can result in the formation of condensate, leakage, or spillage. The existing vent system should be checked to make sure it is in compliance with NFGC and must be brought into compliance before installing the furnace.

NOTE: If replacing an existing furnace, it is possible you will encounter an existing plastic venting system that is subject to a Consumer Product Safety Commission recall. The pipes involved in the recall are High Temperature Plastic Vent (HTPV). **If your venting system contains these pipes DO NOT reuse this venting system!** This recall does not apply to other plastic vent pipes, such as white PVC or CPVC. Check for details on the CPSC website or call their toll-free number (800) 758-3688.

Condensate Disposal

The method for disposing of condensate varies according to local codes. Consult your local code or authority having jurisdiction. Neutralizer kit P/N 902377 is available for use with this furnace. **Please follow the instructions provided with the kit.**

This furnace has multiple options for positioning the vent pipe as described in the, Vent and Inducer Assembly Options section (page 14). Each of the condensate drain lines must be J-trapped using field supplied parts. After the condensate lines are J-trapped, they may be combined together when routed to the drain.

For Installations where there is limited clearance for the J-Trap (such as an attic where it may be installed between ceiling joists), either side of the J-Trap can be shortened to a minimum of 3 Inches. See Figure 11 (page 13).

CIRCULATING AIR REQUIREMENTS

WARNING:

Do not allow combustion products to enter the circulating air supply. Failure to prevent the circulation of combustion products into the living space can create potentially hazardous conditions including carbon monoxide poisoning that could result in personal injury or death.

All return ductwork must be secured to the furnace with sheet metal screws. For installations in confined spaces, all return ductwork must be adequately sealed. When return air is provided through the bottom of the furnace, the joint between the furnace and the return air plenum must be air tight.

The surface that the furnace is mounted on must provide sound physical support of the furnace with no gaps, cracks or sagging between the furnace and the floor or platform.

Return air and circulating air ductwork must not be connected to any other heat producing device such as a fireplace insert, stove, etc. This may result in fire, explosion, carbon monoxide poisoning, personal injury, or property damage.

Plenums & Air Ducts

- Plenums and air ducts must be installed in accordance with the Standard for the Installation of Air Conditioning and Ventilating Systems (NFPA No. 90A) or the Standard for the Installation of Warm Air Heating and Air Conditioning Systems (NFPA No. 90B).
- [Table 8 \(page 35\)](#), [Table 9 \(page 36\)](#), [Table 10 \(page 37\)](#), [Table 11 \(page 38\)](#), [Table 12 \(page 39\)](#), & [Table 13 \(page 40\)](#) contain the maximum airflow and temperature rise data for each furnace input rate. If the maximum airflow is 1,600 CFM or more, it is recommended that two openings be used for return air on upflow furnaces.
- It is recommended that the outlet duct contain a removable access panel. The opening should be accessible when the furnace is installed in service and shall be of a size that smoke or reflected light may be observed inside the casing to indicate the presence of leaks in the heat exchanger. The cover for the opening shall be attached in a way that prevent leaks.
- If outside air is used as return air to the furnace for ventilation or to improve indoor air quality, the system must be designed so that the return air is not less than 60° F (15° C) during operation. If a combination of indoor and outdoor air is used, the ducts and damper system must be designed so that the return air supply to the furnace is equal to the return air supply under normal, indoor return air applications.
- When a cooling system is installed which uses the furnace blower to provide airflow over the indoor coil, the coil must be installed downstream (on the outlet side) of the furnace or in parallel with the furnace.

- If a cooling system is installed in parallel with the furnace, a damper must be installed to prevent chilled air from entering the furnace and condensing on the heat exchanger. If a manually operated damper is installed, it must be designed so that operation of the furnace is prevented when the damper is in the cooling position and operation of the cooling system is prevented when the damper is in the heating position.
- Seal all connections and joints with industrial grade sealing tape or liquid sealant. Requirements for sealing ductwork vary from region to region. Consult with local codes for requirements specific to your area.

Return Air Connections

- In applications where the supply ducts carry heated air to areas outside the space where the furnace is installed, the return air must be delivered to the furnace by duct(s) secured to the furnace casing, running full size and without interruption. **Do not use the back of the furnace for return air.**
- Position the furnace with the return air ductwork ensuring even alignment of furnace (or coil casing) air opening and return air duct. **NOTE:** The ductwork must have an opening equal to that of the return air opening of the furnace (or coil casing). See [Figure 24 \(page 34\)](#) for return air opening size.

Upflow & Horizontal Furnaces

- The return air ductwork may be connected to the left side, right side, or bottom of the furnace. **NOTE:** If using the left or right side of the furnace for return air, the bottom panel ([Figure 24](#)) must not be removed from the bottom of the furnace.

WARNING:

The bottom panel of the furnace must be in place when the furnace is installed with side return air ducts. Removal of all or part of the base could cause circulation of combustible products into the living space and create potentially hazardous conditions, including carbon monoxide poisoning that could result in personal injury or death.

- **Side Return Installations:** To attach the return air duct to the left or right side of the furnace, punch out the 4 knockouts from the side of the furnace ([Figure 24](#)). Using sharp metal cutters, cut an opening between all 4 knockouts to expose the blower assembly. Position the return air duct over the opening and secure to the side with sheet metal screws.
- **Bottom Return Installations:** If using the bottom of the furnace for return air, the bottom panel ([Figure 24](#)) must be removed from the bottom of the furnace. See [page 17](#) for removal instructions. Position the furnace over the return air duct and secure together with sheet metal screws. Make sure the screws penetrate the duct and furnace casing.

Supply Air Connections

- The supply air must be delivered to the heated space by duct(s) secured to the furnace or coil box casing, running full size and without interruption.

- To attach the supply air duct to upflow & horizontal furnaces, bend the flanges on the furnace upward 90° with wide duct pliers. See [Figure 24](#) for furnace flange locations. **NOTE:** If system installation includes AC coil casing, bend the flanges on the coil casing upward 90° before attaching the supply air duct.
- Position the supply air ductwork onto the furnace ensuring even alignment of furnace air opening and supply air duct. **NOTE:** The ductwork must have an opening equal to that of the supply air opening of the furnace. See [Figure 24 \(page 34\)](#) for supply air opening size.

Acoustical Treatments

Damping ducts, flexible vibration isolators, or pleated media-style filters on the return air inlet of the furnace may be used to reduce the transmission of equipment noise emanating from the furnace. These treatments can produce a quieter installation, particularly in the heated space. However, they can increase the pressure drop in the duct system. Care must be taken to maintain the proper maximum pressure rise across the furnace, temperature rise and flow rate. This may mean increasing the duct size and/or reducing the blower speed. These treatments must be constructed and installed in accordance with NFPA and SMACNA construction standards. Consult with local codes for special requirements. For best sound performance, install all the needed gaskets and grommets around penetrations into the furnace, such as for electrical wiring.

FURNACE INSTALLATION

*SD series gas furnaces offer a wide range of installation options, including installation in the upflow or horizontal positions with either right, left, or upflow return air.

General Requirements

- The furnace must be leveled at installation and attached to a properly installed duct system. See [Figure 1 \(page 5\)](#) for the required clearances needed to move the furnace to its installation point (hallways, doorways, stairs, etc).
- The furnace must be installed so that all electrical components are protected from water.
- The furnace must be installed upstream from a refrigeration system. (If applicable)
- The cabinet plug must always be used to close the hole in the side of the furnace when rotating the inducer.
- The furnace requires special venting materials and installation procedures. See [page 5](#), [page 6](#), [page 7](#), [page 8](#), [page 9](#), & [page 11](#) for venting guidelines and specifications.

Upflow Furnaces

⚠ WARNING:

The furnace must not be installed directly on carpeting, tile, or any combustible material other than wood flooring.

*SD series gas furnaces are shipped with the bottom panel installed as shown in [Figure 24 \(page 34\)](#). If the furnace is installed with only side return air, the bottom panel must not be removed. If the furnace is installed with bottom return air, the bottom panel must be removed. See [Bottom Panel Removal](#) on [page 17](#).

Horizontal Furnaces

⚠ WARNING:

The furnace must not be installed directly on carpeting, tile, or any combustible material other than wood flooring.

*SD series gas furnaces can be installed horizontally ([Figure 11](#)) in an attic, basement, crawl space or alcove. It can also be suspended from a ceiling in a basement or utility room in either a right to left airflow or left to right airflow as shown in [Figure 12 \(page 14\)](#).

These furnaces are shipped with the bottom panel installed. If the furnace is installed horizontally, remove the bottom panel from the furnace before attaching the duct system. See [Bottom Panel Removal](#) on [page 17](#).

If installing the furnace with an evaporator coil (in an attic), it is required that a drip pan be placed under the furnace. If the installation is on a combustible platform as shown in [Figure 11](#), it is recommended that the drip pan extend at least 12 inches past the top and front of the furnace.

NOTE: Although it is not required to use a drip pan for heat only applications, state and local codes may require it.

If suspending the furnace from the ceiling, assemble a support frame ([Figure 12](#)) using slotted iron channel and full threaded rod. Fasten the frame together with nuts, washers, and lockwashers. Secure the support frame to the rafters with lag bolts. The furnace can also be suspended using steel straps around each end of the furnace. The straps should be attached to the furnace with sheet metal screws and to the rafters with bolts.

It is recommended for further reduction of fire hazard that cement board or sheet metal be placed between the furnace and the combustible floor and extend 12 inches beyond the front of the door and top of the furnace.

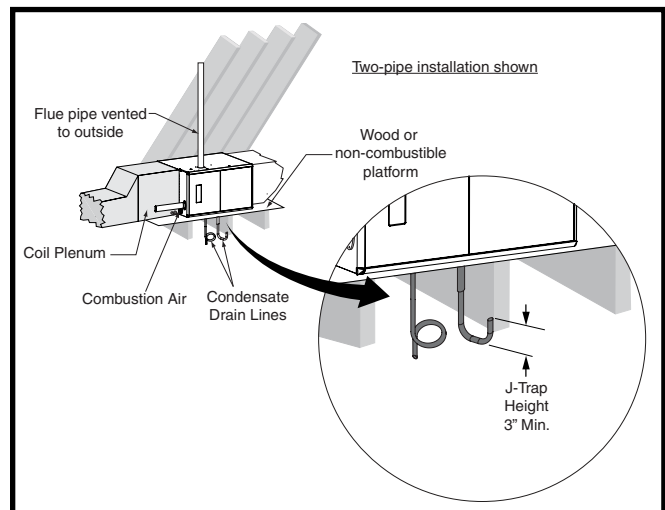

Figure 11. Horizontal installation on a Platform

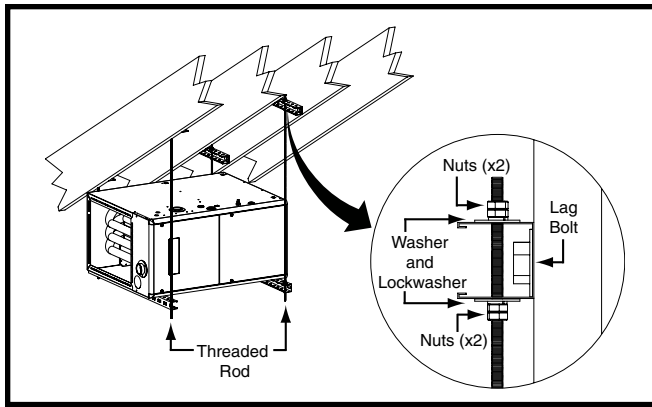

Figure 12. Horizontally Suspended in an Attic

*SD SERIES - CONVENTIONAL (1 PIPE)			
VENT DIRECTION	UPFLOW	HORIZONTAL RIGHT	HORIZONTAL LEFT
Up	Option 1	Option 7	Option 10
Right	Option 2	Option 8	N/A
Left	Option 3	N/A	Option 9

*SD SERIES - DIRECT VENT (2-PIPE)			
VENT DIRECTION	UPFLOW	HORIZONTAL RIGHT	HORIZONTAL LEFT
Up	Option 4	Option 11	Option 14
Right	Option 5	Option 12	N/A
Left	Option 6	N/A	Option 13

Table 3. Vent & Inducer Blower Options

Inducer & Venting Options

To increase installation flexibility, the inducer assembly can be rotated up to 3 different positions. Each variation has slightly different requirements with regard to condensate disposal and, in some cases, the need to seal the furnace cabinet.

IMPORTANT NOTE:

The Inducer Assembly must never be positioned to vent downwards on horizontal installs.

Before using [Table 3](#), the number of pipes (1-pipe or 2-pipe) connected to the furnace must be known. Find the proper furnace style (upflow or horizontal) and then the side that the pipes will exit from the furnace. Finally select the option that properly matches your installation type in [Figure 28](#) (page 46), [Figure 29](#) (page 47), or [Figure 30](#) (page 48).

NOTE: It is important that Direct Vent (2-pipe) systems maintain an airtight flow path from the air inlet to the flue gas outlet. The furnace ships from the factory with two holes in the cabinet for the air inlet and flue gas outlet. In certain configurations, it is necessary to remove and relocate a plastic plug in the furnace cabinet. If changing the position of the air inlet and flue gas outlet, it is required that the previous hole be closed off with the plastic plug to maintain air tightness in the furnace. The hole locations are shown in [Figure 24](#) (page 34).

Inducer Assembly Rotation

⚠ WARNING:

Inducer rotation must be completed before the furnace is connected to gas and electric. If both utilities have been connected, follow the shutdown procedures printed on the furnace label and disconnect the electrical supply.

⚠ CAUTION:

It is good practice to label all wires prior to disconnection. Wiring errors can cause improper and dangerous operation.

1. Disconnect the electrical harness from the inducer assembly.
2. Remove the inducer assembly ground wire from the blower deck.
3. Remove 3 screws securing the inducer assembly to the header box.
4. Rotate the inducer assembly to its new position.
5. Secure the inducer assembly to the header box by reinstalling the three screws. If the inducer assembly is rotated to the left or right side of the furnace, use the extra screw provided in the parts package.
6. Remove the cabinet plug from side of furnace and reinstall in hole on opposite side of cabinet.
7. Install in-line drain assembly and tubing.
8. Install all condensate drain lines. See [Figure 28](#) (page 46), [Figure 29](#) (page 47), or [Figure 30](#) (page 48).
9. Reconnect the electrical harness to the inducer assembly.
10. Verify operation as detailed on the furnace label.

Pressure Switch Tubing

All upflow / horizontal furnaces have two switches, one connected to the static tap on the inducer assembly and the other to the collector box. [Figure 31](#) (page 49) & [Figure 32](#) (page 50) display the proper routing of pressure switch tubing.

Alternate Pressure Switch Location

In some inducer orientations, the inducer pressure switch may interfere with gas pipe installation. Determine the side of the cabinet the gas pipe will enter and see if the inducer pressure switch needs to be moved. If the pressure switch interferes with the gas pipe, use these instructions for relocating it to an alternate location:

1. Shut off any electrical power to the furnace.
2. Label and disconnect the tubing and wires from the pressure switch. See [Figure 31](#) (page 49) & [Figure 32](#) (page 50).
3. Remove two screws securing the pressure switch to the inducer housing.
4. Remove the pressure switch from the mounts on the inducer housing and relocate it to the other set of mounts 90° from previous location.
5. Secure the pressure switch with two screws.
6. Reconnect the tubes and wires to the pressure switch.

Accessories

The components below are included in the extra parts bag that is supplied with the purchase of your furnace. Depending on your particular installation, some of these components are optional and may not be used. Please refer to the descriptions and accompanying figures when installing these items. **NOTE:** Some parts may not be supplied with each furnace. Refer to the literature in the extra parts bag for the parts included with the particular furnace.

Finish Flange

The finish flange must be installed to vent the combustion air pipe through the top of the furnace. **NOTE:** For proper installation it is important that the pipe and screw holes in the finish flanges, gasket, and cabinet are aligned. See [Figure 13](#).

1. Position flange gasket over hole in the furnace cabinet.
2. Position finish flange on top of the flange gasket.
NOTE: Make sure the flange is properly oriented so that the FRONT lettering is located near the front of the furnace as shown in [Figure 13](#).
3. Secure flange and gasket to cabinet with three field supplied sheet metal screws.
4. Attach a 2" PVC coupler (field supplied) to the finish flange along with a 6" minimum length of 2" PVC pipe. See [Figure 13](#).

Rubber Grommets

The 2 1/4" rubber grommet is used to seal the opening between the furnace cabinet and the 2" PVC vent pipe. The rubber grommet should be installed in the 3" hole prior to running the vent pipe out of cabinet. No sealants are required. See [Figure 14](#).

The 7/8" rubber grommet is used to seal the opening between the furnace cabinet and the gas pipe. The rubber grommet should be installed in the 1 5/8" hole prior to running the gas pipe into the cabinet. No sealants are required.

The 3/4" rubber grommet is used if venting out the left side of the cabinet and the drain tube is routed through the blower deck. Remove the plastic plug from the hole and install the grommet before routing the drain tube.

A strain relief bushing is provided for routing the pressure transducer wiring assembly.

NOTE: For proper furnace operation, make sure there are no open grommet holes from the top to the bottom section of the cabinet or open grommet holes in the cabinet.

PVC Components

IMPORTANT NOTES:

- Before permanently installing these components, it is recommended you dry-fit them first to ensure proper fit and alignment with other vent pipes.
- The 2" PVC components shown in [Figure 15](#) are not provided in the extra parts bag. However the PVC Trap (P/N 664659) can be purchased thru your local distributor.

The 2" PVC tee, reducer, PVC Trap and 1/2" X 1/2" hose barb are used when the inducer is rotated to vent out thru the left or right side of the furnace cabinet. See [Figure 15](#) ([page 16](#)).

The 1/2" X 3/4" hose barb can be used to route the condensate drain to the outside of the cabinet. It must be installed from inside the cabinet with the threaded end inserted thru the 1

1/16" hole. The condensate drain should be connected to the barbed end. Attach 1" PVC drain line to the threaded end. See [Figure 24](#) ([page 34](#)) for hole location.

Typical Orientation

1. Install the PVC Tee vertically on the 2" vent pipe that is extending out the side of the cabinet. Permanently bond them together using appropriate primer and cement. Refer to the typical orientation shown in [Figure 15](#).
2. Install the reducer or PVC trap (if supplied) on the bottom end of the PVC Tee. Permanently bond them together using appropriate primer and cement.
3. Install the 1/2" x 1/2" hose barb on the 2" PVC reducer.
NOTE: Do not over tighten! Use an adequate amount of Teflon tape on the threads. Do not use liquid sealants.
4. Verify all connections and joints for tight fit and proper alignment with other vent pipes.

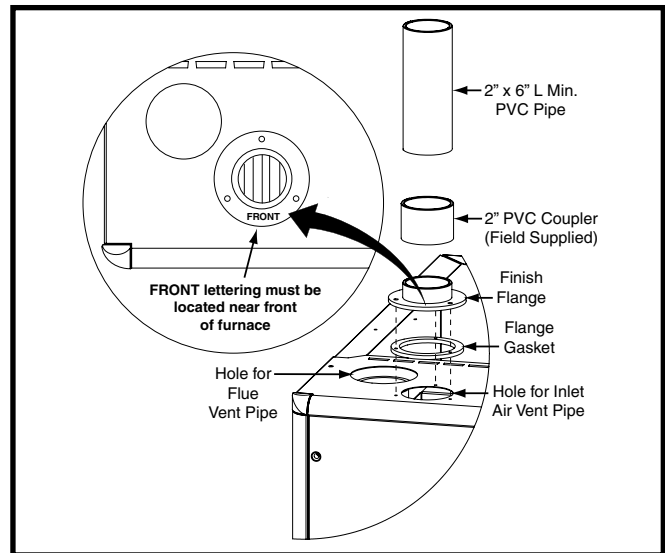

Figure 13. Finish Flange

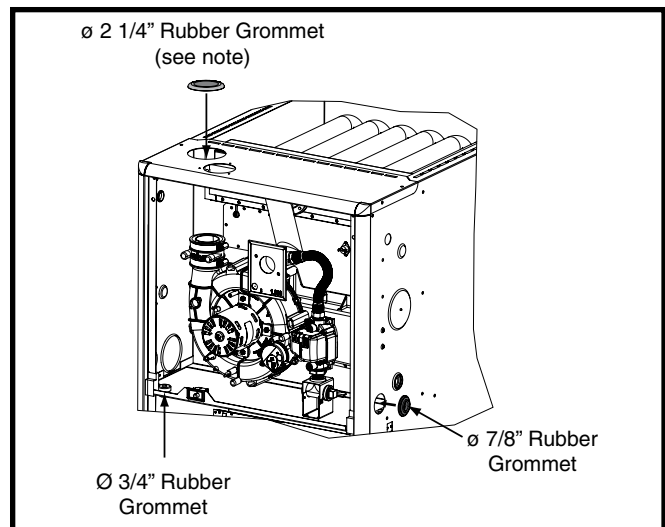

Figure 14. Rubber Grommets

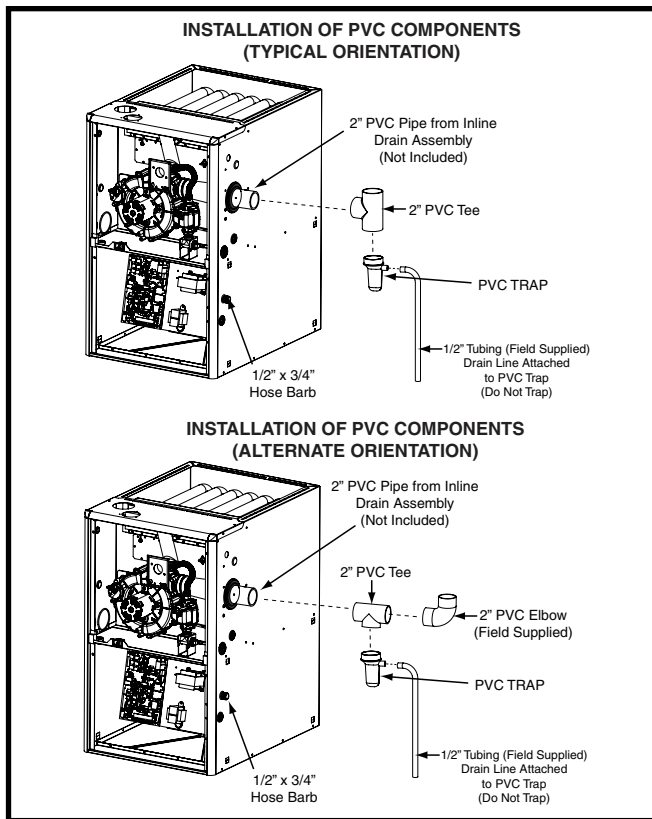

Figure 15. PVC Components

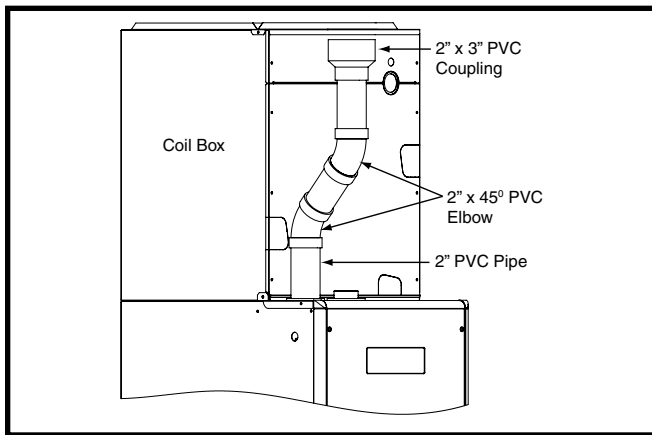

Figure 16. Optional PVC Pipe Installation

Alternate Orientation

1. Install the 2" PVC Tee horizontally on the 2" vent pipe that is extending out the side of the cabinet. Permanently bond them together using appropriate primer and cement. Refer to the alternate orientation shown in [Figure 15](#).
2. Install the 2" PVC Elbow on the end of the 2" PVC Tee. Permanently bond them together using appropriate primer and cement.
3. Install the reducer or PVC trap (if supplied) on the bottom end of the PVC Tee. Permanently bond them together using appropriate primer and cement.
4. Install the 1/2" x 1/2" hose barb on the 2" PVC reducer.
NOTE: Do not over tighten! Use an adequate amount of Teflon tape on the threads. Do not use liquid sealants.
5. Verify all connections and joints for tight fit and proper alignment with other vent pipes.

Optional PVC Pipe Installation

When running the 2" PVC pipe out through the top of the furnace, there may be possible clearance issues when transitioning the PVC pipe from 2" to 3":

- If the size of the PVC flue needs to be increased from 2" to 3", two, 2" x 45° PVC elbows may be used to achieve the clearances needed between the coil box and the 2" x 3" coupling. See [Figure 16](#).
- Install the 2" x 3" coupling in the vertical run only. If the coupling is installed horizontally, it will allow water to build up inside the furnace and cause a lock out condition.
- To avoid the clearance issue, it is recommended that the furnace be vented through the left side or the right side of the cabinet.

Condensate Drain Lines

If the furnace is installed in an area where temperatures fall below freezing, special precautions must be made for insulating condensate drain lines that drain to the outdoors. If condensate freezes in the lines, this will cause improper operation or damage to the furnace. It is recommended that all drain lines on the outside of the residence be wrapped with an industry approved insulation or material allowed by local code.

- The method for disposing condensate varies according to local codes. Consult your local code or authority having jurisdiction.
- The condensate drain line must be trapped using a kit (P/N- 922485) or field supplied parts. After the drain trap, condensate can continue to the drain by connecting to a recommended 3/4" ID minimum drain line, but no smaller than the original tubing ID supplied by the manufacturer. The drain line should slope downward away from the furnace to ensure proper drainage.
- The placement of the condensate drain lines will depend on the configuration selected in [Table 3 \(page 14\)](#). The drain lines can be routed out the left or right side of the furnace, but must maintain a downward slope to ensure proper condensate drainage. The J-trap may need to be rotated to the side that matches your setup. See [Figure 28 \(page 46\)](#), [Figure 29 \(page 47\)](#), or [Figure 30 \(page 48\)](#). To rotate the J-trap, loosen the clamp on the drain tube, rotate the J-trap to either side, and retighten the clamp.
- It is permissible to locate the trap away from the furnace. The condensate drain system (J-trap and drain tube) should be no more than 30 equivalent feet while maintaining 1/4" per foot slope, and insulated if located in an unconditioned space.

THREE GENERAL PRINCIPLES APPLY:

- Each condensate drain must be trapped separately using a J-Trap or field supplied loop. After individually trapping the condensate lines, it is acceptable to combine the drains.
- There must always be a drain attached to the collector at the outlet of the secondary heat exchanger.
- There must always be a drain at the lowest point of the venting system. **NOTE:** If using a condensate pump, the furnace drain line must be installed above the pumps water line.

EXCEPTIONS & CLARIFICATIONS TO THE GENERAL RULES:

- If the vent exits the furnace horizontally, the vent may be turned vertically with a tee. **The drip leg formed by the tee must include a drain.** (Option 2, Option 3, Option 5, Option 6, Option 8, Option 9, Option 12, Option 13).
- In certain cases, it is permitted to drain the inducer back into the top drain of the collector. **This drain must not sag in the middle.** (Option 2, Option 5, Option 7, Option 11).

Bottom Panel Removal

The steps listed below describe how to remove the bottom panel from the furnace. See [Figure 17](#).

1. Remove the door from the blower compartment .
2. Remove all screws securing the bottom panel to the front brace.
3. Remove two screws securing the furnace cabinet to the blower deck.
4. Remove all screws securing the furnace cabinet to the bottom panel.
5. Remove the screw securing the bottom corner of the furnace cabinet to the front brace.
6. Carefully spread the bottom corner of the furnace cabinet outwards while sliding the bottom panel out through the front of the furnace.
7. Reassemble the furnace in reverse order.

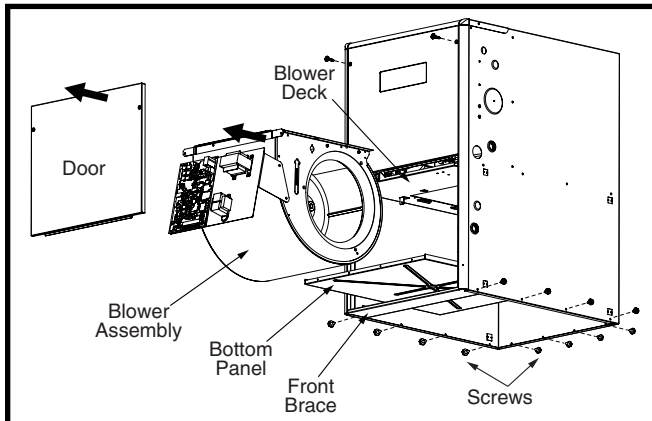

Figure 17. Bottom Panel Removal

GAS SUPPLY & PIPING

⚠ WARNING:

FIRE OR EXPLOSION HAZARD

- Failure to follow safety warnings exactly could result in serious injury, death or property damage.
- Installation and service must be performed by a qualified installer, service agency or the gas supplier.
- Do not store or use gasoline or other flammable vapors and liquids in the vicinity of this or any other appliance.

WHAT TO DO IF YOU SMELL GAS

- Do not try to light any appliance.
- Do not touch any electrical switch; do not use any phone in your building.
- Leave the building immediately.
- Immediately call your gas supplier from a neighbor's phone. Follow the gas supplier's instructions.
- If you cannot reach your gas supplier, call the fire department.

- All gas piping must be installed in compliance with local codes and utility regulations. In the absence of local codes the gas line installation must comply with the latest edition of the National Fuel Gas Code (ANSI Z223.1).
- Some local regulations require the installation of a manual main shut-off valve and ground joint union external to the furnace as shown in [Figure 18](#) (page 18). The shut-off valve should be readily accessible for service and/or emergency use. Consult the local utility or gas supplier for additional requirements regarding placement of the manual main gas shut-off.
- Per ANSI 21.47, A 1/8-inch NPT plugged tapping, accessible for test gauge connection, must be installed immediately upstream of the gas supply connection to the furnace external to the cabinet. If local codes allow the use of a flexible gas appliance connector, always use a new listed connector. Do not use a connector that has previously serviced another gas appliance.
- Gas piping must never run in or through air ducts, chimneys, gas vents, or elevator shafts.
- Compounds used on threaded joints of gas piping must be resistant to the actions of LP propane gas.
- The main gas valve and main power disconnect to the furnace must be properly labeled by the installer in case emergency shutdown is required.
- Flexible gas connectors are not recommended for this type of furnace but may be used if allowed by local jurisdiction. Only new flexible connectors may be used. Do not use a connector which has previously serviced another gas appliance.
- A drip leg should be installed in the vertical pipe run to the unit. See [Figure 18](#).

⚠ WARNING:

THE FURNACE IS EQUIPPED TO RUN ON NATURAL GAS ONLY. AN LP/PROPANE CONVERSION KIT IS NOT AVAILABLE. USE OF LP/PROPANE WITH THIS FURNACE CAN CAUSE FIRE, EXPLOSION, PROPERTY DAMAGE, CARBON MONOXIDE POISONING, PERSONAL INJURY, OR DEATH.

High Altitude

This furnace is equipped and rated to operate at altitudes up to a maximum of 5,400 Ft.. There are no conversion kits required for operation of this furnace up to 5,400 Ft.. Adjust the manifold pressure to that listed in [Table 4](#).

NOTE: The main burner orifice is located inside the brass orifice fitting attached to the combustion air inlet venturi.

[Table 15 \(page 43\)](#) lists gas flow capacities for standard pipe sizes as a function of length in typical applications based on nominal pressure drop in the line.

The furnace may be installed with either left or right side gas entry. When connecting the gas supply, provide clearance between the gas supply line and the entry hole in the furnace casing to avoid unwanted noise and/or damage to the furnace. Typical gas hookups are shown in [Figure 18](#).

FURNACE INPUT	MAIN BURNER ORIFICE SIZE	MAIN AIR ORIFICE DIAMETER	MANIFOLD PRESSURE
50,000	#30	1.050"	3.5
70,000	#26	1.125"	3.5
100,000	#16	1.380"	3.5

Table 4. Orifice Size & Manifold Pressure

Leak Check

⚠ WARNING:

FIRE OR EXPLOSION HAZARD
Failure to follow safety warnings exactly could result in serious injury, death or property damage.

Never test for gas leaks with an open flame. Use a commercially available soap solution made specifically for the detection of leaks to check all connections. A fire or explosion may result causing property damage, personal injury or loss of life.

After the gas piping to the furnace is complete, all connections must be tested for gas leaks. This includes pipe connections at the main gas valve, emergency shutoff valve and flexible gas connectors (if applicable). The soap and water solution can be applied on each joint or union using a small paintbrush. If any bubbling is observed, the connection is not sealed adequately and must be retightened. Repeat the tightening and soap check process until bubbling ceases.

IMPORTANT NOTE:

When pressure testing gas supply lines at pressures greater than 1/2 psig (14 inch W.C.), the gas supply piping system must be disconnected from the furnace to prevent damage to the gas control valve. If the test pressure is less than or equal to 1/2 psig (14 inch W.C.), close the manual shut-off valve.

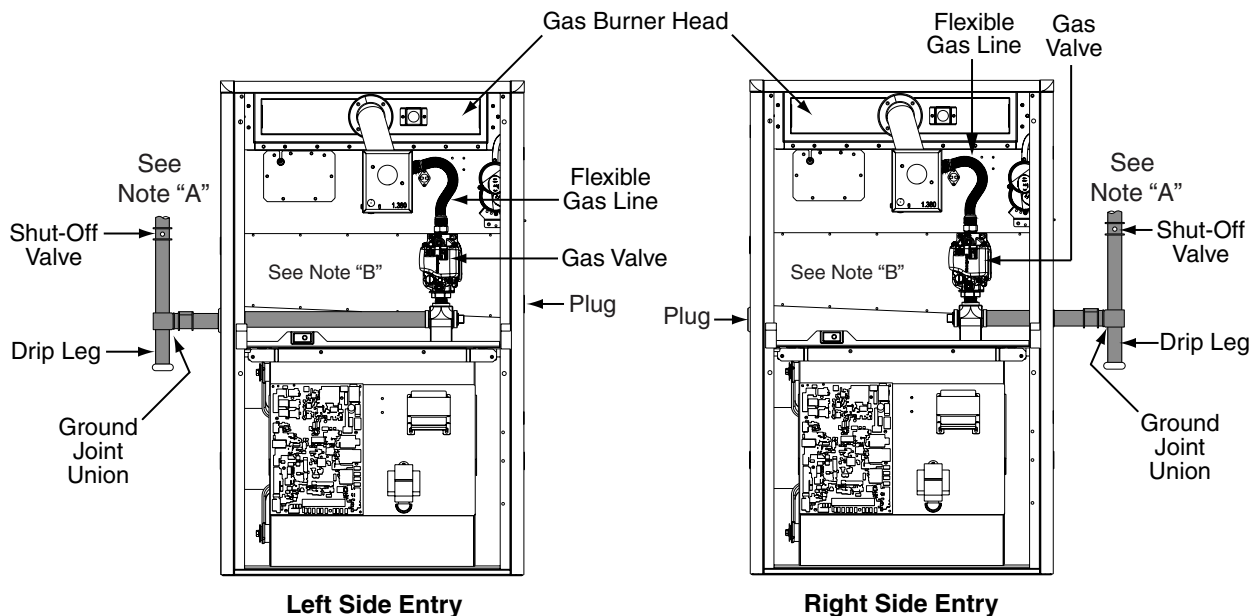

NOTE A: Consult local codes for Shut-Off Valve location requirements
NOTE B: Inducer assembly omitted for clarity of pipe installation

Figure 18. Typical Gas Connections for Upflow Models

Main Burner Gas Orifice

1. To remove the main burner gas orifice shut off the main power and gas supply to the furnace.
2. Remove the top door and inlet air orifice. The orifice is located inside the assembly and can be taken out for verification and cleaning. Refer to the [Table 4 \(page 18\)](#) for size.
3. Replace the main burner air orifice in reverse order they were removed.

Air Inlet Orifice

The combustion air inlet is a specified size and cannot be left off or changed to an alternate size. The inlet air orifices are unique between models. Interchanging, modifying or removing the air orifice plates will result in unsafe operation and erratic behavior. Refer to [Table 4 \(page 18\)](#) for main air orifice size. Only use factory size main air orifices. Refer to the RPL for replacement parts.

ELECTRICAL WIRING

WARNING:

ELECTRICAL SHOCK, FIRE OR EXPLOSION HAZARD

Failure to follow safety warnings exactly could result in serious injury, death or property damage.

Improper servicing could result in dangerous operation, serious injury, death or property damage.

- **Before servicing, disconnect all electrical power to furnace.**
- **When servicing controls, label all wires prior to disconnecting. Reconnect wires correctly.**
- **Verify proper operation after servicing.**

- Electrical connections must be in compliance with all applicable local codes with the current revision of the National Electric Code (ANSI/NFPA 70).

IMPORTANT NOTE:

If replacing any of the original wires supplied with the furnace, the replacement wire must be copper wiring and have a temperature rating of at least 105° F (40° C). For electrical specifications, refer to the furnace nameplate or [Table 5 \(page 20\)](#).

Line Voltage Wiring

It is required that the line voltage (120 VAC) to the furnace be supplied from a dedicated branch circuit containing the correct fuse or circuit breaker for the furnace as listed in [Table 5 \(page 20\)](#).

The installer should become familiar with the units wiring diagram before making any electrical connections to the unit. See [Figure 25 \(page 41\)](#), [Figure 26 \(page 42\)](#), or the unit wiring label.

IMPORTANT NOTES:

An electrical disconnect must be installed readily accessible from and located within sight of the furnace. See [Figure 25 \(page 41\)](#) or [Figure 26 \(page 42\)](#) or the wiring diagram label inside of the control door. Any other wiring methods must be acceptable to authority having jurisdiction.

Proper line voltage polarity must be maintained in order for the control system to operate correctly. Verify the incoming neutral line is connected to the white wire and the incoming HOT line is connected to the black wire. The furnace will not operate unless the polarity and ground are properly connected as shown in [Figure 19 \(page 20\)](#).

Grounding

WARNING:

To minimize personal injury, the furnace cabinet must have an uninterrupted or unbroken electrical ground. The controls used in this furnace require an earth ground to operate properly. Acceptable methods include electrical wire or conduit approved for ground service. Do not use gas piping as an electrical ground!

Thermostat / Low Voltage Connections

- The furnace is designed to be controlled by a 24 VAC thermostat. The thermostat's wiring must comply with the current provisions of the NEC (ANSI/NFPA 70) and with applicable local codes having jurisdiction.
- The thermostat must be installed according to the instructions supplied by the thermostat manufacturer. Low voltage connections (24 VAC) from the thermostat are wired to the terminal strip on the integrated control in the furnace. [Figure 20 \(page 21\)](#) contains the proper connections for heating only (two-wire) and heating/cooling (four-wire) applications. Recommended minimum wire gauge for thermostat wiring is shown in [Table 5 \(page 20\)](#).
- The thermostat should be mounted about 5 feet above the floor on an inside wall. DO NOT install the thermostat on an outside wall or any other location where its operation may be adversely affected by radiant heat from fireplaces, sunlight, or lighting fixtures, and convective heat from warm air registers or electrical appliances. Refer to the thermostat manufacturer's instruction sheet for detailed mounting information.

Twinning

Single stage furnaces are not supplied with a built-in twinning capability.

FURNACE MODEL NUMBER	FURNACE INPUT (BTUH)	CABINET WIDTH (IN.)	NOMINAL ELECTRICAL SUPPLY	MAXIMUM OPERATING VOLTAGE	MINIMUM OPERATING VOLTAGE	MAXIMUM FURNACE AMPERES	MAXIMUM FUSE OR CIRCUIT BREAKER AMPS*
*SD-050U-T23A	50,000	14 ¼	120-60-1	132	108	9.8	15
*SD-070U-T24B	70,000	17 1/2	120-60-1	132	108	9.8	15
*SD-100U-T35C	100,000	21	120-60-1	132	108	12.5	20

* Time-delay fuses or circuit breakers are required.

THERMOSTAT WIRE GAUGE	RECOMMENDED THERMOSTAT WIRE LENGTH	
	2 - WIRE - HEATING	4 OR 5 WIRE - COOLING
24	55 ft.	25 ft.
22	90 ft.	45 ft.
20	140 ft.	70 ft.
18	225 ft.	110 ft.

Table 5. Wire Length & Voltage Specifications

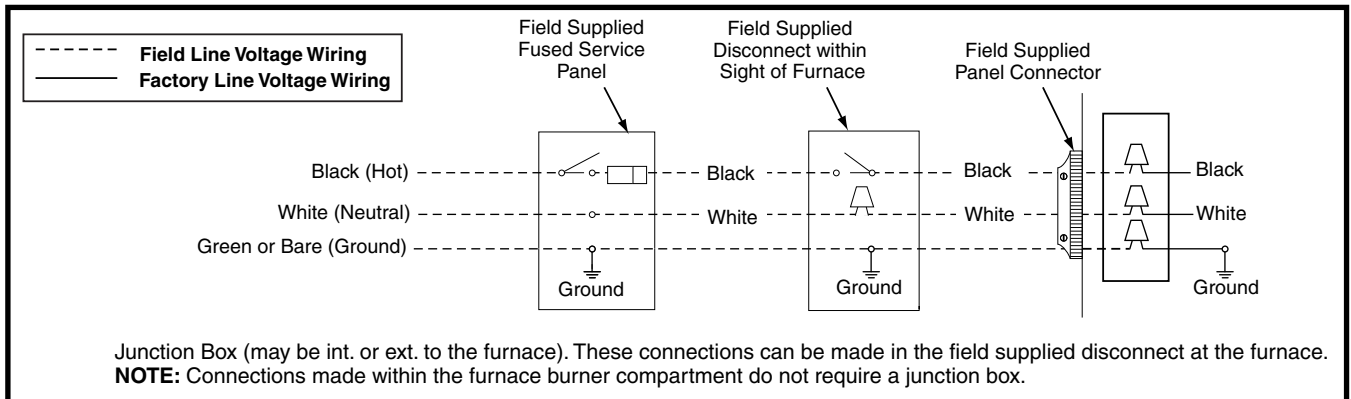
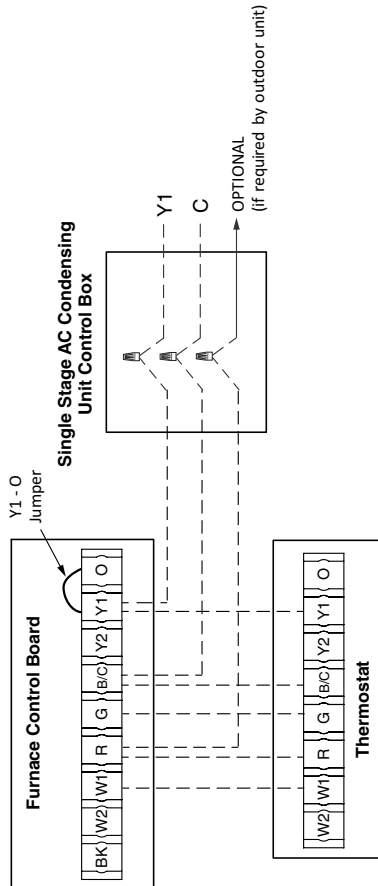

Figure 19. Line Voltage Field Wiring

THERMOSTAT CONNECTIONS FOR AC

Single Stage Heat / Cool



- NOTES:**
- 1.) Y1 must connect from the thermostat to the Furnace Control Board for proper airflow.
 - 2.) Leave factory supplied Y1 - O in place for proper LED readout.
 - a) Removing the jumper will cause the LED readout to show "HP1" instead of "CL1" with a call for cooling.
 - b) Operation of the unit is not affected

Single Stage Heat / 2 Stage Cool

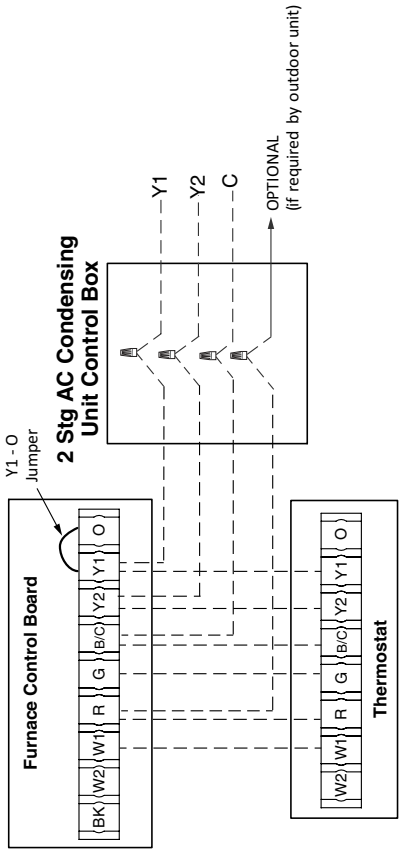

- NOTES:**
- 1.) Y1 and/or Y2 must connect from the thermostat to Y1 and Y2 of the Furnace Control Board for proper airflow
 - 2.) Leave factory supplied Y1 - O in place for proper LED readout.
 - a) Removing the jumper will cause the LED readout to show "HP1/HP2" instead of "CL1/CL2" with a call for cooling.
 - b) Operation of the unit is not affected

THERMOSTAT CONNECTIONS FOR HP

Single Stage Heat / Cool

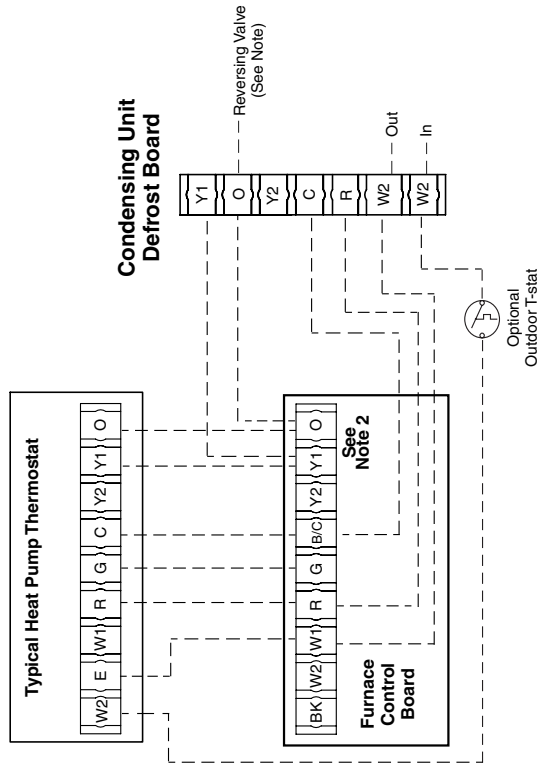

- NOTES:**
- 1.) Reversing valve energized in cooling mode of operation. Refer to the thermostat manual for detailed installation and programming instructions.
 - 2.) Remove Y1 - O jumper on Furnace Control Board for HP systems.
 - a) Y1, Y2, and O must connect from the thermostat to the Furnace Control Board for proper airflow, LED readout & defrost operation.
 - b) If Y1-O jumper is not removed, the LED readout will show "CL1/CL2" instead of "HP1/HP2" with a HP heating call.
 - c) During an OD defrost, the furnace will not operate, resulting in a cold blow complaint from HO.

Single Stage Heat / 2 Stage Cool

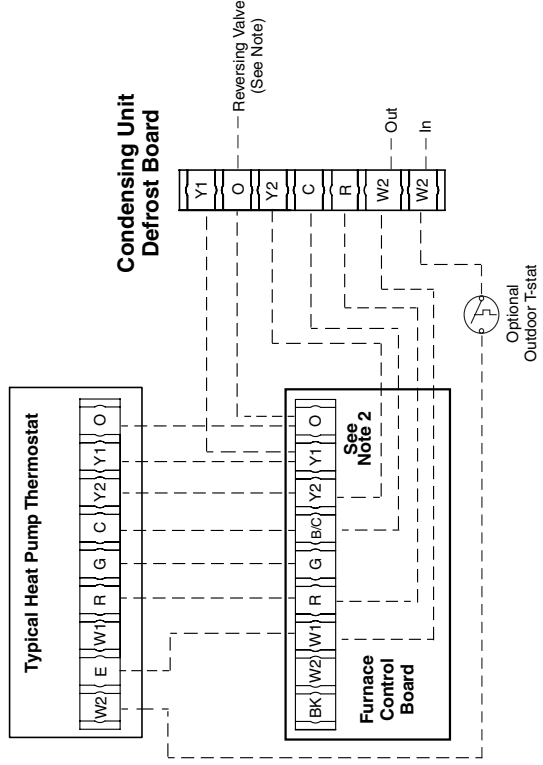

Figure 20. Low Voltage Field Wiring Applications

START-UP & ADJUSTMENTS

Pre-Start Check List

- √ Verify the polarity of the connections are correct, the line voltage power leads are securely connected and the furnace is properly grounded.
- √ Verify the thermostat wires are securely connected to the correct leads on the circuit board terminal strip for your specific air conditioning or heat pump application. See [Figure 20 \(page 21\)](#)
- √ Verify the air switches are wired correctly according to the wiring diagram. See [Figure 25 \(page 41\)](#) and [Figure 26 \(page 42\)](#).
- √ Verify the gas line service pressure does not exceed 10.0 inches of W.C., and is not less than 4.5 inches W.C. for natural gas.
- √ DO NOT install a jumper wire across a switch to defeat its function. If a switch reopens on startup, identify and correct the fault condition.
- √ Verify the blower door is in place, which closes the door switch. This ensures line voltage gets to the blower motor.
- √ Verify the gas line has been purged and all connections are leak free.

Start-up Procedures

Do not perform these steps until all of the checks in the previous steps have been completed:

1. Set the thermostat to the lowest setting.
2. Turn off all electrical power to the furnace.
3. Follow the Operating Instructions on the label attached to the furnace.
4. Set the thermostat above room temperature and verify the Operating Sequence ([page 26](#)).
5. After 5 minutes of operation, set the thermostat below room temperature and verify steps 9 - 10 of the Operating Sequence.

Verifying & Adjusting Input Rate

The input rate must be verified for each installation to prevent over-firing of the furnace. **NOTE:** The input rate must not exceed the rate shown on the furnace rating plate. To determine the exact input rate, perform the following procedures:

1. Shut off all other gas fired appliances.
2. Start the furnace and run it for at least 3 minutes.
3. Measure the time (in seconds) required for the gas meter to complete one revolution.
4. Convert the time per revolution to cubic feet of gas per hour using [Table 14 \(page 43\)](#).
5. Multiply the gas flow rate in cubic ft per hr by the heating value of the gas in Btu per cubic ft to obtain the input rate in Btuh. See example.

EXAMPLE:

- Time for 1 revolution of a gas meter with a 1 cubic ft dial = 40 seconds.
- From [Table 14](#) read 90 cubic ft gas per hr.
- Local heating value of the gas (obtained from gas supplier) = 1,040 Btu per cubic ft.
- Input rate = 1,040 x 90 = 93,600 Btuh.

6. The manifold pressure must be set to the appropriate value for each installation by a qualified installer, service agency or the gas supplier.

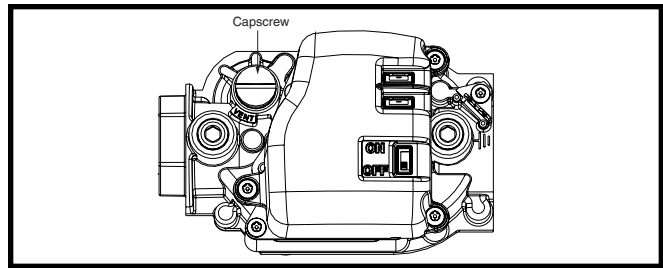

Figure 21. Regulator Capscrew

⚠ WARNING:

Do not attempt to drill the gas orifice. Use only the factory supplied orifice. Improperly drilled orifices may cause fire, explosion, carbon monoxide poisoning, personal injury or death.

- a.) Obtain the manifold pressure setting required for this installation by referring to [Table 4 \(page 18\)](#).
- b.) Remove the regulator capscrew ([Figure 21](#)) from the INLET side of the regulator.
- c.) Slowly turn the adjustment screw inside the regulator to obtain the appropriate manifold pressure.

NOTE: Turning the screw clockwise increases the pressure and turning the screw counter-clockwise decreases the pressure. To prevent backing the screw all the way out from the valve, turn the screw slowly.

- d.) Replace and tighten the regulator capscrew over the adjustment screw.

Verifying & Adjusting Temperature Rise

After installation of the furnace, confirm the temperature rise of the furnace is within the limits specified on the rating plate. Any temperature rise outside the specified limits could result in premature failure of the heat exchanger.

1. Place thermometers in the return and supply air stream as close to the furnace as possible. The thermometer on the supply air side must be shielded from direct radiation from the heat exchanger to avoid false readings.
2. Adjust all registers and duct dampers to the desired position and run the furnace for 10 to 15 minutes before taking any temperature readings. The temperature rise is the difference between the supply and return air temperatures.

For typical duct systems, the temperature rise will fall within the limits specified on the rating plate with the blower speed at the factory recommended setting. If the measured temperature rise is outside the specified limits, it may be necessary to change the speed of the blower.

NOTE: Lowering the blower speed will increase the temperature rise and a higher blower speed will decrease the temperature rise.

The furnace is equipped with a multi-speed motor. Heating and cooling speed selection is made by selections on the menu and option buttons on the control board. The LED shows which options are selected.

Verifying Burner Operation

CAUTION:

The door over the burners may only be open for inspection purposes only. The door must be installed during unattended operation.

1. Remove the burner compartment door and note the location of the sightglass on burner head.
2. Set the thermostat above room temperature and observe the ignition sequence. **NOTE:** The burner flame should be present by seeing a glow through the sightglass.
3. After validating the flame, change the thermostat setting to below room temperature.
4. Verify the burner flame is completely extinguished.
5. Replace the burner compartment door.

Verifying Operation of the Supply Air Limit Switch

NOTE: A properly functioning limit switch should turn off the gas valve when the return is blocked (time depends on how well the return air is blocked). The circulating air and combustion blowers should continue to run when the limit switch opens.

1. Verify the blower door is securely mounted in place and that there is power to the furnace.
2. Block the return airflow to the furnace by installing a close-off plate in place of or upstream of the filter(s).
3. Set the thermostat above room temperature and observe the Operating Sequence.
4. Remove the close-off immediately after the limit switch opens. If the furnace continues to operate with no return air, set the thermostat below room temperature, shut off power to the furnace, and replace the limit switch.

CONTROL BOARD FUNCTIONS

Control Interface

System Reset:

- Remove power from the control for at least 10 seconds.

Auto Restart:

- After the auto restart timer expires, the control will get out of the lockout state and automatically reset by performing the power up initialization and monitoring thermostat requests.

Interface Option Menu

The interface consists of an LED display where two switches are provided to navigate through the menu. See [Table 6 \(page 24\)](#).

Main Switch and Option

Main switch is used to browse the main menu and the Option switch to browse the option menu.

- When the main switch is pressed, the display will show the next available menu in the sequence.
- While in the main menu, press the option switch to scroll through the available options.
- While in the option menu, the selected option or default option if not selected will be displayed first and the other available option are displayed in order.
- The 1st value is the default when multiple options are available.

- While navigating in the menu option, the current displayed option is selected by pressing the main switch. The display will then go back to the main menu its currently in.
- When navigating from the last available option, the control will display the corresponding main menu, then display the selected option or default option, then the next option for each key pressed.
- While in any menu other than the Status Menu, after 30 seconds of inactivity the display will go to the Status Menu automatically and the currently displayed option is NOT considered to be selected.
- Changes made while in operation or in alarm condition, the selected option will become effective on the next valid call of operation.
- At power up, the control will display “8.”,”8.”, and “8”. until control is ready to respond to demands, then go to the Status Menu.

Reset to Factory Default

- The reset to factory default function is allowed while the control is in any operation or idle state
- The reset to factory default parameters will only take effect on the next call of operation.
- Any active alarms will not clear after a factory reset
- Factory reset is allowed at the Status Menu except when fault erase is requested from the last 6 faults and the fault erase is in progress.

If both the Menu and Option switch are pushed and held for more than 5 seconds and less than 30 seconds, the control will reset to the factory default values, clear the alarm(s) in Last 6 Fault menu and Flash “F” and “d” three times to indicate a successful factory reset. The control will then go back to the Status Menu. If any alarm is still active, the active alarm will remain in the Last 6 Fault Menu.

When the blower motor is running, “tP” is displayed following with the Tap number. For instance, If the blower motor has been set for Tap 4, “tP4” will be displayed.

If an alarm is detected, the error coded is displayed starting with “E” followed with the two digit error code. For instance “E3.4” would correspond to Pressure switch #2 opening during the heat cycle.

Active Alarm Menu

- To Navigate from the status menu to the active alarm menu, press the MENU button once. Then push OPTION to navigate through the alarm(s).
- A maximum number of 4 alarms are included in this menu.
- When the Alarm(s) is active, the alarm(s) are saved into Last 6 Faults Menu
- The alarm(s) are stored in the sequence they occur.
- If the total number alarms exceed the max alarms that can be stored, the oldest alarm is pushed out from the active Error menu at first.

Last 6 Faults Menu

- To Navigate from the status menu to the active alarm menu, press the Menu button once.
- To review the options, press the option button to browse the last 6 faults stored.
- A maximum number of 6 alarms are included in the menu
- The alarm(s) are stored in the sequence they occur.
- If the total number alarms exceed the max alarms that can be stored, the oldest alarm is pushed out from the Last 6 Faults Menu

	MAIN MENU			OPTION MENU		
	Segt #1	Segt #2	Segt #3	Segt #1	Segt #2	Segt #3
Status Menu	See Status Menu Section			N/A		
Active Alarm Menu	E	r	r	E	See Alarm Priority section for alarm code definition	
Last 6 Faults	L	B	F	E		
Code Release Number		C	r	CR Number		

	MAIN MENU			OPTION MENU		
	Segt #1	Segt #2	Segt #3	Segt #1	Segt #2	Segt #3
Cooling Off Delay	C	0	d	45 Seconds		
Outdoor Unit	0	d	U	1	-	1
				2	-	1
Heat Off Delay	H	0	d	60, Seconds		
				100, Seconds (default)		
				140, Seconds		
				180, Seconds		
Blower Tap Programming for Continuous Fan Mode	C	0	F	C F .xx fan speed number 1 (default), 2, 3, 4, 5, 6, 7, 8, 9		
Blower Tap Programming for Compressor Mode	C	0	P	C 1 .xx 1st stage Speed number 1, 2, 3, 4, 5, 6 (default), 7, 8, 9 when ODU=1-1		
				C 1 .xx 1st Stage Speed number 1, 2, 3, 4, 5, 6 (default), 7, 8 when ODU=2-1		
				C 2 .xx 2nd Stage Speed is always higher than the single stage Speed		
Blower Tap Programming for Gas Heat Mode	H	t	P	H 1 .xx 1st stage Speed number 1, 2, 3, 4, 5, (default), 6, 7, 8, 9		
Run Test Mode	r	U	n	r U .xx Run Test Steps		

MODE	MAIN MENU		
	SEGMENT #1	SEGMENT #2	SEGMENT #3
Idle	1	d	L
Continuous Fan	C	0	F
Compressor Cooling	C	L	1 or 2
Gas Heat	H	t	1
Defrost	d	F	t

Table 6. Human Interface Segment Menus

- The Last 6 Faults Menu is updated when the option button is pressed to display the next fault.
- While in the Last 6 Faults Menu, the option button can be held for more than 5 seconds and less than 30 seconds to clear all alarm(s) in the Last 6 Faults Menu.
- The display will flash “_” “_” “_”, and “_” three times to indicate the alarm(s) are removed and the display will go back to the Last 6 Faults menu.

Configuring The Blower

The fixed speed high efficiency blower is equipped with a microprocessor control which is designed to provide a variety of system airflows and comfort options. Before operation, the fixed speed high efficiency blower must be configured to match the unit with the system, system options, and climate conditions.

IMPORTANT NOTE:

The fixed speed high efficiency blower is designed to give the installer maximum flexibility to optimize system performance, efficiency, and comfort. Because there are so many ways to configure the blower, it is important to read and follow these instructions carefully.

Selecting Cooling for 1st or 2nd Stage and Blower Speed Selection

NOTE: Power must be applied to the board or the unit can be functioning to change the blower speed.

NOTE: The installer will have to review the blower tables and set the cooling speed to match the outdoor unit. See [Table 8 \(page 35\)](#), [Table 9 \(page 36\)](#), [Table 10 \(page 37\)](#), [Table 11 \(page 38\)](#), [Table 12 \(page 39\)](#), & [Table 13 \(page 40\)](#).

- When the furnace does not have a call for heating, cooling or fan, the 3 digit display will show “1dL” which means “idle”.
- Press the MENU button, the control will show the options on the display. Keep pressing the MENU button, the options are: Err-L6F-Cr-Cod-OdU-HOd-COF-COP-HtP-RUN.
- OdU (Outdoor Unit) is the cooling mode. While OdU is on the LED Display, press the OPTION button to go into the cooling menu.
 - “1- 1” means 1 stage and one compressor outdoor unit (when this is selected a call for Y2 second stage cooling is ignored).
 - “2- 1” means 2 stage and one compressor outdoor unit.
- To rotate from “1- 1” to “2- 1”, keep pressing the OPTION button. If you have a Single stage unit, while the LED display is showing “1- 1”, press MENU. This will set the indoor unit to be for single stage cooling.
- If you have 2 stage cooling, select “2- 1” by pressing the MENU button. This will set the indoor unit to be for 2 stage cooling.
- COP is the tap selection for cooling. When “1- 1” has been selected, the blower speed setting can then be selected. Press OPTION again and again to scroll through the selections. Blower tap setting 1-9 are available for single stage cooling. The default is set at 6.
- The cooling speed will then flash on the LED. By pressing the OPTION, the available cooling speed taps will be displayed which are 1-9. Press MENU to select the blower tap setting that is displayed. For example, if C1.7 is displayed, press MENU and it will be stored as the Cooling mode selection for the blower.

- When “2- 1” has been selected, the blower speed setting can then be selected. Press OPTION again to scroll through the selections. The default is set at 6 for 1stage cooling and 7 for stage 2 cooling.
- Press OPTION to select the blower tap setting that is displayed. For example, if C1.7 is displayed, press MENU and it will be stored as the cooling blower tap selection for the blower for 1st stage cooling.
- The control LED will then immediately prompt for 2nd stage cooling blower tap to be set. The LED will show the allowable blower tap settings by pressing OPTION again and again. After the desired blower tap setting for 2nd stage cooling is displayed, press MENU to save the selection. For example, if C2.8 is displayed, press MENU and it will be stored as the 2nd stage cooling setting.

NOTE: The second stage cooling tap setting cannot be lower than the 1st stage setting. For example, if 1st Stage cooling is 1.7, then 2nd stage cannot be 2.7 or lower. Also, Tap 9 cannot be used for 1st stage cooling because there is not a higher setting for 2nd stage cooling.

NOTE: If the unit is operating while changing the blower tap setting, the new blower tap setting will change upon the next call for the cooling sequence.

Cooling off Delay(COD)

This is an option on the board but cannot be changed. The default for the cooling off delay is 45 seconds.

Selecting the (Gas) Heating Speed

NOTE: Power must be applied to the board or the unit can be functioning to change the blower speed.

NOTE: The installer will have to review the blower tables and set the heating speed. See [Table 8 \(page 35\)](#), [Table 9 \(page 36\)](#), [Table 10 \(page 37\)](#), [Table 11 \(page 38\)](#), [Table 12 \(page 39\)](#), & [Table 13 \(page 40\)](#).

- When the furnace does not have a call for heating, cooling or fan, the 3 digit display will show “1dL” which means “idle”.
- Press the MENU button, the control will show the options on the display. Keep pressing the MENU button, the options are Err-L6F-Cr-Cod-OdU-HOd-COF-COP-HtP-rUn.
- HTP is the gas heat mode blower tap selection. While HTP is on the LED display, press the OPTION button to show the current blower tap selection. Default is Tap 5.
- When Option is pressed again and again, the control will rotate through the blower motor tap choices. Blower taps 1-9 are available in heating mode.
- The default blower tap speed is set at 5. H1.1 would be Tap 1, H1.2 is Tap 2 H1.3 is Tap 3, H1.4 is Tap 4, H1.5 is Tap 5, H1.6 is Tap 6, H1.7 is Tap 7, H1.8 is Tap 8 and H1.9 is Tap 9.
- Once the desired blower Tap is displayed on the board, push MENU to store the selection. For example, if H1.6 is displayed, press MENU and it will be stored as the Gas Heat mode selection for the blower.

NOTE: If the furnace has a call for heat while changing the blower tap setting, the new blower tap setting will change upon the next call for the heat sequence.

Review the blower tables for proper blower tap settings for gas heat. See [Table 8 \(page 35\)](#), [Table 9 \(page 36\)](#), [Table 10 \(page 37\)](#), [Table 11 \(page 38\)](#), [Table 12 \(page 39\)](#), & [Table 13 \(page 40\)](#).

Selecting Heat Off Delay (HOd)

This function is to change the time the blower will be energized once the call for heat(W1) has completed.

NOTE: Power must be applied to the board or the unit can be functioning to change the Heat Off Delay.

1. Press the MENU button, the control will show the options on the display. Keep pressing the MENU button, the options are Err-L6F-Cr-Cod-OdU-HOd-COF-COP-HtP-rUn.
2. HOd is the Heat Off Delay selection. While HOd is on the LED display, press the OPTION button to select the Heat Off Delay. The LED display will show the current Heat Off Delay. The default is 100 seconds.
3. The choices are 60,100,140 and 180 seconds. Press OPTION again and again to scroll through the choices. Once the desired setting is on the LED display, press the MENU button to save the new setting.

Determining Nominal System Capacity

In order to select the appropriate airflow for AC operation, the nominal system capacity must be known. The nominal system capacity is ALWAYS the nominal capacity of the outdoor unit. In some cases, the nominal system capacity is not the same as the nominal capacity of the indoor coil.

For maximum capacity and energy efficiency, generally a selection at or near the top of the CFM range for that nominal system capacity is best. For maximum dehumidification, select an airflow near the middle or bottom of the CFM range for that nominal system capacity.

NOTE: If coil icing is observed, the cooling airflow may be set too low. Make sure the setting selected is within the range shown. Also, verify the system is properly charged (see outdoor unit installation instructions). If icing continues to occur, raise the selected airflow.

System Operation

(Gas) Heating Mode or Heat Pump Emergency Heat

When the thermostat calls for heating, the circuit between **R** and **W** is completed. The furnace control board initiates the ignition sequence. Approximately 30 seconds after the gas flame has proven, the blower motor will slowly ramp up to the selected motor torque. The blower will continue to operate after the call for heat has been removed for 100 seconds. **NOTE:** All on- and off-delays for heating continue to be controlled by the furnace control board.

AC or Heat Pump Cooling Mode

When the thermostat calls for cooling, the circuit between **R**, **G**, and **Y** (and **O** on heat pumps) is completed. The blower slowly ramps up to the selected cooling motor torque.

Heat Pump Heating Mode

When the thermostat calls for heating, the circuit between **R**, **G**, and **Y** is completed. The blower slowly ramps up to the selected cooling mode torque.

Heat Pump Heating-Defrost Mode

When the outdoor unit requires defrosting, the OD defrost control will energize **W1** & **O** terminals while continuing to operate the compressor with OD fan off. The control board will display (dft). Indoor blower will continue to operate at compressor heating speed until blower heat on delay expires, then move to the highest requested airflow based on call for compressor heat mode. Stage 1 (**Y1**), Stage 2 (**Y1** & **Y2**), or Gas Heat **W1** input. When defrost terminates and inducer and blower off delay expire, the blower will return to heat pump heating speed.

Manual Fan

When the manual fan switch on the thermostat is on, (energizing G only) the blower will operate on a default setting of blower tap 1. Refer to [Table 8 \(page 35\)](#), [Table 9 \(page 36\)](#), [Table 10 \(page 37\)](#), [Table 11 \(page 38\)](#), [Table 12 \(page 39\)](#), & [Table 13 \(page 40\)](#) and the Continuous Fan Blower Tap Setting section below.

Selecting Continuous Fan Blower Tap Setting

NOTE: Power must be applied to the board or the unit can be functioning to change the continuous fan speed.

1. Press the MENU button, the control will show the options on the display. Keep pressing the MENU button, the options are Err-L6F-Cr-Cod-OdU-HOd-COF-COP-HtP-rUn.
2. Blower taps 1-9 can be selected for the continuous fan setting.
3. COF is the continuous fan mode blower tap setting. While COF is on the LED display, press the OPTION button to scroll through the selections for the continuous fan blower tap settings.
4. Press the OPTION button again and again to scroll through the continuous fan blower tap settings. CF.1(Default), CF.2,CF.3, CF.4, CF.5, CF.6, CF.7, CF.8, CF.9 will show on the LED. Once the desired continuous fan blower setting is displayed on the LED, press MENU to save the selection.

NOTE: Refer to for air flow data. See [Table 8 \(page 35\)](#), [Table 9 \(page 36\)](#), [Table 10 \(page 37\)](#), [Table 11 \(page 38\)](#), [Table 12 \(page 39\)](#), & [Table 13 \(page 40\)](#).

Fault Conditions

There is a green and a red LED (labeled "Status") on the furnace control board to provide system faults as described below. Refer to [Table 7 \(page 29\)](#) to determine motor control board fault conditions.

Electronic Air Cleaner (EAC)

The EAC relay is energized 5 seconds after the blower is running and de-energized after the blower stops. The EAC has dry contacts, therefore power will need to be supplied to one side of the EAC terminal.

Humidifier (HUM)

The HUM relay is energized when a flame has been detected and the blower is running. The HUM relay is de-energized when no flame is detected. The HUM has dry contacts, therefore power will need to be supplied to one side of the HUM terminal

OPERATING SEQUENCE

The operating sequences for the heating, cooling, and fan modes are described below. Refer to the field and furnace wiring diagrams: [Figure 19 \(page 20\)](#), [Figure 20 \(page 21\)](#), [Figure 25 \(page 41\)](#), and [Figure 26 \(page 42\)](#).

Heating Cycle

1. The thermostat calls for heat by energizing the W terminal with 24VAC.
2. The control checks the HLI input for a closed limit.
3. The control performs a circuitry check and verifies that all 3 pressure switches are open. If any pressure switches are closed during this check, the control will monitor and wait for 30 seconds for them to open. If the pressure switches are still closed after 30 seconds the LED will show error codes of 3.1 and 3.3. If both pressure switches are open during this check the control will cycle through the next circuitry check.

4. The control continuously monitors the gas valve circuitry to verify the gas valve relay and presence of voltage at the valve. If there is a voltage detected at the gas valve without a call for heat, error 7.1 will be displayed.
5. After a successful pressure transducer circuitry check, the system will energize the inducer motor. Control monitors the voltage from the pressure transducer but ignores low voltage before the inducer is activated. Once the inducer is activated, a voltage from the pressure transducer .2 volts or less is considered low and will show a 4.1 Error code. If the voltage is between .2 and .7 volts and pressure switch #1 fails to close at a call for heat, Error 3.2 is reported.
6. Once the inducer energizes, voltage between .2 and .7 is detected, and the-.5"WC pressure switch is detected closed, the inducer 30 pre-purge begins.
7. The inducer will ramp down to 400 RPM.
8. After the completion of the pre-purge, the control will start the 20 second igniter warm-up period.
9. After completion of the igniter warm up period, the 4 second trial for ignition period begins.
10. The gas valve is energized. Flame failure response is set at (2.5 seconds).
11. The ignitor is de-energized as soon as flame is sensed, or at the end of the ignition activation period(IAP) of 2 seconds.
12. When the flame is sensed , the blower heat on delay begins.(25s) and the inducer will start to ramp up.
13. The control will start monitoring the -.95"WC and -2.4"WC pressure switches for closure.
 - For the A050, the time delay to monitor the -.95"WC and -2.4"WC pressure switches is 20 seconds after flame sense.
 - For the B070, the time delay to monitor the -0.70"WC and 2.40"WC pressure switches for closure is 31 seconds after flame sense.
 - For the C100, the time delay to monitor the -.95"WC and -2.4"WC pressure switches is 31 seconds after flame sense.
14. When the thermostat is satisfied, the gas valve immediately de-energizes and the heat off delay of 100(Default) seconds begins.
15. The inducer output remains on for a 30 second post-purge period.
16. If the call for heat is lost while the control is in the trial for ignition period without flame being detected, the control will turn off the gas valve and ignitor. The control will enter the post purge routine of 60seconds. After completing the post purge, the control will resume normal operation.

Retry

If the first ignition attempt fails during a normal heat cycle sequence, the control will perform retry as follows:

1. The control will de-energize the gas valve.
2. The inducer will remain energized and start the inter-purge of 30 seconds.
3. During inter-purge, if the call for heat is present and pressure switch #1 opens, the control will display E3.2 and inter purge at max inducer speed.
4. If the call for heat is removed during inter-purge, the control will clear the alarm and execute the remaining inter-purge with the existing inducer speed without monitoring pressure switch #1.
5. After the inter-purge time expires, the control turns off the inducer and waits for the pressure switch to open before

continuing another ignition sequence. The normal ignition sequence is restarted.

6. The control will retry 4 times before entering an External Lockout.
7. The control will complete the inter-purge from the last ignition attempt before going into external lockout and will display every alarm code.

Auto Reset

When entering an external lockout of 60 minutes:

1. The blower motor will energize for 60 minutes then de-energize.
2. Control will perform an Auto-Restart Purge.
3. Clear the alarm.
4. Perform a system reset and return to normal operation.

If the gas heat call is removed during the lockout, the control will turn off the blower, clear the alarm, perform a system reset and be ready for the next call.

Recycle

If the flame is detected during the trial for ignition and then lost:

1. The gas valve will be de-energized.
2. The control will turn off the inducer after post-purge and wait for pressure switch #1 to open before continuing another ignition sequence.
3. The blower will remain running if its already running. Otherwise the blower will remain off.
4. Start Recycle Timer.
5. After the Recycle Timer expires, normal ignition sequence is started without performing a pre-purge. After reaching the max recycle count of 10, the control will go into and external lockout, start the Auto-Restart timer and report the recycle alarm code on the display. After the Auto-Restart Reset timer expires, the control will exit the External Lockout.
6. The blower motor will energize for 60 minutes then de-energize.
7. Control will perform an Auto-Restart Purge.
8. Clear the alarm.
9. Perform a system reset and return to normal operation.

If the gas heat call is removed during the lockout, the control will turn off the blower, clear the alarm, perform a System Reset and be ready for the next call.

Cooling Cycle

When **Y1** and **G**, or **Y1**, **Y2** and **G** signals are detected, the control will operate in compressor cooling mode. The Electronic Air Cleaner (EAC) relay will energize 5 seconds after the blower is running. The EAC will be de-energized after the blower is turned off.

1st Stage Cooling

1. When **Y1** and **G** are detected simultaneously, the control will energize the blower with 1st stage cooling airflow and display 1st stage cooling (**CL1**) on the display. The blower motor does not have an on delay.
2. If **Y1**, and **G** are removed simultaneously or only **G** is removed, the display will display "idL".

2nd Stage Cooling

1. When **Y1**, **Y2**, and **G** are detected simultaneously, the control will operate the blower in 2nd stage cooling speed and display 2nd stage cooling (**CL2**).
2. If **Y1**, **Y2** and **G** are removed simultaneously or only **G** is removed, the control will display "idL".

Fan Mode

- When the thermostat energizes the **G** terminal for continuous fan (without calling for heat or cool), the indoor fan is energized on the selected FAN speed. See [Table 8 \(page 35\)](#), [Table 9 \(page 36\)](#), [Table 10 \(page 37\)](#), [Table 11 \(page 38\)](#), [Table 12 \(page 39\)](#), & [Table 13 \(page 40\)](#) for fan speed settings.
- If a call for cooling occurs during continuous fan, the blower will switch over to the selected COOL speed.
- If the call for heat occurs during continuous fan, the blower will switch over to the selected heat speed. See [Table 8](#), [Table 10](#), & [Table 12](#) for factory heat speed settings.
- A call for fan is ignored while in lockout.
- If the blower fails to operate as specified, refer to [Figure 22 \(page 32\)](#) for motor troubleshooting.

MAINTENANCE

WARNING:

ELECTRICAL SHOCK, FIRE OR EXPLOSION HAZARD

Failure to follow safety warnings exactly could result in serious injury, death or property damage.

Improper servicing could result in dangerous operation, serious injury, death or property damage.

- **Before servicing, disconnect all electrical power to furnace.**
- **When servicing controls, label all wires prior to disconnecting. Reconnect wires correctly.**
- **Verify proper operation after servicing.**

- Proper maintenance is most important to achieve the best performance from a furnace. Follow these instructions for years of safe, trouble free operation.
- These maintenance instructions are primarily intended to assist qualified technicians experienced in the proper maintenance and operation of this appliance.
- Always reinstall the doors on the furnace after servicing. **Do not operate the furnace without all doors and covers in place.**
- Verify the thermostat is properly installed and will not be affected by drafts or heat from lamps or other appliances.
- To achieve the best performance and minimize equipment failure it is recommended that a yearly maintenance checkup be performed. At a minimum, this check should include the following items:

Air Filter(s) - Air filter(s) are not supplied with the furnace as shipped from the factory. The installer must provide a high velocity filter that is appropriately sized to the return air duct opening or external filter rack.

WARNING:

Never operate the furnace without a filter in place. Dust and lint can build up on internal components, resulting in loss of efficiency, equipment damage, and possible fire.

It is recommended that filter(s) be 1" or 2" thick and be cleaned or replaced monthly.

Filters designed to remove smaller particles such as pollen, may require additional maintenance. Filters for side return and bottom return applications are available from most local distributors.

Blower Compartment - Dirt and lint can create excessive loads on the motor resulting in higher than normal operating temperatures and shortened service life. It is recommended that the blower compartment be cleaned of dirt or lint that may have accumulated in the compartment or on the blower and motor as part of the annual inspection.

Vent System - Check the inlet pipe (if applicable) and outlet pipe to ensure they are not blocked by debris. Any damaged section of vent pipe must be replaced, and any obstruction or blockage must be removed prior to operating the furnace.

Heat Exchanger & Burner Maintenance - The furnace should operate for many years without soot buildup in the flue passageways, however, the flue, and vent system should be inspected and cleaned (if required) by a qualified service technician annually to ensure continued safe operation. Pay attention to any deterioration from corrosion or other sources.

WARNING:

Holes in the vent pipe or heat exchanger can cause combustion products to enter the home. Replace the vent pipe or heat exchanger if leaks are found. Failure to prevent the circulation of combustion products into the living space can create potentially hazardous conditions including carbon monoxide poisoning that could result in personal injury or death.

Lubrication - The bearings in the blower motor and inducer blower used in these furnaces are pre-lubricated and sealed by the manufacturer. No further oiling of the bearings is required for the life of the motor.

TROUBLESHOOTING

If the furnace fails to operate check the following:

- Is the thermostat operating properly?
- Are the blower compartment door(s) in place?
- Is the furnace disconnect closed?
- Has the circuit breaker tripped or the control board fuse burned open?
- Is the gas turned on?
- Are any manual reset switches open?
- Is the filter dirty or plugged?
- Is the flame sensor coated? (Remove and clean with steel wool. **(Do not use emery cloth or sandpaper!)**)
- Is there blockage in the condensate drain switch? Also verify that there is no double trapping of condensate.
- Is the secondary heat exchanger free of debris and clogs?
- Is evaporator coil clean and free of debris (If applicable).
- Are all the LED's on the furnace control board constantly ON? If not, refer to [Table 7 \(page 29\)](#) or the wiring diagram, [Figure 25 \(page 41\)](#) & [Figure 26 \(page 42\)](#) to determine fault condition.

***SD FAULT CODES AND TROUBLESHOOTING GUIDE**

ALARM	ALARM EXPLANATION	LED BOARD DISPLAY	TROUBLESHOOTING	DESCRIPTION
Internal Failure Error	Frequency out of Range	E01	<ol style="list-style-type: none"> 1. Check for low input voltage. 2. Powering the furnace with generator could cause this error. Check for loose incoming power wires. 	Voltage Frequency is out of range. The control board monitors the voltage frequency and will allow 56-64 Hz for normal operation.
External Lockout	Ignition Retry Exceeded. Failure to ignite 5 times.	E2.1	<p>Look through sight glass to see if its lighting gas.</p> <ol style="list-style-type: none"> 1. Does the unit light? If yes, then the flame sensor could be dirty or damaged or the wiring between the board and the flame sensor is damaged. 2. If the unit is not lighting, check the gas valve and ignitor. Possible issues: Faulty gas valve, ignitor bad, gas valve switch off, wire(s) not connected, check the gas supply 	The control will try to establish flame the initial try plus 4 re-tries. The control will display E2.1 after 5 tries to light during the same heat call.
	Recycles exceeded. Limit or pressure switch opening 10 times during heat operation	E2.2	<p>Intermittent opening of limit or pressure switch</p> <ol style="list-style-type: none"> 1. Check for loose wiring at all switches. 2. Check all pressure and limit switches for function. 3. Check for low airflow which could trip a limit before the thermostat setting is satisfied. 	Once flame has been established, the control monitors that all pressure switches and limits are closed. If any switch opens for at least 2 seconds the control will stop the heat sequence and will initiate post purge. The control will recycle the heat sequence 10 times if a pressure switch or limit switch opens and there is still a call for heat. After the 10th recycle the control will display E2.3. If the call for heat is satisfied in the recycle sequence, the recycle count will start over.
	Internal Control Fault	E2.3	Internal relay in the control board has failed- Replace the board.	Control senses 24V output to the gas valve. If voltage is not sensed to the gas valve, the control will display E2.3.
	HLO Relay on control board failure to energize 10 times. Internal Control Fault	E2.4	Internal relay in the control board has failed- Replace the board.	Relay on the board is not supplying 24V. The control monitors 24V outputs to internal relays. If the HLO output is not energized after 10 retries, the control will display E2.4. - Replace the board
	Open Pressure Switch #2 Recycles Exceeded 5 tries	E2.6	<ol style="list-style-type: none"> 1. Check for a blocked restricted vent. 2. Check the Inducer Pressure Switch #2 and Collector Switch to be faulty or stuck open. Refer to the wiring diagram for Pressure Switch #2 wiring. 	Pressure switch #2 detected open 5 times in the same call for heat. Once flame is established, after 35 seconds the control will start to monitor the inducer pressure switch #2 and the collector switch. If either switch open during operation, the control will initiate the post purge sequence and then restart the ignition sequence. If the inducer pressure switch #2 or the collector switch open in the same call for 5 heat times, the control will display E2.6.
Pressure Switch 1 Error -.5"WC	Pressure Switch #1 closed at initial call for heat	E3.1	<ol style="list-style-type: none"> 1. Check inducer pressure switch #1 to be closed. 	The control checks at the beginning of the heat cycle to see if pressure switch #1 is open. If open, the heat cycle proceeds. If pressure switch #1 is closed, Error 3.1 is reported
	Pressure Switch #1 opens during heat cycle	E3.2	<ol style="list-style-type: none"> 1. Check for loose wires at Pressure Switch #1. 2. Faulty switch 3. Check for a blocked inlet on top of the furnace. 4. Check the inlet air orifice for debris. 5. Check the hose for damage. 	The control monitors pressure switch #1 (PS1 on the board) during the heat cycle, if pressure switch #1 opens for more than 8 seconds, the heat cycle ends and E3.2 is reported

Table 7. *SD Fault Codes

***SD FAULT CODES AND TROUBLESHOOTING GUIDE**

ALARM	ALARM EXPLANATION	LED BOARD DISPLAY	TROUBLESHOOTING	DESCRIPTION
Igniter Failure Error	Igniter open or Igniter relay fails	E6.3	Damaged open igniter or internal control relay. 1. Check wiring, verify the igniter is connected. 2. Watch through sight glass to see if it glows during ignition. 3. Measure the igniter resistance, if less than 100 ohm then its probably good. If greater than 100 ohm, replace the igniter. 4. If the igniter is good then igniter relay is stuck open or closed.- Replace the board.	Controls senses if the igniter is open.Measure igniter resistance if less than 100 ohms then probably good. If igniter is good then board needs to be replaced.
External Gas Valve Error (Internal Lockout)	Power at Gas Valve detected without a call for heat	E7.1	1. Check voltage on gas valve when there is not call for heat. If voltage is present, check wiring. The gas valve should not have voltage present without a call for heat. 2. If the E7.1 is still present after verifying no voltage at the gas valve without a call for heat, a relay is stuck on the control board. - Replace the board.	The control senses 24V output to the gas valve at all times. Verify power is not getting to the gas valve from another source. If not , relay is stuck on the board -replace the board
Relay output to HLO energized	Output Relay to Limit Switches Energized without a call for heat	E7.2	1. Check for voltage at the limit switches when there is no call for heat. If voltage is present, check wiring. 2. If E7.2 is still present after verifying no voltage at the limits without a call for heat, a relay is stuck on the board. - Replace the board.	The control senses 24V output from internal relays at all times. If power is detected at the HLO output on the 12 pin plug at any time even without a call for heat E7.2 is displayed.
Low Flame Sense	Flame current is low, but still strong enough to allow operation	E08	E08 would show up in the last 6 fault codes. Check for dirty flame probe. Replace if necessary. Check for a faulty flame sensor.	Control monitors flame current and if low then E08 is reported but will still allow normal furnace operation.
Open Limit Switch Error	Open Limit	E9.1	Check wiring and limit switches	Limit Switch(es) in HLO to HLI detected open during heat cycle
Open Inducer Limit Switch	Open Inducer Limit Switch	E9.2	Check inducer limit switch and wiring.	Open Inducer Limit Switch detected during heat cycle(ILI)
Inducer Communication Error	Inducer or control board has failed	E10	This is an internal board function. Replace the board	This is an internal board function. Replace the board
Internal Gas Valve Error	Failure of gas valve to energize	E11	Replace the Board	Gas valve error. Control monitors the power the gas valve should be using and senses if the valve is open or closed
	Gas valve relay stuck closed			Gas valve error. Control monitors the power the gas valve should be using and can sense if the valve is open or closed
	Failure of HLO output to energize			Relay on the board is not supplying 24V. The control monitors 24V outputs to internal relays. If a relay is not energized in the heat sequence, E11 is displayed on the control.
Open Fuse Error	Open fuse	E12	Check the fuse. If the fuse is good, replace the board. If the fuse is open, check for shorts, and replace the fuse.	If supply voltage of 110V is still be present and the fuse is blown, E12 is displayed on the control.

Table 7. Continued

***SD FAULT CODES AND TROUBLESHOOTING GUIDE**

ALARM	ALARM EXPLANATION	LED BOARD DISPLAY	TROUBLESHOOTING	DESCRIPTION
Pressure Switch #2 and Collector Switch Error	Pressure Switch #2 or collector switch closed at initial call for heat	E3.3	Both inducer and collector switches are shorted closed.	All pressure switches are checked at the beginning of the heat cycle to be open. If the control detects the inducer pressure switch #2 or collector switch(PS2 on the board) closed, the control will display 3.3
	Pressure Switch #2 or Collector Switch opens during heat cycle	E3.4	<ol style="list-style-type: none"> 1. Check for a blocked vent. 2. Check for faulty Inducer Pressure switch #2 or Collector Switch faulty. 3. Pressure switch hoses could be switched. 4. Check the wires, refer to the wiring diagram. 	All pressure switches are checked at the beginning of the heat cycle to be open. The inducer pressure switch #2 and the collector switch control signal is ignored throughout the ignition cycle. The inducer pressure switch #2 and the collector switch is monitored 35 seconds after ignition, both should be closed. If one or both opens after 35 seconds after ignition, Error 3.4 will show on the LED Display and the heat cycle stops.
Pressure Sensor Errors	Pressure Sensor Voltage too low	E4.1	<ol style="list-style-type: none"> 1. Check pressure sensor wire assembly for connection and wire damage. 2. Verify hose is from pressure sensor to the bottom of the air inlet venturi is free of debris and fully connected. 3. Check for faulty pressure transducer. 	Control monitors the voltage from the pressure transducer but ignores low voltage before the inducer is activated. Once the inducer is activated, a voltage from the pressure transducer .2 volts or less is considered low and will show a 4.1 Error code. If the voltage is between .2 and .7 volts and pressure switch #1 fails to close at a call for heat, Error 3.2 is reported
	Pressure Sensor Voltage too high	E4.2	<p>Pressure sensor voltage is reading too high with the inducer not running.</p> <ol style="list-style-type: none"> 1. Check for faulty pressure sensor. 2. Measure the pressure. If the pressure is as expected, replace the pressure transducer. There should not be measurable amount of pressure when furnace is idle. 	At a call for heat the control monitors the pressure sensor voltage. A voltage measured .7 volts or higher will report a 4.2 Error
	Pressure Sensor out of span	E4.3	<ol style="list-style-type: none"> 1. Check for incorrect Pressure Switch #1. 2. Pressure Switch #1 hole partially clogged. 3. Verify hose is from pressure sensor to the bottom of the air inlet venturi is free of debris. 4. Faulty Pressure transducer- replace. 5. Check inducer for blockage. 6. Check for a faulty pressure switch. 	The pressure transducer and Pressure switch #1 work together to ensure the control can continue the ignition sequence. The inducer is initiated, and pressure switch #1 closes. The control board should read pressure transducer voltage output between -.2 and -.7 Volts. If not, the control will report a 4.3 Error code.
	Blocked Vent Detected Error-Inducer RPM Limit exceeded	E4.4	<ol style="list-style-type: none"> 1. Check the vent for proper installation and blockage. 2. Check the inducer wiring/connection. 3. Check for a faulty inducer. 4. Check the condensate drain for a restriction. 	The control will limit the inducer to 4700 RPM. The control will stop the heat cycle if the inducer RPM stays greater than 4700 RPM for 5 seconds.
Flame Sensed when No Flame should Be Present (Internal Lockout)	Flame Sensed when No Flame should Be Present (Internal Lockout)	E05	Check to see if there is a flame present. If so, the check for a faulty gas valve. If no flame is present, control board should be replaced.	The control monitors output voltage to the flame sensor and has detected the presence of voltage when no call for heat is present.
Reversed Polarity Grounding	Voltage reversed polarity	E6.1	Neutral and Hot Wire Switched	The control monitors voltage and can detect a reversed polarity.
	Bad Grounding	E6.2	<ol style="list-style-type: none"> 1. Check all ground wires. 2. Make sure a field Ground is attached to the factory provided stripped end wire 	<ol style="list-style-type: none"> 1. There 5 green grounds 2. Incoming field ground 3. Board ground to chassis 3 on the top right of the control board. Ground to chassis on the 12 pin plug. 4. Inducer ground to chassis 5. Blower motor ground to the blower housing.

Table 7. Continued

Continuous FAN on this unit is limited to TAP 1 or TAP 2 only. Only adjust factory continuous fan setting if necessary. If troubleshooting other speed taps, use the method outlined below using the voltages listed for the tap number being used

Constant Torque Motor Troubleshooting

1. Remove the 6-pin low voltage connector from the furnace control board
2. Apply 24 VAC to Common tap (Blue) and any speed tap on the CTM motor 6-pin plug. The motor should run.

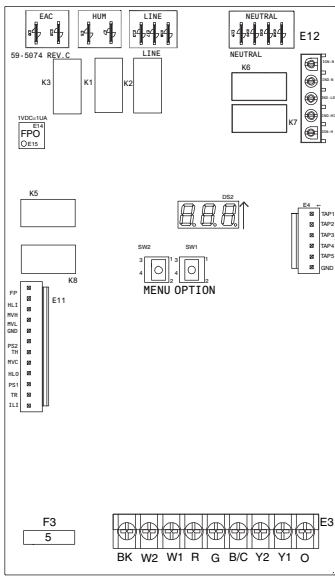

Motor & IFC are Good

6 Pin CTM Motor Connector
 Tap 1 - Low Speed
 Tap 2
 Tap 3
 Tap 4
 Tap 5 - High Speed
 Common

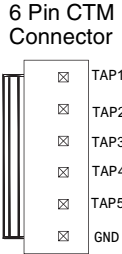

Ensure power is applied to the unit and Seven Segment LED's are ON with no active error codes

Turn fan to ON at thermostat and verify that COF and TP1 alternately appear on the Seven Segment display

Does the motor run?

Verify voltage(s) listed

If voltage is not present, remove 6 pin connector from furnace control board and recheck. If voltage is present, verify voltage at panel connectors and at motor. If voltage is present at the motor, replace the motor

6-Pin low voltage CTM motor connector plug

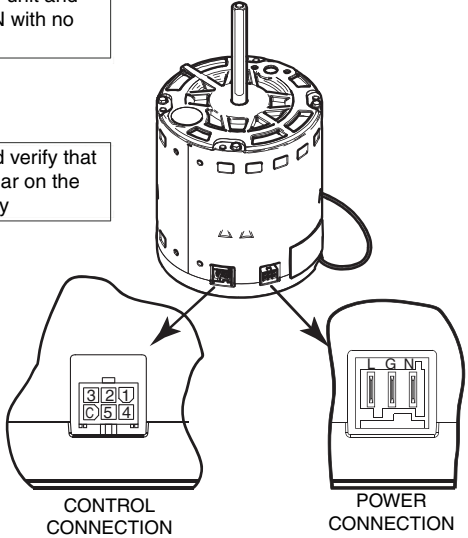
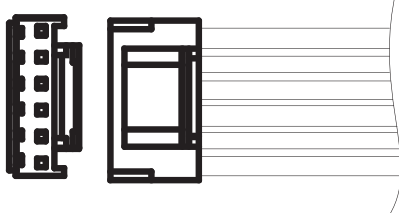

A801X CTM OUTPUT VOLTAGE

RD/W	Tap 1
YL/W	Tap 2
BL/W	Tap 3
BK/W	Tap 4
OR/W	Tap 5
BLUE	24v C

Tap 1	~ 8vdc	
Tap 2	~ 8vdc	
Tap 3	~ 18vdc	
Tap 4	~ 8vdc	
Tap 5	~ 18vdc	
Tap 6 (1 + 2)	~ 8vdc	~ 8vdc
Tap 7 (1 + 3)	~ 8vdc	~ 18vdc
Tap 8 (1 + 4)	~ 8vdc	~ 8vdc
Tap 9 (1 + 5)	~ 8vdc	~ 18vdc

All Voltages Reference Ground

A801X-SF-1B-EN

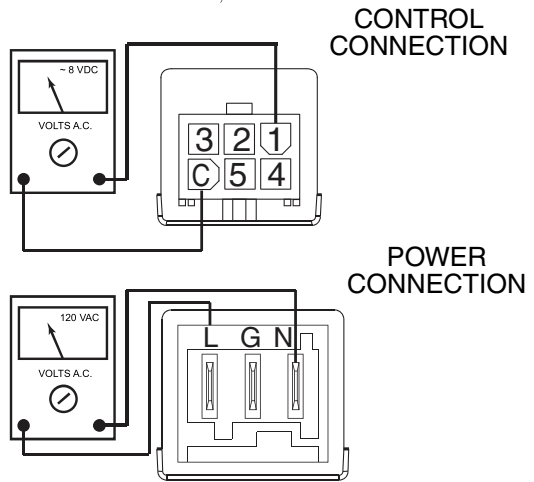

Figure 22. Constant Torque Motor Troubleshooting

FURNACE COMPONENTS

The descriptions below are various functional components that affect the operation and shutting down of this furnace. Some of these components and their locations are shown in [Figure 23](#). If any component of the furnace must be replaced, use only factory authorized replacement parts specified in the Replacement Parts List provided online.

Condensate Drain Switch: The Condensate Drain Switch will shut down the furnace if the condensate drain from the Collector Pan becomes clogged.

Blower Limit Switch: Prevents operation of the blower motor when the blower door is not in place. Line power will still be at the control board when the blower door is not in place.

Flame Sensor: Verifies the presence of a flame. If no flame is detected, the furnace will shut down within 2.5 seconds.

Gas Valve: Controls the flow of gas to the burners. When the gas valve is energized it automatically opens and regulates the gas pressure in the manifold.

Inducer Assembly: Vents products of combustion to the outside.

Pressure Switches: Verifies that the inducer is drawing the combustion gases through the heat exchanger. The pressure switch prevents furnace operation with excessive flue/condensate blockage or improper inducer operation.

Supply Air Limit Switch: Prevents the air temperature leaving the furnace from exceeding the maximum allowable outlet air temperature.

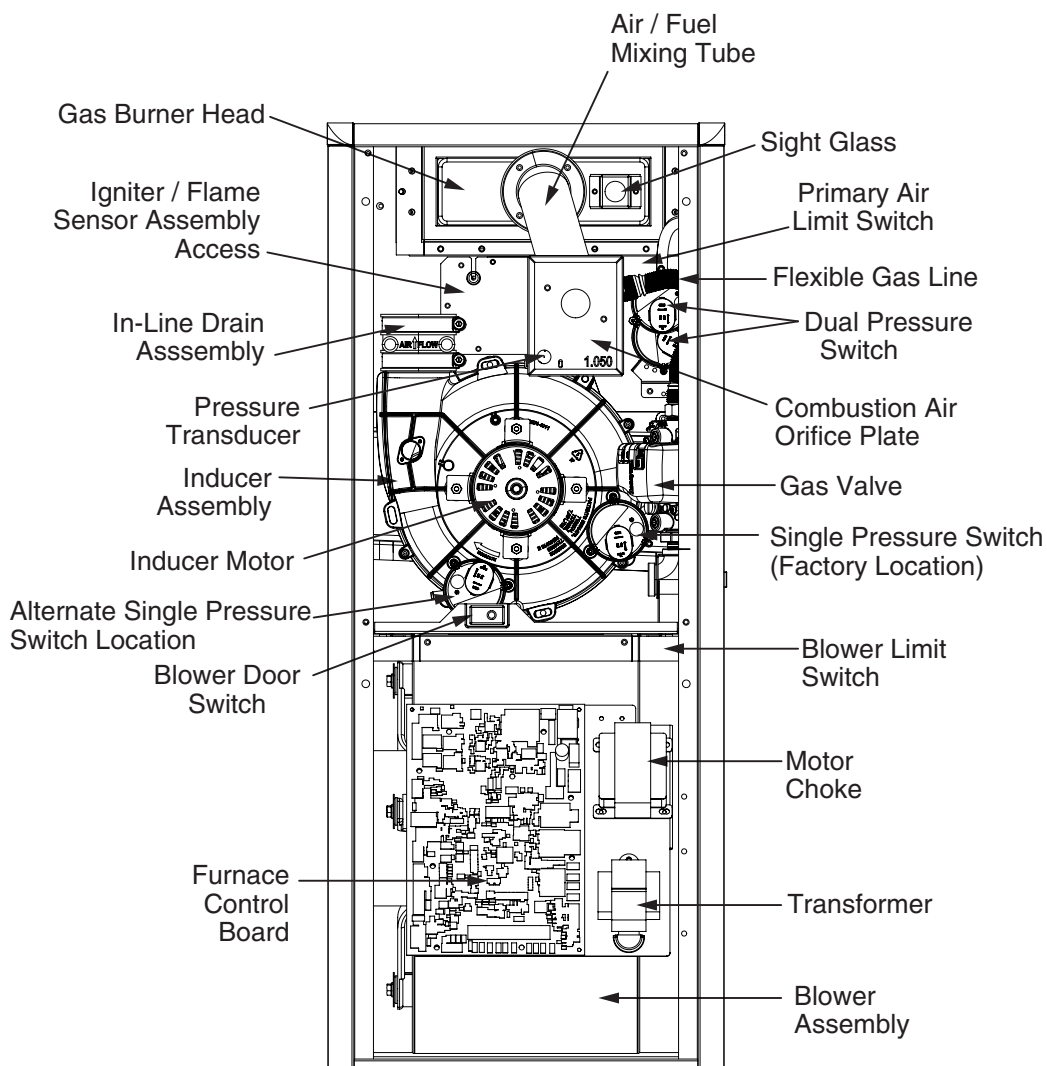

Figure 23. *SD Component Locations

FIGURES & TABLES

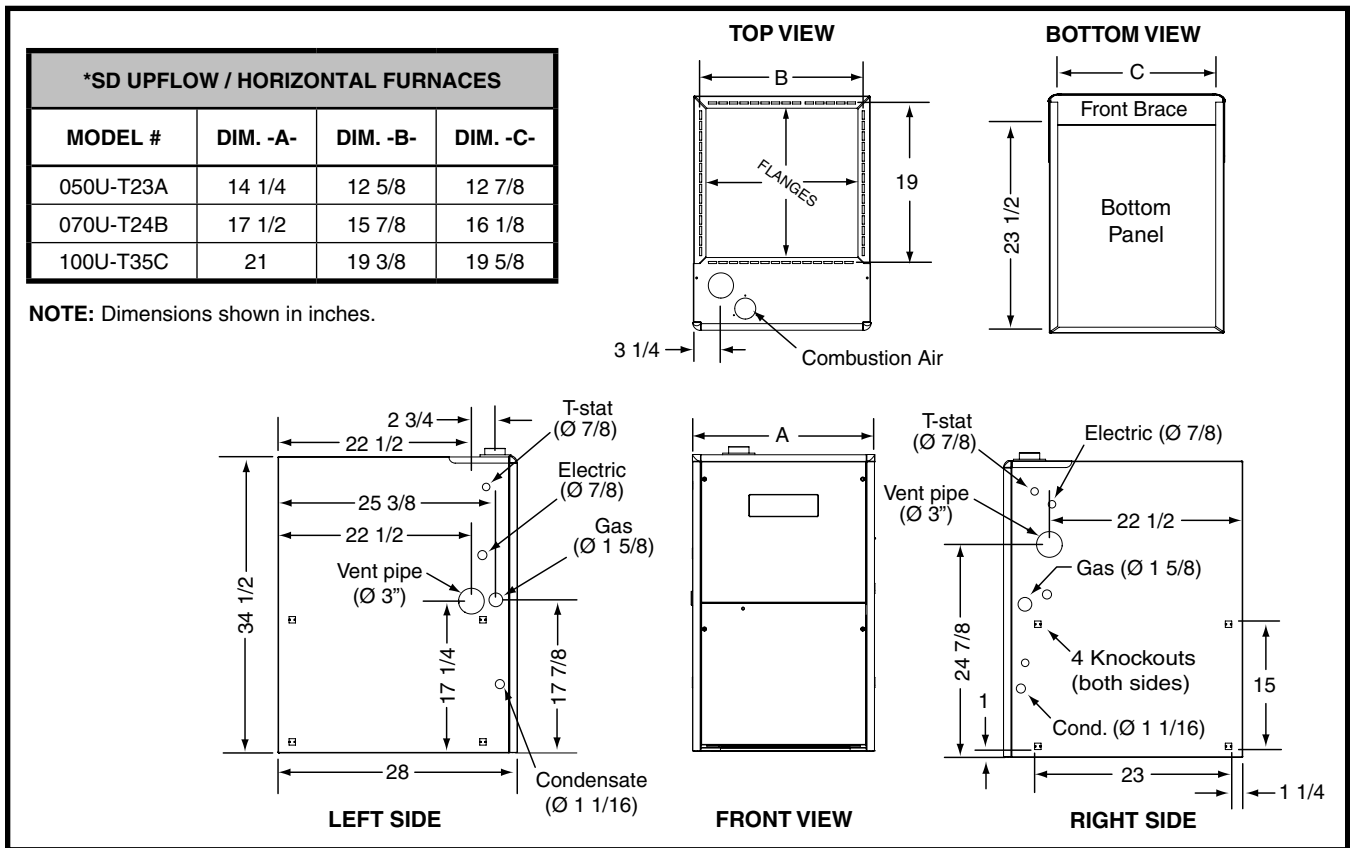

Figure 24. *SD Cabinet Dimensions

Airflow Data

HEATING AIRFLOW (CFM) & TEMPERATURE RISE (°F)												
MODEL NAME/ HEATING INPUT	RETURN AIR VIA:	MOTOR SPEED	EXTERNAL STATIC PRESSURE (IN. W.C.)									
			0.1		0.2		0.3		0.4		0.5	
			CFM	RISE	CFM	RISE	CFM	RISE	CFM	RISE	CFM	RISE
-050U-T23A* 50,000 Btuh Input 48,000 Btuh Output	Bottom	Tap 9										
		Tap 8										
		Tap 7										
		Tap 6*										
		Tap 5**	970	45	935	47	915	48	880	50	845	52
		Tap 4	875	50	835	53	810	54	770	57	735	60
		Tap 3	835	53	795	55	765	57				
		Tap 2										
		Tap 1***										
	Side	Tap 9										
		Tap 8										
		Tap 7										
		Tap 6*										
		Tap 5**	935	47	915	48	880	50	845	52	805	55
		Tap 4	850	52	815	54	780	56	745	59		
		Tap 3	815	54	775	57	740	59				
		Tap 2										
		Tap 1***										

Table 8. *SD 050U-T23A* Blower Data (Heating Airflow)

COOLING AIRFLOW (CFM)										
MODEL NAME HEATING INPUT	RETURN AIR VIA:	MOTOR SPEED	EXTERNAL STATIC PRESSURE (IN. W.C.)							
			0.1	0.2	0.3	0.4	0.5	0.6	0.7	0.8
			(CFM)	(CFM)	(CFM)	(CFM)	(CFM)	(CFM)	(CFM)	(CFM)
-050U-T23A* 50,000 Btuh Input 48,000 Btuh Output	Bottom Only	Tap 9	1,420	1,395	1,360	1,330	1,300	1,280	1,245	1,220
		Tap 8	1,310	1,270	1,245	1,215	1,180	1,145	1,120	1,095
		Tap 7	1,180	1,145	1,115	1,085	1,050	1,020	990	955
		Tap 6 *	1,085	1,050	1,015	985	950	920	890	855
		Tap 5 **	970	935	915	880	845	810	780	745
		Tap 4	875	835	810	770	735	700	665	630
		Tap 3	835	795	765	725	690	655	615	580
		Tap 2	650	590	560	520	465	430	380	340
	Tap 1 ***	550	485	450	405	330	290	250	195	
	Left Side Only (Motor)	Tap 9	1,410	1,380	1,350	1,315	1,285	1,255	1,225	1,200
		Tap 8	1,290	1,260	1,230	1,195	1,160	1,135	1,100	1,070
		Tap 7	1,145	1,115	1,090	1,055	1,030	995	960	920
		Tap 6 *	1,045	1,015	980	950	920	885	855	825
		Tap 5 **	935	915	880	845	805	775	745	695
		Tap 4	850	815	780	745	715	665	625	585
		Tap 3	815	775	740	700	675	620	575	540
Tap 2		605	575	530	495	445	390	325	235	
Tap 1 ***	495	470	410	365	320	260	160			

***NOTES:**

1. Data is shown without filter.
 2. Temperature rises in the table are approximate. Actual temperature rises may vary.
 3. Individual cells shaded in gray indicate a temperature rise outside of the recommended range.
 4. To comply with government mandated efficiency standards, speed settings shaded in gray are not allowed in HEAT mode.
- * Denotes the factory (default) COOL setting.
** Denotes the factory (default) HEAT setting.
*** Denotes the factory (default) FAN setting. If an alternate speed is to be used, refer to the installation instructions for Speed Tap Selection.

Table 9. *SD 050U-T23A* Blower Data (Cooling Airflow)

HEATING AIRFLOW (CFM) & TEMPERATURE RISE (°F)												
MODEL NAME/ HEATING INPUT	RETURN AIR VIA:	MOTOR	EXTERNAL STATIC PRESSURE (IN. W.C.)									
		SPEED	0.1		0.2		0.3		0.4		0.5	
		TAP	CFM	RISE	CFM	RISE	CFM	RISE	CFM	RISE	CFM	RISE
-070U-T24B 70,000 Btuh Input 67,000 Btuh Output	Bottom Only	9										
		8										
		7										
		6**	1,460	42	1,430	43	1,385	45	1,345	46	1,300	48
		5*	1,380	45	1,330	47	1,285	48	1,240	50	1,200	52
		4	1,065	58								
		3										
		2***										
		1										
	Side Only	9										
		8										
		7										
		6**	1,440	43	1,400	44	1,360	46	1,315	47	1,270	49
		5*	1,340	46	1,295	48	1,255	49	1,215	51	1,170	53
		4										
		3										
		2***										
		1										
	Side + Bottom	9										
		8										
		7										
		6**	1,460	42	1,415	44	1,375	45	1,330	47	1,290	48
		5*	1,400	44	1,355	46	1,310	47	1,270	49	1,225	51
		4	1,065	58								
		3										
		2***										
		1										

Table 10. *SD 070U-T24B Blower Data (Heating Airflow)

COOLING AIRFLOW (CFM)										
MODEL NAME/ HEATING INPUT	RETURN AIR VIA:	MOTOR SPEED TAP	EXTERNAL STATIC PRESSURE (IN. W.C.)							
			0.1	0.2	0.3	0.4	0.5	0.6	0.7	0.8
			(CFM)	(CFM)	(CFM)	(CFM)	(CFM)	(CFM)	(CFM)	(CFM)
-070U-T24B 70,000 Btuh Input 67,000 Btuh Output	Bottom Only	9	1,775	1,745	1,705	1,660	1,620	1,580	1,540	1,500
		8	1,640	1,605	1,560	1,525	1,485	1,440	1,400	1,350
		7	1,565	1,525	1,480	1,440	1,390	1,355	1,310	1,260
		6**	1,460	1,430	1,385	1,345	1,300	1,260	1,215	1,175
		5*	1,380	1,330	1,285	1,240	1,200	1,150	1,110	1,065
		4	1,065	1,015	965	920	870	815	755	700
		3	860	770	735	670	610	560	490	460
		2***	660	610	550	460	430	360		
		1	625	550	490	435	365			
	Side Only	9	1,715	1,710	1,675	1,640	1,600	1,565	1,525	1,480
		8	1,600	1,565	1,530	1,490	1,445	1,410	1,370	1,320
		7	1,515	1,480	1,440	1,405	1,360	1,320	1,275	1,230
		6**	1,440	1,400	1,360	1,315	1,270	1,230	1,180	1,130
		5*	1,340	1,295	1,255	1,215	1,170	1,120	1,070	1,020
		4	1,025	980	925	875	820	780	740	680
		3	830	760	700	650	595	525	495	465
		2***	695	600	565	470	400	385		
		1	585	530	490	420	370			
	Side + Bottom	9	1,820	1,785	1,745	1,710	1,665	1,625	1,585	1,540
		8	1,675	1,640	1,600	1,550	1,515	1,480	1,435	1,390
		7	1,585	1,545	1,500	1,460	1,420	1,380	1,340	1,295
		6**	1,460	1,415	1,375	1,330	1,290	1,245	1,205	1,160
		5*	1,400	1,355	1,310	1,270	1,225	1,180	1,135	1,090
		4	1,065	1,010	965	915	850	810	755	710
		3	860	790	735	680	625	550	500	460
		2***	680	600	550	480	420	390		
		1	650	550	500	435	390			

***NOTES:**

1. To comply with government mandated efficiency standards, two openings are required for airflows above 1,600 CFM.
2. Data is shown without filter.
3. Temperature rises in the table are approximate. Actual temperature rises may vary.
4. Individual cells shaded in gray indicate a temperature rise outside of the recommended range.
5. To comply with government mandated efficiency standards, speed settings shaded in gray are not allowed in HEAT mode.

* Denotes the factory (default) COOL setting.

** Denotes the factory (default) HEAT setting.

*** Denotes the factory (default) FAN setting. If an alternate speed is to be used, refer to the installation instructions for Speed Tap Selection.

Table 11. *SD 070U-T24B* Blower Data (Cooling Airflow)

HEATING AIRFLOW (CFM) & TEMPERATURE RISE (°F)												
MODEL NUMBER/ HEATING INPUT	RETURN AIR VIA:	MOTOR SPEED TAP	EXTERNAL STATIC PRESSURE (IN. W.C.)									
			0.1		0.2		0.3		0.4		0.5	
			CFM	RISE	CFM	RISE	CFM	RISE	CFM	RISE	CFM	RISE
-100U-T35C* 100,000 Btuh Input 95,000 Btuh Output	Bottom Only	9										
		8										
		7										
		6*	1,850	48	1,790	49	1,745	50	1,700	52	1,650	53
		5**	1,745	50	1,690	52	1,645	53	1,590	55	1,535	57
		4	1,480	59	1,420	62	1,360	65				
		3										
		2										
		1***										
	Side Only	9										
		8										
		7										
		6*	1,785	49	1,740	51	1,690	52	1,640	54	1,590	55
		5**	1,690	52	1,640	54	1,595	55	1,540	57	1,490	59
		4	1,435	61	1,375	64						
		3										
		2										
		1***										
	Bottom + Side	9										
		8										
		7										
		6*	1,865	47	1,810	49	1,755	50	1,695	52	1,645	53
		5**	1,760	50	1,705	52	1,655	53	1,595	55	1,535	57
		4	1,495	59	1,430	62	1,365	64				
		3										
		2										
		1***										

Table 12. *SD 100U-T35C* Blower Data (Heating Airflow)

COOLING AIRFLOW (CFM)										
MODEL NAME/ HEATING INPUT	RETURN AIR VIA:	MOTOR SPEED TAP	EXTERNAL STATIC PRESSURE (IN. W.C.)							
			0.1	0.2	0.3	0.4	0.5	0.6	0.7	0.8
			CFM	CFM	CFM	CFM	CFM	CFM	CFM	CFM
-100U-T35C* 100,000 Btuh Input 95,000 Btuh Output	Bottom Only	9	2,250	2,250	2,190	2,130	2,080	2,025	1,975	1,915
		8	2,055	2,010	1,970	1,900	1,840	1,790	1,730	1,675
		7	1,900	1,845	1,795	1,750	1,700	1,650	1,575	1,520
		6*	1,850	1,790	1,745	1,700	1,650	1,595	1,535	1,470
		5**	1,745	1,690	1,645	1,590	1,535	1,485	1,420	1,365
		4	1,480	1,420	1,360	1,300	1,230	1,165	1,110	1,055
		3	1,315	1,245	1,170	1,100	1,025	975	915	860
		2	1,140	1,055	975	890	820	765	705	660
		1***	1,025	920	830	745	690	625	580	500
	Side Only	9	2,155	2,110	2,075	2,020	1,975	1,965	1,950	1,900
		8	1,980	1,940	1,890	1,850	1,805	1,760	1,710	1,650
		7	1,835	1,785	1,740	1,685	1,635	1,585	1,545	1,495
		6*	1,785	1,740	1,690	1,640	1,590	1,540	1,490	1,440
		5**	1,690	1,640	1,595	1,540	1,490	1,440	1,390	1,340
		4	1,435	1,375	1,300	1,250	1,195	1,140	1,080	1,020
		3	1,265	1,190	1,140	1,070	1,005	935	875	815
		2	1,095	1,015	945	870	790	715	665	615
		1***	980	905	835	740	665	590	525	440
	Bottom + Side	9	2,245	2,195	2,155	2,095	2,065	2,070	2,015	1,950
		8	2,080	2,030	1,980	1,930	1,880	1,820	1,765	1,705
		7	1,915	1,875	1,820	1,765	1,715	1,655	1,600	1,535
		6*	1,865	1,810	1,755	1,695	1,645	1,585	1,530	1,485
		5**	1,760	1,705	1,655	1,595	1,535	1,480	1,430	1,370
		4	1,495	1,430	1,365	1,290	1,235	1,170	1,115	1,065
		3	1,325	1,245	1,175	1,095	1,035	970	910	855
		2	1,175	1,065	965	900	810	775	705	635
		1***	1,040	930	850	750	680	610	560	475

***NOTES:**

1. To comply with government mandated efficiency standards, two openings are required for airflows above 1,600 CFM.
 2. Data is shown without filter.
 3. Temperature rises in the table are approximate. Actual temperature rises may vary.
 4. Individual cells shaded in gray indicate a temperature rise outside of the recommended range.
 5. To comply with government mandated efficiency standards, speed settings shaded in gray are not allowed in HEAT mode.
- * Denotes the factory (default) COOL setting.
** Denotes the factory (default) HEAT setting.
*** Denotes the factory (default) FAN setting. If an alternate speed is to be used, refer to the installation instructions for Speed Tap Selection.

Table 13. *SD 100U-T35C* Blower Data (Cooling Airflow)

Electrical Information

WIRING DIAGRAM

For High Efficiency Single Stage Ultra Low NOx Furnaces

Refer to the Installation Instructions provided with the furnace for the proper heating and cooling speeds for your application.

120 Volt / 1 Ph. / 60 Hz.

Refer to the Installation Instructions for control error codes.
If any of the original wire supplied with the furnace must be replaced, it must be replaced with wiring material having a temperature of at least 105° C. Use copper conductors only.

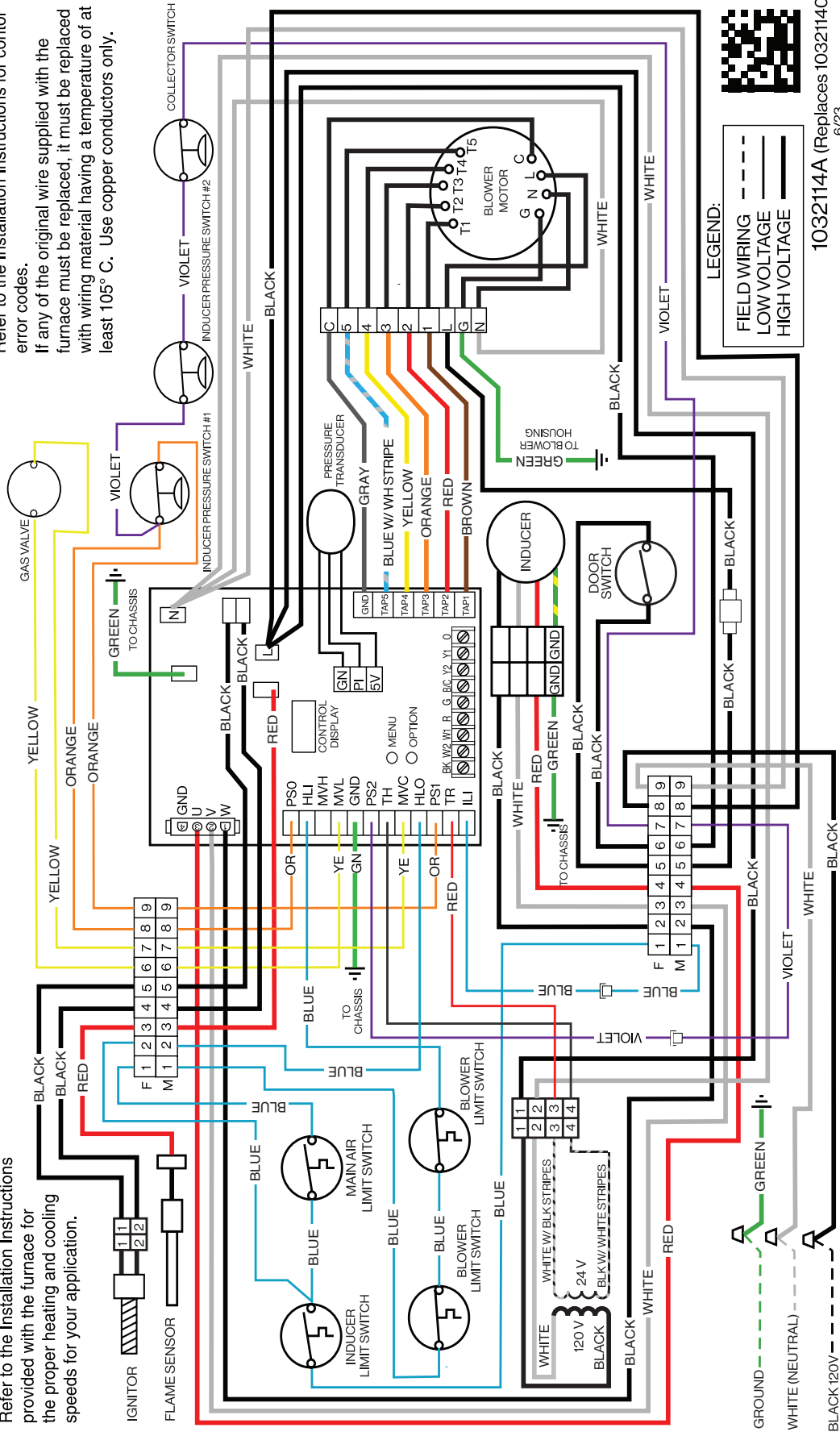
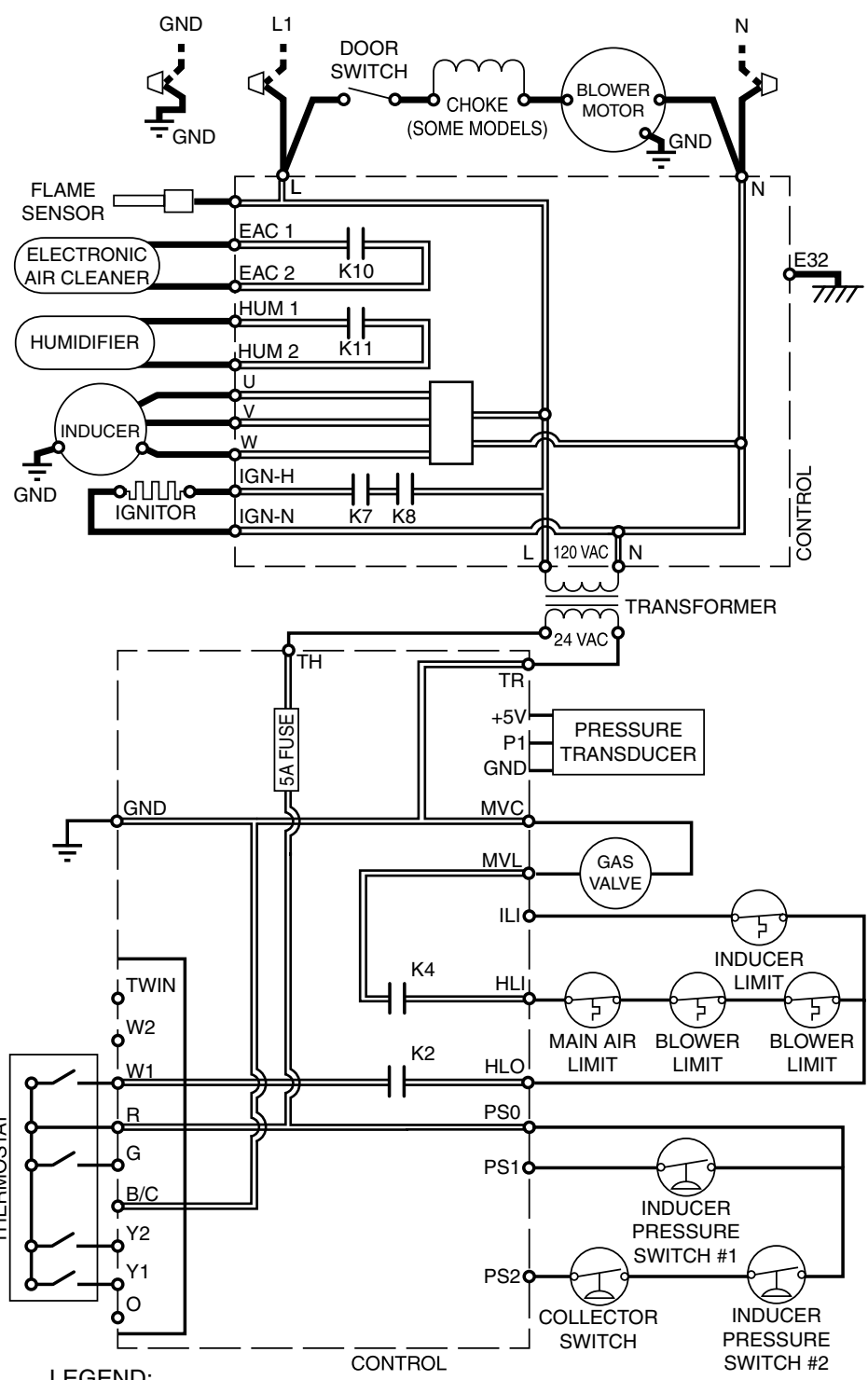

Figure 24. *SD Wiring Diagram

LADDER DIAGRAM

Single Stage Furnace



10350120
(NEW)
 09/2020

Figure 26. *SD Ladder Diagram

Gas Information

GAS FLOW RATES (CUBIC FEET PER HOUR)			
TIME FOR ONE REVOLUTION (SECONDS)	CUBIC FEET PER REVOLUTION OF GAS METER		
	1	5	10
10	360	1,800	3,600
12	300	1,500	3,000
14	257	1,286	2,571
16	225	1,125	2,250
18	200	1,000	2,000
20	180	900	1,800
22	164	818	1,636
24	150	750	1,500
26	138	692	1,385
28	129	643	1,286
30	120	600	1,200
32	113	563	1,125
34	106	529	1,059
36	100	500	1,000
38	95	474	947
40	90	450	900
42	86	429	857
44	82	409	818
46	78	391	783
48	75	375	750
50	72	360	720
52	69	346	692
54	67	333	667
56	64	321	643
58	62	310	621
60	60	300	600
62	58	290	581
64	56	281	563

GAS FLOW RATES (CUBIC FEET PER HOUR)			
TIME FOR ONE REVOLUTION (SECONDS)	CUBIC FEET PER REVOLUTION OF GAS METER		
	1	5	10
66	55	273	545
68	53	265	529
70	51	257	514
72	50	250	500
74	49	243	486
76	47	237	474
78	46	231	462
80	45	225	450
82	44	220	439
84	43	214	429
86	42	209	419
88	41	205	409
90	40	200	400
92	39	196	391
94	38	191	383
96	38	188	375
98	37	184	367
100	36	180	360
102	35	176	353
104	35	173	346
106	34	170	340
108	33	167	333
110	33	164	327
112	32	161	321
114	32	158	316
116	31	155	310
118	31	153	305
120	30	150	300

Table 14. Gas Flow Rates

CAPACITY OF BLACK IRON GAS PIPE (CU. FT. PER HOUR) FOR NATURAL GAS W/ SPECIFIC GRAVITY = 0.60								
NOMINAL PIPE DIAMETER (IN.)	LENGTH OF PIPE RUN (FEET)							
	10	20	30	40	50	60	70	80
1/2	130	90	75	65	55	50	45	40
3/4	280	190	150	130	115	105	95	90
1	520	350	285	245	215	195	180	170
1 1/4	1,050	730	590	500	440	400	370	350
1 1/2	1,600	1,100	890	760	670	610		

Cubic Feet Per Hour Required = $\frac{\text{Input To Furnace (Btu/hr)}}{\text{Heating Value of Gas (Btu/Cu. Ft.)}}$

NOTE:

The cubic feet per hour listed in the table above must be greater than the cubic feet per hour of gas flow required by the furnace. To determine the cubic feet per hour of gas flow required by the furnace, divide the input rate of the furnace by the heating value (from gas supplier) of the gas.

Table 15. Gas Pipe Capacities

Venting Information

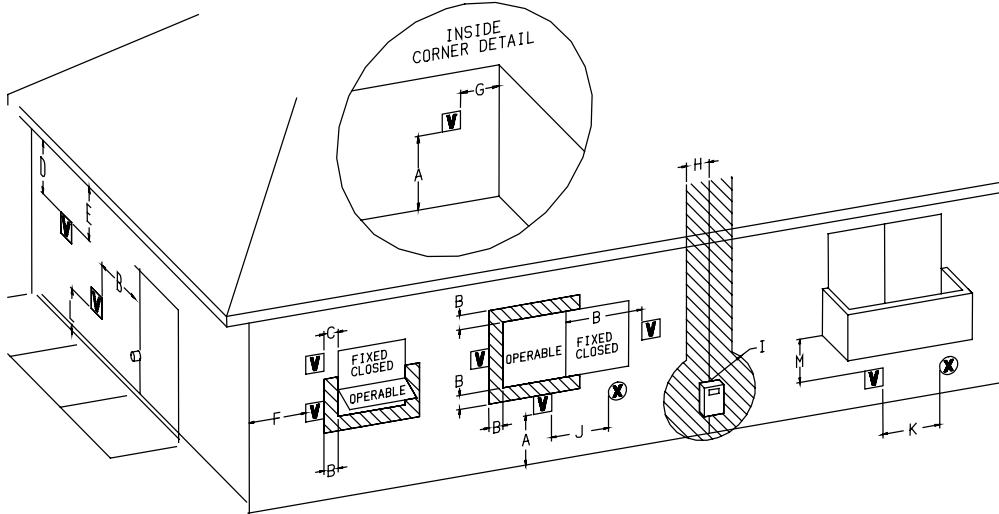

V VENT TERMINAL

X AIR SUPPLY INLET

▨ AREA WHERE TERMINAL IS NOT PERMITTED

CLEARANCE LOCATION		US Installations ^a	
		Direct Vent (2-pipe) Furnaces	Conventional Vent (1-pipe) Furnaces
A =	Clearance above grade, veranda, porch, deck, balcony, or maximum expected snow level.	12 inches (30cm)	12 inches (30cm)
B =	Clearance to window or door that may be opened.	6 inches (15cm) for appliances < 10,000 Btuh (3kW)	4 ft. (1.2m) below or to side of opening; 1 ft. (300mm) above opening
		9 inches (23cm) for appliances 10,000 Btuh - 50,000 Btuh (30kW)	
		12 inches (30cm) for appliances > 50,000 Btuh (30Kw)	
C =	Clearance to permanently closed window	*	*
D =	Vertical clearance to ventilated soffit located above the terminal within a horizontal distance of 2 feet (61cm) from the center line of the terminal.	*	*
E =	Clearance to unventilated soffit.	*	*
F =	Clearance to outside corner.	*	*
G =	Clearance to inside corner.	*	*
H =	Clearance to each side of center line extended above meter/regulator assembly.	*	*
I =	Clearance to service regulator vent outlet.	*	*
J =	Clearance to non-mechanical air supply inlet to building or the combustion air inlet to any other appliance.	6 inches (15cm) for appliances < 10,000 Btuh (3kW)	4 ft. (1.2m) below or to side of opening; 1 ft. (300mm) above opening
		9 inches (23cm) for appliances 10,000 Btuh - 50,000 Btuh (30kW)	
		12 inches (30cm) for appliances > 50,000 Btuh (30Kw)	
K =	Clearance to mechanical air supply inlet.	3 feet (91cm) above if within 10 feet (3m) horizontally	3 ft. (91cm) above if within 10 feet (3m) horizontally
L =	Clearance above paved sidewalk or driveway located on public property.	*	7 ft. (2.13m)
M =	Clearance under veranda, porch, deck, or balcony.	*	*

a: In accordance with the current ANSI Z223.1 / NFPA 54 Natural Fuel Gas Code

* For clearances not specified in ANSI Z223.1 / NFPA 54, the following statement shall be included: "Clearance in accordance with local installation codes, and the requirements of the gas supplier and the manufacturers installation instructions"

Table 16. Vent Termination Clearances

HORIZONTAL VENTING w/ 2-Pipes
(Upflow Furnace Shown)

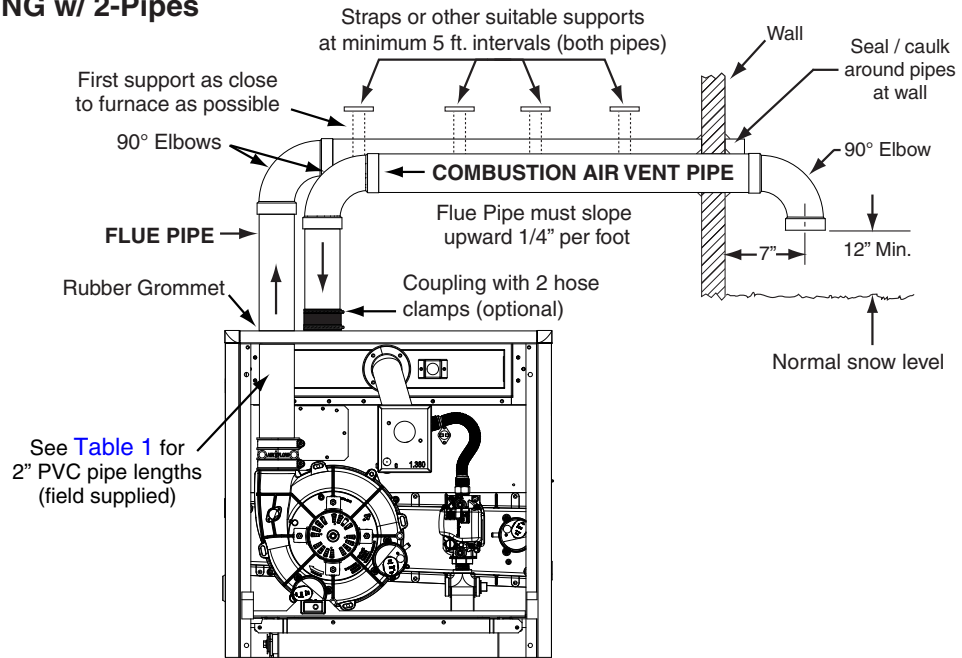

VERTICAL VENTING w/ 2-Pipes
(Upflow Furnace Shown)

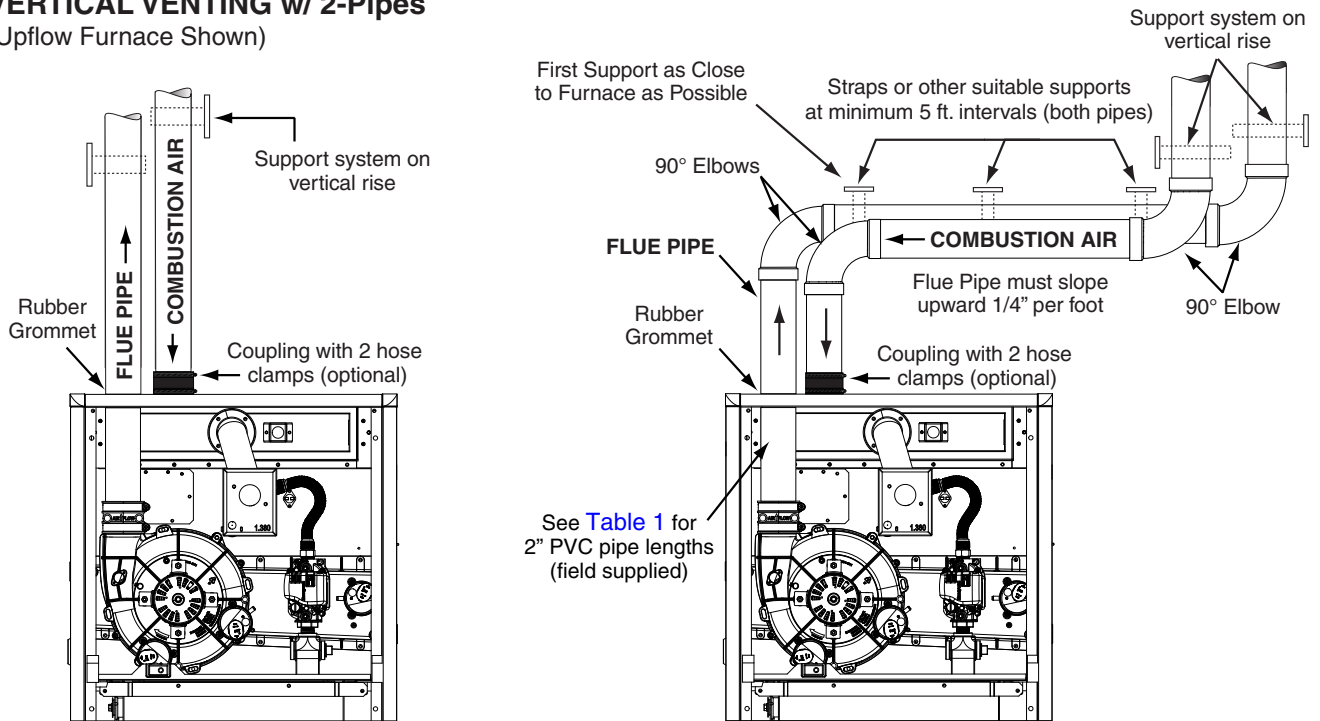
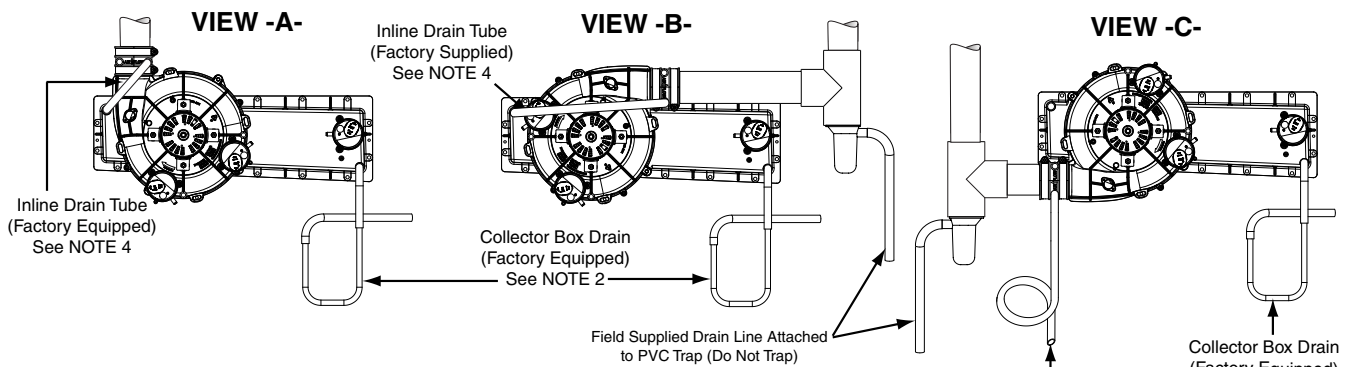
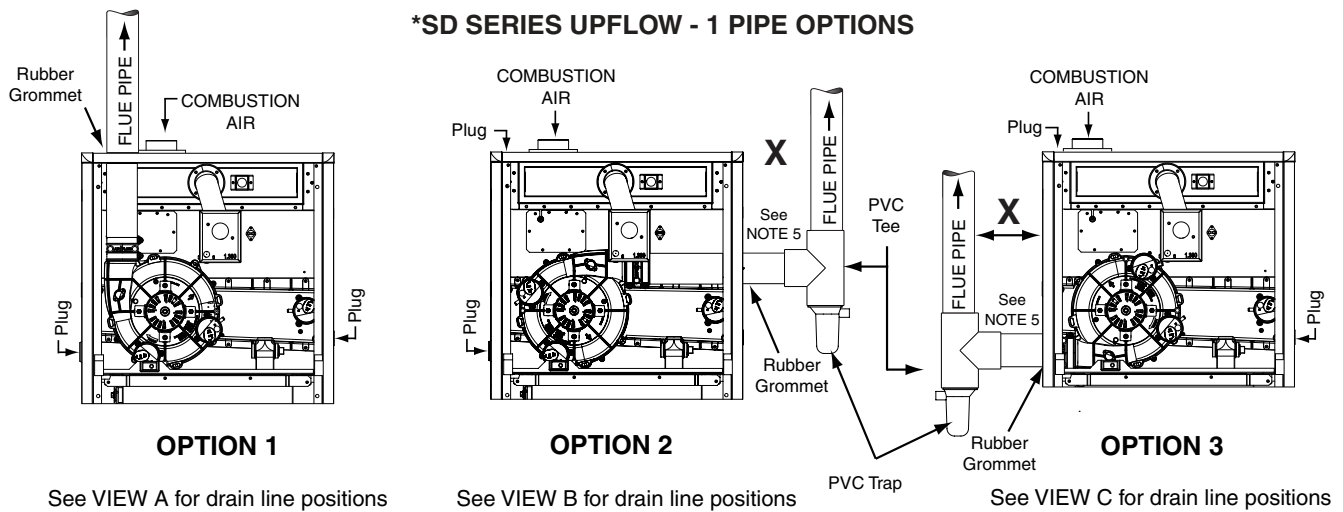

Figure 27. Horizontal & Vertical Venting

***SD SERIES UPFLOW - 1 PIPE OPTIONS**



NOTES:

1. See Accessories section (page 15) for optional PVC Tee configurations and drainage options.
2. Drain lines must be trapped with a J-Trap or field supplied loop. Traps may be positioned inside or outside the cabinet. All drain lines must be routed externally from the cabinet.
3. Inline drain is required only if "X" is greater than 6 feet.
4. Tubing needs to be cut to length and attached during unit installation.
5. Horizontal piping from inducer to flue pipe must be sloped 1/4" per foot to ensure drainage to PVC trap.

***SD SERIES UPFLOW - 2 PIPE OPTIONS**

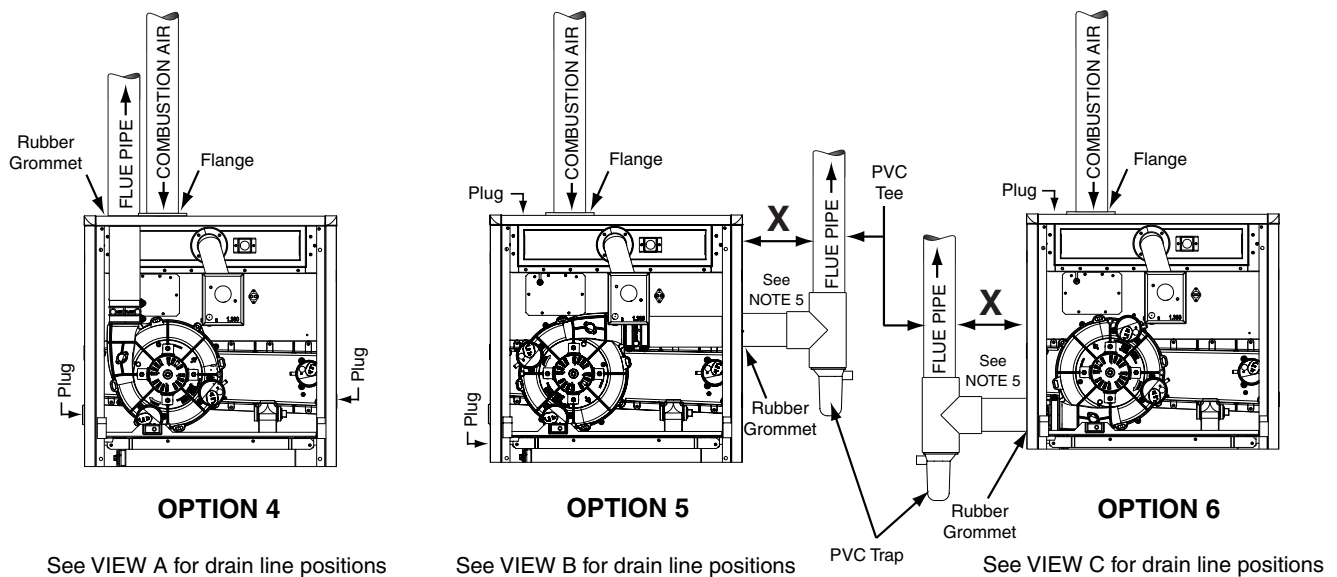
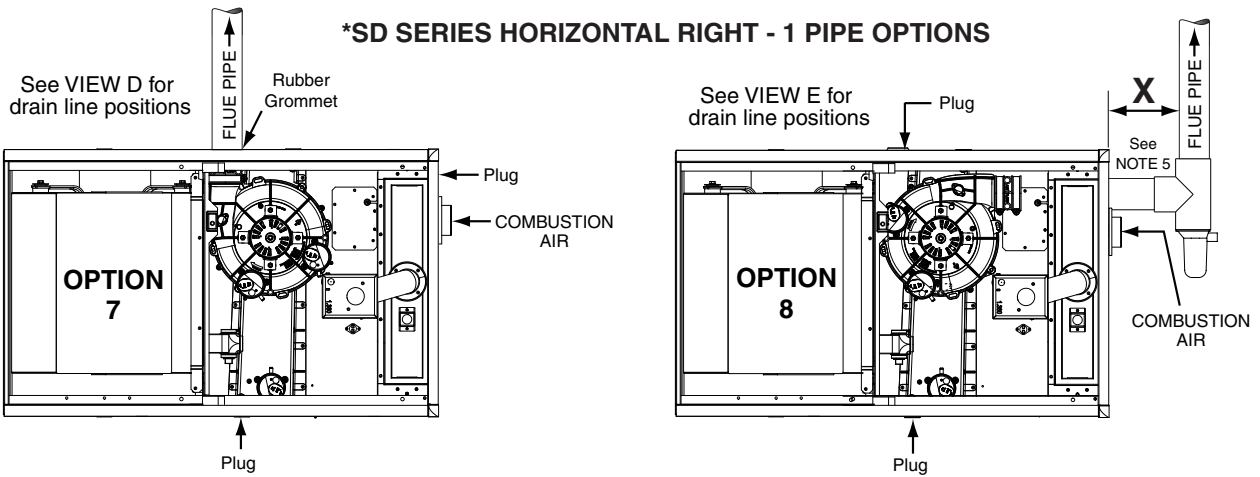
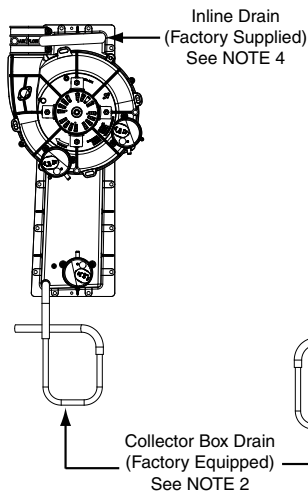

Figure 28. Venting Options for Upflow Installations

***SD SERIES HORIZONTAL RIGHT - 1 PIPE OPTIONS**



VIEW -D-



VIEW -E-

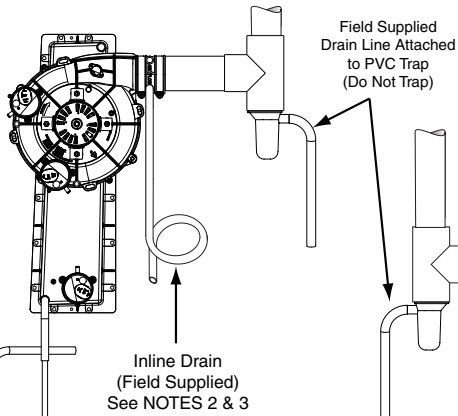

VIEW -F-

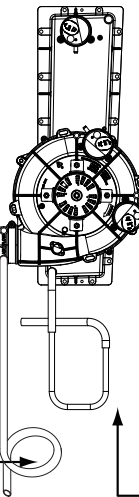

VIEW -G-

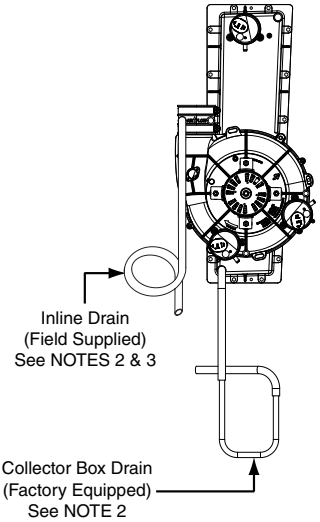

NOTES:

1. See Accessories section (page 15) for optional PVC Tee configurations and drainage options.
2. Drain lines must be trapped with a J-Trap or field supplied loop. Traps may be positioned inside or outside the cabinet. All drain lines must be routed externally from the cabinet.
3. Inline drain is required only if "X" is greater than 6 feet.
4. Tubing needs to be cut to length and attached during unit installation.
5. Horizontal piping from inducer to flue pipe must be sloped 1/4" per foot to ensure drainage to PVC trap.

***SD SERIES HORIZONTAL LEFT - 1 PIPE OPTIONS**

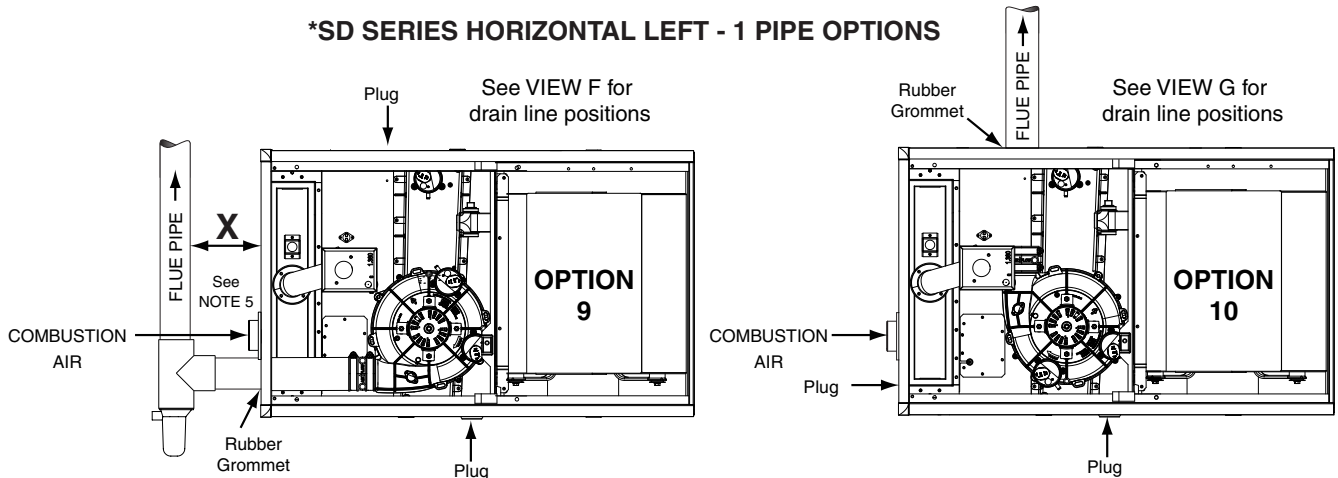
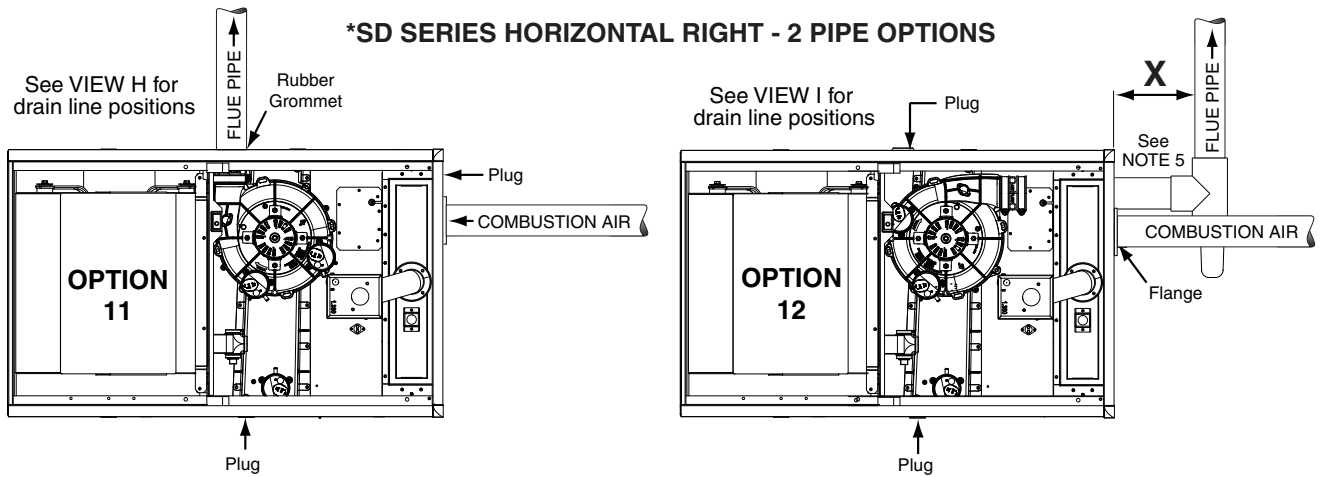
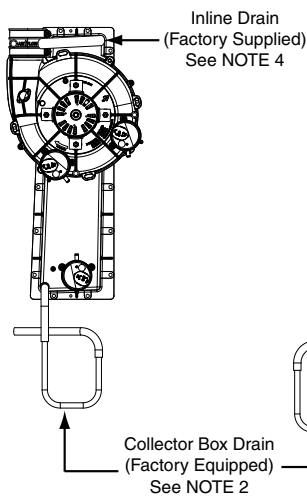

Figure 29. Venting Options for 1 Pipe Horizontal Installations

***SD SERIES HORIZONTAL RIGHT - 2 PIPE OPTIONS**



VIEW -H-



VIEW -I-

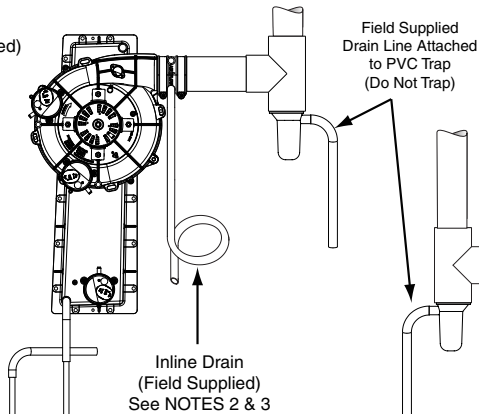

VIEW -J-

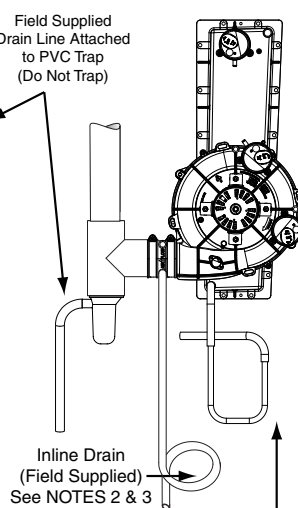

VIEW -K-

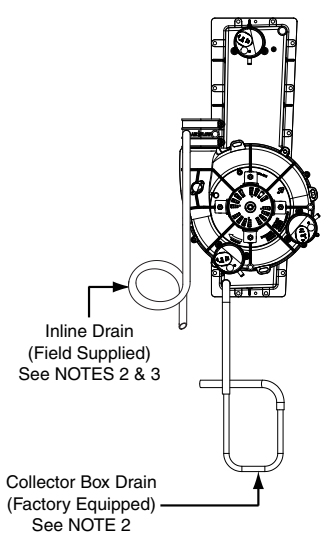

NOTES:

1. See Accessories section (page 15) for optional PVC Tee configurations and drainage options.
2. Drain lines must be trapped with a J-Trap or field supplied loop. Traps may be positioned inside or outside the cabinet. All drain lines must be routed externally from the cabinet.
3. In-line drain is required only if "X" is greater than 6 feet.
4. Tubing needs to be cut to length and attached during unit installation.
5. Horizontal piping from inducer to flue pipe must be sloped 1/4" per foot to ensure drainage to PVC trap.

***SD SERIES HORIZONTAL LEFT - 2 PIPE OPTIONS**

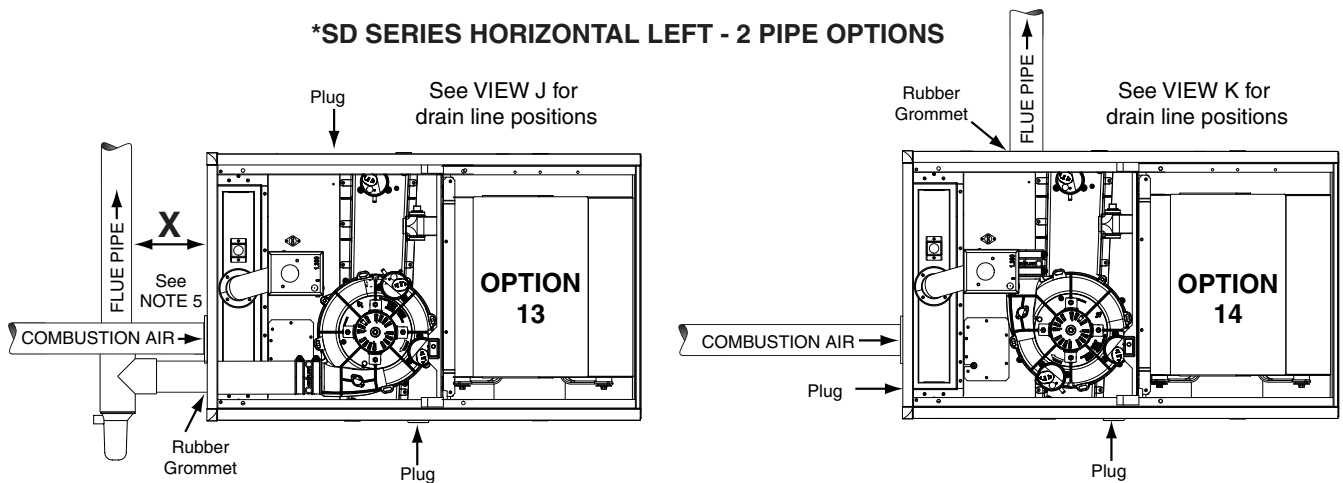
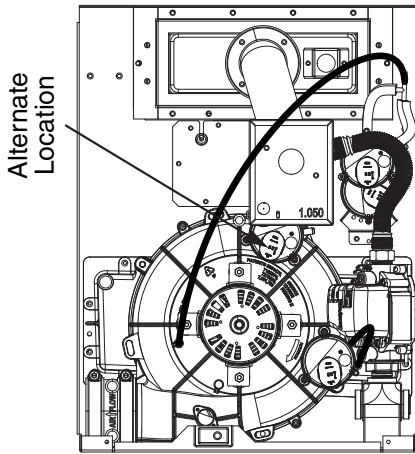

Figure 30. Venting Options for 2-Pipe Horizontal Installations

PRESSURE SWITCH TUBING FOR A50 FURNACES

**Upflow Installation
Inducer Rotated Left**



**Upflow Installation
Inducer Vertical**

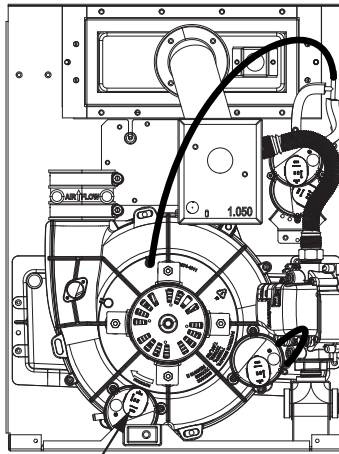

**Upflow Installation
Inducer Rotated Right**

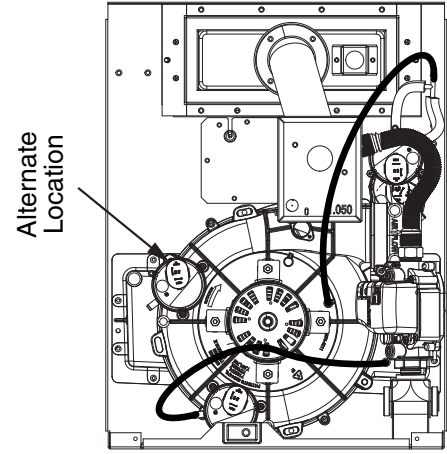

**Horizontal Left Installation
Inducer Vertical**

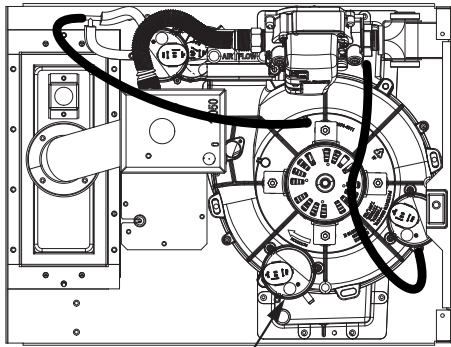

**Horizontal Right Installation
Inducer Vertical**

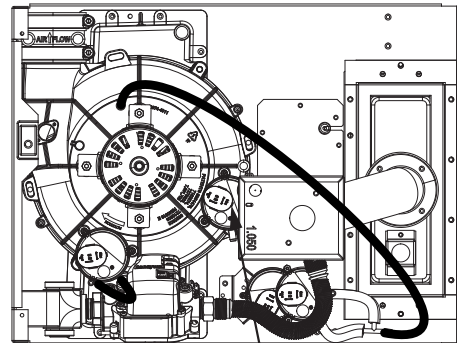

**Horizontal Left Installation
Inducer Rotated Left**

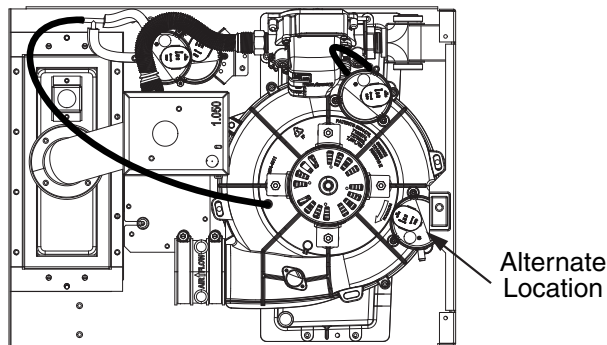

**Horizontal Right Installation
Inducer Rotated Right**

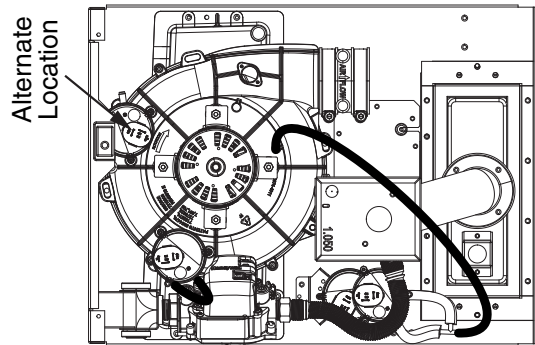
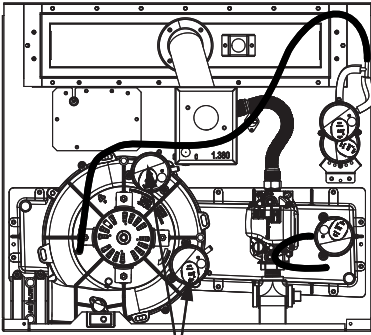

Figure 31. *SD 050U-T23A* & *070U-T24B* Pressure Switch Tube Locations

PRESSURE SWITCH TUBING FOR C100 FURNACES

**Upflow Installation
Inducer Rotated Left**



Alternate Locations

**Upflow Installation
Inducer Vertical**

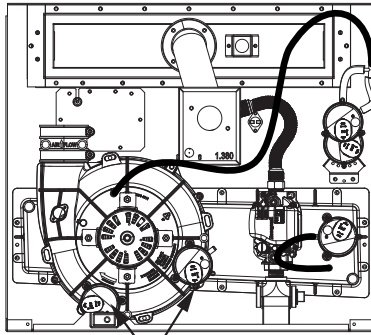

Alternate Locations

**Upflow Installation
Inducer Rotated Right**

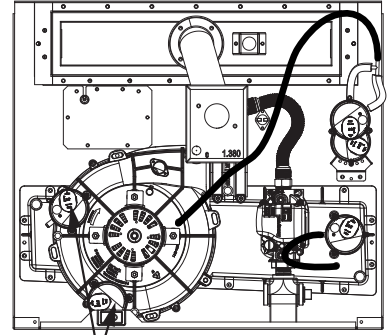

Alternate Locations

**Horizontal Left Installation
Inducer Vertical**

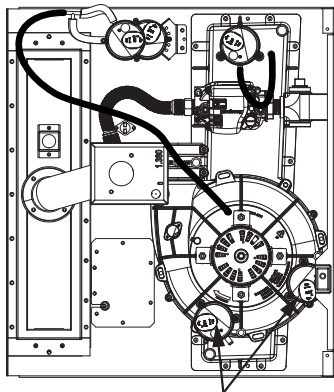

Alternate Locations

**Horizontal Right Installation
Inducer Vertical**

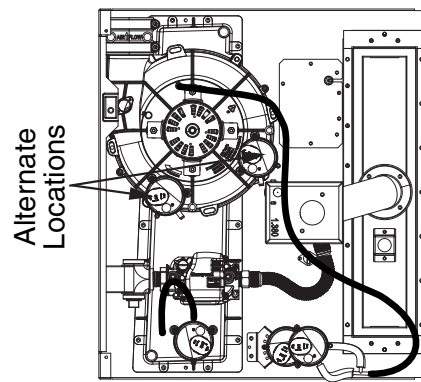

Alternate Locations

**Horizontal Left Installation
Inducer Rotated Left**

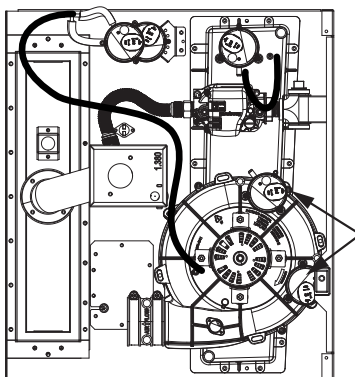

Alternate Locations

**Horizontal Right Installation
Inducer Rotated Right**

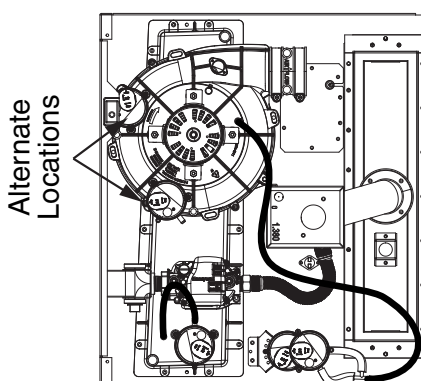

Alternate Locations

Figure 32. *SD 100U-T35C* Pressure Switch Tube Locations

INSTALLATION CHECKLIST

INSTALLER NAME:		
CITY:	STATE:	
INSTALLATION ADDRESS:		
CITY:	STATE:	
UNIT MODEL #		
UNIT SERIAL #		
Minimum clearances per Figure 1 (page 5) ?	YES	NO
Has the owner's information been reviewed with the homeowner?	YES	NO
Has the literature package been left near the furnace?	YES	NO

ELECTRICAL SYSTEM		
Electrical connections tight?	YES	NO
Line voltage polarity correct?	YES	NO
Supply Voltage: VOLTS		
Has the thermostat been calibrated?	YES	NO
Is the thermostat level?	YES	NO
Is the heat anticipator setting correct?	YES	NO

GAS SYSTEM		
Gas Type: (circle one)	Natural Gas	Propane
Gas pipe connections leak tested?	YES	NO
Gas Line Pressure: (in - W.C.)		
Installation Altitude: (FT.)		
Deration Percentage: (%)		
Furnace Input: (Btuh)		
Supply Air Temperature: (° F)		
Return Air Temperature: (° F)		
Temperature Rise: (° F)		

REPLACEMENT PARTS

Replacement parts are available through your distributor. Please have the complete model and serial number of the unit when ordering replacement parts.

ELECTRICAL:

- Gas Valves
- Temperature Limit Switches
- Ignition Controls
- Thermostats
- Ignitors/Flame Sensors
- Transformers
- Pressure Switches

MOTORS:

- Blower Motor
- Inducer Blower Motor

COMPONENTS:

- Blower Assembly
- Burners/Orifices
- Cabinet Panels
- Gaskets
- Heat Exchanger

ATTENTION INSTALLERS:

It is your responsibility to know this product better than your customer. This includes being able to install the product according to strict safety guidelines and instructing the customer on how to operate and maintain the equipment for the life of the product. Safety should always be the deciding factor when installing this product and using common sense plays an important role as well. Pay attention to all safety warnings and any other special notes highlighted in the manual. Improper installation of the furnace or failure to follow safety warnings could result in serious injury, death, or property damage.

These instructions are primarily intended to assist qualified individuals experienced in the proper installation of this appliance. Some local codes require licensed installation/service personnel for this type of equipment. Please read all instructions carefully before starting the installation. Return these instructions to the customer's package for future reference.

COMBUSTION AIR & VENTING SYSTEM		
Is there adequate fresh air supply for combustion and ventilation?	YES	NO
Vent free from restrictions?	YES	NO
Filter(s) secured in place?	YES	NO
Filter(s) clean?	YES	NO
Flue connections tight?	YES	NO
Is there proper draft?	YES	NO

