

INSTALLATION INSTRUCTIONS

C8BV & C8DV SERIES SPLIT SYSTEM UNCASSED INDOOR COILS STRAIGHT & DOWNTURN BRAZED INSTALLATIONS

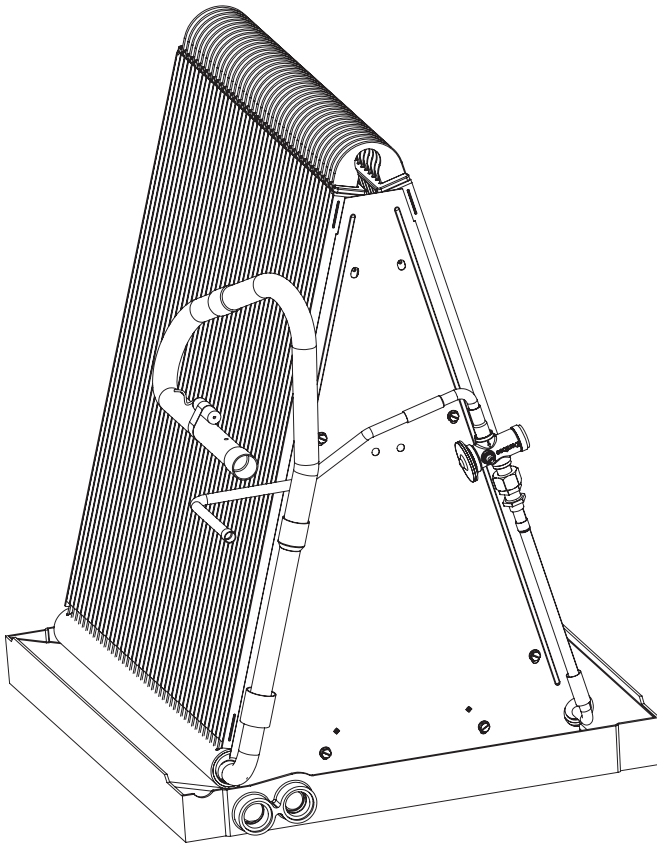

**C8BV Uncased Indoor Coil
(Straight Brazed Connection)**

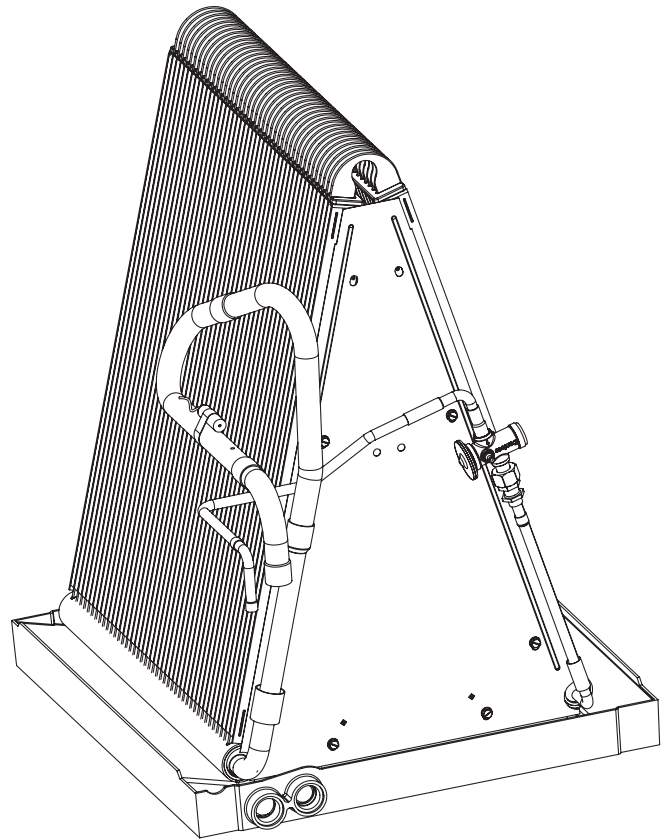

**C8DV Uncased Indoor Coil
(Downturn Brazed Connection)**

IMPORTANT

ATTENTION INSTALLERS:

It is your responsibility to know this product better than your customer. This includes being able to install the product according to strict safety guidelines and instructing the customer on how to operate and maintain the equipment for the life of the product. Safety should always be the deciding factor when installing this product and using common sense plays an important role as well. Pay attention to all safety warnings and any other special notes highlighted in the manual. Improper installation of the coil or failure to follow safety warnings could result in serious injury, death, or property damage.

These instructions are primarily intended to assist qualified individuals experienced in the proper installation of this appliance. Some local codes require licensed installation/service personnel for this type of equipment. Please read all instructions carefully before starting the installation. Return these instructions to the customer's package for future reference.

DO NOT DESTROY. PLEASE READ CAREFULLY & KEEP IN A SAFE PLACE FOR FUTURE REFERENCE.

IMPORTANT SAFETY INFORMATION

Please read all instructions before servicing this equipment. Pay attention to all safety warnings and any other special notes highlighted in the manual. Safety markings are used frequently throughout this manual to designate a degree or level of seriousness and should not be ignored. **WARNING** indicates a potentially hazardous situation that if not avoided, could result in personal injury or death. **CAUTION** indicates a potentially hazardous situation that if not avoided, may result in minor or moderate injury or property damage.

⚠ WARNING:

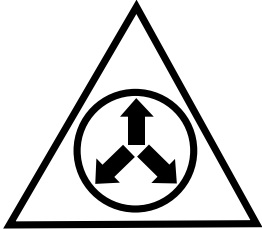

NITROGEN	
HEALTH	1
FLAMMABILITY	0
REACTIVITY	0

0 Minimal Hazard 1 Slight Hazard

C8(B,D)V coils are pressurized with Nitrogen at the factory. Avoid direct face exposure or contact with valve when gas is escaping. Always ensure adequate ventilation is present during the depressurization process. Any uncertainties should be addressed before proceeding.

⚠ WARNING:

This coil must be installed in accordance with the instructions outlined in this manual during the installation, service, and operation of this unit. Unqualified individuals should not attempt to interpret these instructions or install this equipment. If you do not possess mechanical skills or tools, call your local dealer for assistance. Under no circumstances should the equipment owner attempt to install and/or service this equipment. Failure to follow safety recommendations could result in possible damage to the equipment, serious personal injury or death.

⚠ WARNING:

Improper installation, service, adjustment, or maintenance may cause explosion, fire, electrical shock or other hazardous conditions which may result in personal injury or property damage. Unless otherwise noted in these instructions, only factory authorized kits or accessories may be used with this product.

⚠ WARNING:

PROPOSITION 65 WARNING: This product contains chemicals known to the state of California to cause cancer, birth defects or other reproductive harm.

- The installer must comply with all local codes and regulations which govern the installation of this type of equipment. Local codes and regulations take precedence over any recommendations contained in these instructions. Consult local building codes for special installation requirements.
- Familiarize yourself with the controls that shut off the electrical power to the unit. If the unit needs to be shut down for an extended period of time, turn off electrical power at the circuit breaker. For your safety always turn off the electrical power before performing service or maintenance on the unit.
- Installation of equipment may require brazing operations. Installer must comply with safety codes and wear appropriate safety equipment (safety glasses, work gloves, fire extinguisher, etc.) when performing brazing operations.
- Read the Installation Instructions supplied with the air handler. Always observe all safety requirements outlined in this manual and on the air handler markings before installing the coil.
- Follow all precautions in the literature, on tags, and on labels provided with the equipment. Read and thoroughly understand the instructions provided with the equipment prior to performing the installation and operational checkout of the equipment.

GENERAL INFORMATION

C8BV & C8DV series coils are designed for upflow or downflow applications and are equipped with braze type refrigerant connections for easy installation.

- Cooling/heating equipment must be properly sized and installed in accordance with the manufacturer's specifications and approved recommendations.
- Verify that the air delivery of the coil/air handler is adequate to handle the static pressure drop of the coil, filter, and duct work.
- If precise forming of refrigerant lines is required, a copper tubing bender is recommended. Avoid sharp bends and contact of the refrigerant lines with metal surfaces.
- Refrigerant lines should be wrapped with pressure sensitive neoprene or other suitable material where they pass against sharply edged sheet metal.
- Close-off plates are available in some air filter kits. Refer to the Replacement Parts List for available part numbers. Install the necessary close-off plates around the refrigerant lines and drain line where required. Reinstall all inner and outer panels of the coil/air handler that were previously removed when installing the indoor coil.

COIL INSTALLATION

⚠ WARNING:

ELECTRICAL SHOCK OR FIRE HAZARD

Failure to follow safety warnings exactly could result in serious injury or property damage.

Improper servicing could result in dangerous operation, serious injury, death or property damage.

- Before servicing, disconnect all electrical power to the air handler and outdoor unit.
- When servicing controls, label all wires prior to disconnecting. Reconnect wires correctly.
- Verify proper operation after servicing.

⚠ CAUTION:

The coil must be level to ensure proper condensate drainage. An unlevel installation may result in structural damage, premature equipment failure, or possible personal injury.

For recommended BTUH capacities, nominal CFM, and coil dimensions refer to [Figure 2 \(page 5\)](#) and [Table 1 \(page 5\)](#). For matching air handler models refer to [Table 2](#). To install the indoor coil, follow the steps below:

1. Remove door cover plate, door and coil close-off plate (with insulation). Discard door cover plate.
2. **Upflow Applications:** Slide the coil into the track located in the bottom of the unit.
Downflow Applications: The downflow adaptor must be used. Install the downflow adaptor and coil as directed in the instructions supplied with the kit.
3. Reinstall the door and coil close-off plate (with insulation).
NOTE: In downflow applications the door is rotated 180° so that the refrigerant and condensate lines remain on the left side.
4. Install the linesets as outlined in the “Connecting the Linesets” section above. Run the condensate drain according to the guidelines in the “Condensate Drain” section below.

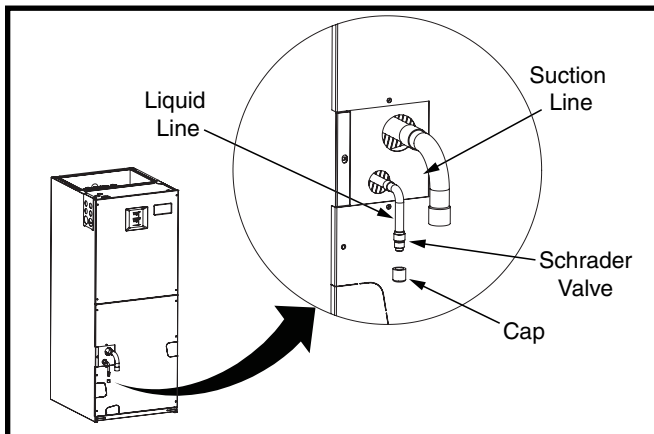

Figure 1. Suction & Liquid Line Locations

Refrigerant Line Connections

System Depressurization

1. Remove the cap ([Figure 1](#)) from the end of the liquid line.
2. Verify pressurization by depressing the Schrader valve on the end of the liquid line. Listen for any escaping gas. If there is no pressure, test the coil for leakage.
 - If leakage is found, clearly mark the location of the leak and return the coil to the distributor for processing.
 - If no leaks are found, the coil may be installed.
3. Depress the valve to relieve all pressure from the coil.

Connecting the Linesets

1. Route and cut both lineset tubes to proper length in accordance with the outdoor unit specifications. Verify the ends are round, clean, and free of any burrs.
2. Cut off the fitting on the 3/8" line of the coil. Swage as needed to fit the line set.
3. Connect the suction and liquid lineset tubes.

⚠ CAUTION:

It is recommended that a wet rag be wrapped around the suction line in front of the close off plate before applying heat. Failure to keep components cool during brazing may result in structural damage, premature equipment failure, or possible personal injury.

4. Braze the individual connections with dry nitrogen flowing through the joints. This will prevent internal oxidation and scaling from occurring.

IMPORTANT: To prevent internal oxidation and scaling from occurring, braze all connections with dry nitrogen flowing through the joints.

5. Wrap the refrigerant lines with pressure sensitive neoprene or other suitable material especially where the lines enter the opening in the sheet metal.
6. Evacuate the system of moisture and non-condensables to prevent low efficiency operation or damage to the unit. The suggested range of evacuation is 250 - 500 microns.
7. Charge the system with refrigerant. **Please Refer to the outdoor unit installation manual for additional charging instructions.**
8. Check the system for leaks, including the lineset and the brazed joints.

NOTE: Apply a soap and water solution on each joint or union with a small paintbrush. If bubbling is observed, the connection is not adequately sealed.

9. Properly dispose of all removed parts.

Condensate Drain

⚠ CAUTION:

The coil must be level to ensure proper condensate drainage. Improper condensate disposal may result in structural damage, premature equipment failure, or possible personal injury.

- Methods for disposing of condensate vary according to local codes. Refer to local codes or authority having jurisdiction for restrictions and proper condensate disposal requirements.
- All condensate pans have primary and secondary drain connections to meet FHA requirements. If the application is located in or above a living space where damage may result from condensate overflow, a separate 3/4 inch drain must be provided from the secondary drain connection and a secondary drain pan must be installed under the entire unit. Run secondary drain lines to a place where they are noticeable if used.
- The coil condensate pan is designed with 3/4" NPSC drain connections. Use a PVC or similar material fitting to attach the drain line to the pan.

NOTE: The fitting should be hand tightened only. Overtightening may crack the drain pan and cause condensate to leak.

- The drain pan **MUST** be drained with factory supplied tubing and looped to form a trap.

IMPORTANT: Failure to install a trap may result in condensation overflowing the drain pan, resulting in substantial water damage to surrounding area.

- Prime the trap with water. Insulate the drain if it is located in an unconditioned space, and test the condensate line for leaks. Consult local codes for additional restrictions or precautions.
- Route the lines to a suitable drain, avoiding sharp bends and pinching of the lines. The drain should maintain a minimum horizontal slope in the direction of discharge of not less than 1" vertical for every 10 ft of horizontal run.
- During system checkout, inspect the drain line and connections to verify proper condensate drainage.

MAINTENANCE & SERVICE

WARNING:

ELECTRICAL SHOCK OR FIRE HAZARD

Failure to follow safety warnings exactly could result in serious injury or property damage.

Improper servicing could result in dangerous operation, serious injury, death or property damage.

- **Before servicing, disconnect all electrical power to the unit.**
 - **When servicing controls, label all wires prior to disconnecting. Reconnect wires correctly.**
 - **Verify proper operation after servicing.**
-

CAUTION:

Do not operate the system without a suitable filter in the return air duct system. Always replace the filter with the same size and type.

To ensure optimum performance and to minimize possible equipment failure, the following maintenance tasks should be performed periodically on this equipment:

1. The air filter installed with the system should be checked and cleaned or replaced twice per year.
2. Check the coil, drain pan, and condensate drain line for cleanliness at the start of each heating and cooling season. Clean as needed.

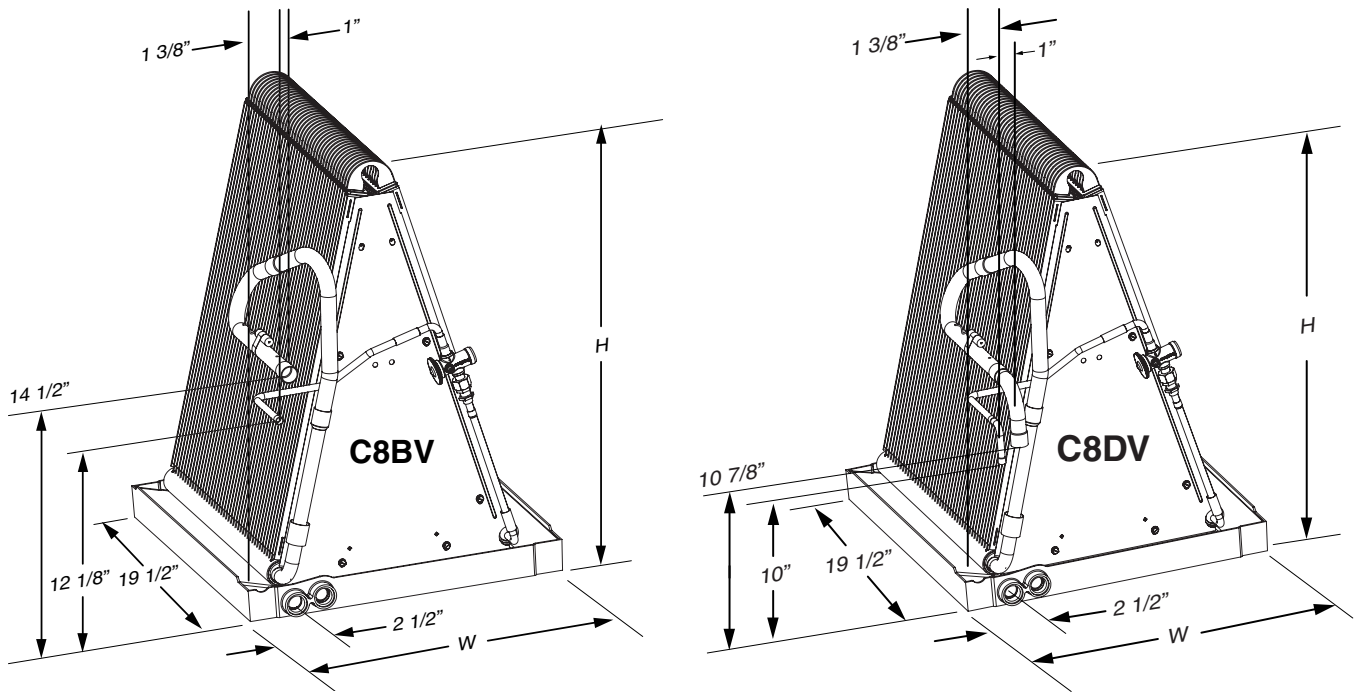

Figure 2. C8BV & C8DV Coil Dimensions

C8(B,D)VM	X36	X42	X48
Nominal Capacity (BTUH)	36,000	42,000	48,000
Nominal Airflow (CFM)	1,200	1,400	1,600
W - Width (in.)	18 1/8	21 1/16	21 1/16
H - Height (in.)	18	24 3/4	28 3/4
Connection - Liquid Line (in.)	3/8	3/8	3/8
Connection - Suction Line (in.)	3/4	7/8	7/8

NOTES:

1. Refer to sales specification sheets for Listed / Certified combinations of equipment and required accessories.
2. Refer to the current AHRI directory for certified ratings of split systems.

Table 1. Coil Specifications

COIL MODEL	AIR HANDLER MODEL
C8BVMX36U-B	B6BV-000K-B-10
	B6BV-000K-B-15
C8DVMX36U-B	B6BV-000K-B-10
	B6BV-000K-B-15
C8BVMX42U-C	B6BV-000K-C-20
C8DVMX42U-C	B6BV-000K-C-20
C8BVMX48U-C	B6BV-000K-C-20
C8DVMX48U-C	B6BV-000K-C-20

Table 2. Air Handler Matches



INSTALLER: PLEASE LEAVE THESE INSTRUCTIONS WITH THE EQUIPMENT OWNER.

