

B6EW Series

INSTALLATION INSTRUCTIONS

Vertical Wall Mount Air Handler



NOTE: Unit style may appear different depending on model.

IMPORTANT

Please read all information in this manual thoroughly and become familiar with the capabilities and use of your appliance before attempting to operate or maintain this unit. These instructions are primarily intended to assist qualified individuals experienced in the proper installation of this appliance. Some local codes require licensed installation/service personnel for this type of equipment. Improper installation, service, adjustment, or maintenance may cause explosion, fire, electrical shock or other hazardous conditions which may result in personal injury or property damage.

Unless otherwise noted in these instructions, only factory authorized kits or accessories may be used with this product. Keep this manual where you have easy access to it in the future. If a problem occurs, check the instructions and follow recommendations given. If these suggestions don't eliminate your problem, call your servicing contractor.

**DO NOT DESTROY. PLEASE READ CAREFULLY AND
KEEP IN A SAFE PLACE FOR FUTURE REFERENCE.**

TABLE OF CONTENTS

Important Safety Information	2
Requirements & Codes	3
General Information	4
Before You Install this Unit	4
Locating the Air Handler	4
Minimum Clearances	4
Operation of Air Handler During Construction	4
Installation in a Garage	5
Plenums & Air Ducts	5
Acoustical Duct Work	5
Unconditioned Spaces	5
Filter Requirements	5
Air Handler Installation	6
Packaging Removal	6
Mounting Applications	6
Connecting Refrigerant Tubing	6
System Depressurization	7
Connecting the Linsets	7
Condensate Drainage	7
Electrical Wiring	8
Line Voltage	8
Grounding	9
Thermostat Connections	9
Configuring Blower Speed for Multi-Speed Units	10
Selecting Continuous Low Speed Fan Operation	10
Startup & Adjustments	11
Before You Start the Unit	11
Air Circulation	11
System Cooling	11
System Heating	11
Unit Maintenance	12
Air Filter(s)	12
Blower Compartment	12
Blower Fan Wheel	12
Blower Motor & Assembly	12
Troubleshooting	12
Figures & Tables	13
Figure 4. B6EW Physical Dimensions	13
Table 7. B6EW Specifications	13
Table 8. Blower Performance Data	14
Wiring Diagrams	15
Figure 5. B6EW 5 kW (1.5, 2, 2.5 & 3 Ton)	15
Figure 6. B6EW 8 kW/10 kW (1.5, 2, 2.5 & 3 Ton) ..	16
Location of Air Handler Components	17
Figure 7. Air Handler Components	17
Installation Checklist	20

IMPORTANT SAFETY INFORMATION

INSTALLER: Please read all instructions before servicing this equipment. Pay attention to all safety warnings and any other special notes highlighted in the manual. Safety markings are used frequently throughout this manual to designate a degree or level of seriousness and should not be ignored. **WARNING** indicates a potentially hazardous situation that if not avoided, could result in personal injury or death. **CAUTION** indicates a potentially hazardous situation that if not avoided, may result in minor or moderate injury or property damage.

WARNING:

ELECTRICAL SHOCK, FIRE OR EXPLOSION HAZARD

Failure to follow safety warnings exactly could result in serious injury or property damage.

Improper servicing could result in dangerous operation, serious injury, death or property damage.

- Before servicing, disconnect all electrical power to air handler.
- When servicing controls, label all wires prior to disconnecting. Reconnect wires correctly.
- Verify proper operation after servicing.

WARNING:

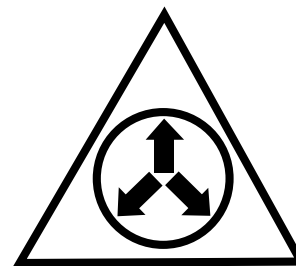

NITROGEN	
HEALTH	1
FLAMMABILITY	0
REACTIVITY	0
0 Minimal Hazard 1 Slight Hazard	

B6EW Air Handlers leave the factory with a nitrogen holding charge. Use caution when preparing coils for field connections. If repairs make it necessary for evacuation and charging, it should only be attempted by qualified, trained personnel thoroughly familiar with this equipment. Some local codes require licensed installation service personnel to service this type of equipment. Under no circumstances should the equipment owner attempt to install and/or service this equipment. Failure to comply with this warning could result in equipment damage, personal injury, or death.

REQUIREMENTS & CODES

WARNING:

This unit must be installed in accordance with instructions outlined in this manual during the installation, service, and operation of this unit. Unqualified individuals should not attempt to interpret these instructions or install this equipment. Failure to follow safety recommendations could result in possible damage to the equipment, serious personal injury or death.

- The installer must comply with all local codes and regulations which govern the installation of this type of equipment. Local codes and regulations take precedence over any recommendations contained in these instructions. Consult local building codes and the National Electrical Code (ANSI C1) for special installation requirements.
- This equipment contains nitrogen gas. Installation or servicing should only be performed by qualified trained personnel thoroughly familiar with this type of equipment.
- All electrical wiring must be completed in accordance with local, state and national codes and regulations and with the National Electric Code (ANSI/NFPA 70) or in Canada the Canadian Electric Code Part 1 CSA C.22.1.
- Installation of equipment may require brazing operations. Installer must comply with safety codes and wear appropriate safety equipment (safety glasses, work gloves, fire extinguisher, etc.) when performing brazing operations.
- Install this unit only in a location and position as specified on pages 4 & 5. This unit is designed only for indoor installations and should be located with consideration of minimizing the length of the supply and return ducts. See Table 8 (page 14) and the rating plate for proper circulating airflow data.
- Follow all precautions in the literature, on tags, and on labels provided with the equipment. Read and thoroughly understand the instructions provided with the equipment prior to performing the installation and operational checkout of the equipment.
- This air handler may be used for temporary heating of buildings or structures under construction. See the guidelines listed on page 4.
- Air handler installations in a residential garage must be installed as specified on page 5.

The information listed below is for reference purposes only and does not necessarily have jurisdiction over local or state codes. Always consult with local authorities before installing any gas appliance.

Duct Systems

- US and CANADA: Air Conditioning Contractors Association (ACCA) Manual D, Sheet Metal and Air Conditioning Contractors National Association (SMACNA), or American Society of Heating, Refrigeration, and Air Conditioning Engineers (ASHRAE) Fundamentals Handbook

Electrical Connections

- US: National Electrical Code (NEC) ANSI/NFPA 70
- CANADA: Canadian Electrical Code CSA C22.1

General Installation

- US: Current edition of the NFPA 90B. For copies, contact the National Fire Protection Association Inc., Batterymarch Park, Quincy, MA 02269; or www.NFPA.org
- CANADA: NSCNGPIC. For a copy, contact Standard Sales, CSA International, 178 Rexdale Boulevard, Etobicoke (Toronto), Ontario, M9W 1R3 Canada

Safety

- US: (NFGC) NFPA 54–1999/ANSI Z223.1 and the Installation Standards, Warm Air Heating and Air Conditioning Systems ANSI/NFPA 90B.
- CANADA: CAN/CGA-B149.1 and .2–M00 National Standard of Canada. (NSCNGPIC)

GENERAL INFORMATION

The unit has been tested and certified by AHRI for capacity and efficiency and will provide many years of safe and dependable comfort, providing it is properly installed and maintained. Abuse, improper use, and/or improper maintenance can shorten the life of the appliance and create unsafe hazards. Please read all instructions before installing the unit.

Before You Install this Unit

- √ This equipment is securely packaged at the time of shipment and upon arrival should be carefully inspected for damage prior to installing the equipment at the job site. Claims for damage (apparent or concealed) should be filed immediately with the carrier.
- √ The cooling load of the area to be conditioned must be calculated and a system of the proper capacity selected. It is recommended that the area to be conditioned be completely insulated and vapor sealed.
- √ Check the electrical supply and verify the power supply is adequate for unit operation. The system must be wired and provided with circuit protection in accordance with local building codes. If there is any question concerning the power supply, contact the local power company.
- √ Verify the air delivery of the air handler is adequate to handle the static pressure drop of the coil, filter, and duct work.

Locating the Air Handler

- Survey the job site to determine the best location for mounting the unit. Consideration should be given to availability of electric power, service access, and noise.
- The dimensions of the room or alcove must be able to accommodate the overall size of the unit and the installation clearances listed in Table 1. Physical dimensions for this air handler are also shown in Figure 4 (page 13).
- The air handler should be installed before routing the refrigerant tubing.

Minimum Clearances

- This appliance must be installed in accordance with clearances listed in Table 1. The air handler must be installed with ample clearance for easy access to the air filter, blower assembly, burner assembly, controls, and vent connections.
- Sufficient clearance for unobstructed airflow through a louvered door must be maintained in order to achieve rated performance.

Operation of Air Handler During Construction

⚠ CAUTION:

Failure to follow these instructions will void the factory warranty and may significantly reduce the life or the performance of the air handler, and/or result in other unsafe conditions. It is the responsibility of the installing contractor to insure these provisions are met.

Operating an air handler in a construction environment can cause the appliance a variety of problems. Proper use of commercial portable space heating equipment during construction is recommended. This air handler may be used during construction if it is not in violation of any applicable codes and the following criteria are met:

- The installation (including electrical supply, gas supply, and duct work), must meet all applicable codes and be permanently installed according to the instructions supplied with the air handler.
- The air handler must be controlled by a properly installed thermostat that complies with the current provisions of the NEC (ANSI/NFPA 70) and all applicable codes having jurisdiction. Thermostat connections must be made in accordance with instructions supplied with the air handler and thermostat.
- The installation must include a properly installed filter in the return air system with no by-pass air. The filter must be inspected frequently and replaced when necessary.
- Return air must be supplied unrestricted and located such that dust and gases from construction activity are not introduced into the circulating air system.
- Before occupying the structure: The filter must be replaced or cleaned, the duct work must be inspected and cleaned of any construction debris, and the furnace

INSTALLATION CLEARANCES	
Left Side..... 0 Inches	Right Side 0 Inches
Back..... 0 Inches	Front..... †See Notes
	
<p>†NOTES:</p> <p><u>Alcove Installations</u> - Allow 24 in. minimum clearance from front of unit to nearest wall or partition for servicing. Recommended clearance is 36 in.</p> <p><u>Closet installations</u> - require a return air grill installed in the door or a partially louvered door across the opening for proper air circulation. For clearances 6" or greater, the closet must have an open free area of 235 in² minimum. For special clearances between 1" - 5", requirements are a louvered door with a minimum of 250 in² (1613 cm²) free area. A fully louvered closet door is strongly recommended for both installation types.</p>	

Table 1. Minimum Unit Clearances

must be cleaned and/or repaired if found to be dirty, damaged, or malfunctioning in any way by a qualified HVAC technician. The air handler shall be inspected and approved by applicable local authority even if this requires redundant inspections.

- The serial number for the air handler used during construction must be submitted in writing (fax and email also acceptable). This information will be used to track the long-term affects of air handler usage during construction. Proof of this submittal shall be available for the final inspection of the air handler prior to occupancy.

Installation in a Garage

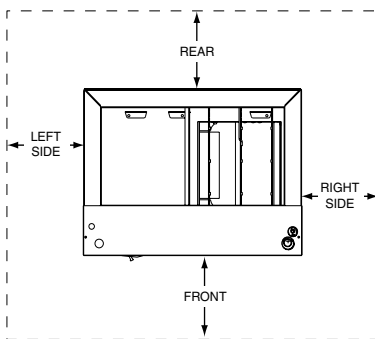
WARNING:

Do not place combustible materials on or against the cabinet. Do not place flammable materials, (gasoline, paint thinners, etc.) or any other flammable vapors and liquids, in the vicinity of the air handler.

The B6EW air handler may be installed in a residential garage with the provision that the unit must be located or protected to prevent physical damage by vehicles.

Plenums & Air Ducts

This unit is designed only for use with a supply and return duct. Air ducts should be installed in accordance with the standards of the National Fire Protection Association Standard for Installation of Air Conditioning Systems (NFPA 90A), Standard for Installation of Residence Type Warm Air Heating and Air Conditioning Systems (NFPA 90B), and all applicable local codes. NFPA publications are available by writing to: National Fire Protection Association, Batterymarch Park, Quincy, ME 02269 or visit www.NFPA.org on the web.

WARNING:

All return ducts must be secured to the air handler with appropriate fasteners. All return ducts must be adequately sealed. When return air is provided through the bottom of the unit, the joint between the air handler and the return air plenum must be air tight.

Return air and circulating air ducts must not be connected to any other heat producing device such as a fireplace insert, stove, etc. This may result in fire, explosion, carbon monoxide poisoning, personal injury, or property damage.

- Plenums and air ducts must be installed in accordance with the Standard for the Installation of Air Conditioning and Ventilating Systems (NFPA No. 90A) or the

Standard for the Installation of Warm Air Heating and Air Conditioning Systems (NFPA No. 90B).

- Design the duct work according to methods described by the Air Conditioning Contractors of America (ACCA).
- The return air duct must have the same free area as the opening provided on the blower coil unit.
- The ducts should be appropriately sized to the capacity of the air handler to ensure its proper airflow rating.
- It is good practice to seal all connections and joints with industrial grade sealing tape or liquid sealant. Requirements for sealing ducts vary from region to region. Consult with local codes for requirements specific to your area.

Acoustical Duct Work

Certain installations may require the use of acoustical lining inside the supply duct work.

- Acoustical insulation must be in accordance with the current revision of the Sheet Metal and Air Conditioning Contractors National Association (SMACNA) application standard for duct liners.
- Duct lining must be UL classified batts or blankets with a fire hazard classification of FHC-25/50 or less.
- Fiber duct work may be used in place of internal duct liners if the fiber duct work is in accordance with the current revision of the SMACNA construction standard on fibrous glass ducts. Fibrous duct work and internal acoustical lining must be NFPA Class 1 air ducts when tested per UL Standard 181 for Class 1 ducts.

Unconditioned Spaces

All duct work passing through unconditioned space must be properly insulated to minimize duct losses and prevent condensation. Use insulation with an outer vapor barrier. Refer to local codes for insulation material requirements.

Filter Requirements

B6EW Air Handlers are supplied with a single air filter when shipped from the factory. Accessing the filter does not require tools and can be removed from the front of the unit. See Unit Maintenance (page 12) for filter sizes and installation information.

WARNING:

Never operate the furnace without a filter in place. Dust and lint can build up on internal components, resulting in loss of efficiency, equipment damage, and possible fire.

AIR HANDLER INSTALLATION

The B6EW Air Handler is shipped ready for vertical upflow installation and can be mounted directly on a wall or recessed between framing studs as shown in Figure 1. Units are also approved for closet or alcove installation with zero clearance to combustibles. See Table 1 (page 4) for required installation clearances. **This appliance is only for indoor use.**

- The unit must be leveled at installation and attached to a properly installed duct system.
- The surface that the air handler is mounted on must provide sound physical support of the unit.
- The air handler must be installed so that all electrical components are protected from water.
- If a louvered door is installed across the front of this unit, the appliance must be mounted flush or behind front edge of finished wall. See Figure 1.

Packaging Removal

Remove the shipping crate and User's Manual from the equipment. Take care not to damage the tubing connections when removing the crate.

Mounting Applications

Units have a bottom and/or front return. Units are shipped for installation in a front return application. Front close-off panel (if supplied) may be discarded. If installed in a bottom return application, attach bottom access panel to the front of the unit below the top service panel.

If the air handler is recessed in a wall, attachment to the framing studs are through the inside of the front flange. For hanging applications, these units are provided with 2-piece offset hanging bracket (Figure 1) attached to the rear of the cabinet. Mounting bracket dimensions are shown in Figure 4 (page 13).

Connecting Refrigerant Tubing

⚠ WARNING:

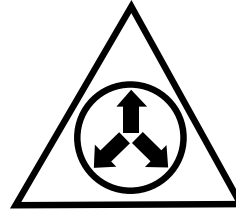

NITROGEN	
HEALTH	1
FLAMMABILITY	0
REACTIVITY	0
0 Minimal Hazard 1 Slight Hazard	

Evaporator Coils are factory shipped with a nitrogen charge. Avoid direct face exposure or contact with valve when gas is escaping. Always ensure adequate ventilation is present during the depressurization process. Address any uncertainties before proceeding. Failure to comply with this warning could result in equipment damage, personal injury, or death.

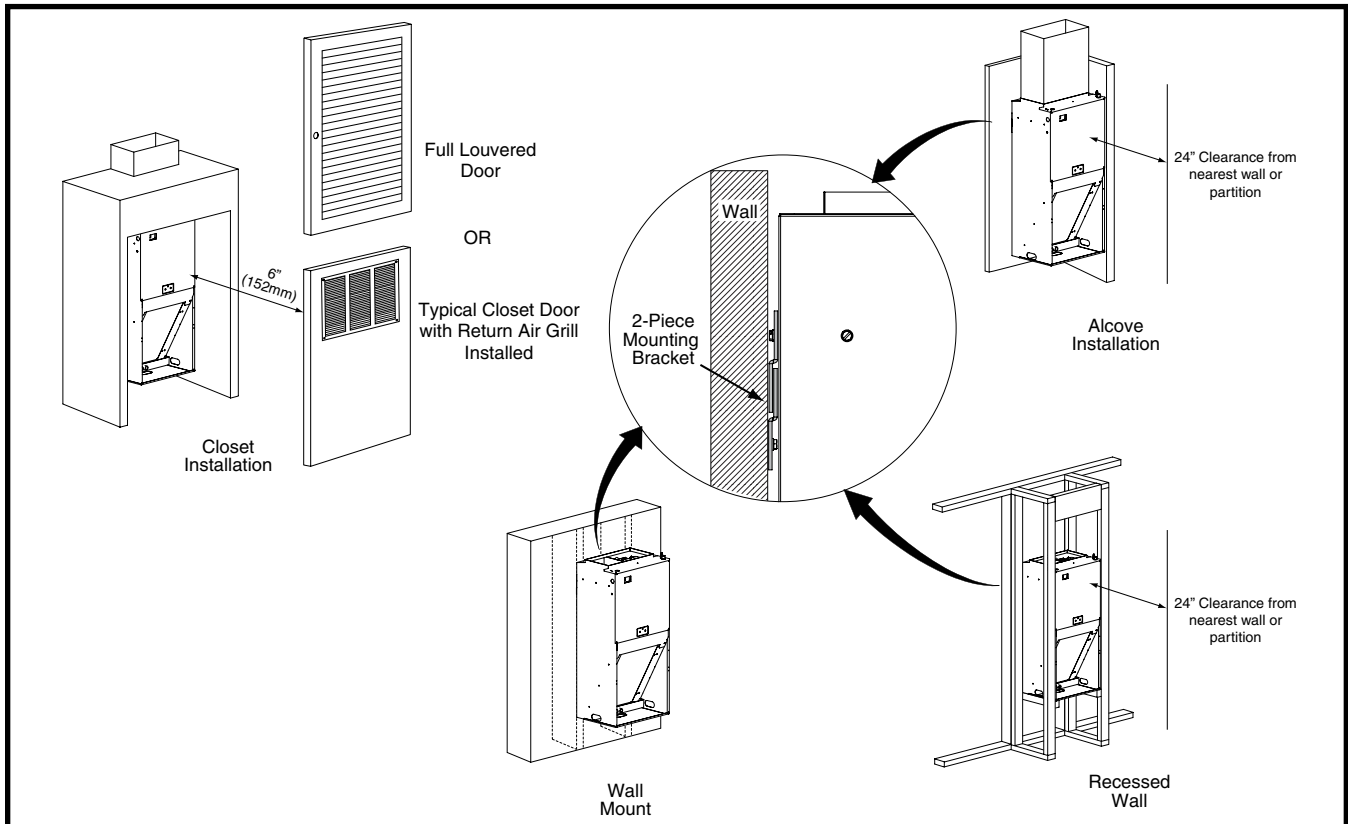

Figure 1. Unit Installation

⚠ CAUTION:

This unit uses refrigerant R-410A. DO NOT use any other refrigerant in this unit. Use of another refrigerant will damage the unit.

- Every effort should be made by the installer to ensure that the field installed refrigerant containing components of the system have been installed in accordance with these instructions and sound installation practices to insure reliable system operation and longevity.
 - Always refer to the installation instructions supplied with the outdoor unit for piping requirements. The suction and liquid lines must be sized in accordance with the condensing unit specifications. See Figure 4 (page 13) for liquid and suction line locations.
 - When connecting refrigerant linesets together, it is recommended that dry nitrogen be flowing through the joints during brazing. This will prevent internal oxidation and scaling from occurring.
 - Refrigerant tubing should be routed in a manner that minimizes the length of tubing and the number of bends in the tubing. It should be supported in a manner that prevents it from vibrating or abrading during system operation. Tubing should be kept clean of foreign debris during installation.
 - If precise forming of refrigerant lines is required, a copper tubing bender is recommended. Avoid sharp bends and contact of the refrigerant lines with metal surfaces.
 - Refrigerant lines should be wrapped with pressure sensitive neoprene or other suitable material where they pass against sharply edged sheet metal.
-

⚠ CAUTION:

Before brazing the B6EW, remove the core from the service port. Failure to comply may result in leakage at the service valve. Replace the core and cap once brazing is complete.

- The B6EW air handler is charged through service valves on the end of the liquid tube for each circuit. These must be removed before brazing the line sets.

System Depressurization

1. Remove the cap from the end of the liquid line.
2. Verify pressurization by depressing the Schrader valve on the end of the liquid line. Listen for any escaping gas. If there is no pressure, test the unit for leakage.
- If leakage is found, clearly mark the location of the leak and return the unit to the distributor for processing.
- If no leaks are found, the air handler may be installed.
3. Depress the valve to relieve all pressure from the coil.

Connecting the Linesets

NOTES: Before proceeding, perform steps 1 - 3 in the System Depressurization section.

1. Route and cut both lineset tubes to proper length in accordance with the outdoor unit specifications. Verify the ends are round, clean, and free of any burrs.
 2. Connect the suction and liquid lineset tubes.
-

⚠ CAUTION:

It is recommended that a wet rag be wrapped around the suction line before applying heat. Failure to keep components cool during brazing may result in structural damage, premature equipment failure, or possible personal injury.

3. Braze the individual connections with dry nitrogen flowing through the joints. This will prevent internal oxidation and scaling from occurring.
4. Wrap the refrigerant lines with pressure sensitive neoprene or other suitable material especially where the lines enter the opening in the sheet metal.
5. Evacuate the system of moisture and non-condensables to prevent low efficiency operation or damage to the unit. The suggested range of evacuation is 250 - 500 microns.
6. Charge the system with refrigerant. Refer to the outdoor unit installation manual for additional charging instructions.
7. Check the system for leaks, including the lineset and the brazed joints. **NOTE:** Apply a soap and water solution on each joint or union with a small paintbrush. If bubbling is observed, the connection is not adequately sealed.
8. Properly dispose of all removed parts.

NOTE: On models which use a TXV, it is recommended to wrap a wet rag around the suction line between the sensing bulb and the line set braze joint before applying any heat.

Condensate Drainage

The drain pan that is supplied with this air handler contains a primary and secondary drain fitting. The condensate is drained from the unit through two 3/4" male pipe fittings located on the front side of the unit as shown in Figure 2 (page 8).

⚠ CAUTION:

The air handler must be level to ensure proper condensate drainage. An unlevel installation may result in structural damage, premature equipment failure, or possible personal injury.

- The method for disposing of condensate varies according to local codes. Consult your local code or authority having jurisdiction.

ELECTRICAL WIRING

WARNING:

ELECTRICAL SHOCK, FIRE OR EXPLOSION HAZARD

Failure to follow safety warnings exactly could result in serious injury or property damage.

Improper servicing could result in dangerous operation, serious injury, death or property damage.

- **Before servicing, disconnect all electrical power to air handler.**
- **When servicing controls, label all wires prior to disconnecting. Reconnect wires correctly.**
- **Verify proper operation after servicing.**

- Electrical connections must be in compliance with all applicable local codes and ordinances, and with the current revision of the National Electric Code (ANSI/NFPA 70).
- For Canadian installations, the electrical connections and grounding shall comply with the current Canadian Electrical Code (CSA C22.1 and/or local codes).

Line Voltage

- **An electrical disconnect must be located within sight of and readily accessible to the unit.** This switch shall be capable of electrically de-energizing the outdoor unit. See unit data label for proper incoming field wiring. Any other wiring methods must be acceptable to authority having jurisdiction.
- It is recommended that the line voltage to the unit be supplied from a dedicated branch circuit containing the correct fuse or circuit breaker for the unit.
- Overcurrent protection must be provided at the branch circuit distribution panel and sized as shown on the unit rating label and according to applicable local codes. See the unit rating plate and Table 2 (page 9) for maximum circuit ampacity and maximum overcurrent protection limits.
- Refer to the unit wiring label for proper high and low voltage wiring.
- Use only copper wire for the line voltage power supply to this unit. Use proper code agency listed conduit and a conduit connector for connecting the supply wires to the unit.
- If replacing any of the original wires supplied with the unit, the replacement wire must be copper wire consisting of the same gauge and temperature rating.
- Provide power supply for the unit in accordance with the unit wiring diagram, and the unit rating plate. The installer should become familiar with the wiring diagram/schematic before making any electrical connections to the unit. See Figures 5 & 6 (pages 15 & 16).

- The drain lines can be routed out the bottom, left or right side of the air handler, but must maintain a downward slope to ensure proper condensate drainage. If the bottom access panel is moved to the front (for bottom return air), the condensate drain tubes must be routed thru one of the side openings. **DO NOT** route the condensate drain tubes thru the front panel.
- Drain pan **MUST** be drained with field supplied tubing and looped to form a trap. Failure to install a trap could result in condensation overflowing the drain pan, resulting in substantial water damage to surrounding area. Both drains must be trapped separately. See Figure 2.
- It is recommended that both drain tubes have a minimum internal diameter of 1/2" and be separately routed to a suitable drain, avoiding sharp bends and pinching of the lines. Refer to local codes and restrictions for proper condensate disposal requirements.
- Both adapters should be made of PVC or similar material and contain a rubber washer. Hand tightened the adapters to the drain pan. **DO NOT** use pliers or any other tools. **Overtightening may crack the drain pan and cause condensate to leak.**
- During system checkout, inspect the drain line and connections to verify proper condensate drainage.

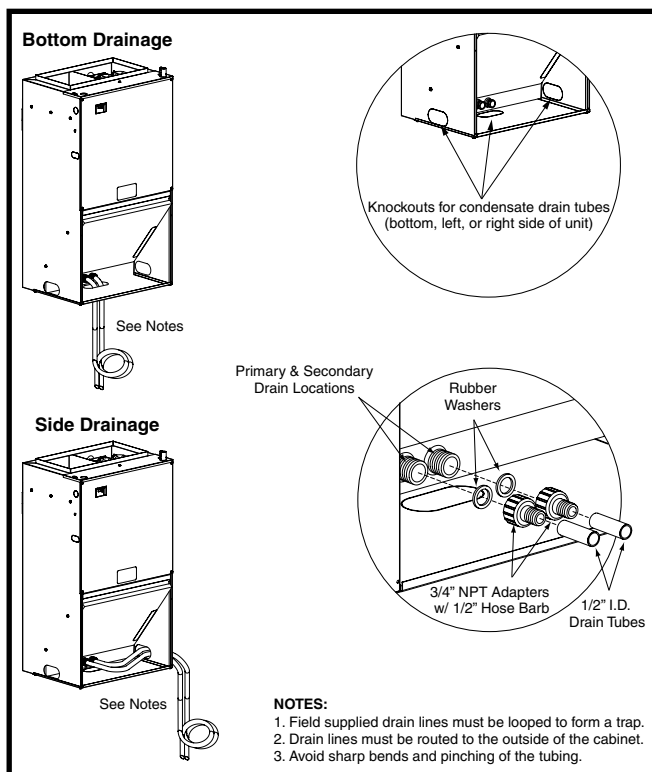

Figure 2. Condensate Drainage

- All 208/230 Volt units are shipped from the factory wired for 240 volt operation. For 208V operation, remove the lead from the transformer terminal marked 240V and connect it to the terminal marked 208V.

Grounding

⚠ WARNING:

The unit cabinet must have an uninterrupted or unbroken electrical ground to minimize personal injury if an electrical fault should occur. Do not use gas piping as an electrical ground!

This unit must be electrically grounded in accordance with local codes or, in the absence of local codes, with the National Electrical Code (ANSI/NFPA 70) or the CSA C22.1 Electrical Code. Use the grounding lug provided in the control box for grounding the unit.

Minimum Circuit Ampacity & Maximum Overcurrent Protection				
Model # B6EW-	240VAC, 50 & 60Hz		208VAC, 50 & 60Hz	
	MCA	MOP	MCA	MOP
X18K-05	29.8	30	26.2	30
X18K-08	43.3	45	38.8	40
X24K-05	29.8	30	26.2	30
X24K-08	43.3	45	38.8	40
X24K-10	54.8	60	47.8	50
X25K-05	29.8	30	26.2	30
X25K-08	44.3	45	38.8	40
X25K-10	54.8	60	47.8	50
X30K-05	29.8	30	26.2	30
X30K-08	44.3	45	38.8	40
X30K-10	54.8	60	47.8	50
X36K-05	29.8	30	26.2	30
X36K-08	44.3	45	38.8	40
X36K-10	54.8	60	47.8	50

MCA = Minimum Circuit Ampacity, MOP = Maximum Over-Current Protection

Table 2. Electrical Rating Data

Thermostat Connections

- Thermostat connections shall be in accordance with the instructions supplied with the thermostat and the indoor equipment. The low voltage wires must be properly connected to the units low voltage terminal block.
- A single stage thermostat is used with this equipment and must operate in conjunction with any installed accessories. Typical AC and air handler hookups are shown in Figure 3.
- The thermostat should be mounted about 5 feet above the floor on an inside wall. DO NOT install the thermostat on an outside wall or any other location where its operation may be adversely affected by radiant heat from fireplaces, sunlight, or lighting fixtures, and convective heat from

warm air registers or electrical appliances. Refer to the thermostat manufacturer’s instruction sheet for detailed mounting and installation information.

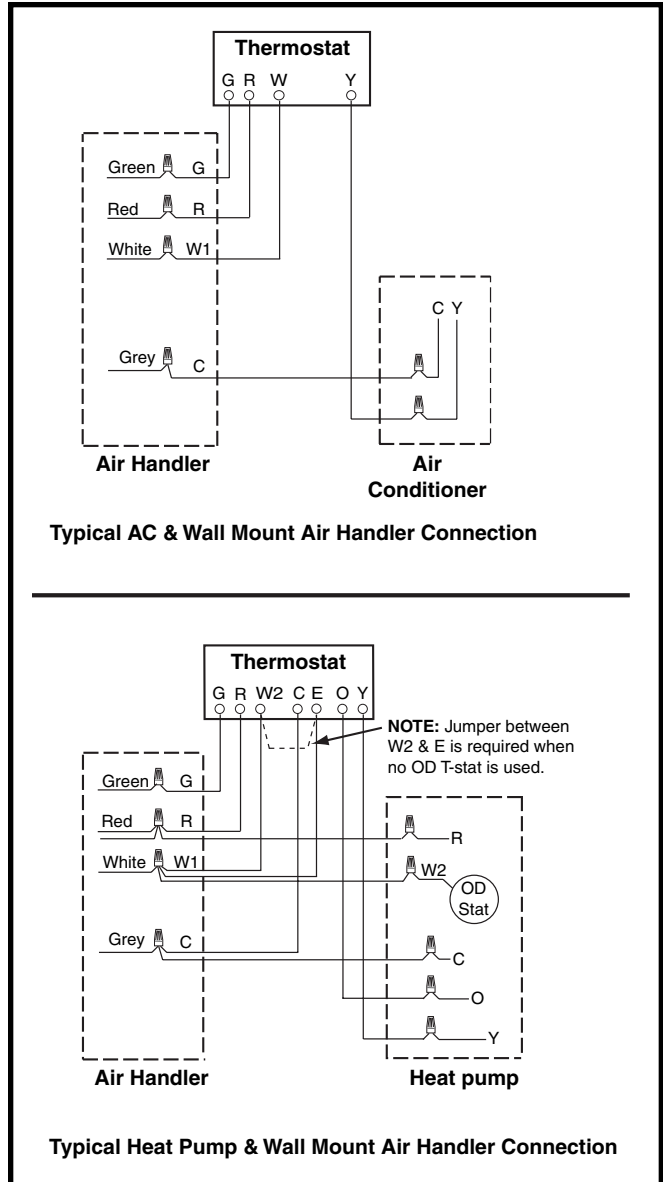

Figure 3. Typical Thermostat Connections

Configuring Blower Speed for Multi-Speed Units

The blower speed is preset at the factory for operation at the same speed for heating and cooling, by using the jumping terminal on the blower motor and connecting it to the desired speed with both the red and black wires connected to the jumping terminal.

CAUTION:

To avoid personal injury or property damage, make sure the motor leads do not come into contact with any uninsulated metal components of the unit.

For optimum system performance and comfort, it may be necessary to change the factory setting speed. See Table 8 (page 14) for airflow data.

1. Disconnect all electrical power to the unit and remove the upper door.
2. Change DIP switch according to desired blower speed. See Table 3 for DIP switches setting.

5 Speed Motor Terminals

- Terminal M1 = Low speed
- Terminal M2 = Medium Low speed
- Terminal M3 = Medium speed
- Terminal M4 = Medium Hi speed
- Terminal M5 = Hi speed

CAUTION:

To prevent overheating of the air handler, make sure the DIP switch is not in the M1 position when the heater is operating at 10kW.

3. Replace the upper door and secure it to the unit.
4. Restore power to the unit.

Selecting Continuous Low Speed Fan Operation (Standard Blower)

The air handler is equipped with the option of continuous low speed fan operation. When **G** is energized without **Y/Y2**, the air handler will operate using the cooling speed. With **G & Y/Y2** or **Y/Y2** is energized, the air handler will operate in the selected cooling speed (including 40 sec blower-off delay).

SET	HEAT					COOL				
	5	4	3	2	1	1	2	3	4	5
M1	Off	Off	Off	Off	On	On	Off	Off	Off	Off
M2	Off	Off	Off	On	Off	Off	On	Off	Off	Off
M3	Off	Off	On	Off	Off	Off	Off	On	Off	Off
M4	Off	On	Off	Off	Off	Off	Off	Off	On	Off
M5	On	Off	Off	Off	Off	Off	Off	Off	Off	On

Table 3. DIP Switch Setting

Control Signal & MODE	Operation	Total kW	Board Action
W (EHEAT)	ON	5 kW	Stage 1 Heat on instantly Heat blower on after 3 second delay
		8 kW/10 kW	Stage 1 Heat on instantly Heat blower on after 3 second delay Stage 2 Heat on after 5 seconds delay
	OFF		Heat stages off instantly Blower off after 15 second delay
W & Y (AUX HEAT)	ON	5 kW	Stage 1 Heat on instantly Cool blower on after 3 second delay
		8 kW/10 kW	Stage 1 Heat on instantly Cool blower on after 3 second delay Stage 2 Heat on after 5 seconds delay
	OFF		Heat stages off instantly Heat blower turns off after 40 second delay
G (FAN)	ON		Cool blower on after 3 second delay
	OFF		Cool blower off instantly
Y (HP & COOL)	ON		Cool Blower on after 3 second delay
	OFF		Cool Blower off after 40 second delay

Table 4. Control Board Operation

STARTUP & ADJUSTMENTS

WARNING:

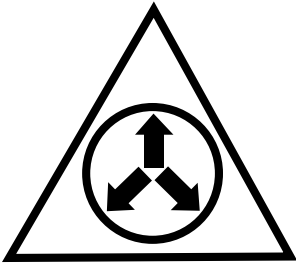

NITROGEN	
HEALTH	1
FLAMMABILITY	0
REACTIVITY	0
0 Minimal Hazard 1 Slight Hazard	

The evaporator coil is shipped from the factory with a nitrogen charge. Use caution when preparing coils for field connections. If repairs make it necessary for evacuation and charging, it should only be attempted by qualified, trained personnel thoroughly familiar with this equipment. Some local codes require licensed installation service personnel to service this type of equipment. Under no circumstances should the equipment owner attempt to install and/or service this equipment. Failure to comply with this warning could result in equipment damage, personal injury, or death.

Before You Start the Unit

Prior to start-up, complete the following inspections:

- √ Verify the unit is level and mounted securely to the wall. Also make sure the air handler is properly located with adequate clearances for servicing the unit as listed in Table 1 (page 4).
- √ Check condensate drain line(s) for proper drainage.
- √ Verify the surrounding area and top of the unit is free from obstructions and debris.
- √ Check all duct connections. Make sure the duct work is adequately sealed to prevent air leakage.
- √ Check all coil connections for leaks.
- √ Verify that the line voltage power leads are securely connected and the unit is properly grounded.
- √ Verify the thermostat is wired correctly. Make sure all low voltage wires are securely connected to the correct leads of the low voltage terminal strip.
- √ Verify the power supply branch circuit overcurrent protection is sized properly.
- √ Verify filter is properly and securely installed.

IMPORTANT: Before you start the unit, perform the following procedures to install the initial charge on units that are factory shipped with a nitrogen holding charge:

1. Read all installation instructions first.
2. Purge the nitrogen holding charge.
3. Evacuate the unit to 350 - 500 microns.
4. Allow the unit to remain under vacuum for at least 30 minutes.

5. Inspect the unit rating plate for the proper type of refrigerant and quantity.
6. Weigh in the proper amount of new (or reclaimed) refrigerant.

Air Circulation

Running the Blower Continuously

Set the thermostat's system mode to **OFF** and the thermostat's fan mode to **ON**. The blower motor should run continuously. Check for air delivery at the register(s). Ensure that there are no obstructions at the registers or in the ducts.

Turning the Blower Off

Set thermostat's fan mode to **AUTO**, the blower will shut down immediately.

System Cooling

1. Set the thermostat's system mode to **COOL** and fan mode to **AUTO**. Lower the thermostat's temperature mode below room temperature and observe that the blower energizes. Check the air being discharged at the register is cooler than room temperature. Verify unit refrigerant pressures are in order.
2. Allow the unit to run for several minutes and then set the thermostat's temperature above room temperature. Verify the blower cycles off with the thermostat.

System Heating

1. Set the thermostat's system mode to **HEAT** and the fan mode to **AUTO**. Increase the thermostat's temperature above room temperature and observe that the blower energizes. Check the air being discharged at the register is warmer than room temperature.
2. Allow the unit to run for several minutes and then set the thermostat's temperature below room temperature. Verify the blower cycles off with the thermostat.

UNIT MAINTENANCE

Proper maintenance is most important to achieve the best performance from a furnace. Follow these instructions for years of safe, trouble free operation.

WARNING:

ELECTRICAL SHOCK, FIRE OR EXPLOSION HAZARD

Failure to follow safety warnings exactly could result in serious injury or property damage.

Improper servicing could result in dangerous operation, serious injury, death or property damage.

- **Before servicing, disconnect all electrical power to air handler.**
- **When servicing controls, label all wires prior to disconnecting. Reconnect wires correctly.**
- **Verify proper operation after servicing.**

- These maintenance instructions are primarily intended to assist qualified technicians experienced in the proper maintenance and operation of this appliance.
- Always reinstall the doors on the furnace after servicing or cleaning/changing the filters. Do not operate the furnace without all doors and covers in place.
- Verify that the thermostat is properly installed and is not being affected by drafts or heat from lamps or other appliances.
- To achieve the best performance and minimize equipment failure, it is recommended that a yearly maintenance checkup be performed. At a minimum, this check should include the following items:

Air Filter(s)

WARNING:

Never operate the furnace without a filter in place. Dust and lint in the return air can build up on internal components, resulting in loss of efficiency, equipment damage, and possible fire.

B6EW Air Handlers are supplied with a single air filter when shipped from the factory. It is recommended that the filter be cleaned or replaced monthly. Newly built or recently renovated homes may require more frequent changing until the construction dust has minimized. Filter sizes shown in Table 5 are available at most local retailers.

Filters designed to remove smaller particles such as pollen, may require additional maintenance.

Blower Compartment

Model Number	Filter Size
B6EW-X18K	16" x 20 x 1"
B6EW-X24K	
B6EW-X25K	20" x 20 x 1"
B6EW-X30K	20" x 20 x 1"
B6EW-X36K	24" x 20 x 1"

Table 5. Filter Sizes

Dirt and lint can create excessive loads on the motor resulting in higher than normal operating temperatures and shortened service life. It is recommended that the blower compartment be cleaned of dirt or lint that may have accumulated in the compartment or on the blower and motor as part of the annual inspection.

Blower Fan Wheel

Inspect the blower wheel blades for accumulations of dirt and clean if necessary. Inspect mounting nut for tightness when done.

Blower Motor & Assembly

Inspect the blower assembly and motor mounting brackets for tightness and corrosion. Correct deficiencies if necessary. The blower motor contains sealed bearings and under normal operating conditions, no maintenance is necessary for the life of the equipment.

TROUBLESHOOTING

If the air handler fails to operate, check the following:

- Is the electric turned on?
- Is the thermostat operating properly?
- Are the blower compartment door(s) in place?
- Is the furnace disconnect closed?
- Has the circuit breaker tripped or the control board fuse burned open?
- Are any manual reset switches open?
- Is the filter dirty or plugged?
- Is the LED on the furnace control board constantly ON? If not, refer to Table 6 to determine fault condition.

Red LED (AN2)	Diagnostic Description
OFF	Control Fault (No Power)
Flash	Blower Fault
ON	Normal Operation

Table 6. Furnace Control Board Fault Conditions

FIGURES & TABLES

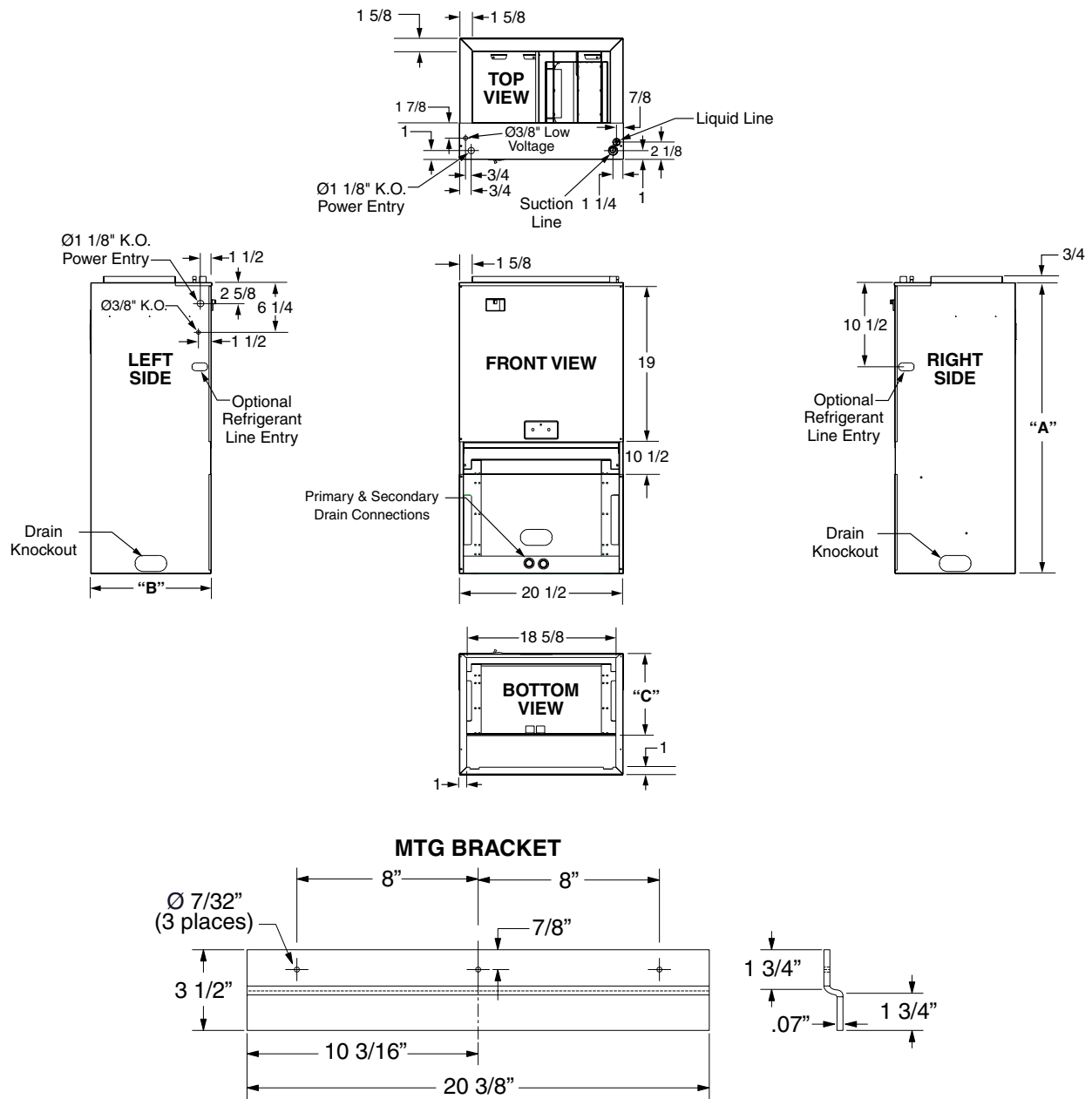

Figure 4. B6EW Physical Dimensions

MODEL B6EW-	REFRIGERANT CONNECTIONS		SUPPLY AIR DUCT DIMENSION	A	B
	SUCTION DIA.	LIQUID DIA.			
X18K	3/4	3/8	9 x 17 1/4	36 3/8	9 1/2
X24K	3/4	3/8	9 x 17 1/4	36 3/8	9 1/2
X25K	3/4	3/8	9 x 17 1/4	43 1/2	9 1/2
X30K	3/4	3/8	9 x 17 1/4	43 1/2	9 1/2
X36K	3/4	3/8	15 x 17 1/4	43 1/2	15 1/2

Table 7. B6EW Specifications

AIRFLOW DATA

X18K/X24K	Dry Coil ESP	0.1	0.2	0.3	0.4	0.5	0.6	0.7	0.8
	M1	712	678	644	604	558	514	475	436
	M2	896	859	831	805	764	731	697	657
	M3	980	927	915	885	843	813	768	730
	M4	1080	1040	1026	993	976	942	915	878
	M5	1165	1128	1118	1065	1048	1020	995	964

X25K/X30K	Dry Coil ESP	0.1	0.2	0.3	0.4	0.5	0.6	0.7	0.8
	M1	773	728	698	653	608	571	518	484
	M2	943	917	901	861	824	783	743	701
	M3	1034	993	959	942	913	869	836	795
	M4	1163	1128	1099	1067	1054	1019	967	942
	M5	1245	1215	1191	1155	1124	1102	1068	1047

X36K	Dry Coil ESP	0.1	0.2	0.3	0.4	0.5	0.6	0.7	0.8
	M1	805	758	706	645	580	518	461	412
	M2	1026	983	934	889	839	792	732	667
	M3	1121	1080	1039	1001	947	902	846	791
	M4	1275	1235	1193	1152	1112	1070	1024	971
	M5	1388	1349	1302	1261	1226	1185	1141	1092

NOTES:

- 1) Airflow is shown in cfm, +/- 5%.
- 2) External static pressure is shown in inches W.C.
- 3) All airflows are measured without filter and with dry coil. For filter, subtract .08" external static pressure. For wet coil, subtract .1" external static pressure.
- 4) See unit nameplate or installation instructions for maximum recommended external static pressure.

Table 8. Blower Performance Data

WIRING DIAGRAMS

WIRING DIAGRAM

Wall Mount Air Handler ECM (5KW)

NOTES:

1. The blower motor speed tap connection may not be as shown. Refer to installation instructions provided with unit to set DIP switches for the appropriate heating and cooling speed setting for your application.
2. Disconnect all power before servicing.
3. The transformer may have a dual voltage primary tap. Match the tap position with the supply voltage used.
4. If the internal wiring is replaced, use only 105°C copper wire of the same gauge.

Remarques

1. Le connecteur de vitesse du moteur du ventilateur peut différer de l'illustration. Consultez les instructions d'installation.
2. Débranchez toutes les sources d'alimentation avant l'entretien.
3. Le transformateur peut avoir un robinet principal à double tension. Agencez la position du robinet au type de tension de l'installation.
4. Si le câblage interne est remplacé, utilisez seulement un fil de cuivre 105° C du même gabarit.

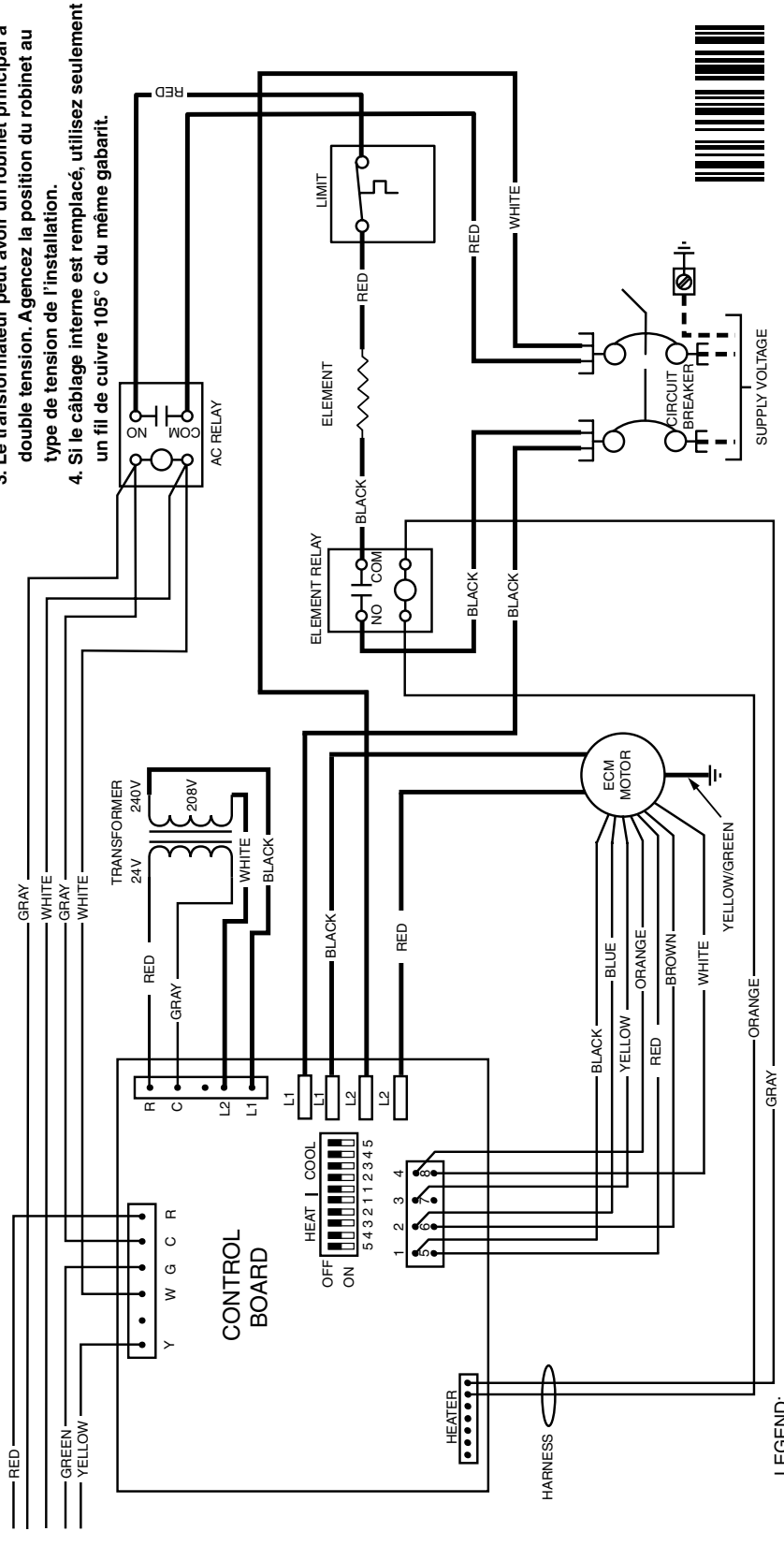

711465A
(Replaces 7114650)
09/15

Figure 5. Wiring Diagram for B6EW-X18K, B6EW-X24K, B6EW-X25K, B6EW-X30K, & B6EW-X36K (1.5, 2, 2.5, & 3 Ton Units)

WIRING DIAGRAM

Wall Mount Air Handler ECM (8KW/10KW)

NOTES:

1. The blower motor speed tap connection may not be as shown. Refer to installation instructions provided with unit to set DIP switches for the appropriate heating and cooling speed setting for your application.
2. Disconnect all power before servicing.
3. The transformer may have a dual voltage primary tap. Match the tap position with the supply voltage used.
4. If the internal wiring is replaced, use only 105°C copper wire of the same gauge.

Remarques

1. Le connecteur de vitesse du moteur du ventilateur peut différer de l'illustration. Consultez les Instructions d'installation.
2. Débranchez toutes les sources d'alimentation avant l'entretien.
3. Le transformateur peut avoir un robinet principal à double tension. Agencez la position du robinet au type de tension de l'installation.
4. Si le câblage interne est remplacé, utilisez seulement un fil de cuivre 105°C du même gabarit.

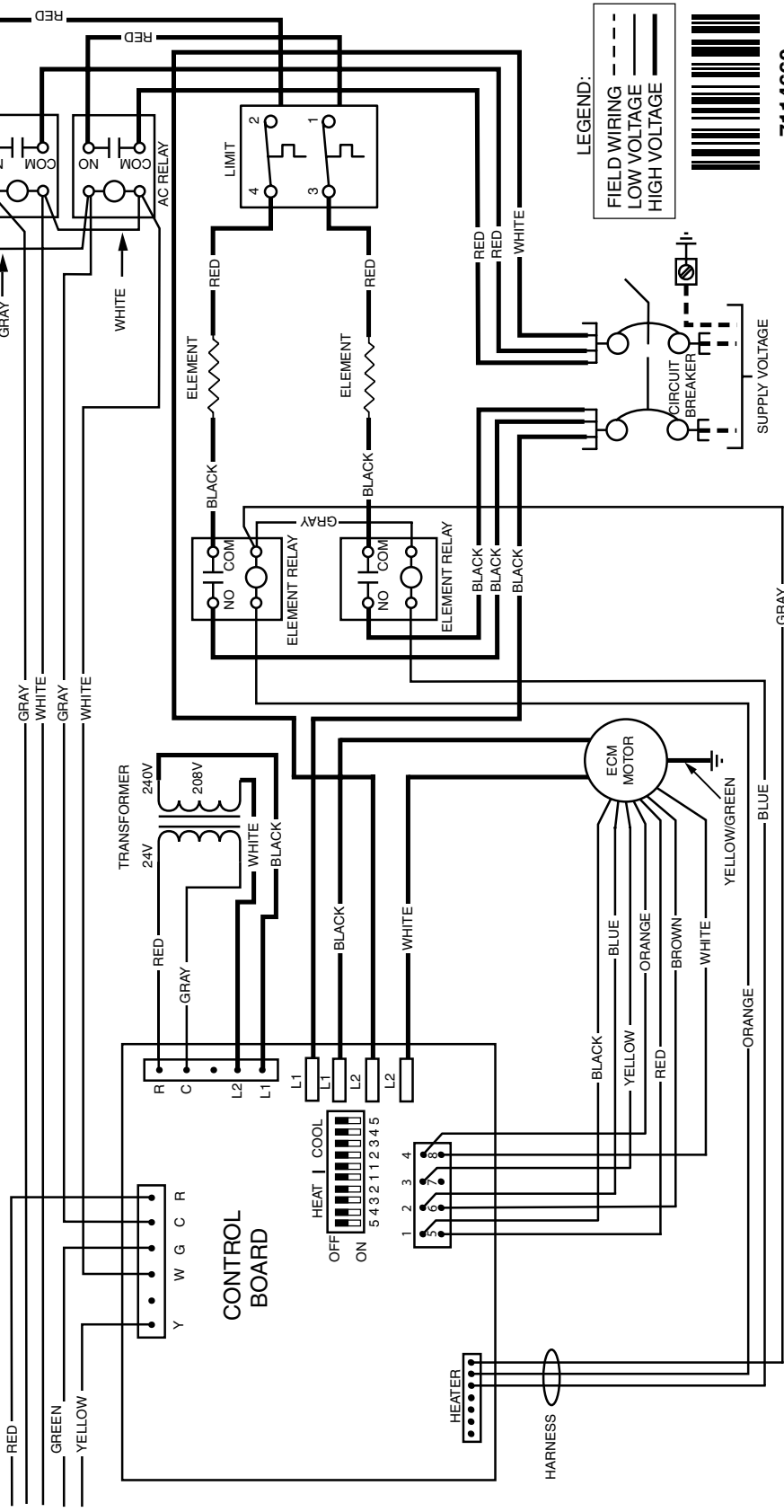

Figure 6. Wiring Diagram for B6EW-X18K, B6EW-X24K, B6EW-X25K, B6EW-X30K, & B6EW-X36K (1.5, 2, 2.5, & 3 Ton Units)

LOCATION OF AIR HANDLER COMPONENTS

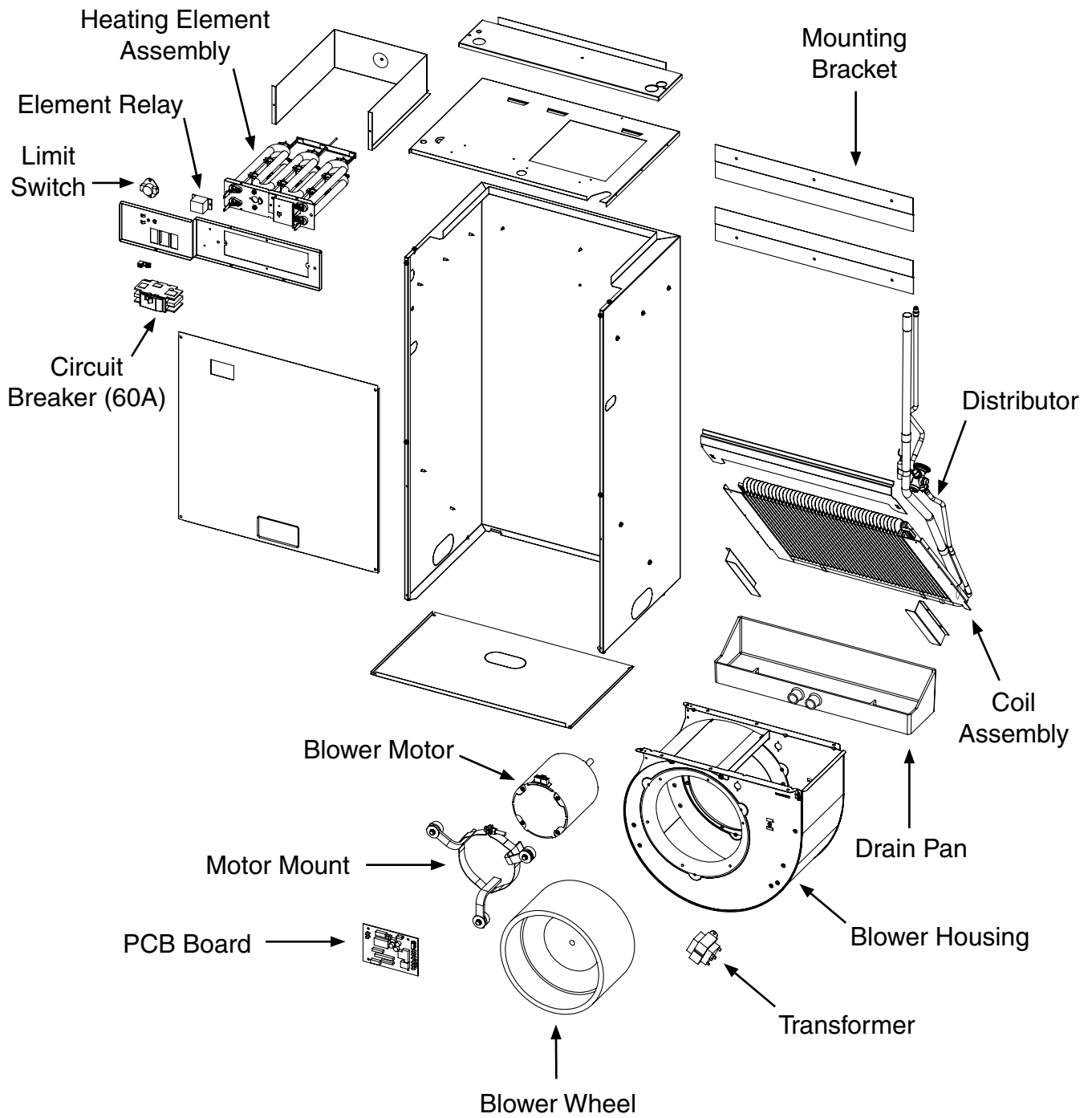

Figure 7. Air Handler Components

INSTALLATION CHECKLIST

INSTALLER NAME:		
CITY:	STATE:	
INSTALLATION ADDRESS:		
CITY:	STATE:	
UNIT MODEL #		
UNIT SERIAL #		
Minimum clearances per Table 1 (page 4)?	YES	NO
Is the unit properly installed and leveled?	YES	NO
Does condensate drain properly in both drain tubes?	YES	NO
Has the owner's information been reviewed with the home-owner?	YES	NO
Has the literature package been left near the appliance?	YES	NO

ELECTRICAL SYSTEM:		
Electrical connections tight?	YES	NO
Line voltage polarity correct?	YES	NO
Supply Voltage: _____(V)		
Has the thermostat been calibrated?	YES	NO
Is the thermostat level?	YES	NO
Is the heat anticipator setting correct?	YES	NO



ATTENTION INSTALLERS:

It is your responsibility to know this product better than your customer. This includes being able to install the product according to strict safety guidelines and instructing the customer on how to operate and maintain the equipment for the life of the product. Safety should always be the deciding factor when installing this product and using common sense plays an important role as well. Pay attention to all safety warnings and any other special notes highlighted in the manual. Improper installation of the furnace or failure to follow safety warnings could result in serious injury, death, or property damage.

These instructions are primarily intended to assist qualified individuals experienced in the proper installation of this appliance. Some local codes require licensed installation/service personnel for this type of equipment. Please read all instructions carefully before starting the installation. Return these instructions to the customer's package for future reference.

