INSTALLATION & OPERATIONS MANUAL FOR ICE CREAM HARDENING CABINETS



Models: NXBF27MMS/4 and NXBF48MMS/4

TABLE OF CONTENTS	
INTRODUCTION	3
STORE CONDITIONS	3
WARNING LABELS AND SAFETY INSTRUCTIONS	4
PRE-INSTALLATION INSTRUCTIONS	5
Inspection for Shipping Damage	5
INSTALLATION INSTRUCTIONS	5
General Instructions	5
Mechanical	5-6
Electrical	6
Low Temperature Freezers	6
Leg and Condensate Pan Installation	6
SERVICE INSTRUCTIONS	6-7
TEMPERATURE SENSOR, DEFROST HEATER AND FAN MOTOR REPLACEMENT	7
DIXELL (XR60C) ELECTRONIC REFRIGERATION CONTROL	8-9
FINAL CHECK LIST	10
SENSOR PROBE	10
SENSOR TEMPERATURE AND RESISTANCE	10
CABINET & COMPONENT AMP DRAW	11
ACCESSORIES	11
PART LIST	12
SALE AND DISPOSAL	12
WIRING DIAGRAMS	13

INTRODUCTION

This manual contains important instructions for installing, using, and servicing a Ice Cream Hardening cabinets case. A parts list is included with this manual. Read all these documents carefully before installing or servicing your equipment.

STORE CONDITIONS

The Ice Cream Hardening cabinet cases are designed to operate in the controlled environment of an air-conditioned store. The store temperature should be at or below 75°F and a relative humidity of 55% or less. At higher temperature or humidity conditions, the performance of these cases may be affected and the capacity diminished.

The Ice Cream Hardening cabinets should not be positioned where it is directly exposed to rays of sun or near a direct source of radiant heat or airflow. This will adversely affect the case and will result in poor performance.

If this case is to be located against a wall, there should be at least 4" space between the wall and the back of the case. This space will allow for the circulation of air behind the case, which will prevent condensation on the exterior surfaces.



NOTICE

Read this manual before installing your cabinet. Keep the manual and refer to it before doing any service on the equipment. Failure to do so could result in personal injury or damage to the cabinet.



DANGER

Improper or faulty hook-up of electrical components on the refrigeration units can result in severe injury or death.

All electrical wiring hook-ups must be done in accordance with all applicable local, regional or national standards.



NOTICE

Installation and service of the refrigeration and electrical components of the cabinet must be performed by a refrigeration mechanic and/or a licensed electrician.

The portions of this manual covering refrigeration and electrical components contain technical instructions intended only for persons qualified to perform refrigeration and electrical work.

This manual cannot cover every installation, use or service situation. If you need additional information have the serial number at hand and call Customer Service Department.

WARNING LABELS AND SAFETY INSTRUCTIONS



This symbol is the safety-alert symbol. When you see this symbol on your cabinet or in this manual, be alert to the potential for personal injury or damage to your equipment.

Be sure you understand all safety messages and always follow recommended precautions and safe operating practices.



NOTICE TO EMPLOYERS

You must make sure that everyone who installs, uses or services your cabinet is thoroughly familiar with all safety information and procedures.

Important safety information is presented in this section and throughout the manual. The following signal words are used in the warnings and safety messages:

DANGER: Severe injury or death will occur if you ignore the message.

WARNING: Severe injury or death can occur if you ignore the message.

CAUTION: Minor injury or damage to your cabinet can occur if you ignore the message.

NOTICE: This is important installation, operation or service information. If you ignore the message, you may damage your cabinet.

The warning and safety labels shown throughout this manual are placed on your Ice Cream Dipping case at the factory. Follow all warning label instructions. If any warning or safety labels become lost or damaged, call your customer service department for replacements

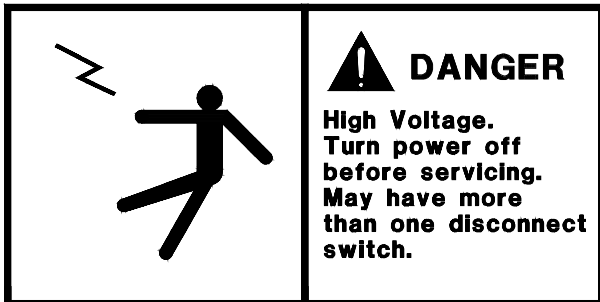

This label is attached to the cabinet power cord label and on the wiring channel.

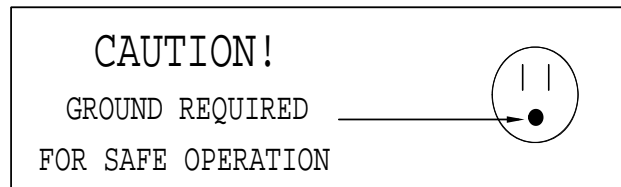

This label is located on top of the electrical control on models with a power cord.

PRE-INSTALLATION INSTRUCTIONS

INSPECTION FOR SHIPPING DAMAGE

You are responsible for filing all freight claims with the delivering truck line. Inspect all cartons and crates for damage as soon as they arrive. If damage is noted to shipping crates or cartons or if a shortage is found, note this on the bill of lading (all copies) prior to signing.

If damage is discovered when the cabinet is uncrated, immediately call the delivering truck line and follow up the call with a written report indicating concealed damage to your shipment. Ask for an immediate inspection of your concealed damage item. Crating material must be retained to show the inspector from the truck line.

INSTALLATION INSTRUCTIONS

GENERAL INSTRUCTIONS

Be sure the equipment is properly installed by competent service people.

Keep the equipment clean and sanitary so it will meet your local sanitation codes. Clean the cabinet with a mild detergent and water, then rinse.

Rotate your stock so that older stock does not accumulate. This is especially important for ice cream. A "First-In, First-Out" rotation practice will keep the products in good salable condition.

Do not place product in the case when it is soft or partially thawed. Also, product should not be put in the case for at least 6 hours after it is started.

Stock cases as quickly as possible, exposing only small quantities to store temperatures for short periods of time.

NOTICE TO STORE OWNERS / MANAGERS

Moisture or liquid around or under the cabinet is a potential slip/fall hazard for persons walking by or working in the general area of the cabinet. Any cabinet malfunction or housekeeping problem that creates a slip/fall hazard around or under the cabinet should be corrected immediately.

If moisture or liquid is observed around or under a Ice Cream Hardening Cabinet, an immediate investigation should be made by qualified personnel to determine the source of the moisture or liquid. The investigation should determine if the cabinet is malfunctioning or if there is a drainpipe leaking.

MECHANICAL

Remove front grille and check refrigeration lines to see that they are free (not touching each other or compressor). Spin condenser fan blade to see that it is free.

Check that all service valves (3) are open. Remove wooden shipping blocks under compressor. Check all refrigeration lines and electrical conduit for rubbing or chaffing, paying particular attention to area where lines enter the cabinet. Make sure the compressor switch is on before start up the cabinet.

After removing the wooden blocks, the compressor would move freely on its mounting springs.

Remove cabinet from crate base and slide into location. Cabinet must be level from side to side and front to back for correct draining of coil pan and for self-closing doors to operate correctly. Allow minimum of 4" between back of cabinet and wall and between top of cabinet and ceiling for proper condensing unit air circulation.



To comply with Sanitation requirements the cabinet must be mounted on legs (6" high min.) or casters or the base must be sealed to the floor with an N.S.F. listed silicone sealant.

To comply with UL requirements the cabinet must have a minimum clearance of 4" at the top, 6" at the rear and 0" at each side.



ELECTRICAL WARNING

Before servicing electrical components in the case or the doors or door frames make sure all power to case is off. Always use a qualified technician.

Check voltage and amps drawn on (Page 11) to determine proper line and fuse or circuit breaker size. Check power supply for low voltage. If voltage reads "230" with no load, and it drops below "207" when the compressor tries to start, it is an indication of too small supply wiring or too long to run.

It is recommended that a separate circuit be run for each cabinet to prevent another appliance blowing the fuse or breaker, causing loss of product.

****The cabinet should be grounded.****

LOW TEMPERATURE FREEZERS – "Ice cream Hardening Cabinet" Models

The Ice Cream Hardening Cabinets has a power cord (15A, 230 Volt) on top of the cabinet at the right rear for connection to power. On initial start-up the evaporator fan motors will not start and you cannot initiate a defrost until the evaporator coil temperature has lowered to 25°F. This is due to the Electronic control. Also, the cabinet comes with a non-adjustable "Front" control to keep the mullion heaters off until the cabinet temperature has lowered to 10°F.

LEG AND CONDENSATE PAN INSTALLATION FOR TOP MOUNT CABINETS ONLY

1. Screw legs into existing crate mounting holes.
2. Mount pan and bracket assembly to rear of cabinet with 2 large sheet metal screws (supplied). Be sure pan is located directly under cabinet drain.

SERVICE INSTRUCTIONS

1. High head pressure and high back pressure:
 - A. Condenser coil clogged or restricted
 - B. Condenser fan motor defective.
 - C. Air discharge in rear of cabinet restricted.
2. Low back pressure and low head pressure:
 - A. Restriction in system.
 - B. Refrigerant undercharged.
 - C. Leak in system
3. Pressure normal – cabinet warm:
 - A. Coil blocked with frost (see #4).
 - B. Refrigerant undercharged.
 - C. Control set too warm.
4. Cabinet not cycling – coil blocked with frost:
 - A. Defective temperature controller.
 - B. Refrigerant overcharged.
 - C. Location too hot.
 - D. Condenser clogged.
 - E. Condenser fan motor defective.
 - F. Defrost heater not operating.

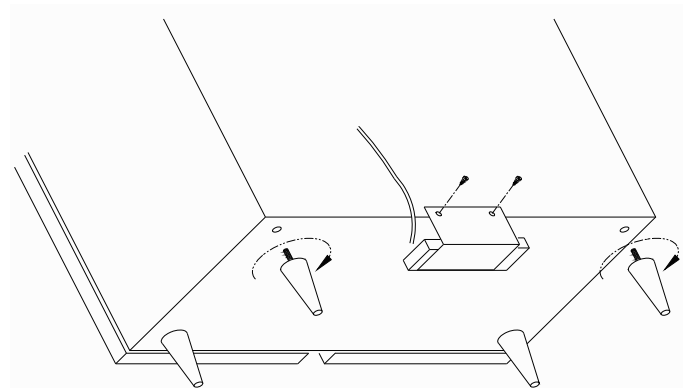

5. Compressor starts and runs – but cycles on overload:
- A. Low voltage
 - B. Relay defective.
 - C. Overload defective.
 - D. High head pressure (see #1).

TEMPERATURE SENSOR, DEFROST HEATER AND FAN MOTOR REPLACEMENT

Before making any change, technician should:

1. Disconnect power to the cabinet
2. Remove screws from venturi and pull down

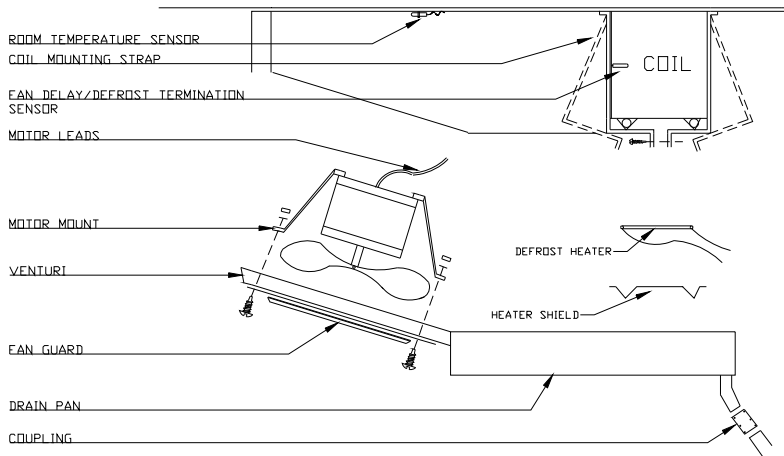

Sensor

To change a temperature sensor (cabinet zone sensor or defrost termination sensor), simply disconnect the sensor wires from the controller and replace the new sensor in the original position. Use plastic tie to tighten the zone sensor. Insert the sensor for defrost termination firmly into the evaporator coil, in between the fins. Make sure the sensor wires do not touch or are not close to any heater rods.

Defrost Heater

To change defrost heater – remove screws from drain pan and pull down – remove screws from coil mounting straps – spring straps open – remove heater shield – pull heater out of slots in coil fins.

Fan Motor

To change fan motor – disconnect fan motor leads – remove screws from fan guards and motor mounts.

ELECTRONIC REFRIGERATION CONTROL

OPERATION

Compressor: When power is first turned on to the control, the LED snowflake indicator on the display starts blinking. After one-minute delay the compressor comes on. The LED snowflake indicator stays on while compressor relay is energized. Display will show actual box temperature. Figure 4 is the display layout.

The compressor will be cycled off when the actual box temperature reaches its set point. The LED snowflake indicator will be off.





Fig. 4 – Display Lay-out

Fan: The fans will run constantly except when a defrost is initiated, or when the evaporator temp is above the 25°F. When in defrost mode the fan is off until the end of the defrost and the 2 minute drip time has passed. There is 2 minutes delay after a defrost before the fan comes on. If the Evaporator Temperature is 0°F or below the controller will override the fan delay. FAN LED indicator is on while FAN relay is energized.

Defrost: The control uses time defrost with 3 defrost per day. A programmed “HOT-KEY” has to be used to re-set the defrost scheme for special applications. During defrost the display will show dEF and the LED indicator under DEF in on. The control begins timing the defrost when power is turned on. Three defrost per day means it will occur every 8 hours. To have defrost occur at 8am, 4pm, and 12pm then power up at lone of these three times.

MANUAL DEFROST

1. Push this **DEFROST**  key for more than 2 seconds and a manual defrost will start.
2. While in defrost, Push and hold the **DEFROST**  key for more than 5 seconds and the controller will end the defrost cycle. The controller will then enter drip mode for 2 minutes. The dF led is flashing in drip mode.

HOW TO SEE THE SETPOINT (Box temperature cut-out)

1.  Push and immediately release the **SET** key: the display will show the Set point value;
2. Push and immediately release the **SET** key or wait for 5 seconds to display the probe value (actual box temperature) again.

HOW TO CHANGE THE SETPOINT

1. Push the **SET** key for more than 2 seconds to change the Set point value;
2. The value of the set point will be displayed and the LED under COMP starts blinking;
3. To change the Set value push the **UP ▲** or **DOWN ▼** arrows within 10s.
4. To memorize the new set point value push the **SET** key again or wait 10s.

HOW TO CHANGE A PARAMETER VALUE



1. Enter the Programming mode by pressing the **SET** and **DOWN ▼** keys for 3 seconds (LEDs under dF and COMP start blinking).
2. Select the required parameter by pushing the **UP ▲** or **DOWN ▼** arrows
3. Press the “**SET**” key to display its value (now only the COMP LED is blinking)
4. Use “**UP**” or “**DOWN**” to change its value
5. To exit: Press **SET + UP ▲** or wait 15s without pressing a key.

NOTE 1: The set value is stored even when the procedure is exited by waiting the time-out to expire.

NOTE 2: Manufacture SETPOINT is set at a recommended -40°F at the factory.

NOTE 3: To scroll down the parameters without changing them, press the DOWN button.

LIST OF PARAMETERS

Here is a list of the parameters the value of which can be changed in the programming mode, as well as their ranges.

Display Symbol	Description	Range	Factory Setting
St	Temperature set point	-55 to 15°F	-30° F
Hy	Cut-out temperature is Set + Hy, Differential	1 to 255°F	7° F
AU	High temperature alarm is enabled after a delay	230°F	15° F
AL	Low temperature alarm is enabled after a delay	-58°F	-45° F
Ad	Alarm delay	0 to 255 min	30

ALARM SIGNALS

Message	Cause	Outputs
“ P1 ”	Room probe failure	Compressor output according to par. “Con” and “COF”
“ P2 ”	Evaporator probe failure	Defrost end is timed
“ HA ”	Maximum temperature alarm	Outputs unchanged.
“ LA ”	Minimum temperature alarm	Outputs unchanged.
“ dA ”	Door open	Compressor and fans restarts
“ EA ”	External Alarm	Output unchanged
“ CA ”	Serious External alarm (i1F=bAL)	All output off
“ CA ”	Pressure switch alarm (i1F=PAL)	Outputs unchanged.

NOTE:

Probe alarms “**P1**” and “**P2**” start some seconds after the fault in the related probe; they automatically stop some seconds after the probe restarts normal operation. Check connections before replacing the probe. Temperature alarms “**HA**” and “**LA**” automatically stop as soon as the thermostat temperature returns to normal values and when defrost starts.

FINAL CHECK LIST

- A. Check operating pressures.
- B. Check electrical requirements of unit to supply voltage.
- C. Set temperature control for desired temperature setting.
- D. Check sight glass (if applicable) for proper refrigerant charge.
- E. Check to make sure the compressor switch, behind the front grill, is on before start up the cabinet.
- F. Check condensing unit for vibrating or rubbing tubing. Dampen and clamp as required.
- G. All valves should be completely opened counter-clockwise.
- H. Check packing nuts on all service valves.
- I. Replace all service valve caps and latch unit covers.

SENSOR PROBE

NOTICE: If the probe assembly is disconnected from the main board during normal operation (unit running), the connectors must be installed in the same position that they had before disconnection (P1 and P2), otherwise the control will not function properly.

The Electronic Refrigeration Control sensors have NTC thermistors. The reference resistance is 10,000 ohms at 77°F (25°C). It carries NTC thermistors with a range of -58° to 230° F. In case there is a failure, these sensors should be used in replacement of the sensors shipped with the control. In order to diagnose faults in the probe, the control has LED functions as a diagnostic tool. When power is supplied to the control, the control display will flash P1 for a roomprobe failure and P2 for an evaporature probe failure

In case of a probe failure, the control will go into a safety mode of operation. While in safety mode the control ignores probe inputs and cycles the compressor on for 6 minutes and off for 4 minutes. To replace the sensor probes, disconnect power to the control, replace the probes and restart the unit. Since the wire is fixed to the cabinet, a technician may cut the sensor wire inside the cabinet and splice it with a new sensor.

SENSOR PROBE TEMPERATURE AND RESISTANCE

Temperature		Resistance
°F	°C	Ohms
-31	-35	144,100
-22	-30	111,300
-12.5	-25	861,430
-4	-20	67,770
5	-15	53,410
14	-10	42,470
23	-5	33,900
32	0	27,280
41	5	22,050
50	10	17,960
59	15	14,690
68	20	12,090
77	25	10,000
86	30	8,313

CABINET COMPONENT AMP DRAW

(Condition: -30°F box and 80°F ambient temperature)

NXBF48MMS/4		VOLTAGE		AMPS @	AMPS @	NOTES
ITEM	PART NO.	RATING	208 VOLTS	230 VOLTS	230 VOLTS	
Coil Defrost Heater	149382	230 V	4.5	5		Check Yellow wire from controller
Drain Pan Heater	149412	230 V	1.4	1.5		Check Yellow wire from controller
Condensate Heater	149388	230 V	1.2	1.3		Check Either Red or Black leg
Door Frame Heater	149401	220 V	.52 ea	0.52 ea.		Check black/white wire
Drain Heater	149410	230 V	0.03	0.03		Check either leg
Condenser motor	149394	230 V	0.4 ea.	0.4 ea.		Check either leg
Evaporator motor	149420	230 V	0.2 ea.	0.2 ea.		Check Orange wire from controller
Compressor	149386	230 V	6.4	6.8		Check either leg
NXBF27MMS/4		VOLTAGE		AMPS @	AMPS @	NOTES
ITEM	PART NO.	RATING	208 VOLTS	230 VOLTS	230 VOLTS	
Coil Defrost Heater	149383	230 V	2.7	3		Check Yellow wire from controller
Condensate Heater	149387	230 V	1.2	1.3		Check Either Red or Black leg
Door Frame Heater	149401	220 V	0.54	0.54		Check black/white wire
Drain Heater	149410	230 V	0.03	0.03		Check either leg
Condenser motor	149394	230 V	0.4	0.4		Check either leg
Evaporator motor	149419	230 V	0.2	0.2		Check Orange wire from controller
Compressor	149385	230 V	4.6	4.9		Check either leg

Accessories

Description	NXBF27MMS/4	NXBF48MMS/4
Casters (4) 5" diameter	A297-11140	A297-11140
Tray Slides		
9/16" lip ledge for 12" X 20" or 18" X 26" pans (must specify)	A340-21100	
1-3/16" bottom ledge for 12" X 20" or 18" X 26" pans (must specify)		A340-21200
Voltage Boosting Transformer	39-01080	39-01080

PART LIST

Use this chart when ordering replacement parts for your **Ice Cream Hardening Cabinets**. Always Advise Cabinet Serial Number When Ordering Parts.

Description	NXBF27MMS/4	NXBF48MMS/4
Cabinet Frame Heater	149381	149382
Coil Defrost Heater	149383	149384
Compressor	149385	149386
Condensate Heater	149387	149388
Condenser Coil	149389	149390
Condenser Fan Blade	149391	149391
Condenser Fan Guard	149392	149393
Condenser Fan Motor	149394	149394
Controller	149395	149395
10' Sensor assy (2)	149396	143996
Contactora	149397	149397
Door Handle	149398	149398
CRO Valve	149399 12.5p set	149400 22 # Setting
Door Frame Heater	149401	149401
Door Gasket	149402	149403
Door Hinge-Inner Doors-L.H.		149405
Door Hinge-Inner Doors-R.H.	149406	149406
Door Hinge-Outer Doors	149407	149407
Door Trim	149408	149409
Drain Line Heater	149410	149410
Drain Pan Heater		149412
Evaporator Coil	149413	149414
Evaporator Fan Blade	149415	149416
Evaporator Fan Guard	149417	149418
Evaporator Fan Motor	149419	149420
Expansion Valve	149421	149421
Female Plug	149422	
Front Control	149424	149424
Heater Safety Control	149425	149425
Leg	149426	149426
Compressor Switch	149427	149428
Shelves (Cantilever)	149429	149430
Sight Glass		
Vibration Eliminator (1/2")	--	
Vibration Eliminator (5/8")	--	

SALE AND DISPOSAL

OWNER RESPONSIBILITY

If you sell or give away your cabinet, you must make sure that all safety labels and the Installation Service Manual are included with it. If you need replacement labels or manuals, contact the customer service department and we will provided them free.

The customer service department should be contacted at the time of sale or disposal of your cabinet so records may be kept of its new location.

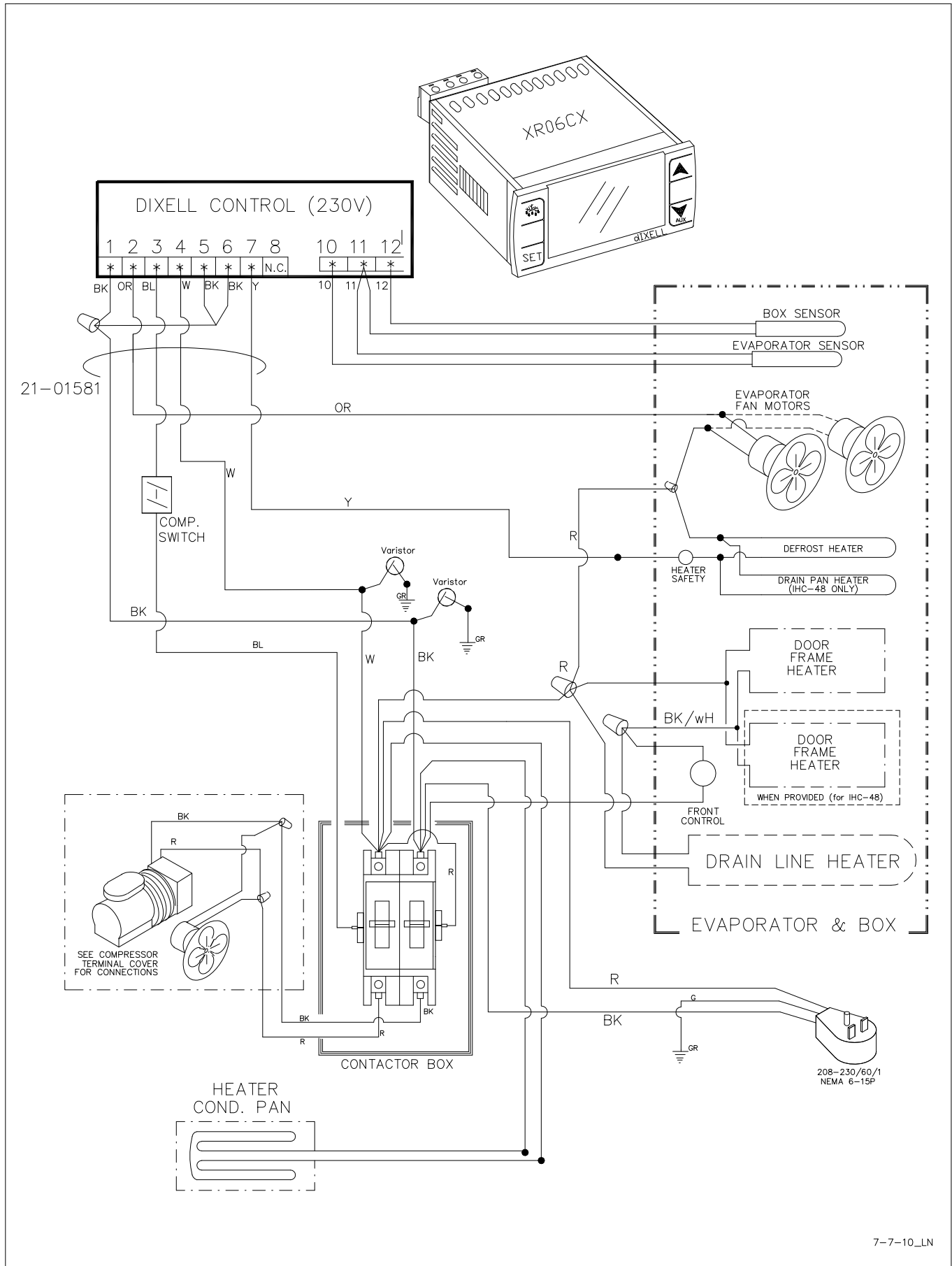

7-7-10_LN