



FOOD EQUIPMENT

Operating and Maintenance Instructions

56450A-2R

FryKutter, 3/8" Cut

IMPORTANT

CLEAN MACHINE THOROUGHLY BEFORE USING IT FOR THE FIRST TIME!

1. To get the best operation and life from your machine, please read and comply with these instructions.
2. Clean machine thoroughly after each use using cleaning instructions below.
3. Minimize the use of alkaline cleaners as they may cause pitting and dulling of the finish.

SAFETY INSTRUCTIONS

Remember that the blades are **VERY SHARP!** Be careful when handling and operating the machine to keep hands away from the **BLADES**.

PREPARATION

1. The FryKutter is to be mounted in a horizontal fashion and attached to a solid sturdy sink or prep table.
2. If unit fails to operate properly when first used call NEMCO customer service at 1-800-782-6761.

OPERATION OF FryKutter

1. With the LEVER in the fully opened position, lay the prepared produce in the trough.
2. Remove hands and fingers from the cutting area.
3. With one quick motion pull on LEVER to cut produce. Occasionally if the produce is very large, or if it is positioned at an angle to the blades, this may have to be repeated to cut it entirely through.
CAUTION: Do not attempt to chop produce larger than the opening in the BLADE HOLDER.
4. Clean the machine after cutting is completed, using cleaning instructions below.

TO CLEAN THE FryKutter

1. *Always thoroughly wash the PUSH BLOCK and the BLADE AND HOLDER ASSEMBLY.*
2. Release PUSH BLOCK by turning the THUMB SCREWS located on the PUSH BLOCK GUIDE in a counter clockwise motion until the PUSH BLOCK is loose.
3. To reassemble the PUSH BLOCK hold it up against the PUSH BLOCK GUIDE and fasten it by turning the THUMB SCREWS.
4. To remove the blade assembly, unscrew the GUIDE RODS to release the BLADE AND HOLDER ASSEMBLY and carefully remove it.
5. To reattach the BLADE AND HOLDER ASSEMBLY, hold the BLADE AND HOLDER ASSEMBLY tight to the bottom of the FRAME. Completely tighten both GUIDE RODS so the BLADE AND HOLDER ASSEMBLY is held tightly against the bottom of the FRAME.

TO LUBRICATE

1. When necessary, lubricate GUIDE RODS and PINS at each joint utilizing with Mineral Oil or Food Grade Grease.
2. DO NOT LUBRICATE WITH COOKING OIL – IT GETS STICKY.

56450A-2R, SERVICE PARTS

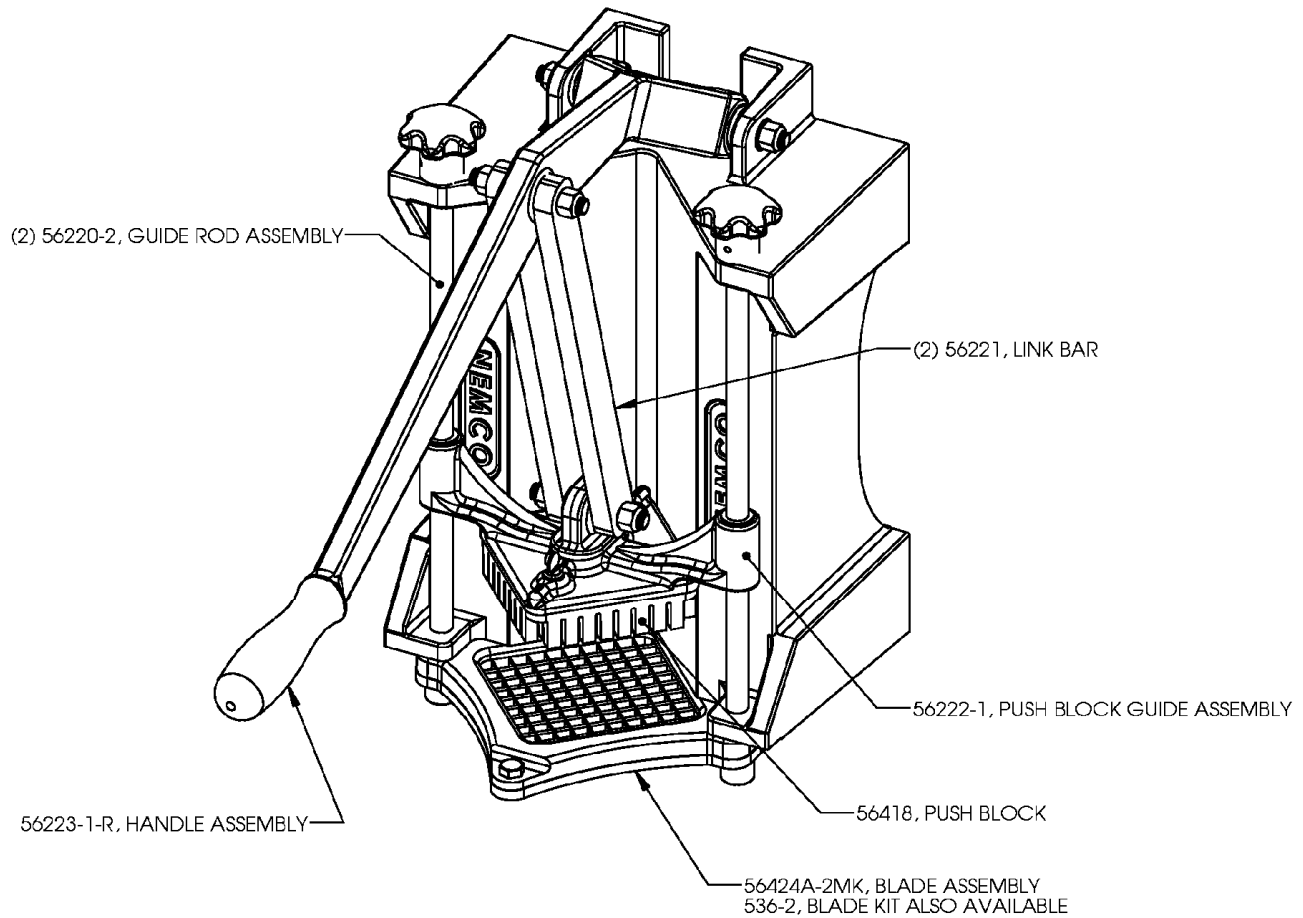

56222-1, PUSH BLOCK GUIDE ASSEMBLY - INCLUDES

- (2) 56203, BUSHINGS
- (1) 56222, PUSH BLOCK GUIDE

56223-1-R, HANDLE ASSEMBLY - INCLUDES

- (1) 56223-R, HANDLE
- (2) 56197, HANDLE PIVOT BUSHING
- (1) 56198, HANDLE LINKAGE BUSHING

56424A-2MK, BLADE ASSEMBLY - INCLUDES

- (2) 47627, SCREW
- (1) 56087-2, BLADE FRAME
- (1) 56276-1, BLADE PLATE ASSEMBLY
- (4) 56409, SPACER
- (9) 56413, TOP BLADE
- (9) 56414, BOTTOM BLADE

536-2, BLADE KIT - INCLUDES

- (9) 56413, TOP BLADE
- (9) 56414, BOTTOM BLADE