



FOOD EQUIPMENT

Operating and Maintenance Instructions

Model: 9015, Dual 1/3 Pan Condiment Chiller

INTRODUCTION

1. Please read instructions before using this appliance.
2. When using electrical appliances, basic precautions should always be followed to reduce the risk of fire, electric shock and injury.
3. Clean machine thoroughly before and after all uses following cleaning instructions below.
4. Thoroughly inspect package for damage before and during unloading. If the equipment is received damaged, either visible or concealed, a claim must be filed with the carrier.

ELECTRICAL REQUIREMENTS

Plug power supply for chiller into a grounded outlet with correct voltage and sufficient power capacity. Plug 12 volt adaptor into the power connector in the back of the unit. Refer to the product label (serial plate) on the back panel for voltage and wattage requirements.

SAFETY INSTRUCTIONS

1. **Warning!** All power must be disconnected at power source before any service procedure is performed.
2. Extreme caution is necessary when any appliance is used by or near children and whenever the appliance is left unattended.
3. Always unplug appliance when not in use and before cleaning, adjusting or maintaining this machine. To disconnect appliance, turn controls off and remove plug from power source.
4. DO NOT operate the chiller with the back panel or back cover removed.
5. DO NOT block filter/fan areas. This unit needs to have airflow in order to work properly.
6. Do not operate any appliance with a damaged cord or plug, after the appliance malfunctions, has been dropped, or damaged. Return appliance to an authorized service facility for examination, electrical or mechanical adjustment, or repair.
7. Do not use outdoors. This appliance is not intended for use in wet or moist locations. Never locate appliance where it may fall into water.
8. Connect to properly grounded outlets only. Avoid the use of extension cords. Do not run cord under carpeting, runners, or the like. Arrange cord away from traffic area and where it will not be tripped over.
9. This appliance is equipped with a power cord with a three-blade plug. Plug ONLY into a matching three-blade outlet. DO NOT cut or break off the third blade or attempt to use with a two-blade extension cord.
10. To prevent a possible fire, it is recommended that the unit is placed on a non-combustible surface.
11. This appliance has electrical parts. Do not use it in areas where gasoline, paint, or flammable liquids are used or stored.

PREPARATION

1. Set chiller on a flat stable surface, near the power source.
2. Clean the chiller thoroughly before use with a warm wet cloth to remove any shipping dust or oil residue from manufacturing process.
3. **IMPORTANT: 3/4 inch of clearance is required from back and two sides. Do not remove bumpers on side of unit.**
4. If unit fails to work properly when first operated call NEMCO customer service at 1-800-782-6761.

OPERATION

1. Plug CORD into grounded electrical outlet of the correct voltage. Electrical shock can occur if appliance is not grounded.
2. Turn on the power switch and allow unit to cool for 90 minutes. The unit has been calibrated at the factory for 36°F-40°F.
3. Place product to be chilled into inset pan and then place inset pan into chiller.
4. Avoid product in container freezing by keeping container from touching chiller wall.
- 5.

For Best results:

- Pre-chill food prior to placing into chiller
- Keep lids on when not serving

CLEANING

NOTE: Proper maintenance plays an important part in the life span and functioning of the unit. To maintain appearance and increase the service life, the unit should be cleaned at least daily.

Daily Cleaning

1. Unplug the power cord before cleaning or moving.
2. Lift out removable food containers. Clean thoroughly.
3. Wipe exterior with damp cloth. Do not use scouring powders or abrasive cleaners. Do not pour water or saturate power switch, power cord, or temperature display area. DO NOT IMMERSE IN WATER.



NEMCO FOOD EQUIPMENT 301 Meuse Argonne, Hicksville, OH 43526
Phone: (419) 542-7751 Fax: (419) 542-6690 Toll free: 1-800-782-6761
www.nemcofoodequip.com

NOTE: NEVER use vinegar or corrosive cleaners. DO NOT use chlorine based cleaners. Do not clean with steel wool or wire brushes. Use cleaners SAFE for stainless steel.

TROUBLESHOOTING

If the unit fails to operate properly, check for the following:

1. Make sure the unit is plugged in and turned on.
2. Check that the circuit breaker has not been tripped.
3. Check that the plug has the proper voltage as specified on the data plate.

Repair: To avoid serious injury or damage, do not repair the unit or replace a damaged power cord yourself. Repairs must be coordinated through NEMCO Food Equipment customer service at 1-800-782-6761.

BASIC PROGRAMMING

TO CHANGE TEMPERATURE SET POINT: Press and Hold the “SET” Button on Control until temperature starts flashing. Once flashing, use the UP or DOWN ARROW to adjust the set point.

TO CHANGE TEMPERATURE RANGE: Press and Hold the “SET” and “Down Arrow” at the same time until “HY” is displayed. Release the buttons and press the “SET” button. The pre-programmed value is 15. Use the up and down arrow to change the temperature range.

NOTE: DO NOT CHANGE ANY OTHER CONTROL SETTINGS WITHOUT CONTACTING NEMCO FOOD EQUIPMENT. SOME PROGRAM FEATURES ARE NOT COMPATIBLE WITH THIS UNIT AND WILL CAUSE UNIT TO NOT WORK PROPERLY.

EXPLODED PARTS DIAGRAM

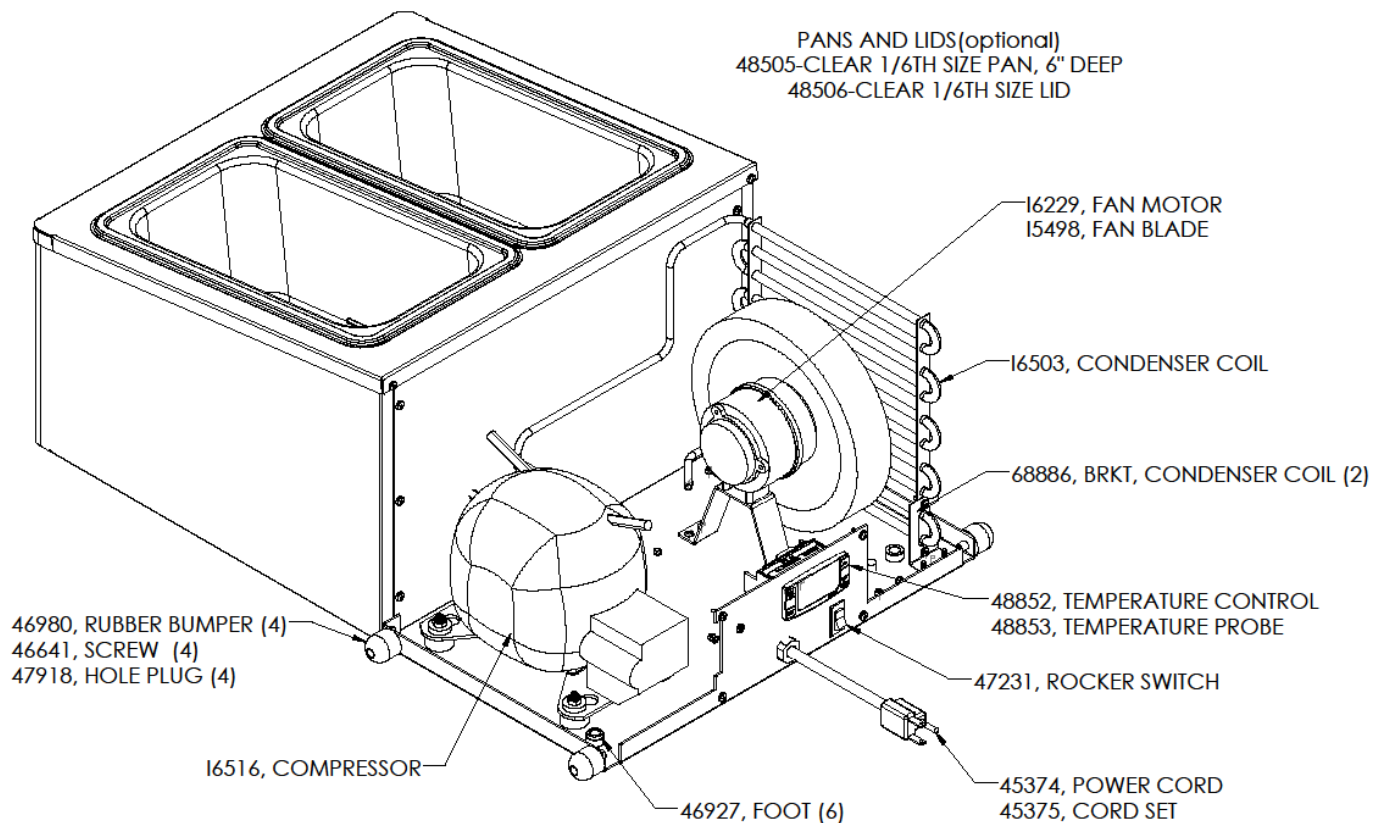

NEMCO FOOD EQUIPMENT 301 Meuse Argonne, Hicksville, OH 43526
Phone: (419) 542-7751 Fax: (419) 542-6690 Toll free: 1-800-782-6761
www.nemcofoodequip.com

