



## NEMCO Auto-Start Belgian Waffle Baker-Digital Model: 7020A-( )AS

### OPERATING INSTRUCTIONS

#### **INTRODUCTION**

1. To get the best operation and life from your machine, please read and comply with these instructions.
2. When using electrical appliances, always follow basic precautions to reduce the risk of fire, electric shock and injury to persons.
3. Clean machine thoroughly before first use and after each use using cleaning instructions below.

#### **SAFETY INSTRUCTIONS**

1. Plug electrical cord into a certified electrical outlet with a corresponding voltage rating as listed on the machine model labels.
2. Always unplug the electric cord when appliance is not in use and before cleaning, adjusting or maintaining this machine. Do not operate with a damaged cord or plug or after the machine malfunctions, has been dropped or damaged. Use authorized service for examination, electrical or mechanical adjustment or repair.
3. This machine will be HOT during use and for a short time after it is turned off – BE CAREFUL. To avoid burns, do not let bare skin touch hot surfaces. If provided, use handles when moving this appliance. Keep combustible materials away from appliance.
4. Use extreme caution when any appliance is used by or near children and whenever the appliance is left operating and unattended.
5. This appliance is not intended for use near or around water. Never locate appliance where it may fall into a water container.

#### **ELECTRICAL REQUIREMENTS**

Refer to the product tag (serial plate) on the back of the unit for electrical requirements. Be sure to plug unit into grounded outlet with sufficient power.

#### **PREPARATION AND PROGRAMMING TIME AND TEMPERATURE**

1. Set unit on a flat surface
2. Position unit near the power outlet. Avoid the use of extension cords. Do not run cord under carpeting or cover with runners or the like. Arrange cord where it will not be tripped over.
3. This appliance has hot and live electrical parts. Do not use it in areas where gasoline, paint or flammable liquids are used or stored
4. **If unit fails to work properly when first operated call NEMCO customer service at 1-800-782-6761**  
**NOTE: The unit is factory set at 385 degrees Fahrenheit for 3 minutes and 30 seconds.**
5. The following steps may be taken to alter factory pre-programmed settings.
6. A cycle may be cancelled by depressing and holding the "start/stop" button.
7. To change the pre-programmed time, press and hold the "minutes" button for roughly 10 seconds. Pressing the minutes button will increment the minutes digit and pressing the seconds button will increment the seconds digit(s).
8. When the desired changes have been completed press the "start/stop" button to store the changes. NOTE: Any and all changes will be stored, and will not be affected by power supply.
9. To change the pre-programmed temperature setting, press and hold the "start/stop" for roughly 10 seconds. NOTE: Temperature is displayed in degrees Fahrenheit. The temperature is adjusted up by pressing the minutes button and adjusted down by pressing the seconds button.
10. When the desired changes have been completed press the "start/stop" button to store the changes. NOTE: Any and all changes will be stored, and will not be affected by power supply.

#### **STARTUP AND SEASONING THE GRIDS**

1. For best results and to eliminate sticking on aluminum grids, the grids should be seasoned following the steps below. Any good nonstick agent will work. It will be necessary to re-coat from time to time.
2. Coat only new or clean grids.
3. Spray the grid surface and allow to "dry" for at least 30 minutes.
4. Turn baker on for at least 30 minutes. Baker is now ready to use

#### **OPERATION**

1. Push on-off switch to the "ON" position. Switch will be lighted when the baker is on.
2. L.E.D display will read "Lo", indicating the grids have not reached the set point temperature.
3. Time cycle will be displayed once temperature has been reached, approximately 15 minutes.
4. Open grids and pour batter on lower grid.
5. Close grids and rotate 180 degrees for proper batter distribution and to start the timing cycle. NOTE: The timing cycle can be canceled at any time by pressing and holding the "start/stop" button for roughly 3 seconds or rotating the grids back over, 180 degrees, to the starting position.
6. When the timer reaches 0:00 the alarm will sound for 10 seconds.
7. Open grids and remove waffle.

**IMPORTANT:**

1. Frequent use of vegetable oil or non-stick agents on grids will contribute to carbon build up.
2. Keep grids clean as an abundance of oil coating and carbon build up has an insulating effect and will increase preheat and cooking time.
3. When the baker is not in use, keep grids closed to prevent heat loss.

**CLEANING**

**NOTE:** Proper maintenance plays an important part in the life span and functioning of the unit

1. **CAUTION:** Unplug the power cord from electrical source before cleaning.
2. Do not immerse in water or other liquid.
3. Wipe down unit using a damp cloth or sponge and hot detergent water.
4. Rinse by wiping with a damp cloth.
5. Wipe dry.
6. Soak grids in hot soapy water. Wash with soft brush. Rinse and wipe dry. **Do not place damp grids in unit!**
7. **HEAVILY CARBONED GRIDS – may need to use a carbon build-up cleaner, such as Sok- Off. CAUTION: - USE ONLY "SAFE FOR ALUMINUM" CLEANERS OR PERMANENT DAMAGE MAY RESULT. CONSULT SPECIFIC INSTRUCTION FOR EACH CLEANER FOR PROPER USE.**
8. Grids will need to be re-seasoned.
9. Do not use wire brush or metal abrasives.
10. Be careful to not allow case to get wet, doing so will damage digital control circuit.

**NOTE: WARRANTY DOES NOT COVER DAMAGE TO THE GRID. IT IS NEMCO'S SOLE DISCRETION TO DETERMINE IF A GRID IS WARRANTED.**

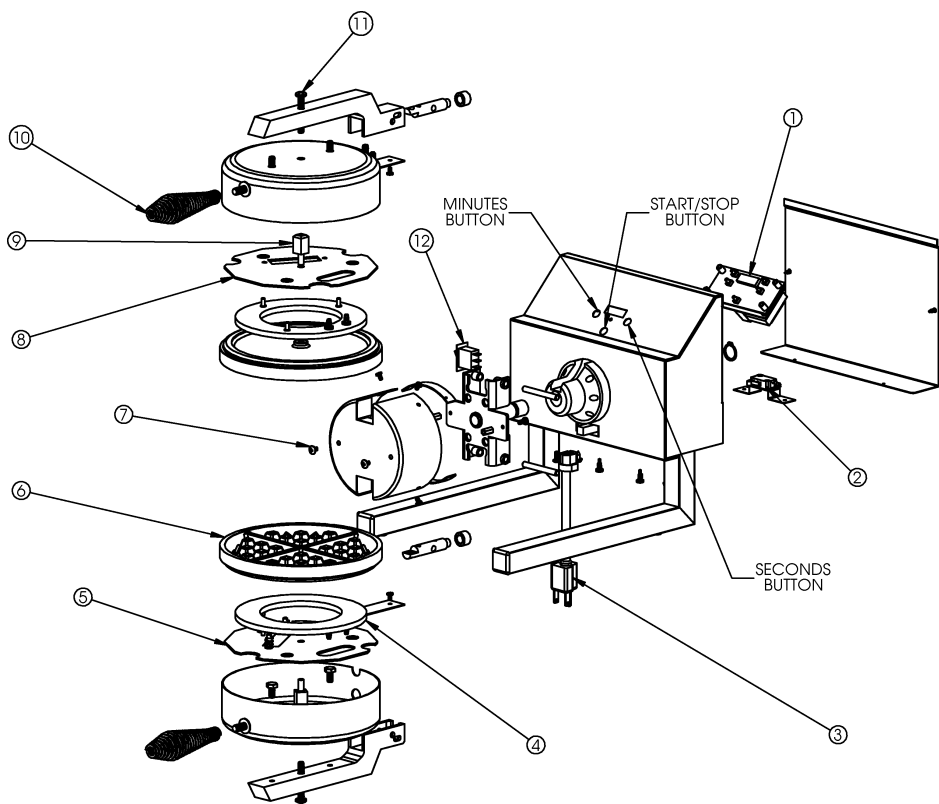

<b>SERVICE PARTS LIST</b>	
PART #	DESCRIPTION
48265-1	CONTROL BOARD
48266	MICRO SWITCH
46383	CORDSET
77036-2	ELEMENT
77342-2	BOTTOM ELEMENT PLATE
77392	GRID
47630	SCREW, #8-32 x 1/4"
77342-1	TOP ELEMENT PLATE
77217	STANDOFF
77020	HANDLE
46604	SCREW, 1/4-20 x 1-1/2"
47231	ROCKER SWITCH

**NEMCO FOOD EQUIPMENT**

301 Meuse Argonne, Hicksville, Ohio 43526

Phone: (800)-782-6761

Fax: (419)-542-6690

www.nemcofoodequip.com