

Operating and Maintenance Instructions

Model Series: 6302-() Heated Shelves

INTRODUCTION

1. Please read all instructions thoroughly before using this appliance.
2. When using electrical appliances, basic precautions should always be followed to reduce the risk of fire, electric shock and injury.
3. Clean machine thoroughly before and after all uses following the cleaning instructions below.

ELECTRICAL REQUIREMENTS

Plug warmer into a grounded outlet with correct voltage and sufficient power capacity. Refer to the product label (serial plate) on the warmer for voltage and wattage requirements.

SAFETY INSTRUCTIONS

1. **Warning!** All power must be disconnected at power source before any service procedure is performed.
2. This appliance is hot when in use. To avoid burns, do not let bare skin touch hot surfaces. Keep combustible materials away from the appliance.
3. Extreme caution is necessary when any appliance is used by or near children and whenever the appliance is left unattended.
4. Always unplug appliance when not in use and before cleaning, adjusting or maintaining this machine. To disconnect appliance, turn controls off and remove plug from power source.
5. Do not operate any appliance with a damaged or altered cord or plug, after the appliance malfunctions, has been dropped, or damaged. Return appliance to an authorized service facility for examination, electrical or mechanical adjustment, or repair.
6. Do not use outdoors. This appliance is not intended for use in wet or moist locations. Never locate appliance where it may fall into water.
7. Connect to properly grounded outlets only. Avoid the use of extension cords. Do not run cord under carpeting, runners, or the like. Arrange cord away from traffic area and where it will not create a trip hazard.
8. To reduce the risk of fire, it is recommended that the unit is placed on a non-combustible surface.
9. This appliance has electrical parts. Do not use it in areas where gasoline, paint, or flammable liquids are used or stored.

PREPARATION

1. Remove heat shelf from packaging.
2. Install the heat shelf on a flat, stable, non-combustible surface near a power source.

OPERATION

1. This product is intended to hold hot, packaged food items for up to 30 minutes.
2. Plug CORD into a grounded electrical outlet of the correct voltage. Electrical shock can occur if appliance is not grounded properly.
3. Preheat the heat shelf. Turn the unit on, and move control knob to setting 10. The heat shelf will preheat in 30 minutes.
4. **Do not put food product directly onto the heat shelf. Food must always be placed on the shelf using an appropriate container or tray.**
5. For the function of hot food holding, set the heat control knob to the desired setting. Monitor food temperatures closely for food safety. It is the responsibility of the operator to make sure that food is maintained at a safe temperature for serving.
6. Turn heat shelf off when not in use. To disconnect appliance, turn controls off and remove plug from power source.

CLEANING

NOTE: Proper maintenance plays an important part in the life span and functioning of the heat shelf. To maintain appearance and increase the service life, the warmer should be cleaned at least daily.

1. Unplug the power cord and let warmer cool before cleaning or moving.
2. Wipe the stainless steel top surface interior clean, damp cloth or stainless steel cleaner.
3. **Do not immerse in water or other liquid.** Do not clean with a water jet.
4. If soap or chemical cleaners are used, be sure they are completely rinsed away with clear water, immediately after cleansing. Chemical residue could damage warmer.

TROUBLESHOOTING

| | |
|------------------------------------|--|
| Won't Heat | Check that unit is plugged in |
| | Check that thermostat is turned to desired heat setting |
| Product Cold/Not to Temperature | Adjust thermostat to increase temperature. |
| Product too Hot | Adjust thermostat to decrease temperature. |
| Unit Blows Fuse or Circuit Breaker | Check to make sure circuit is not overloaded. Unplug from power and check for short circuits |

SERVICE INSTRUCTIONS

Repair: To avoid serious injury or damage, do not repair the heat shelf or replace a damaged power cord yourself. Repairs must be coordinated through NEMCO Food Equipment customer service at 1-(800) 782-6761.

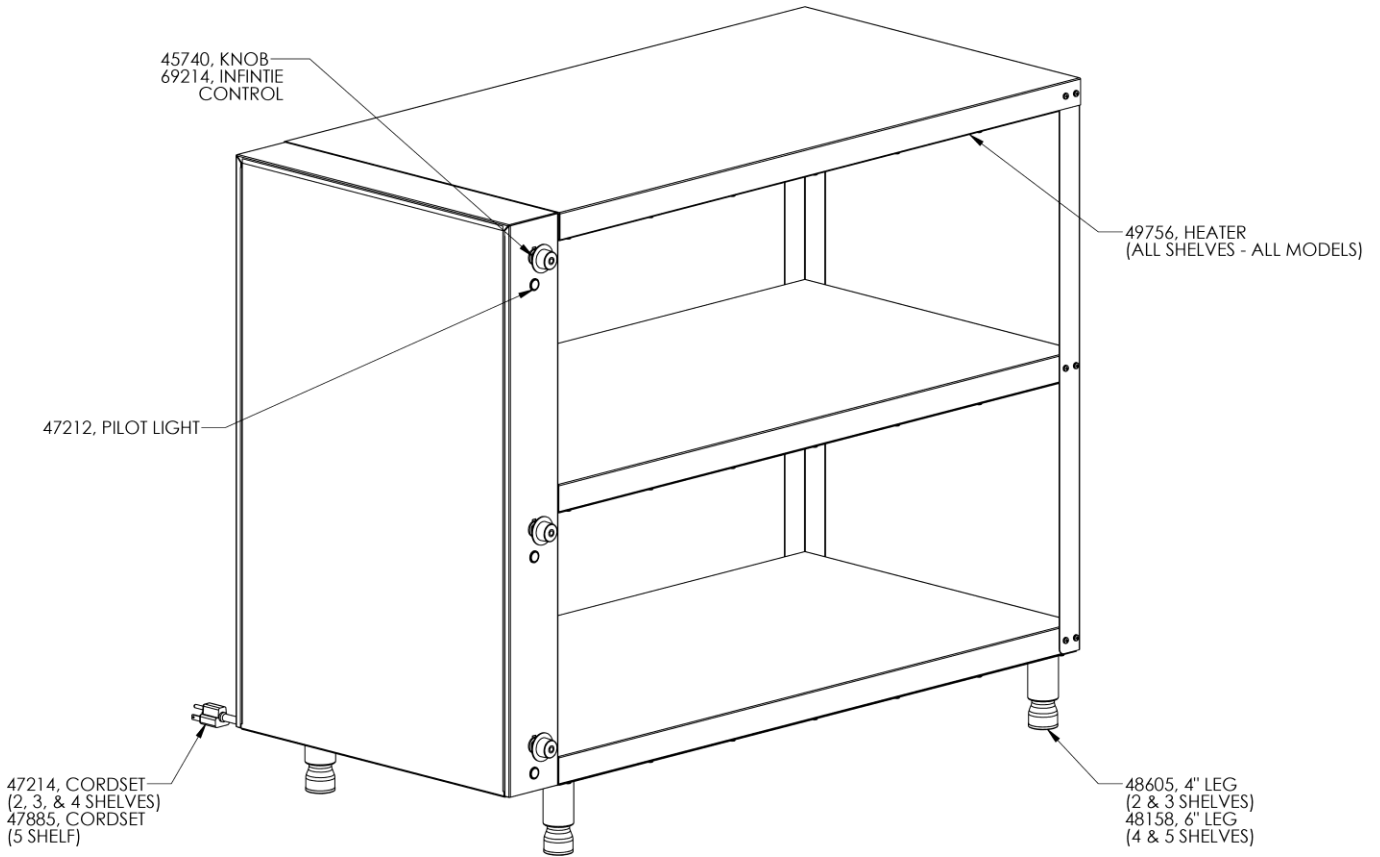

Schematic shown is for the 5 Shelf Warmer. Wiring for all other models is the same less a series of components based on the number of shelves.

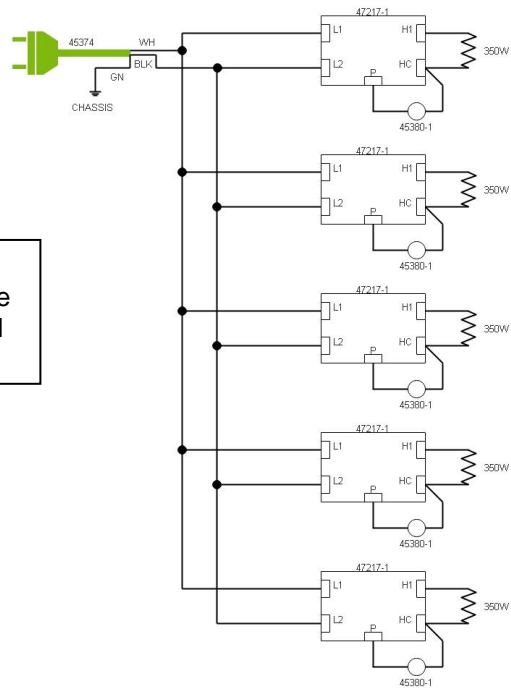

NEMCO FOOD EQUIPMENT 301 Meuse Argonne, Hicksville, OH 43526
 Phone: (419) 542-7751 Fax: (419) 542-6690 Toll free: 1-800-782-6761
www.nemcofoodequip.com

