

Item No. _____

Quantity _____

nemco® | FOOD EQUIPMENT

Model No.
6205
6205-240
Counter Top
Pizza Oven



6205

Get the incredible bake of an authentic deck-oven in this unique counter top model. The 240 volt unit bakes fast and recovers quickly. This oven is equipped with stone decks that distribute heat evenly and produce a better quality food product. Nemco's Pizza Oven may also be used to cook a variety of frozen foods (with the use of a screen or pan) including pretzels, cookies, biscuits, pies, hors d'oeuvres and much more. Our compact space saving design allows these units to be placed on narrow counter tops.

The front, top, sides and back of the unit are constructed of brushed stainless steel. The interior of the cabinet is mirror finished stainless steel and the bottom is galvanized steel. The cooking cavity is insulated with one inch thick high-temperature insulation and the unit is vented with an automatic fan that is located in the base of the unit. The fan also prevents the unit from becoming too hot to touch. General operating instructions are screen printed on the front of the unit for ease of operation. These powerful units are designed to meet your performance standards!



Standard Features:

- Stainless steel construction
- Heavy duty Incoloy tubular heating elements
- Bulb & capillary thermostat with a temperature range of 300-700° F
- Manual 60 minute bell timer
- Two removable 19" Fibrament decks
- Automatically vented with a powered fan
- Four-inch adjustable legs
- Single phase
- Six foot cord and plug provided
- One year parts and labor warranty

NEMCO Food Equipment, LTD.
 301 Meuse Argonne
 P.O. Box 305
 Hicksville, OH 43526
 Phone (419) 542-7751
 FAX (419) 542-6690
www.nemcofoodequip.com

**Model No.
6205
6205-240**

AIA File No.

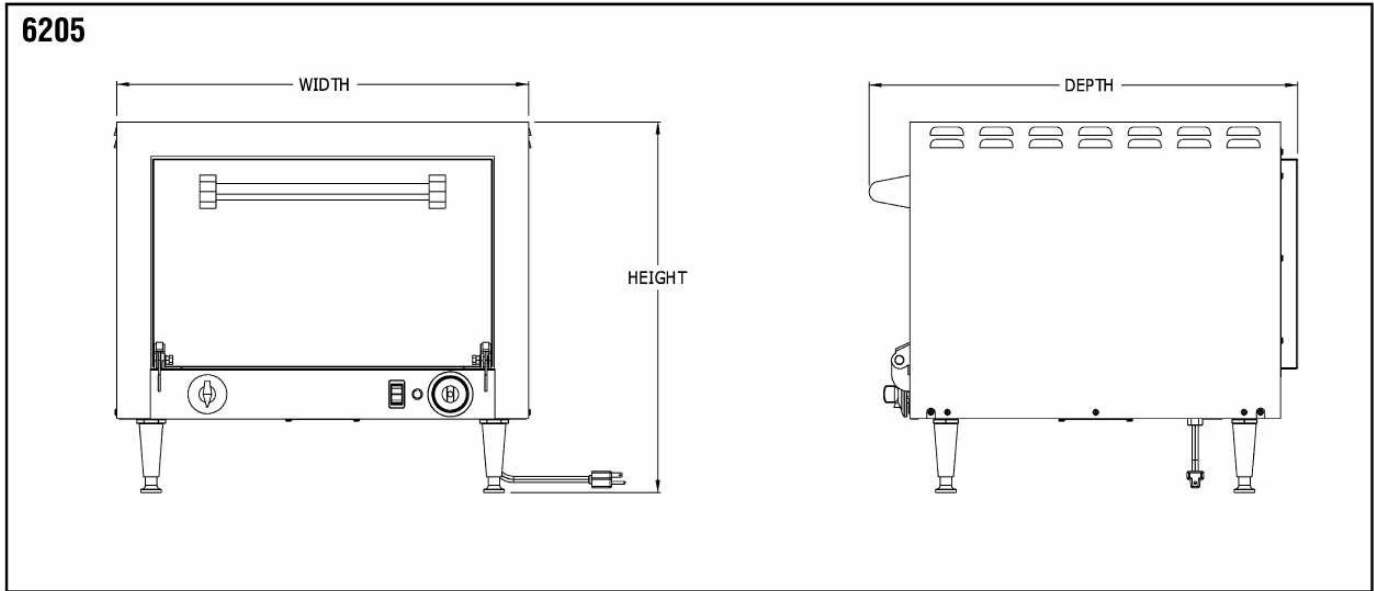

Specifications:

Model No.	Pre-heat time	Width Inches/(cm)	Depth Inches/(cm)	Height Inches/(cm)	Voltage	Rated Wattage	Nominal Amps	NEMA Plug	Unit Weight lbs./(Kg)	Shipping Weight lbs./(Kg)
6205	60 min @ 500 degrees	25 1/4 (64.1)	26 (66)	22 (56.0)	120	1800	15.0	5-15P P	106 (48.2)	130 (59.1)
6205-240	15 min @ 500 degrees	25 1/4 (64.1)	26 (66)	22 (56.0)	240	5400	22.5	10-30P P	106 (48.2)	130 (59.1)

Accessories:

Model No.	Description
<input type="checkbox"/> 66785	Set Of Four Stainless Steel Legs
<input type="checkbox"/> 66795	Baking Stone, 19"W x 19"D

Typical Specifications

Electric countertop pizza ovens shall have a stainless steel body (except bottom of unit which is aluminized steel) and interior and be equipped with a thermostatic control and Incoloy tubular heating element. The unit shall have a one inch thick high-temperature insulation and be vented with a fan. The unit shall have a maximum heat setting of 700° F. The units shall operate on 120 or 240 volts and have a wattage of 1800 @ 120 volts and 5400 @ 240 volts. A 6' cord and plug shall be furnished for easy installation. Electric pizza ovens shall carry the certification of ETL Testing Laboratories and shall be listed with the National Sanitation Foundation.