

## Operating and Maintenance Instructions

**6140 - Dual 1/3rd Size Soup Warmer**

**6145 - Single 1/3rd Size Soup Warmer**

### INTRODUCTION

1. Please read instructions before using this appliance.
2. When using electrical appliances, basic precautions should always be followed to reduce the risk of fire, electric shock and injury.
3. Clean machine thoroughly before and after all uses following cleaning instructions below.

### ELECTRICAL REQUIREMENTS

Plug warmer into a grounded outlet with correct voltage and sufficient power capacity. Refer to the product label (serial plate) on the warmer for voltage and wattage requirements.

### SAFETY INSTRUCTIONS

**Warning!** All power must be disconnected at power source before any service procedure is performed.

1. This appliance is hot when in use. To avoid burns, do not let bare skin touch hot surfaces. Keep combustible materials, such as drapes and other furnishings, away from appliance.
2. Extreme caution is necessary when any appliance is used by or near children and whenever the appliance is left unattended.
3. Always unplug appliance when not in use and before cleaning, adjusting or maintaining this machine. To disconnect appliance, turn controls off and remove plug from power source.
4. Do not operate any appliance with a damaged or altered cord or plug, after the appliance malfunctions, has been dropped, or damaged. Return appliance to an authorized service facility for examination, electrical or mechanical adjustment, or repair.
5. Do not use outdoors. This appliance is not intended for use in wet or moist locations. Never locate appliance where it may fall into water.
6. Connect to properly grounded outlets only. Avoid the use of extension cords. Do not run cord under carpeting, runners, or the like. Arrange cord away from traffic area and where it will not be tripped over.
7. To reduce the risk of fire, it is recommended that the unit is placed on a non-combustible surface.
8. This appliance has electrical parts. Do not use it in areas where gasoline, paint, or flammable liquids are used or stored.
9. **WARNING! ELECTRIC SHOCK HAZARD! Keep water at recommended level. If the water level is too high, water may overflow when the food containers are inserted. The overflow could enter the electrical compartment and may cause a short circuit or electric shock.**
10. **Hot water and steam in the well can burn the skin. Use protective gloves, mitts or potholders when removing food container or cover. Hot food and water can also cause burns. Handle food carefully.**

### PREPARATION

1. Set warmer on a flat, stable non-combustible surface near the power source.
2. Clean unit thoroughly before use.
3. If unit fails to work properly when first operated call NEMCO customer service at 1-800-782-6761.

### OPERATION

1. Plug cord into grounded electrical outlet of the correct voltage. Electrical shock can occur if appliance is not grounded properly.
2. Fill each WELL to the fill line located **1"** above the bottom of the heat well using very hot water (**1" of water = 4 to 4-1/4 cups / 32 to 36 fluid ounces**). Monitor throughout the day, as water may need to be added.
3. Turn the thermostat setting to the "preheat" setting for 20 minutes.
4. Place the soup in the 1/3rd or 1/6<sup>th</sup> size pan per soup instructions, and install lids.  
**Do not put food product directly into the Food Warmer WELL. Food must always be placed in a pan.**
5. Stir frequently to evenly distribute heat during heat up. Stirring will reduce the amount of time required for the soup to reach serving temperatures.
6. Once the soup has reached the desired serving temperature turn the thermostat setting to "hold".

**Note: It is the responsibility of the operator to monitor the soup for safe cook and serve temperatures.**

THIS UNIT IS DESIGNED TO OPERATE WITH WATER IN THE WELLS. WET OPERATION IS NECESSARY TO MAINTAIN SAFE FOOD TEMPERATURES, FOR MORE EVEN HEAT DISTRIBUTION, LOWER OPERATING COSTS AND LONGER TROUBLE FREE SERVICE. FOOD PANS MUST BE COVERED TO MAINTAIN TEMPERATURE WHEN FOOD IS NOT BEING SERVED.

## SOUP WARMER CLEANING INSTRUCTIONS

**NOTE:** Proper maintenance plays an important part in the life span and functioning of the unit. To maintain appearance and increase the service life, the unit should be cleaned at least once a day. Change the water and clean the wells every 24 hours.

1. Unplug the power cord and let unit completely cool before cleaning or moving.
2. Once the soup warmer has completely cooled, remove the insets.  
**Note:** If insets are difficult to remove, use a thin blunt object to carefully lift one corner of the inset away from the heat well. *Do not use sharp objects, such as a knife, to lift up the corner of the inset.* Once the corner of the inset has been lifted away, remove the inset by lifting it out of the heat well. If heat wells are still warm, it is recommended to use a hot pad when removing warm insets to avoid getting burnt.
3. Carefully empty the water from the unit.
4. Wipe the interior of the well and the exterior of the unit with a soft cloth and a solution of dish detergent and warm water.
5. **Do not immerse warmer in water or other liquid.** Do not clean with a spray nozzle.
6. If soap or chemical cleaners are used, be sure they are completely rinsed away with clear water immediately after cleansing. Chemical residue could damage unit.
7. Do not allow scale build up from hard water.
8. To remove scale, use Chemco De-Limer Lime and Scale Remover.

## SERVICE INSTRUCTIONS

**Repair: To avoid serious injury or damage, do not repair the unit or replace a damaged power cord yourself. Repairs must be coordinated through NEMCO Food Equipment customer service at 1-800-782-6761.**

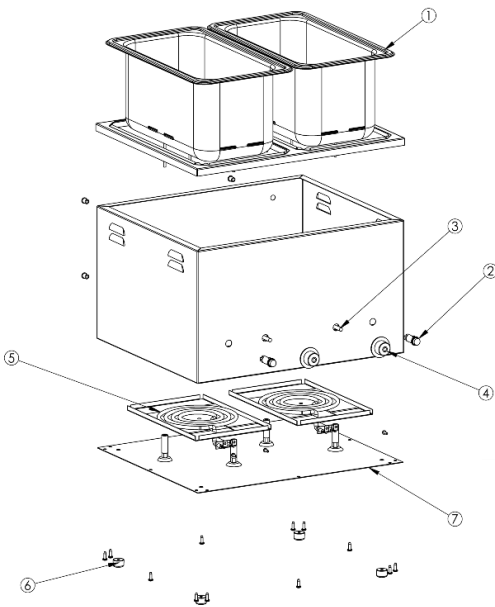

ITEM NO.	PART NUMBER	DESCRIPTION	QTY
1	68757	WELL	2
2	45380-1 45781-1	PILOT LIGHT, 120V PILOT LIGHT, 220V	2
3	45764A	THERMOSTAT	2
4	45740	KNOB	2
5	47669 47669-220	ELEMENT, 120V ELEMENT, 220V	2
6	45955	FOOT	4
7	48841	BOTTOM PANEL	1
NS	45374 46390	POWERCORD, 120V POWERCORD, 220V	1

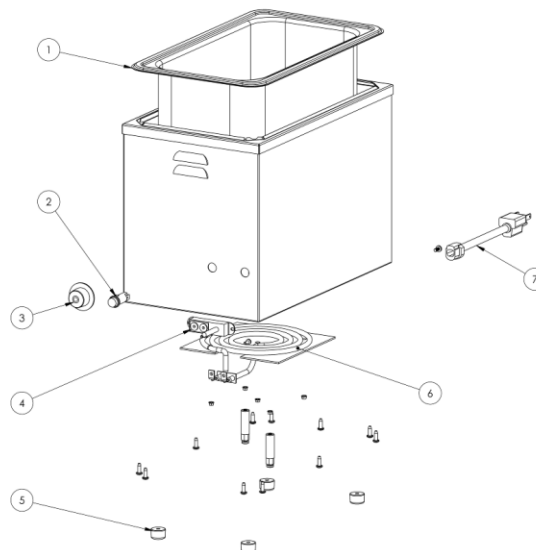

ITEM NO.	PART NUMBER	DESCRIPTION	QTY
1	68757	WELL	1
2	45380-1 45781-1	PILOT LIGHT, 120V PILOT LIGHT, 220V	1
3	45740	KNOB	1
4	45744A	THERMOSTAT	1
5	45955	FOOT	4
6	47669 47669-220	ELEMENT, 120V ELEMENT, 220V	1
7	45374 46390	POWERCORD, 120V POWERCORD, 220V	1

**NEMCO FOOD EQUIPMENT** 301 Meuse Argonne, Hicksville, OH 43526  
 Phone: (419) 542-7751 Fax: (419) 542-6690 Toll free: 1-800-782-6761  
[www.nemcofoodequip.com](http://www.nemcofoodequip.com)



48216-1  
2-2020