



Easy Cartridge Onion Slicer

| | |
|----------------|---------------------|
| 56750-1 | 3/16" SLICES |
| 56750-2 | 1/4" SLICES |
| 56750-3 | 3/8" SLICES |
| 56750-4 | 1/2" SLICES |
| 56750-5 | 1" SLICES |

OPERATING INSTRUCTIONS

Important

1. To get the best operation and life from your machine, please read and comply with these instructions.
2. Clean machine thoroughly before and after each use using cleaning instructions below.
3. Minimize the use of alkaline cleaners as they may cause pitting and dulling of the finish.

Safety Instructions

Remember the blades are **VERY SHARP!** Be careful when handling and operating the machine to keep hands away from the blades

Preparation Instructions

1. The LEVER can be locked in the up position to safely and conveniently clean BLADE ASSEMBLY and PUSHER ASSEMBLY. Raise the LEVER so hole aligns with the holes in LINK BARS and insert the PIN through all three parts.
2. Insert PIN through the unused hole in the handle while the machine is in use so it is not lost.
3. If unit fails to work properly when first operated call NEMCO customer service at 1-800-782-6761.

To Operate

1. Remove the pin from the back hole in the handle in order to mechanically release the machine for operation. Insert the pin through the middle unused hole in the handle while using the machine.
2. Hold LEVER in its upper position and place the produce so it is near the center of the blade pattern. NOTE; the blades are very sharp!
3. Remove hand/fingers from the cutting area and with one quick motion bring LEVER down to cause the PUSHER ASSEMBLY to force the produce through the BLADES then lift and repeat.

To Clean

1. The slicer is easily disassembled for cleaning:
2. To remove the PUSHER ASSEMBLY, remove PIN, move LEVER out of the way and lift PUSHER ASSEMBLY off of the GUIDE RODS. Reassemble by reversing the procedure.
3. To remove the BLADE ASSEMBLIES, lock the PUSHER ASSEMBLY in the up position, and remove the BLADE ASSEMBLIES off of the pins one at a time. Clean the BLADE ASSEMBLIES and replace one at a time over the LOCATING PINS while the handle is still locked in the up position. Now remove the HANDLE from the *locked out* position and continue use.

To Lubricate

Use a bottle of "food grade mineral oil" to lubricate the rods. DO NOT LUBRICATE WITH COOKING or VEGETABLE OIL! Lubricating the rods with any other oil than the oil provided may cause machine to work in an undesirable fashion.

56750-() CARTRIDGE ONION SLICER

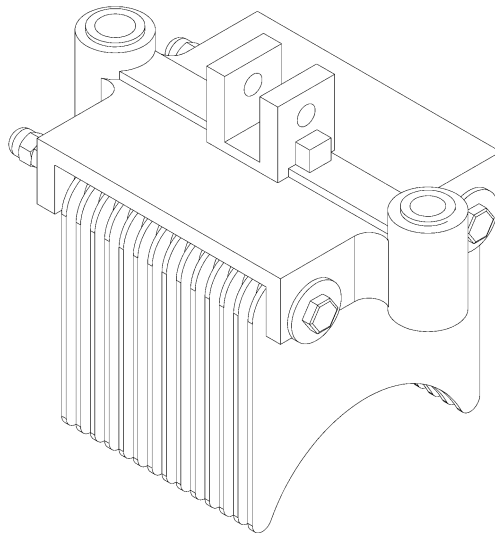
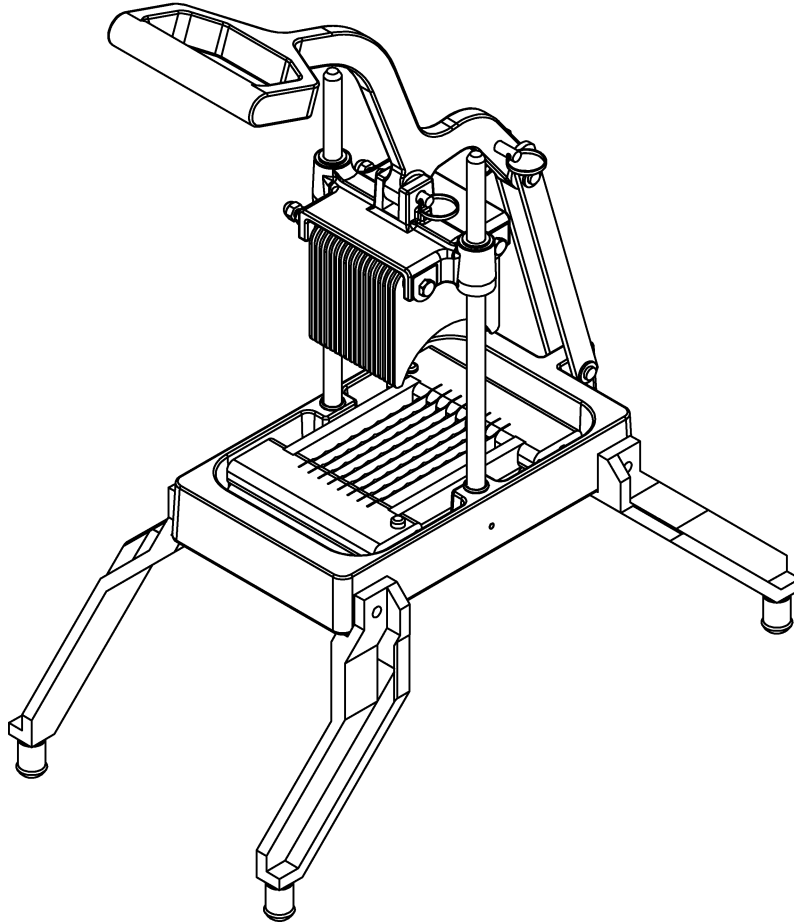

NEMCO FOOD EQUIPMENT 301 Meuse Argonne, Hicksville, OH 43526
Phone: (419) 542-7751 Fax: (419) 542-6690 Toll free: 1-800-782-6761
www.nemcofoodequip.com

47795
3-23-2012