



FOOD EQUIPMENT

Operating and Maintenance Instructions

Easy FryKutter™

Model: 55450-1	¼" Cut	55450-4	4 Section Wedge
55450-2	3/8" Cut	55450-6	6 Section Wedge
55450-3	½" Cut	55450-8	8 Section Wedge

IMPORTANT

1. To get the best operation and life from your machine, please read and comply with these instructions.
2. Clean machine thoroughly before and after each use using cleaning instructions below.
3. Minimize the use of alkaline cleaners as they may cause pitting and dulling of the finish.

SAFETY INSTRUCTIONS

Remember that the blades are **VERY SHARP!** Be careful when handling and operating the machine to keep hands away from the **BLADES**.

PREPARATION

1. The FryKutter™ produce cutter can be mounted on a tabletop or wall, or if portability is a concern it can be mounted on a board to be clamped to a tabletop for use.
2. If this machine replaces one used previously, it is probable that existing mounting holes can be used. If not:
 - a) **TO WALL MOUNT.** Position the machine on the wall where desired. Find a wall stud nearest the position and move the machine so mounting holes on one side of it is over the stud. Mark 4 hole locations and remove the machine. Drill 5/32 diameter holes in these marked locations. Drive the mounting screws with washers under their heads through the mounting holes in the machine and into the holes in the wall.
NOTE: It is important to mount this machine on a stud or very sturdy wall to prevent its falling while in use. The mounting screws provided are long to be able to pass through wallboard, etc. and to engage sturdy material.
 - b) **TO TABLE MOUNT.** Select a solid, sturdy table or work surface to mount this machine on. Position the machine and mark 4 hole locations for mounting. Remove the machine and drill 4 holes as marked – use 5/32 diameter holes if mounting screws are to be used. If other fasteners (not furnished) are preferred, drill holes (1/4" diameter maximum) as appropriate. Use washers under the heads of screws selected.
NOTE: This also applies if the machine is to be mounted on a board for portability.
3. If unit fails to operate properly when first used call NEMCO customer service at 1-800-782-6761.

OPERATION OF Easy FryKutter™

1. Place prepared produce on the **BLADE & HOLDER ASSEMBLY**.
2. Remove hands and fingers from the cutting area.
3. With one quick motion pull down on **LEVER** to cut produce. Occasionally if the produce is very large, or if it is positioned at an angle to the blades, this may have to be repeated to cut it entirely through.
CAUTION: Do not attempt to chop produce larger than the opening in the **BLADE HOLDER**.
4. Clean the machine after cutting is completed, using cleaning instructions below.
5. **NOTE:** Since **BLADE AND HOLDER ASSEMBLIES** for different sized cuts are interchangeable, you may have more than one set available for use. Before cutting be sure that the **PUSH BLOCK** is the correct one to use for the cutting size desired. Gently lower the **PUSH BLOCK** onto the **BLADE AND HOLDER ASSEMBLY** to see that the **PUSH BLOCK GUIDE** rests on the **O'RINGS**. If it does not, something is wrong and must be corrected before chopping produce.
6. To cut ¼" and ½" use ¼" **PUSH BLOCK**.
7. To cut 3/8" use 3/8" **PUSH BLOCK**.

TO CLEAN THE FryKutter™

1. Remove **THUMB SCREWS** to release **PUSH BLOCK**.
2. Remove **WING NUTS** to release the **BLADE AND HOLDER ASSEMBLY** or **BLADE HOLDER** and carefully remove them.
NOTE: The **PUSH BLOCK** will come off with these parts so be alert so it doesn't fall.
3. Thoroughly wash the **PUSH BLOCK** and the **BLADE AND HOLDER ASSEMBLY** or **BLADE HOLDER** and **BLADE**.
4. The **BLADE AND HOLDER ASSEMBLY** may also be totally disassembled for further cleaning as follows:
 - a) Remove **THUMB SCREWS** and the **BLADE HOLDER PLATE**.
 - b) Gently tap the **BLADES** and the **BLADE SPACERS** from the **BLADE HOLDER**.
5. To reassemble:
 - a) Place the **BLADE HOLDER** on a table top with the **BLADE SPACER** pockets upward.
 - b) Insert the 4 **BLADE SPACERS** with their slots toward the inner opening of the **BLADE HOLDER**.
 - c) Insert **BLADES** with sharp edge downward and slots upward.
 - d) Insert **BLADES** with sharp edge and slots downward.
 - e) Reposition **BLADE HOLDER PLATE** and secure with **THUMBSCREWS**.

TO CLEAN THE WEDGER

1. The WEDGER BLADE can be removed from the BLADE HOLDER by removing THUMBSCREWS.
2. Wash the FRAME and associated parts with a cloth, brush, or sponge.
3. NOTE: The machine can be totally disassembled for cleaning (or repair)
 - a) Remove the PIN CLIPS and PINS to release the LEVER and YOKE.
 - b) Then remove nuts and pull GUIDE RODS through the cutting end of the FRAME.
4. Reassemble the machine by reversing the disassembly procedure.

CHOPPING TIPS

1. Cut produce before chopping and place a cut surface against the blades.
2. Onions and tomatoes dice best if cut from top to bottom. They may be cut in half, or if smaller dices are desired, they can be cut several times in this direction.

TO LUBRICATE

1. When necessary, lubricate GUIDE RODS and PINS at each joint utilizing with Mineral Oil, Food Grade Grease, or rub them with Paraffin.
2. DO NOT LUBRICATE WITH COOKING OIL – IT GETS STICKY.

TO REPLACE BLADES OR BLADE SPACERS

If necessary, the BLADES and/or BLADE SPACERS can be replaced. To do this, follow Instruction 4 of TO CLEAN.

55450 - () EASY FRYKUTTER

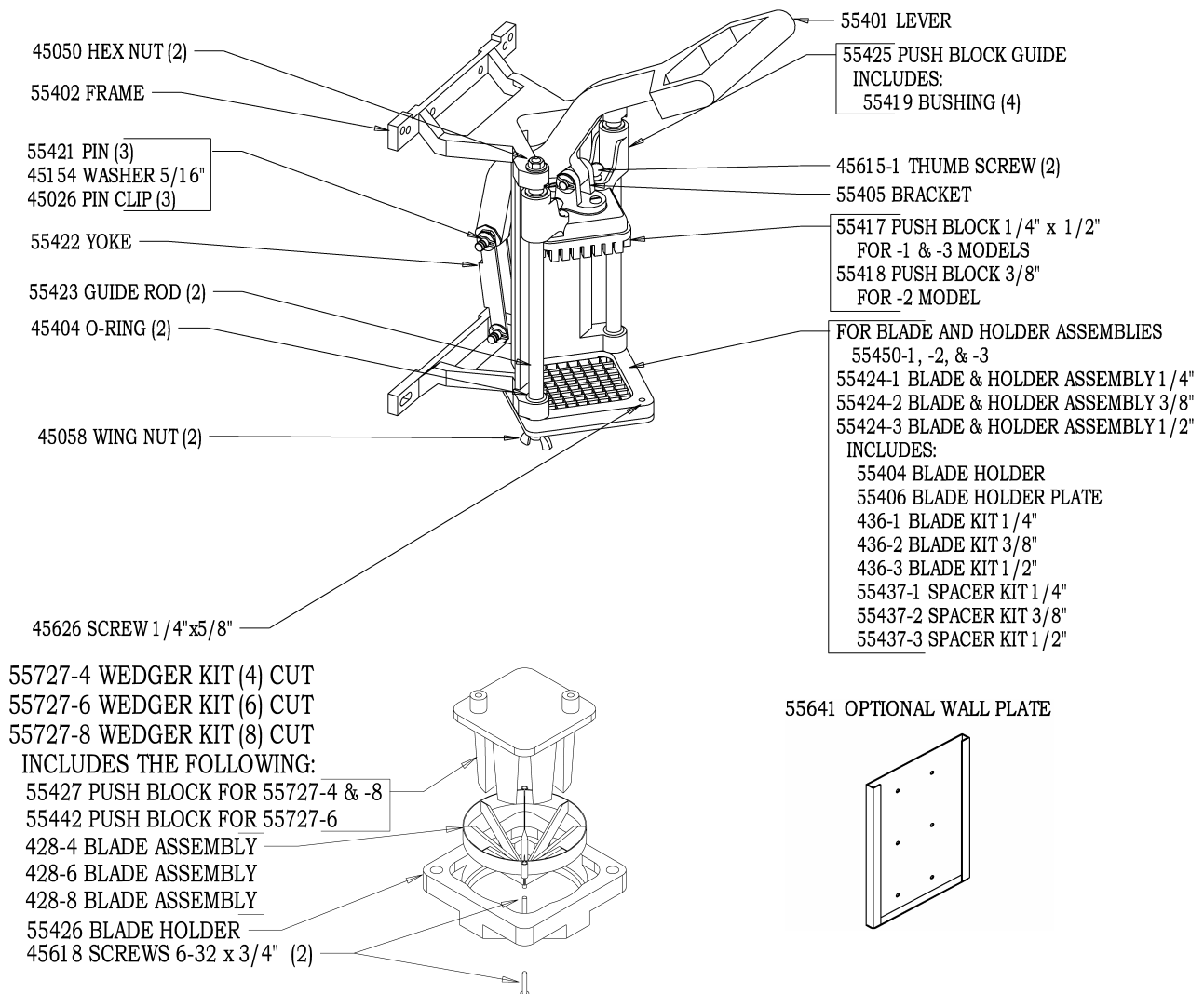

NEMCO FOOD EQUIPMENT 301 Meuse Argonne, Hicksville, OH 43526
Phone: (419) 542-7751 Fax: (419) 542-6690 Toll free: 1-800-782-6761
www.nemcofoodequip.com

