



THE TASTE YOU CAN COUNT ON

**Nieco JF94G Gas
Preventative Maintenance
Instructions**

May 16, 2017

Procedures

Preventative Maintenance should be performed every 12 months

PM should be scheduled either after closing or prior to opening

1. Inspect power supply cord and cap. Check cap for signs of overheating. Check cord for cracks and breaks.
2. Inspect gas hose and connections for cracks and leaks.
3. Inspect all four wheels/casters. Replace any that are bent or not turning properly. Tighten any that are loose.
4. Remove all the daily, weekly and monthly parts from the broiler and inspect. Make note of any broken or abused parts. Straighten any bent sheet metal parts.
5. Remove and clean both upper air boxes.
6. Remove and clean lower burner.
7. If equipped, Inspect the Incendalyst for damage and cleaning. Clean with water only.
8. Fill out PM inspection form.

Required Maintenance

1. Lubricate drive and feeder chains
2. Replace both feeder clutch plastic bushings
3. Replace hot surface igniter
4. Replace flame sensor and wire
5. Remove and inspect (clean if needed) upper air boxes/burner
6. Replace all main burner orifices
7. Replace all pilot orifices, including zip tube orifice
8. Adjust all gas pressures
9. Calibrate broiler



COOKING

Inspection Sheet

Restaurant Number _____

Date: _____

Serial Number _____

Inspected and good condition

Needs follow up service

Needs Immediate service or replacement

Service or replacement completed

COMPONENT CHECK

1	Inspect Power cord and plug
2	Inspect Casters
3	Inspect Panels and all other removable parts
4	Inspect Gas hose and supply. <i>Check hose for gas leaks with bubbles</i>
5	Inspect restraining cable and fastenings
6	Inspect broiler frame (cross rods & supports)
7	Remove and Inspect lower burner
9	Inspect Incendalyst (Catalyst)
10	Remove and inspect upper air boxes
11	Inspect all wiring connections in control box
12	Inspect control box for grease or water (clean if needed)
13	Inspect and adjust both feeders

WIECO
MAIN

Disassembly

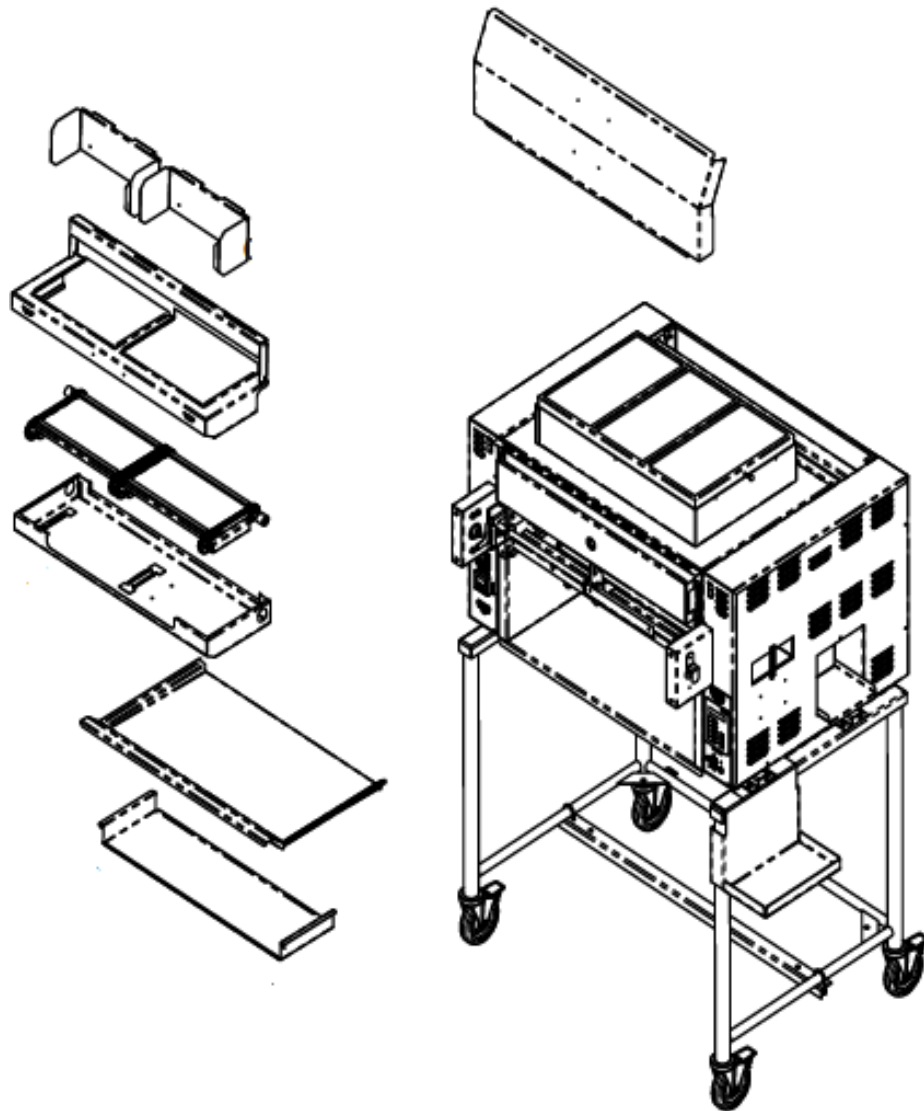

NIECO

Disassembly

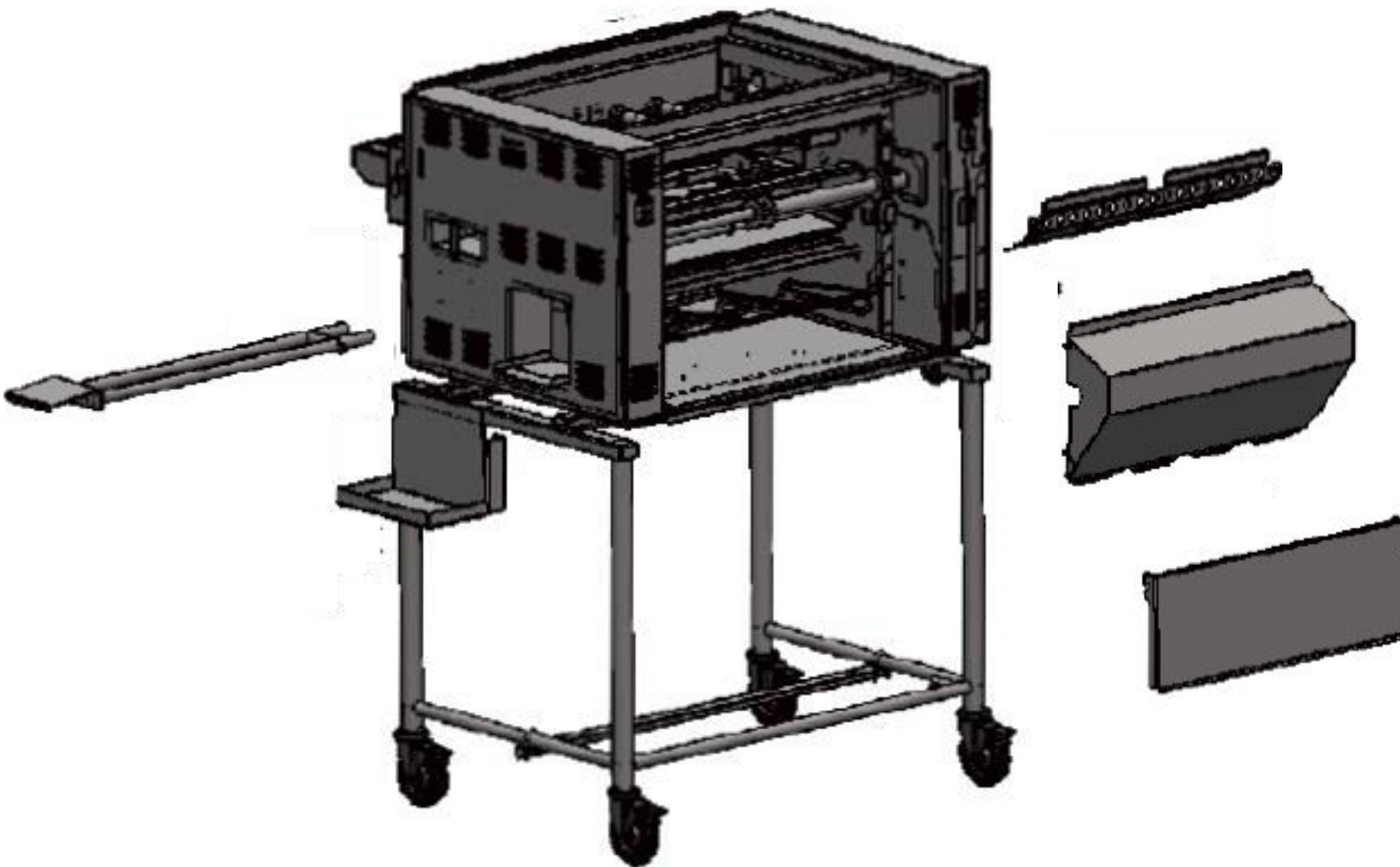

NIECO

Disassembly

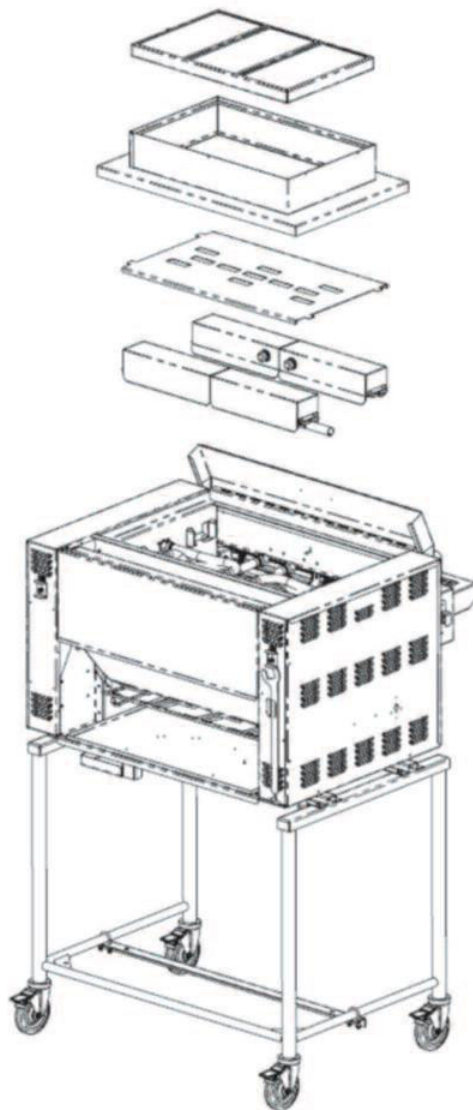

NIECO

Lubricate all Drive Chains

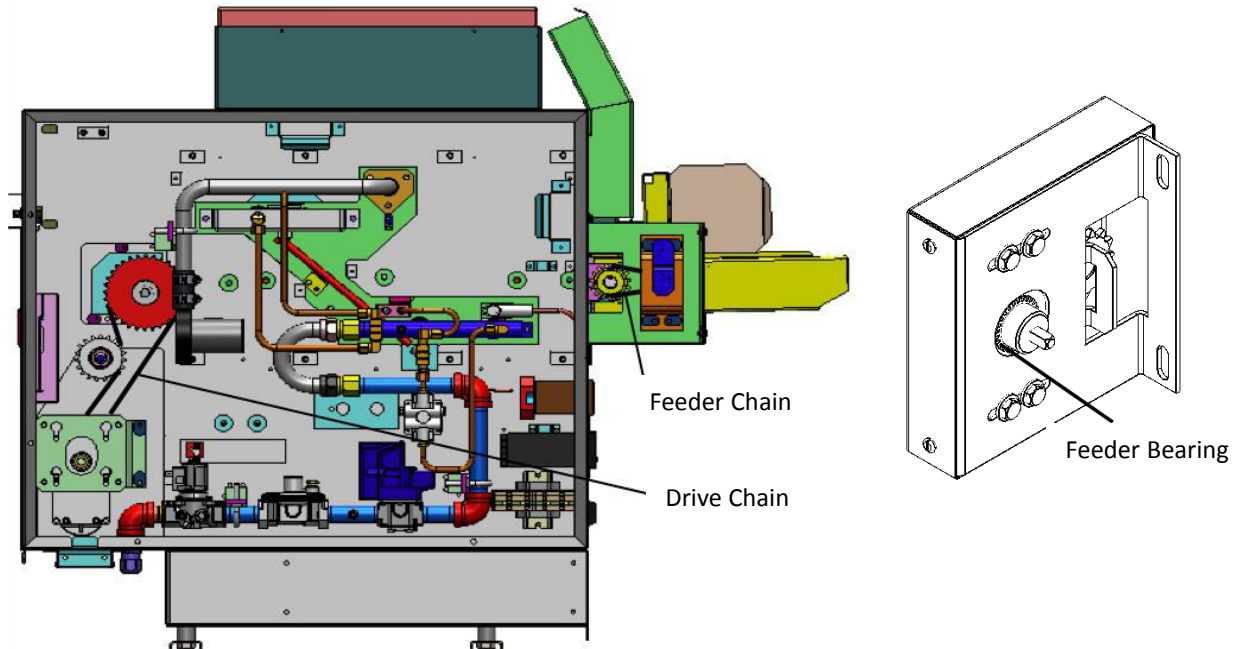

1. Remove side covers.
2. Lubricate Drive Chains. (Main and Flex sides)(We suggest using high temperature grease)
3. Lubricate Feeder Chains. (Main and Flex sides) (We suggest using high temperature grease)
4. Remove feeder drive and replace plastic bushing. (Main and Flex Sides)
5. Install feeder assembly and align pin with feeder.

NIECO
CHAIN

Replace Ignition Parts

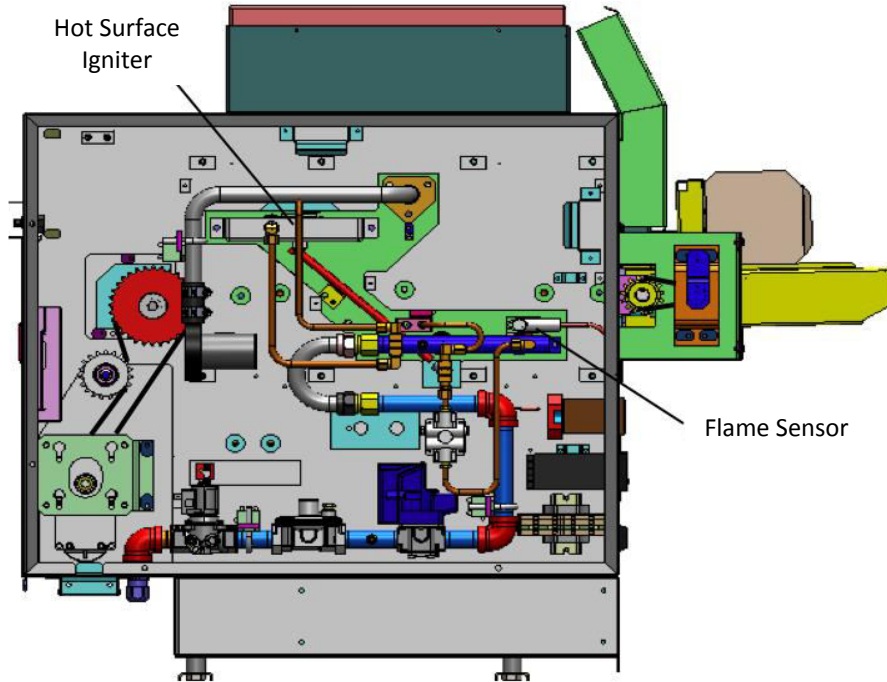

Hot Surface Igniter



Flame Sensor

1. Replace the Hot Surface Igniter
2. Replace the Flame Sensor

NIECO
FIN

Orifice Replacement

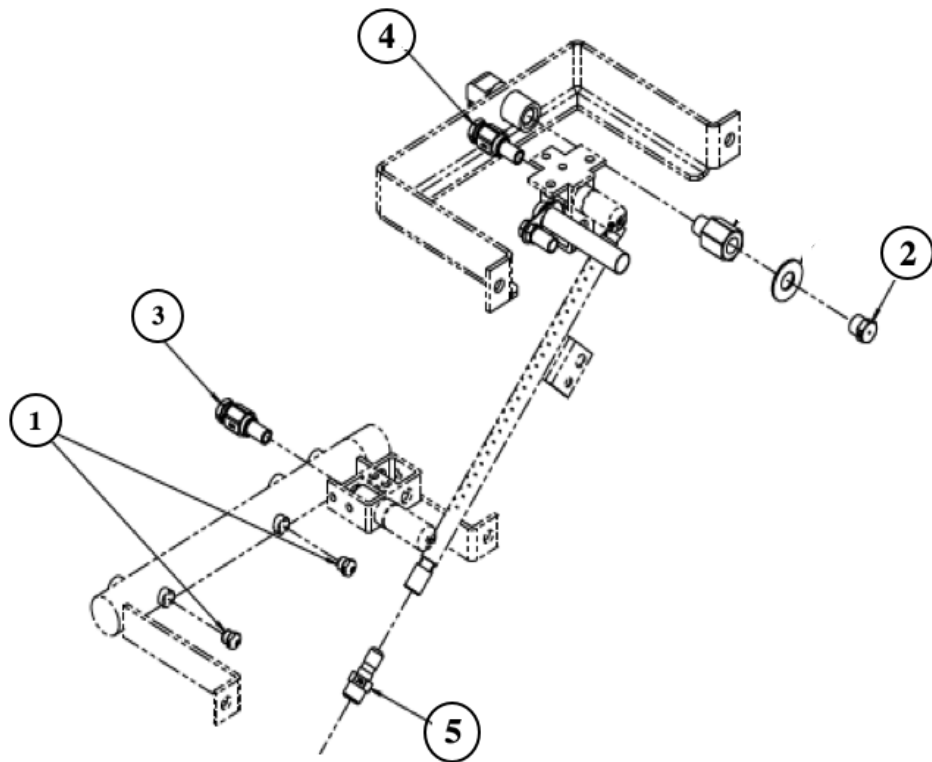

JF94G Natural Gas			
#	Description	Part #	Qty
1	Orifice, lower burner, #42	16590	2
2	Orifice, upper burner #50	18150	1
3	Orifice, lower pilot (5232)	2047	1
4	Orifice, upper pilot (3225)	2182	1
5	Orifice, zip tube #70	22930	1

JF94G LP Gas			
#	Description	Part #	Qty
1	Orifice, lower burner, #53	2066	2
2	Orifice, upper burner #57	18157	1
3	Orifice, lower pilot (4214)	17276	1
4	Orifice, upper pilot (4214)	17276	1
5	Orifice, zip tube #78	23481	1

NIECO

Upper Air Boxes/Burner

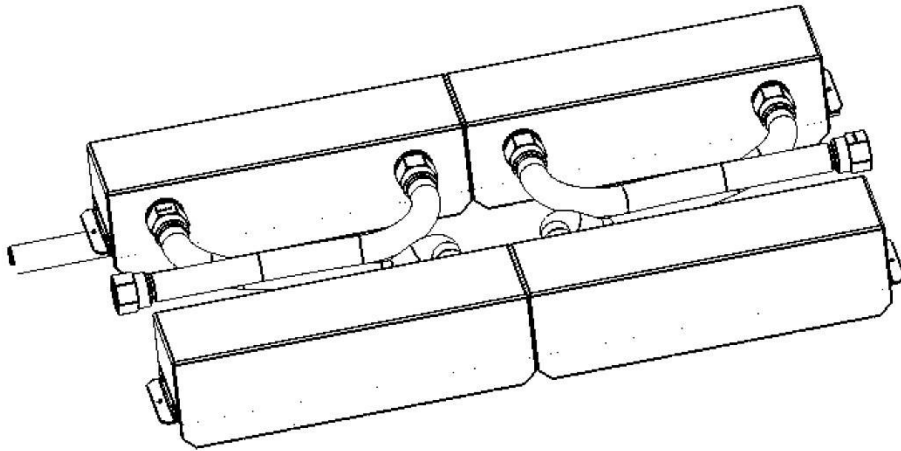

- Disconnect air tubes from supply fitting
- Remove air boxes/burner
- Take air boxes/burner assembly to the sink and clean all air and gas holes
- Allow to dry

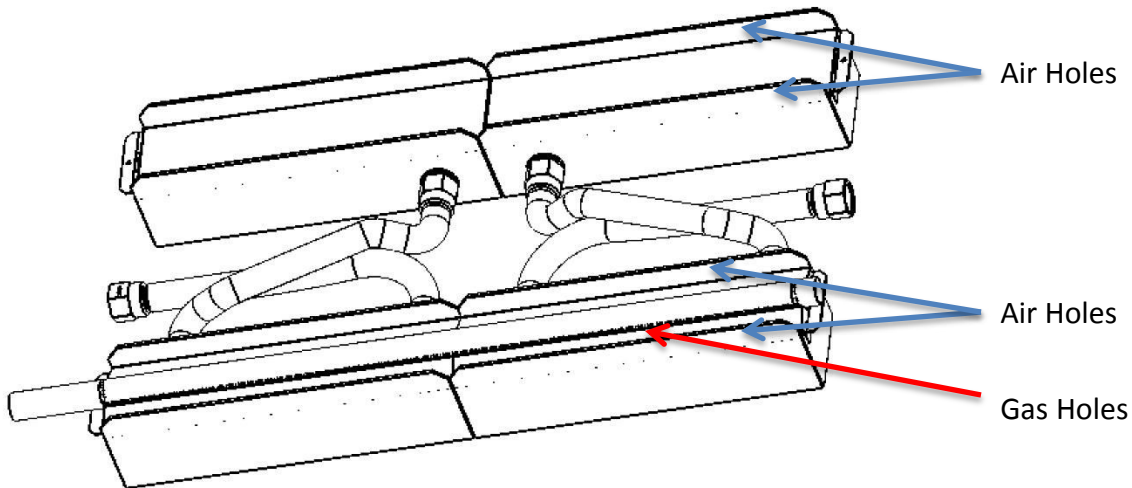

NIECO
FIN

Temperature Control



Actual Temperature

Set Point

Not Used

Adjust Temperature Up

Adjust Temperature Down

Not Used

NIECO

Temperature Control

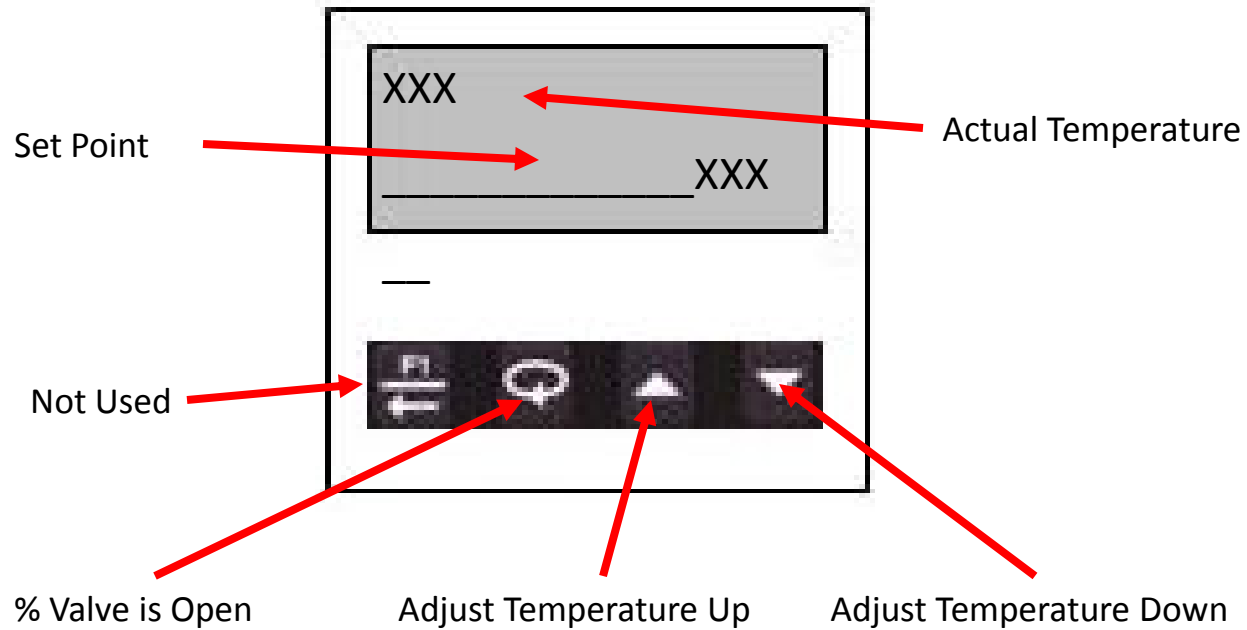

NIECO
FIN

Gas Components

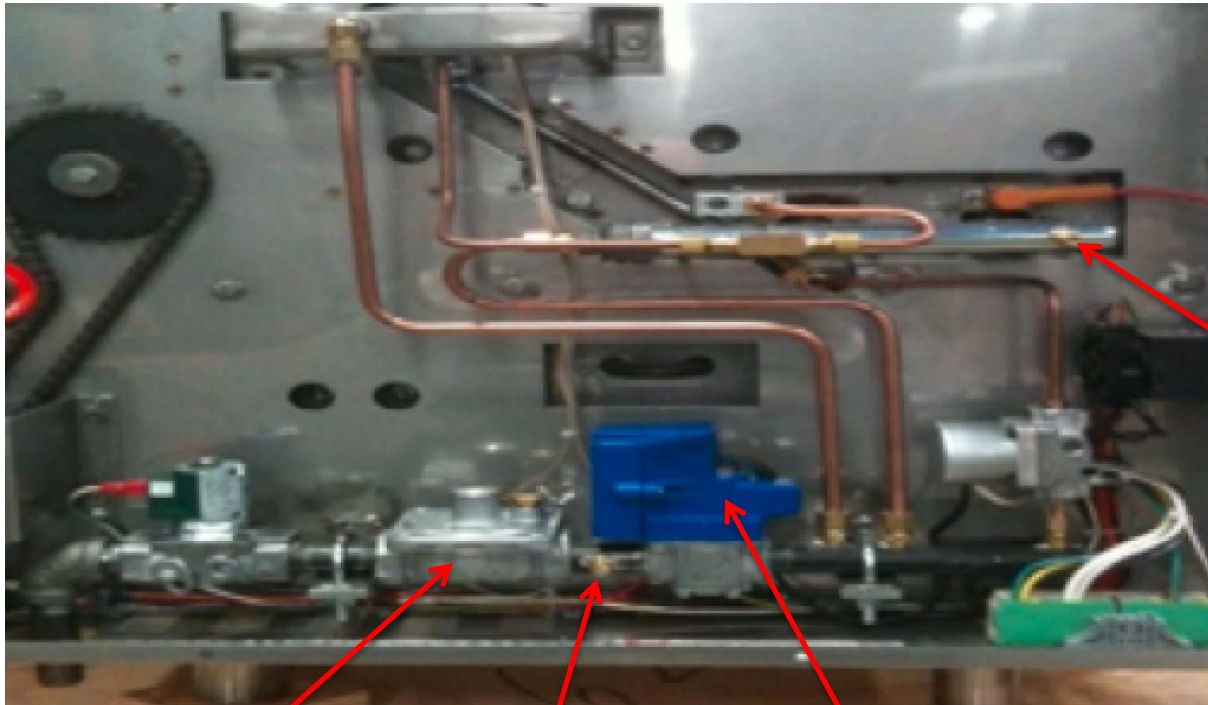

Main gas
Regulator
P/N 2049-A

Pressure Test
Port
P/N 18096

Modulating Gas
Valve
P/N 21316

Manifold Test
Port
P/N 18096

NIECO
MAIN

Modulating Gas Valve

Max Setting /
Adjustment Up Button

Min Setting /
Adjustment Down Button

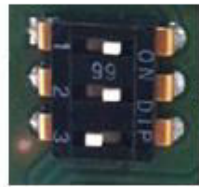

Dip Switch Setting
Switch # 1 & 2 = On
Switch # 3 = Off

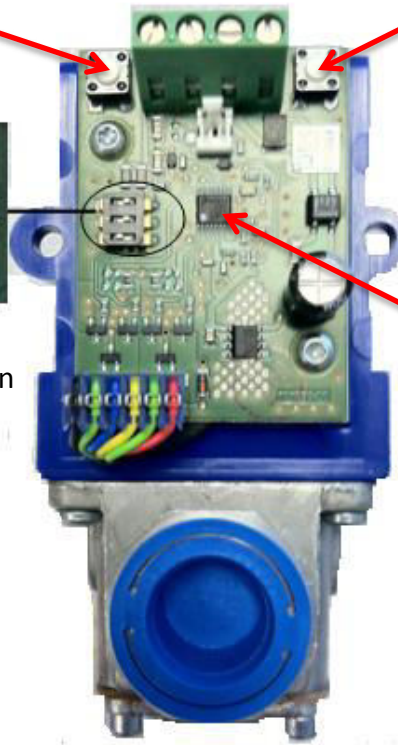

Red Indicator Light

Solid light is for Max Setting
Blinking light is for Min Setting

NIECO
ENGINE

Adjust Gas Pressure

Natural Gas

1. Install your manometer on the test port just past the main gas regulator. Adjust pressure to 5.5" wci.
2. Install your manometer at the pressure tap on the burner manifold.
3. Remove the blue cover on the Modulating Gas Valve.
4. There are two white buttons on this control, one on the inside and one on the outside that adjust the maximum and minimum gas pressure respectively.
5. Turn on the broiler and set the temperature control to 1000 degrees
6. Push and hold the inner button (max) until a solid light on the circuit board comes on. Now use your two buttons to adjust the max (High) gas pressure to 4" wci. The inner button increases the pressure and the outer button lowers the pressure. Once you're satisfied press both buttons and hold until the light goes out., Check your manometer and confirm you are still set at 4" wci.
7. Set the temperature control to 100 degrees.
8. Push and hold the outer button (min) until the circuit board light comes on and blinks. Now use your two buttons to adjust the min (Low) gas pressure to 2.5" wci. The inner button increases your pressure and the outer button lowers pressure. Once you're satisfied press both buttons and hold until the light goes out. Check your manometer and confirm you are still set at 2.5" wci.
9. Calibrate the broiler per instructions.

Tip #1: When adjusting the maximum setting it is good practice to go over the required setting, then adjust down to it.

(The adjustment in the electronic gas control has a range that is higher than the mechanical part that controls the flow. In the event that the pressure is not adjusting continue to hold the button in the desired direction until the electronic control can "catch up" to the mechanical portion of the valve).

Note: This action overrides the temperature control.



COEN

Adjust Gas Pressure

LP Gas

1. Install your manometer on the test port located on the incoming side of the main solenoid valve. Incoming pressure should be between 12" and 14" wci.
2. Install your manometer on the test port just past the main gas regulator. Adjust pressure to 11" wci.
3. Install your manometer at the pressure tap on the burner manifold.
4. Remove the blue cover on the Modulating Gas Valve.
5. There are two white buttons on this control, one on the inside and one on the outside that adjust the maximum and minimum gas pressure respectively.
6. Turn on the broiler and set the temperature control to 1000 degrees
7. Push and hold the inner button (max) until a solid light on the circuit board comes on. Now use your two buttons to adjust the max (High) gas pressure to 9.5" wci. The inner button increases the pressure and the outer button lowers the pressure. Once you're satisfied press both buttons and hold until the light goes out., Check your manometer and confirm you are still set at 9.5" wci.
8. Set the temperature control to 100 degrees.
9. Push and hold the outer button (min) until the circuit board light comes on and blinks. Now use your two buttons to adjust the min (Low) gas pressure to 6.25" wci. The inner button increases your pressure and the outer button lowers pressure. Once you're satisfied press both buttons and hold until the light goes out. Check your manometer and confirm you are still set at 6.25" wci.
10. Calibrate the broiler per instructions.

Tip #1: When adjusting the maximum setting it is good practice to go over the required setting, then adjust down to it.

(The adjustment in the electronic gas control has a range that is higher than the mechanical part that controls the flow. In the event that the pressure is not adjusting continue to hold the button in the desired direction until the electronic control can "catch up" to the mechanical portion of the valve).

Note: This action overrides the temperature control.



COOKING

Calibration

Calibration (Done Monthly)

1. Make sure broiler is assembled completely and properly
2. Set the temperature control to 1000 degrees and allow the broiler to heat for one hour. (do not cook while calibrating)
3. After one hour, set the temperature control to 20 degrees below the actual.
4. Calibration is complete.

NIECO

