

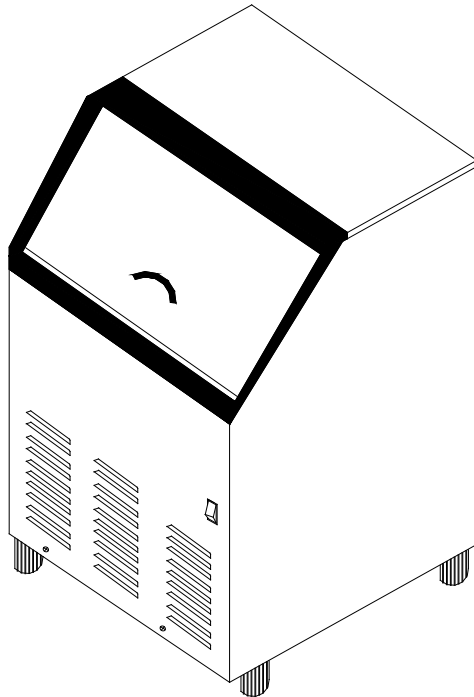

Automatic Ice Maker



User's Manual

The Legacy Companies

3355 Enterprise Ave, Suite 160

Ft Lauderdale, FL

Tel.: 1-877-368-2797

E-mail: sales@thelegacycompanies.com

Models:

MIM70

MIM90

MIM120

TABLE OF CONTENTS

	Page
ICE MAKER SAFETY.....	2
IMPORTANT SAFEGUARDS.....	3-5
TECHNICAL INFORMATION.....	5
INTRODUCTION.....	6
COMPONENT LOCATIONS.....	7
ICE MAKER INSTALLATION.....	8-16
Unpacking.....	8
Location Requirements.....	9
Electrical Requirements.....	11-12
Leveling the Ice Maker.....	12
Water Supply and Drain Connections.....	13-14
Installation Types.....	15-16
OPERATION.....	16-19
Final Checklist before Operation.....	16
Operating Method.....	17
How the Machine Makes Ice.....	17-18
Normal Sounds.....	18-19
Preparing the Ice Maker for Long Storage.....	19
CLEANING AND MAINTENANCE.....	19-27
Exterior Cleaning.....	20-21
Condenser Cleaning.....	21
Interior Cleaning.....	22-24
Ice Making System Cleaning.....	24-26
Control Box.....	26-27
Major function.....	27
TROUBLESHOOTING.....	29-31
LIMITED WARRANTY.....	32

MaxxIce reserves the right to make changes in specifications and design without prior notice.

ICE MAKER SAFETY

Your safety and the safety of others are very important.

We have provided many important safety messages in this manual and on your appliance. Always read and obey all safety messages.



This is the Safety Alert Symbol. This symbol alerts you to potential hazards that can kill or injure you and others. All safety messages will follow the Safety Alert Symbol and either the words "**DANGER**", "**WARNING**" or "**CAUTION**".



Danger means that failure to heed this safety statement may result in severe personal injury or death.



Warning means that failure to heed this safety statement may result in extensive product damage, serious personal injury, or death.



Caution means that failure to heed this safety statement may result in minor or moderate personal injury, or property or equipment damage.

All safety messages will alert you to what the potential hazard is, tell you how to reduce the chance of injury, and let you know what can happen if the instructions are not followed.

IMPORTANT SAFEGUARDS



Before the ice maker is used, it must be properly positioned and installed as described in this manual, so read the manual carefully. To reduce the risk of fire, electrical shock or injury when using the ice maker, follow basic precautions, including the following:

DANGER

- Plug into a grounded 3-prong outlet; do not remove grounding prong, do not use an adapter, and do not use an extension cord.
- It is recommended that a separate circuit, serving only your ice maker, be provided. Use receptacles that cannot be turned off by a switch or pull chain.
- Do not connect or disconnect the electric plug when your hands are wet.
- Never clean ice maker parts with flammable fluids. These fumes can create a fire hazard or explosion. And do not store or use gasoline or other flammable vapors and liquids in the vicinity of this or any other appliance. The fumes can create a fire hazard or explosion.
- Before proceeding with cleaning and maintenance operations, make sure the the unit is disconnected and the water line is shut off. (EXCEPTION: ice maker is in cleaning mode).
- Replace all panels before operating after servicing or maintenance.
- Unplug the ice maker or disconnect power before cleaning or servicing. Failure to do so can result in electrical shock or death.
- Do not attempt to repair or replace any part of your ice maker unless it is specifically recommended in this manual. All other servicing should be referred to a qualified technician.

WARNING

- When you disassemble the front cover, don't overexert, or the leads connected with the power switch can be torn from the switch.
- Use two or more people to move and install ice maker. Failure to do so can result in back or other serious injury.
- To ensure proper ventilation for your ice maker, the front of the unit must be completely unobstructed. Choose a well-ventilated area with temperatures above 55°F (13°C) and below 90°F (32°C). This unit MUST be installed in an area protected from the elements, such as wind, rain, water spray or drips.
- The ice maker should not be located next to ovens, grills or other sources of high heat.
- The ice maker must be installed with all electrical, water and drain connections in accordance with state and local codes. A standard electrical supply (115 VAC only, 60 Hz, 15 A), properly grounded in accordance with the National Electrical Code

and local codes and ordinances is required.

- Do not kink or pinch the power supply cord between the ice maker and cabinet.
- The circuit breaker rating should be 15 amperes.
- It is important for the ice maker to be leveled in order to work properly. You may need to make several adjustments to level it.
- All installations must be in accordance with local plumbing code requirements.
- Make certain that the pipes are not pinched or kinked or damaged during installation.
- Check for leaks after water line and drain line connection.
- Never allow children to operate, play with or crawl inside the ice maker.
- Although the unit has been tested at the factory, due to long-term transit and storage, the first batch of cubes must be discarded.
- Never turn the water supply tap off when the ice maker is working.
- If the ice maker will not be used for a long time, before the next use it must be thoroughly cleaned. Carefully follow instructions as provided for cleaning or use of sanitizing solution. Do not leave any solution inside the ice maker after cleaning.
- DO NOT touch the condenser fins. The condenser fins are sharp and can be easily damaged.
- DO NOT use solvent-based cleaning agents or abrasives on the interior. These cleaners may transmit taste to the ice cubes, or damage or discolor the interior.
- The ice machine cleaner contains acids. DO NOT use or mix with any other solvent-based cleaner products. Use rubber gloves to protect hands and protective eye wear. Carefully read the material safety instructions on the container of the ice machine cleaner.
- Do not use this apparatus for anything other than its intended purpose.

SAVE THESE INSTRUCTIONS

Electrical Connection

Do not, under any circumstances, cut or remove the third (ground) prong from the power cord. For personal safety, this appliance must be properly grounded. The power cord of this appliance is equipped with a 3-prong (NEMA 5-15P) grounding plug that mates with a standard 3-prong (NEMA 5-15R) grounded wall receptical to minimize the possibility of electric shock hazard from the appliance. Have the wall receptical and circuit checked by a qualified electrician to make sure the it is properly grounded. When a old style 2-prong wall receptical is encountered, it is your responsibility and obligation to have it replaced with a properly grounded 3-prong receptical. The ice maker should always be plugged into its dedicated outlet which has a voltage rating that matches the rating label on the appliance. This provides the best performance and also prevents overloading wiring circuits which can be a fire hazard from overheated wires. Never unplug your ice maker by pulling on the power cord. Always grip the plug firmly and pull straight out from the

receptical. Repair or replace immediately all power cords that have become frayed or otherwise damaged. Do not use a cord that shows cracks or abrasion damage along its length or at either end. When moving the ice maker, be careful not to damage the power cord.

Extension Cord

DO NOT use an extention cord with this appliance.

TECHNICAL INFORMATION

Model:	MIM70	MIM90	MIM120
Rated power:	120VAC~60Hz	120VAC~60Hz	120VAC~60Hz
Ice-making rated current:	6.7A	7.3A	7.5A
Ice-harvest rated current:	11.2A	11.7A	11.8A
Refrigerant:	R134a	R134a	R134a
	6.88oz	8.96oz	9.92oz
	195.04g	254.01g	281.23g
High Side Pressure:	320psi	320psi	320psi
	22.5Kg/cm	22.5Kg/cm	22.5Kg/cm
Low Side Pressure:	120psi	120psi	120psi
	8.44Kg/cm	8.44Kg/cm	8.44Kg/cm

The technical data and performance index listed above should be used for reference only. They are subject to change.

*The actual quantity of ice produced per day can vary with room and water conditions.

INTRODUCTION

The MaxxIce MIM series Ice Maker finds wide application in households, bars, restaurants, hotels, supermarkets, etc. It produces crystal-clear, gourmet cube ice, and offers convenience for homeowners and hotel guests. An insulated ice storage bin is built into the ice maker.

This user's manual is intended as a resource for persons installing, using and servicing the MIM series. It contains valuable information on safety and maintenance. Maxx Ice strongly recommends that this manual be kept in a place where it can be accessed when needed.

The MaxxIce ice maker is designed and manufactured according to the highest standards of safety and performance. It meets or exceeds the safety standard of UL563 and sanitation standard of NSF12.

The Legacy Companies assumes no liability or responsibility of any kind for products manufactured by MaxxIce that have been altered in any way, including the use of any parts and/or other components not specifically approved by The Legacy Companies. MaxxIce reserves the right to make design changes and/or improvements at any time. Specifications and designs are subject to change without notice.

IMPORTANT SAFETY INSTRUCTIONS

WARNING: To reduce the risk of fire, electric shock, or injury when using your ice maker, follow these basic precautions:

- Plug into a grounded 3-prong outlet.
- Do not remove grounding prong.
- Do not use an adapter.
- Do not use an extension cord.
- Disconnect power before cleaning.
- Disconnect power before servicing.
- Replace all panels before operating.
- Use two or more people to move and install ice maker.

SAVE THESE INSTRUCTION

COMPONENT LOCATIONS

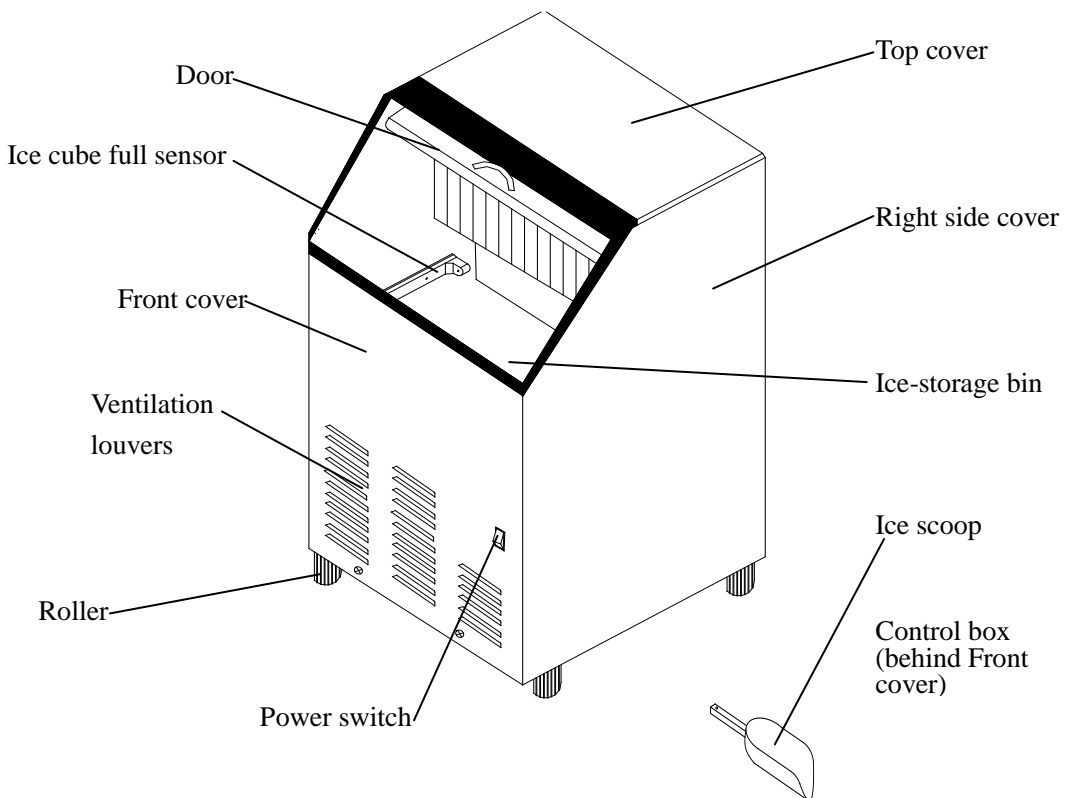

ICE MAKER INSTALLATION

Unpacking



Excessive Weight Hazard

Use two or more people to move and install ice maker. Failure to do so can result in back or other serious injury.

Remove packaging materials

NOTE: Do not remove any permanent instruction labels or the data label on your ice maker.

Remove tape and glue from your ice maker before using.

- To remove any remaining tape or glue, rub the area briskly with your thumb. Tape or glue residue can also be easily removed by rubbing a small amount of liquid dish soap over the adhesive with your fingers. Wipe with warm water and dry.
- Do not use sharp instruments, rubbing alcohol, flammable fluids, or abrasive cleaners to remove tape or glue. These products can damage the surface of your ice maker.

Cleaning before use

After you remove all of the packaging materials, clean the inside of your ice maker before using it. See "Interior cleaning" in the Cleaning and Maintenance section.

Location Requirements

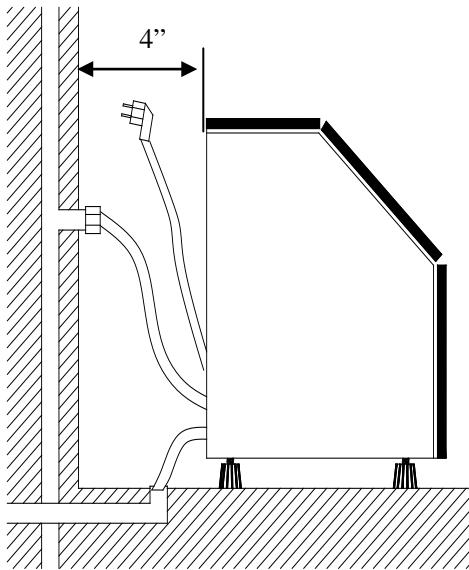

To ensure proper ventilation for your ice maker, the front of the unit must be completely unobstructed. Allow at least 4" (101mm) clearance at rear, and 0.6" (15mm) at the top and sides for proper air circulation. The installation should allow the ice maker to be pulled forward for servicing if necessary.

When installing the ice maker under a counter, follow the recommended spacing dimensions shown. Place electrical and water supplies and drain fixtures in the recommended locations as shown.

Choose a well-ventilated area with temperatures above 55°F (13°C) and below 90°F (32°C). This unit **MUST** be installed in an area protected from the elements, such as wind, rain, water spray or drips.

The unit should not be located next to ovens, grills or other sources of high heat.

Installation of the ice maker requires a cold water supply inlet of 6.35mm (¼ in.) soft copper tubing with a shut-off valve. A gravity-drain system provided with the unit can be used.

NOTE: Runoff water can also be drained into a sink via a pump – not included – when a gravity drain is not available.

The ice maker requires a continuous water supply with pressure between 14.5psi and 72.5psi (0.1 MPa and 0.5 MPa). The temperature of the water feeding into the ice maker should be between 41°F (5°C) and 77°F (25°C) for proper operation.

WARNING

Normal operating ambient temperature should be between 55°F (13°C) to 90°F (32°C). Normal operating water temperature should be between 41°F (5°C) and 77°F (25°C). Operation of the icemaker for extended periods outside of these normal temperature ranges may affect production capacity.

In general, it is always a good idea to filter the water. A water filter, if it is of the proper type, can remove taste and odors as well as particles. Where water is very hard, softened water may result in white, mushy cubes that stick together.

NOTE: Deionized water is not recommended.

The ice maker must be installed with all electrical, water and drain connections in accordance with state and local codes.

The unit should be located on a firm and level surface. It is important for the ice maker to be leveled in order to work properly. If needed, you can adjust the height of the ice maker by adjusting the feet. See the “Leveling the Ice Maker” section.

A standard electrical supply (120 VAC only, 60 Hz, 15 A), properly grounded in accordance with the National Electrical Code and local codes and ordinances is required.

The MIM70 ice maker can be used as a built-in appliance too.

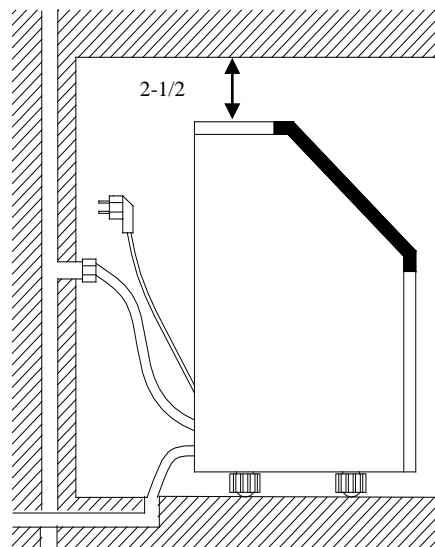
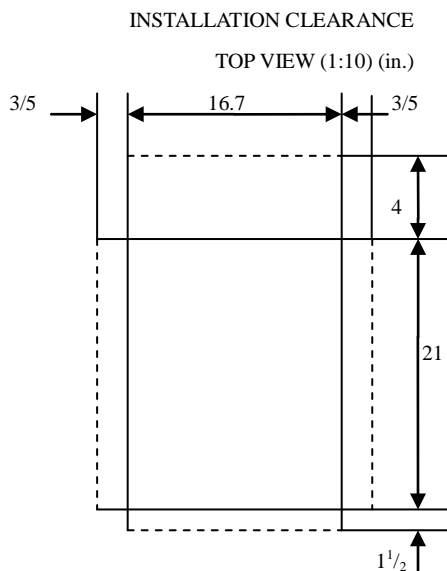



To ensure proper ventilation for your ice maker, the front of the unit must be completely unobstructed. Allow at least 4” (101mm) clearance at rear, and 0.6” (15mm) at the top and sides for proper air circulation. The installation should allow the ice maker to be pulled forward for servicing if necessary.

When installing the ice maker under a counter, follow the recommended spacing dimensions shown. Place electrical and water supplies and drain fixtures in the recommended locations as shown.

NOTE: Do not kink or pinch the power supply cord between the ice maker and cabinet.

Electrical Requirements

 DANGER 

<p>Electrical Shock Hazard</p> <p>Plug into a grounded 3-prong outlet.</p> <p>Never remove the ground prong from the plug.</p> <p>Never use an adapter.</p> <p>Never use an extension cord.</p> <p>Failure to follow these instructions can result in death, fire, or electrical shock.</p>

Before you move your ice maker into its final location, it is important to make sure you have the proper electrical connection.

A standard electrical supply (120 VAC only, 60 Hz, 15 A), properly grounded in accordance with the National Electrical Code and local codes and ordinances is required.

It is recommended that a separate circuit, serving only your ice maker, be provided. Use receptacles that cannot be turned off by a switch or pull chain.

The circuit breaker should be rated no larger than 15 amperes.

Recommended grounding method

For your personal safety, this appliance must be grounded. This appliance is equipped with a power supply cord having a NEMA 5-15P 3-prong grounded plug. To minimize possible shock hazard, the cord must be plugged into a mating NEMA 5-15R 3-pronged, wall receptacle, grounded in accordance with the National Electrical Code and local codes and ordinances. If a mating wall receptacle is not available, it is the personal responsibility of the customer to have a NEMA 5-15R wall receptacle installed by a qualified electrician.

Leveling the Ice Maker

It is important for the ice maker to be leveled in order to work properly. You may need to make several adjustments to level it.

This type of ice maker has a combination of 4 feet/rollers on the bottom. It can be easily moved anywhere by one person. You will find the feet/roller combinations very useful for cleaning and sanitizing the surface on which the ice maker is installed because it allows you to move the unit and have easy access to the surface to be cleaned.

NOTE: Once you are ready to install it in a cabinet or directly on the floor, you must adjust the feet to level the ice maker and lock the rollers. If the floor is level, just revolve the two front feet to touch the floor. (See illustration.)

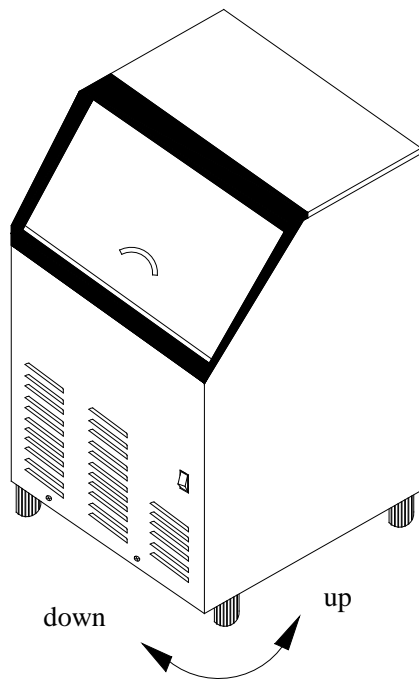

Water Supply and Drain Connections

The water supply and drain should be ready at the point of installation. A wall outlet directly behind the ice maker will make under-counter installation easier.

NOTE:

1. *All installations must be in accordance with local plumbing code requirements. Professional installation is recommended.*
2. *Make certain that the pipes are not pinched or kinked or damaged during installation.*
3. *Check for leaks after connection.*

Tools required:

- ½" (13mm) open-end wrench
- Phillips style screwdriver

Connecting the water line:

1. Turn off main water supply. Turn on nearest faucet long enough to drain the line of water.
2. Find a ½" (13mm) to ¾" (19mm) vertical cold water pipe near the installation location. The distance should be less than 10 feet (3.5M). The water supply pipe provided with the ice maker is about 10 feet (3.5M) in length.
3. A shut-off valve must be installed to the main water supply. If the water tap has a plain piece of copper tubing, attach a ¼" (6.35mm) O.D. compression union to the tubing and remove the nut.
4. Connect the fittings of the water supply pipe to the tap and water inlet valve. Tighten ½ turn with the appropriate sized wrench.
5. Turn on main water supply and tap. Check for water supply connections leaks. Tighten any connections (*including connections at the valve*) or any fittings that leak.

Connecting the drain line:

A gravity drain system is used in this type ice maker.

NOTE: When there is a drain line near the ice maker, it is the best choice to drain the water through the drain water pipe provided with icemaker.

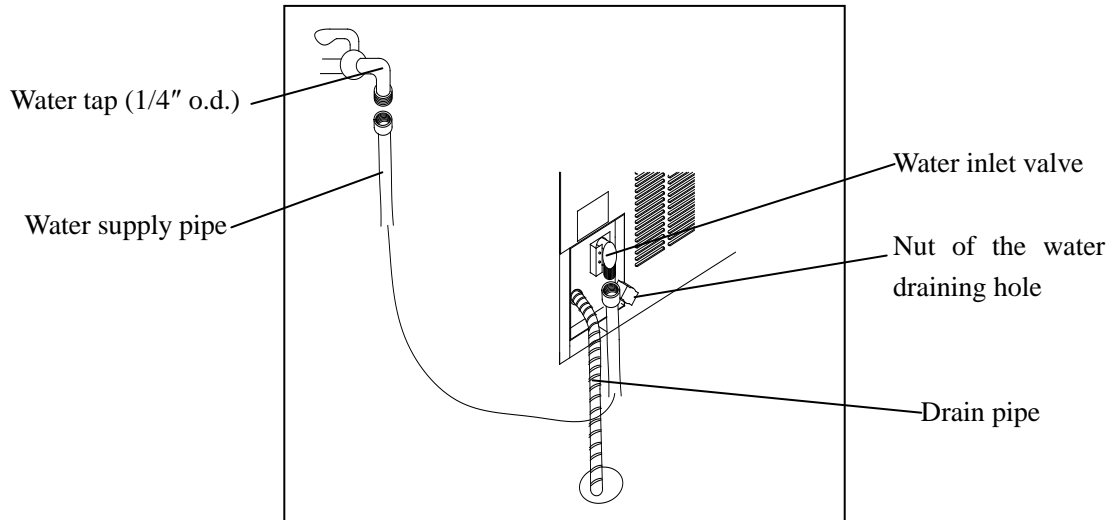

1. Find the floor drain near the ice maker. The distance should be less than 10 feet (3.5M) as the length of the long drain water pipe provided with the ice maker is about 10 feet (3.5M).
2. All horizontal runs of drain lines must have a fall of $\frac{1}{4}$ " per foot (6.35mm per 30.5cm). An air gap will likely be required between the ice maker drain tube and the drain/waste receptacle. A stand pipe with a trap below it would be acceptable for the drain/waste receptacle. A floor drain is also acceptable.
3. Pour 1 gallon of water into the ice storage bin to check for leaks at all drain connections and at the nut of the drain water hole. Tighten any connections or fittings that leak.

NOTE: Poor drainage will cause a high rate of ice melting in the ice storage bin.

Installation Types

This ice maker has been designed for Mobile (free-standing), Enclosed, or Built-in (sealed) installation.

Mobile installation:

A mobile installation will allow you to install the icemaker free-standing in any place you desire provided you have access to a water supply and drainage facilities. You must follow the stated instructions for

- a- Electrical requirements
- b- Water supply and drain connections
- c- Leveling the icemaker.

Enclosed installation:

An enclosed installation will allow you to install the ice maker under a cabinet, or in a kitchen cabinet provided the required clearance space around the ice maker is respected. This installation has the same requirements as a mobile installation.

The unit should be placed in the cabinet by sliding it in the cabinet's opening and leveled properly.

NOTE: For the Mobile and Enclosed installations you must use flexible water and drain connections to the water supply and drain. This will allow the moving of the ice maker for cleaning and/or servicing. Use the water hose and drain hose supplied with the unit for these connections.

Built-in installation:

When the ice maker is to be built-in, the following additional items must be observed.

1. Place ice maker in front of installation location. Remove the feet and place the unit flat on the floor or on a platform depending on your installation requirements.
2. The water supply pipe and drainpipe must be plumbed before connecting to the ice maker.
3. Turn on main water supply and tap. Check for water supply connection leaks. Tighten any connections (*including connections at the valve*) or fittings that leak.
4. Pour 1 gallon (3.79L) of water into the ice storage bin to check leaks at all

- drain connections and the nut of the drain water hole. Tighten any connections or fittings that leak.
5. If electrical outlet for the ice maker is behind the cabinet, plug in the ice maker.
 6. Push the ice maker into position.
 7. Pour 1 gallon (3.79L) of water to the ice storage bin to check if the drainpipe is kinked or pinched.
 8. Seal all around the cabinet to the floor with an approved caulking compound.

OPERATION

Final Check List before Operation

1. Have all packing materials and tape been removed from the interior and exterior of the ice maker?
2. Did you clean the ice storage bin?
3. Have the installation instructions been followed, including connecting the machine to water, drain and electricity?
4. Has the machine been leveled? Feet locked?
5. Is the ice maker in a site where the ambient temperature is between 55°F (13°C) and 90°F (32°C) and the water temperature within 41°F (5°C) and 77°F (25°C) all year round?
6. Has the water supply pressure been checked to ensure a minimum of 14.5psi and 72.5psi (0.1 MPa and 0.5 MPa)?
7. Is there at least a clearance of 4" (101mm) at the rear, and 0.6" (15mm) at the sides and top for proper air circulation?
8. Has the power supply voltage been checked or tested against the data label rating? And has proper grounding been installed in the ice maker?
9. Is the ice maker plugged in?
10. Did you turn on the main water supply and tap?
11. Did you check leaks to all water supplies and drainpipe connections?

Operating Method

1. Switch on the Power switch on the front panel. The light will be on. The ice maker will start working automatically and feeding water.
2. After the first feeding of the water, the machine will automatically go to the ice making stage, and the sound of water spraying will be heard.
3. Ice will be harvested to the ice storage bin. When the storage bin is filled with ice cubes, the ice maker will automatically stop working. The machine will restart making ice once the storage bin is less than full.

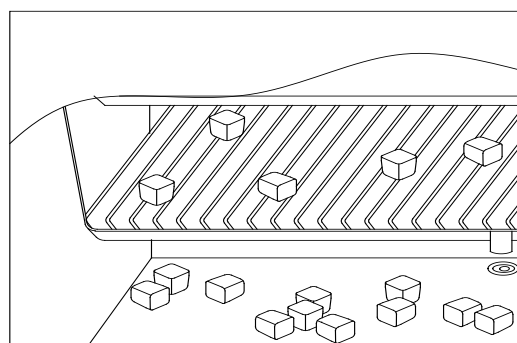
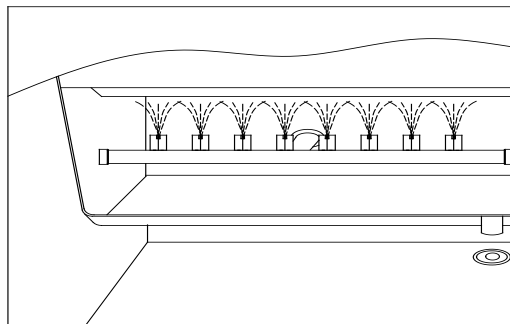

NOTE:

- *Although the unit has been tested at factory, due to long-term transit and storage, the first batch of cubes must be discarded.*
- *Never turn the water supply tap off when the icemaker is working.*

How the Machine Makes Ice

There are two distinct cycles: freeze and harvest.

Freeze: During the freeze cycle the compressor is pumping refrigerant, the fan motor is blowing air, and the water pump is circulating water. When the evaporator surface gets to the setting temperature, the ice maker stops the freeze cycle and begins the harvest, approximately 20 minutes.

Harvest: During the harvest cycle; the compressor is still operating, the water pump has stopped and the hot gas valve and water inlet valve are energized. The

hot gas valve and water inlet valve open to warm up the freezing surface, allowing the cubes to fall into the bin. Once completed, the freeze cycle begins repeatedly until the ice has satisfied the maximum level in the bin, then the water and compressor are shut down until sufficient ice is drawn below the bin level sensor and the cycle again resumes.

How the machine uses water

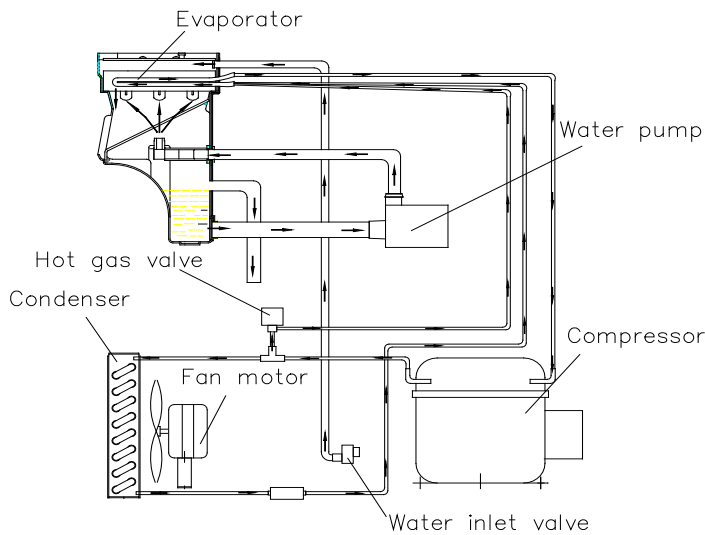

The ice maker begins with a fixed charge of water that is contained in the water bin. As the water is sprayed against the freezing evaporator surface, the portion of water that does not contain mineral impurities will freeze and stick to the ice cube molds.

The water containing impurities falls back into the water bin. Gradually, during the freezing portion of the ice-making cycle, the water in the water bin will become highly concentrated with mineral impurities.

During the harvest cycle, the fresh water flows into the machine to dilute the bin water, and to rinse the concentrated minerals down the drain.

Normal Sounds

Your new ice maker may make sounds that are not familiar to you. Most of the new sounds are normal. Hard surfaces like the floor, walls and cabinets can make the sounds seem louder than they actually are. The following describes the kinds of sounds that might be new to you and what may be making them.

- You will hear a swooshing sound when the water valve opens to fill the water bin for each cycle.
- Rattling noises may come from the flow of the refrigerant or the water line. Items stored on top of the ice maker can also make noises.

- The high-efficiency compressor may make a pulsating or high-pitched sound.
- Water running from the water bin to the evaporator plate may make a splashing sound.
- Water running from the evaporator to the water bin may make a splashing sound.
- As each cycle ends, you may hear a gurgling sound due to the refrigerant flowing through your icemaker.
- You may hear air being forced over the condenser by the condenser fan. During the harvest cycle, you may hear the sound of ice cubes falling into the ice storage bin.
- When you first start the ice maker, you may hear water running continuously. The ice maker is programmed to run a rinse cycle before it begins to make ice.

Preparing the Ice Maker for Long Storage

If the ice maker will not be used for an extended period of time, or is to be moved to another location, it will be necessary to drain the water from system.

1. Shut off the water supply at the main water source.
2. Disconnect the water supply line from the water inlet valve.
3. Disconnect the drain pipe to the drain line or floor drain.
4. Allow the ice maker to run for an hour or more until all remaining ice cubes have been ejected from the ice maker assembly.
5. Shut off the electric supply at main electrical power source.
6. Screw off the nut of the water drain hole at the back of the machine, drain out water residue completely (*do not loosen or screw off the nut at other times*), then tighten the nut after finishing.
7. Drop the door open to allow for circulation and prevent mold and mildew.
8. Leave water supply line and power cord disconnected until ready to reuse.

CLEANING AND MAINTENANCE

CAUTION

If the ice maker is left unused for an extended period, before the next use it must be thoroughly cleaned. Follow carefully any instructions provided for cleaning or use of sanitizing solution. Do not leave any solution inside the ice maker after cleaning.

Periodic cleaning and proper maintenance will ensure efficiency, top performance, and long life. The maintenance intervals listed are based on normal conditions. You may want to shorten the intervals if you have pets, or the unit is used outdoors, or there are other special considerations.

What shouldn't be done?

Never keep anything in the ice storage bin that is not ice: objects like wine and beer bottles are not only unsanitary, but the labels may slip off and plug up the drain.

What should be kept clean?

There are 4 things to keep clean:

1. The exterior
2. The condenser
3. The interior
4. The ice-making system



WARNING

Before proceeding with cleaning and maintenance operations, make sure the power line of the unit is disconnected and the water line is shut off (EXCEPTION: Ice maker system's cleaning).

Exterior Cleaning

The door and cabinet may be cleaned with a mild detergent and warm water solution such as 1oz (29ml) of dishwashing liquid mixed with 2 gallons (7.5L) of warm water. Do not use solvent-based or abrasive cleaners. Use a soft sponge and rinse with clean water. Wipe with a soft clean towel to prevent water spotting. Stainless steel models can discolor when exposed to chlorine and/or chlorine gas and should be thoroughly rinsed clean. Clean stainless steel models with a mild detergent and warm water solution and a damp cloth. Never use abrasive cleaning agents.

NOTICE: Stainless steel models exposed to chlorine and/or chlorine gas and moisture, such as areas with spas or swimming pools, may show some discoloration of the stainless steel. This is a normal condition.

Condenser Cleaning

A dirty or clogged condenser prevents proper airflow, reduces ice making capacity, and causes higher than recommended operating temperatures that may lead to component failure. Have the condenser cleaned at least once every three months.

1. Unplug the ice maker or disconnect power.
2. Unscrew the screws on the front cover.
3. Grasp the underpart of the right and left side, rise a little, and then pull down.

Notice: Don't overexert the panel removal, the leads connected to the power switch can be damaged or torn from the switch.

4. Locate the condenser surface.

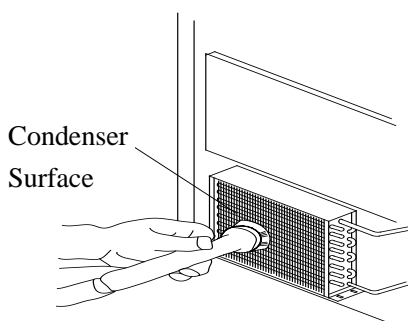

5. Remove dirt and lint from the condenser fins and the unit compartment with a brush attachment on a vacuum cleaner.

6. Reassemble the front cover.

7. Plug in the icemaker or reconnect power.



WARNING

DO NOT touch the condenser fins. The condenser fins are sharp and can be easily damaged.

Interior Cleaning

The ice storage bin should be sanitized occasionally. Clean the bin before the ice maker is used for the first time and reused after stopping for an extended period of time. It is usually convenient to sanitize the bin after the ice making system has been cleaned, and the storage bin is empty.

1. Disconnect power to the unit.
2. Open the door and with a clean cloth, wipe down the interior with a sanitizing solution made of 1oz (29.5ml) of household bleach or chlorine and 2 gallons (7.5L) of hot water 95°F (35°C) to 115°F (46°C).
3. Rinse thoroughly with clear water. The waste water will be drained off through the drainpipe.
4. Reconnect power to the unit.

The ice scoop should be washed regularly. Wash it just like any other food container.

WARNING

DO NOT use solvent-based cleaning agents or abrasives on the interior. These cleaners may transmit taste to the ice cubes, or damage or discolor the interior.

SPRINKLE HEAD CLEANING

NOTE: The sprinkler should only be cleaned when you find that some of the ice cubes are improperly shaped during ice making. Cleaning the ice making system should follow cleaning of the sprinkler.

1. Disconnect power to the unit and open the door.

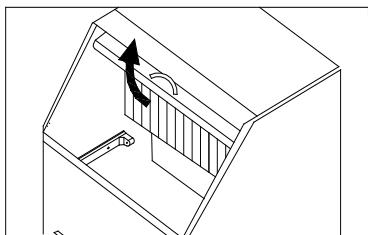

2. Take out the row of flake covers.

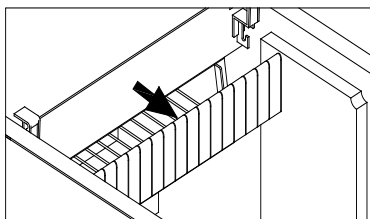

3. Find the sprinkler and the slideway.

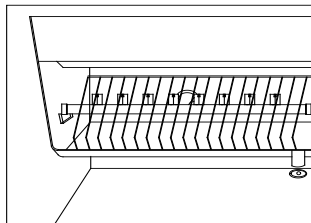

4. Find which water sector is not spraying correctly from the nozzle. If the slideway is the issue, adjust the position of slideway to have all the water sectors free forward to the ice mold. If the water sectors are free, but some sectors is not spraying properly, using a new tooth-brush, clean the gap of the nozzle several times. The water sector should work normally.

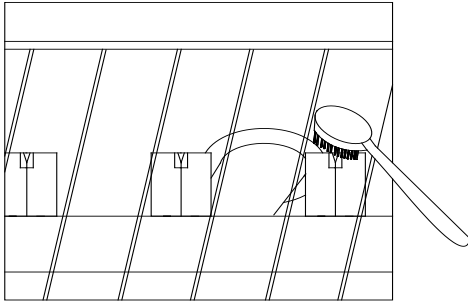

5. Another cleaning method; remove the slideway from the water bin.

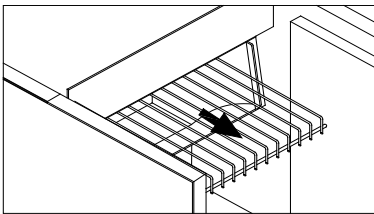

6. Find the sprinkler arm and raise it. Disconnect it from any water tube.

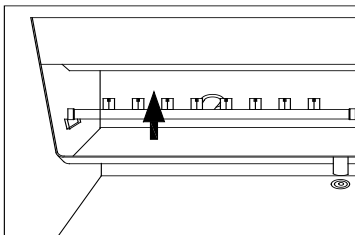

7. A de-scaling solution can be prepared in a plastic basin with a Nickel-Safe Ice Machine Cleaner. Mix 4oz (118ml) of the ice machine cleaner per 1 gallon (3.7L) of warm water.
8. Remove the sprinkler arm from the interior. Thoroughly clean the sprinkler arm by soaking it in the basin filled with the de-scaling solution until it is free of any deposit; use a soft brush to remove any thick or stubborn residue and to help the dissolving action. Rinse under a stream of tap water.
9. Wipe down the interior of the water bin with the de-scaling solution and warm water. Rinse thoroughly with clear water.

10. Reassembly the sprinkler arm, slideway and the flake covers.
11. After the Icemaker System Cleaning procedure below.

Ice Making System Cleaning

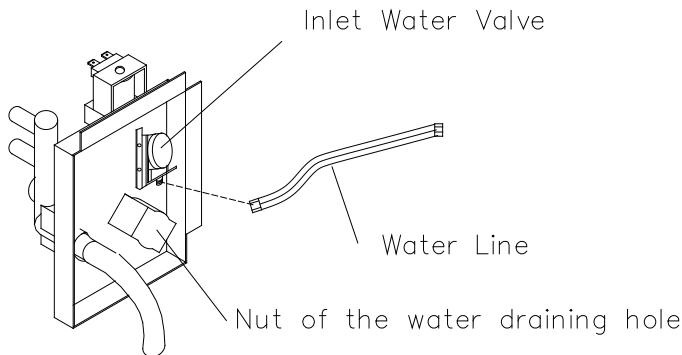

Minerals that are removed from water during the freezing cycle will eventually form a hard scaly deposit in the water system. Cleaning the system regularly helps remove the mineral scale buildup. How often you need to clean the system depends upon how hard your water is. With hard water of 15 to 20 grains/gal. (4 to 5 grains/liter), you may need to clean the system as often as every 3 to 6 months.

1. Turn off power to the ice maker. Keep the ice maker connected to the water supply and drainpipe.
2. Open the door and scoop out all of the ice cubes. Either discard them or save them in an ice chest or cooler. Remove the screws in the front cover, and push forward to remove. Put the front cover against the right side cover.

Notice: Don't overexert, or the leads connected with the power switch can become disconnected.

3. Locate the control box.

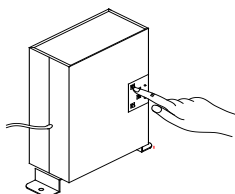

4. Turn on the power to the ice maker. Pour 8oz. (237ml) of Nickel-Safe Ice Maker Cleaning Solution into the water bin. Add 8oz. (237ml) of tap water. After about 5 minutes, depress the "clean" button on the Control Box. (See figure below and following section.) The machine will run the

Automatic Clean Mode.

5. Allow 30 minutes for proper cleaning. After cleaning, shut off the power switch, and unscrew the nut of the water-draining hole. Drain off the waste water to some container, and then screw the nut on tightly when the waste water is fully drained off.
6. Repeat steps 4 and 5 (*without Ice Maker Cleaning Solution*) to rinse the ice making system 3 times.

Note: The use of the Ice Maker Cleaner Solution in the water bin during the rinse is not needed.

WARNING

The ice machine cleaner contains acids.
DO NOT use or mix with any other solvent-based cleaner products.
Use rubber gloves to protect hands. Carefully read the material safety instructions on the container of the ice machine cleaner.

7. Prepare a sanitizing solution made of 1oz (29ml) of household bleach and 2 gallons (7.5L) of hot water 95°F (35°C) to 115°F (46°C). Remove the flake covers and slideway from the water bin and wipe the entire bin inside and out, covering all surfaces.
8. Fill a spray bottle with the sanitizing solution and spray all corners and edges making sure to cover all surfaces with the solution. Soak the flake cover and slideway in the solution and put back in place after drying.
9. Allow the solution to be in contact for at least 3 minutes, and then dry.
10. Repeat step 6 to rinse the ice making system one more time.
11. Reassemble the front cover.
12. Turn on the power. The machine will return to the normal ice making operation. Discard the first batch of ice.

Control Box (See diagram on page 30.)

Instructions for LEDs and buttons:

1. **RED LED:** Ice full indicator light.
When this LED is lit, the ice storage bin is full of ice and the unit will stop working. When ice cubes are taken out of the ice storage bin, clearing the sensor, the red LED will flash for 3 minutes. Then the unit will restart and return to the ice making mode.

2. **GREEN LED:** Ice making indicator light.
When this LED is lit (solid), the unit is working in the ice making mode controlled by a temperature probe on the evaporator. When the green LED is flashing, the unit is working in the ice making mode controlled by a fixed timer.
3. **YELLOW LED:** Ice harvest indicator light.
When this LED is lit (solid), the unit is working in the ice harvest mode controlled by a temperature probe on the evaporator. When the yellow LED is flashing, the unit is working in the ice harvest mode controlled by a fixed timer.
4. **CLEAN button:** When this button is pressed, the unit enters the cleaning mode. The green and yellow LEDs flash together. To stop the cleaning mode, just press the button again.
5. **MODE button:** Mainly for service. When this button is pressed, it can change from ice making mode to ice harvest mode, or from ice harvest mode to ice making mode. You can judge the mode from the status of the green and yellow LEDs.
6. **ICE SIZE ADJUSTMENT:** Turn the screw clockwise, and the size of individual ice cubes will be larger in the next cycle; the cycle time will be longer. Turn the knob counter-clockwise, and the ice size will be smaller in the next cycle.
NOTE: It is not a good idea to adjust the ice size often or for no good reason, because the controller may be damaged.
7. If the red, green and yellow LEDs are flashing together, the machine is not working. Call for service.

NOTE: Avoid letting water contact the control box.

Major Functions

1. Completely automatic operating procedure.
2. When the ice storage bin is full of ice cubes, the machine stops working automatically and starts again after the cubes are removed.
3. The different colors of the LED display indicate various work modes.
4. Indication of failure of major control.
5. The fan motor responds to the ambient temperature. If it is cold, the motor will stop working to keep the cooling system in good working condition.
6. Ice cube size is adjustable.
7. A sensitive probe and accurate timer enhance the performance of the ice maker.

8. Manual clean mode to start or stop the ice making system cleaning.
9. Built-in compressor protection system.

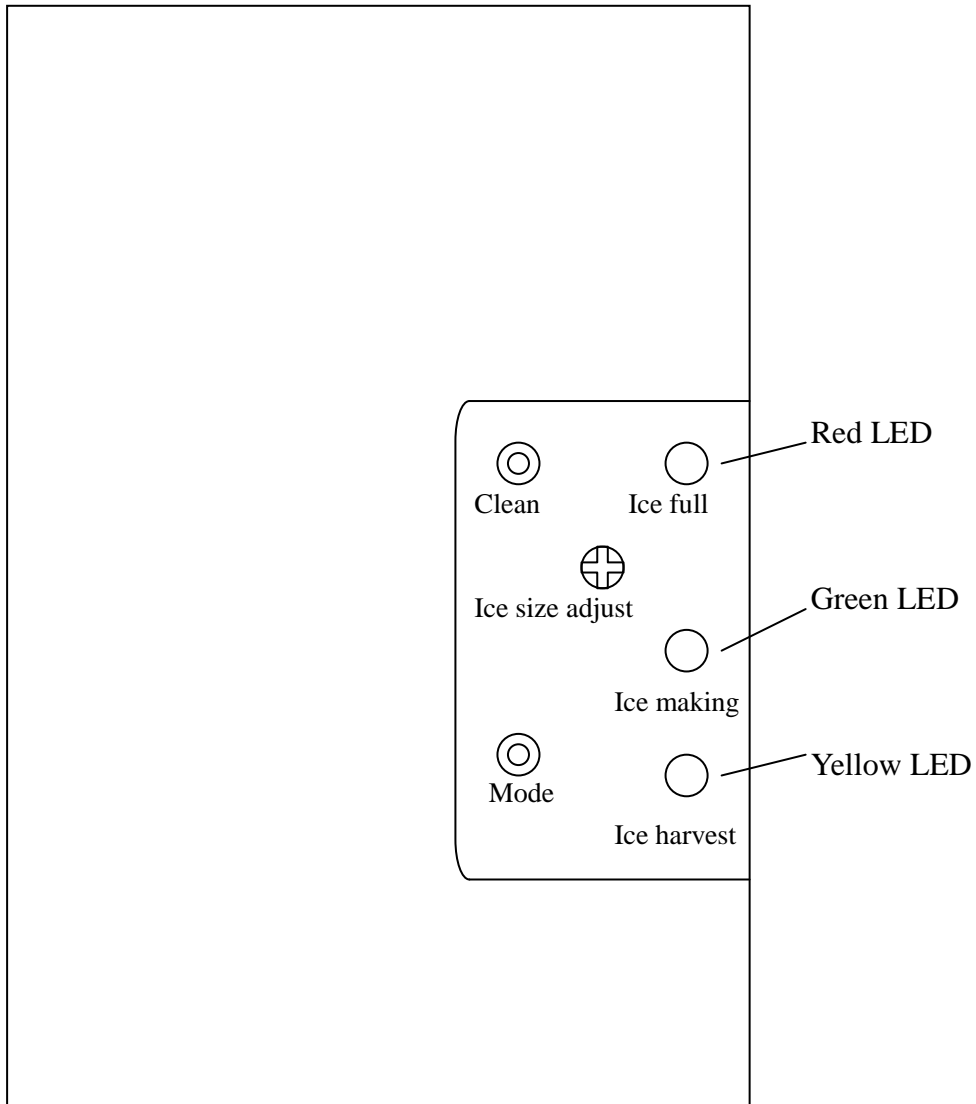

Control box (behind Front Cover)

TROUBLESHOOTING

Before Calling for Service

If the unit appears to be malfunctioning, read through the OPERATION section of this manual first. If the problem persists, check the TROUBLESHOOTING GUIDE on the following pages. The problem could be something very simple which can be solved without a service call.

Troubleshooting Guide

Problem	Possible Cause	Probable Correction
The machine doesn't operate	The ice maker is unplugged.	Plug the ice maker in.
	The fuse is blown.	Replace fuse--if it happens again, call for service to check for a short circuit in the ice maker.
	The ice maker power switch is OFF.	Turn the ice maker power switch ON
	The voltage of the power supply is low.	Add manostat.
	Ice cube full sensor damage	Replace the Ice cube full sensor
	The ice storage bin is full of ice.	Remove some ice; make sure the ice-full sensor is free of ice.
The water doesn't feed in after the ice maker starts.	The water supply tap is turned off.	Turn on the water supply tap.
	Water supply pressure is lower.	Adjust the water supply pressure within the range of stated range.
	Water inlet valve damage	Replace the water inlet valve.
	The water supply pipe is not properly connected.	Reconnect the water supply pipe.
Machine makes ice, but bin does not fill up with ice	The bin should fill up and the machine shut off in 9-14 hours. If not, the condenser may be dirty.	Clean the condenser.
	The bin drain may be partially restricted.	Clean out the drain, check the installation.
	The airflow to the ice maker may be obstructed.	Check the installation.
	Hot gas valve performance poor, lead to few ice is produced.	Replace the hot gas valve
	The sprinkler partially clogged, lead to few ice is produced.	Clean the sprinkler, see the user's manual "interior cleaning"
	Spraying of the small nozzle blocked by the ice slideway	Adjust the location of the ice slideway.
	The water quality is too poor. The water line blocks,lead to sprinkler pressure of spray isn't enough.	Using a filter apparatus installed in front of the water inlet valve.
	The ambient temperature and water temperature are high, or machine is near some heat source.	Check the installation.

Water is leaking from the unit.	A few water drops fall to the floor when you open the door to take out ice from ice storage bin.	Normal condensation on the door or some water together with ice. Take care when you take out ice.
	Water supply connection leaking.	Tighten fitting. See “Connecting the Water Line”.
	Nut of the water drain hole leaking.	Tighten the nut.
	Drainpipe connection leaking.	Tighten fitting. See “Connecting the Drain”.
The body of the ice maker is electrified.	The grounding line isn't in the socket.	Use the socket meeting the required electrical standard.
	The lines are creepage.	Adjust, reconnect /replace lines
Scales occur frequently inside the machine.	The hardness of the water is too high.	Use a water-softening device installed in front of the water inlet valve.
The ice cubes are incomplete when being dumped.	The sprinkler is blocked.	Clean it; see "Interior Cleaning".
Cubes are partially formed or are white at the bottom.	Not enough water in the water bin.	Check if the water supply pressure is below 14.5psi (0.1MPa).
		Check water supply--filter may be restricted.
		Check for a water leak at the water bin.
		Check if water inlet valve is restricted.
	The sprinkler is partially blocked.	Clean it; see "Interior Cleaning".
The sprinkler pressure of spray isn't enough.	Check.the water quality The water line may be blocked	
Noise during operation	The feet are not leveled and locked	Level and lock the feet. See “Leveling the Ice Maker”.
	Certain sounds are normal.	See “Normal Sounds”.
The downcomer doesn't leak.	The water line blocks	Clean it, see user and care manual "ice making system cleaning"
Harvesting ice is difficult	The water supply tap is turn off.	Turn on the water supply tap.
	The ambient temperature and water temperature is too low	Adjust the temperature.
The power indicated lamp is light,but the machine don't operate	The fuse is blown.	Replace fuse.
	The ice storage bin is full of ice.	Take away some ice cubes, make the ice-full sensor is free of ice.

The ice maker stops suddenly while making ice.	The electricity is off.	Reconnect the power supply line.
	The room temperature is out of the stated range.	Cut off the electricity; let the ice maker stop working till the temperature returns within the stated range.
	The fuse is brown.	Replace fuse.
	The voltage of the power supply is low.	Add manostat.
	The ventilation louvers are covered.	Remove the obstruction.
Cubes are too big.	The ambient temperature and water temperature is too low.	Adjust the temperature.