

Automatic Ice Maker

Service Manual

MIM-50, MIM50-O

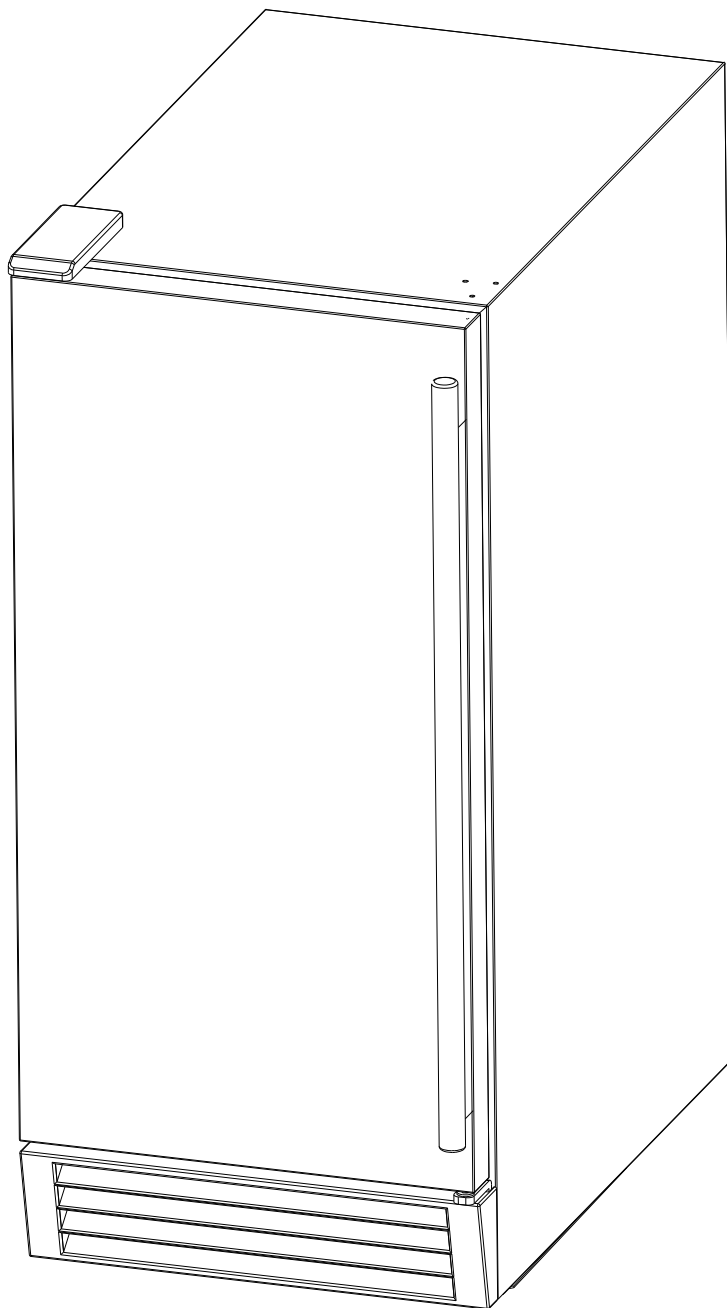

Table of contents

How the Icemaker works	3-10
Cooling System	3
Water System	4-5
Wiring Connections and Controller.....	6-8
Exploding Drawing	9-10
TroubleShooting	11-17
Before Maintenance.....	11
Basic Checking	11
TroubleshootingGuide.....	12-17
Adjustment and Replacement	18-19
Replace the controller.....	18
Replace the water pump.....	18
Replace the compressor.....	19
Replace the fan motor and fan blade.....	19
Replace the hot gas valve, drier and evaporator.....	19

IMPORTANT: The service manual is based on the user manual. Before servicing, please read user manual and service manual carefully. The service operation should be implemented by qualified technician.

How the Icemaker Works

Please refer to the section “**Operation** of user manual” from page 13 to 16 . It describes clear how the icemaker makes ice and uses the water.

There are 3 systems including Cooling System, Water System and Wiring Connection and Controller.

Cooling System

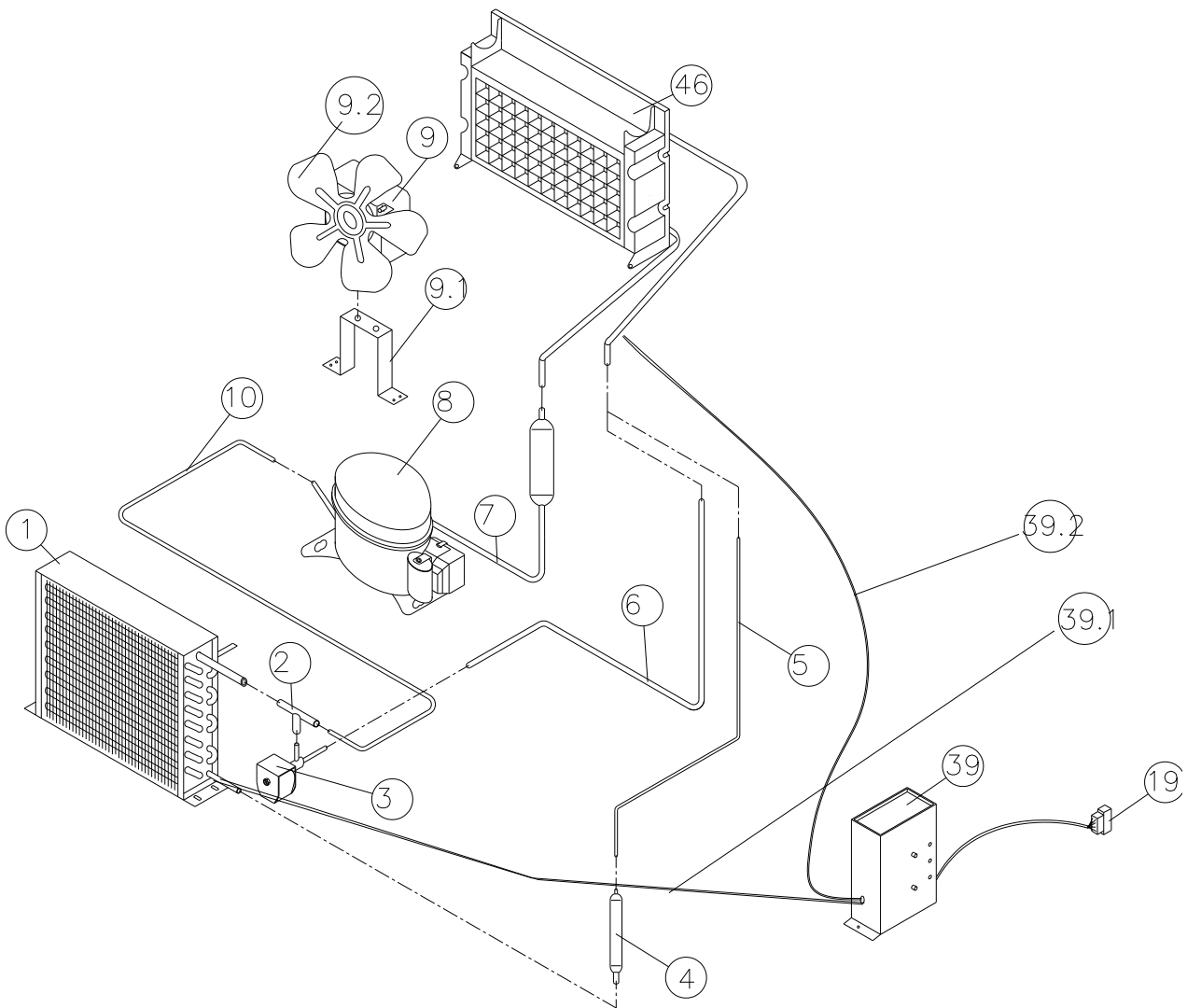

NUMBER	DESCRIPTION
1	Condenser
2	Multi-connection pipe
3	Hot gas solenoid valve
4	Drier & Filte
5	Capillary tube

6	Hot gas tube
7	Suction tube
8	Compressor
9	Fan motor
9.1	Fan motor support

9.2 Fan blade
10 Discharge tube
19 Wiring harness
39 Controllerbox

39.1 Temperature sensor of the condenser
39.2 Temperature sensor of the evaporator
46 Evaporator (Ice Mold)

During the ice-making stage, the hot gas solenoid valve is **closed**. The hot refrigerant gas is pumped out off compressor to condenser. The hot gas is cooled by fan forced air to warm liquid refrigerant after passing through the condenser. The drier & filter reduces the possible dirty and humidity in the refrigerant. The evaporator is cooled by the refrigerant. So ice can formed on the evaporator during water is sprayed to the evaporator. Low pressure refrigerant gas may go back compressor from the evaporator.

During the ice harvest stage, the solenoid valve is **open**. The hot refrigerant gas is pumped out off compressor to evaporator through hot gas valve. As the hot gas is not cooled by the condenser, the refrigerant makes the evaporator (ice mold) warm. So some ice touching the evaporator is thawed. All of ice can slide down to the ice storage bin.

Water System

When the water supply pipe is connected with the main water supply, water will fill the water trough through the floater valve till enough water inside water trough makes floater valve close. During ice-making stage, water is pumped from the water trough to the water distribution tube. The distributed water flow the surface of evaporator. Most parts of water go back water trough. Some water is frozen on the evaporator step by step. The floater valve will open and fresh water is recruited at any moment.

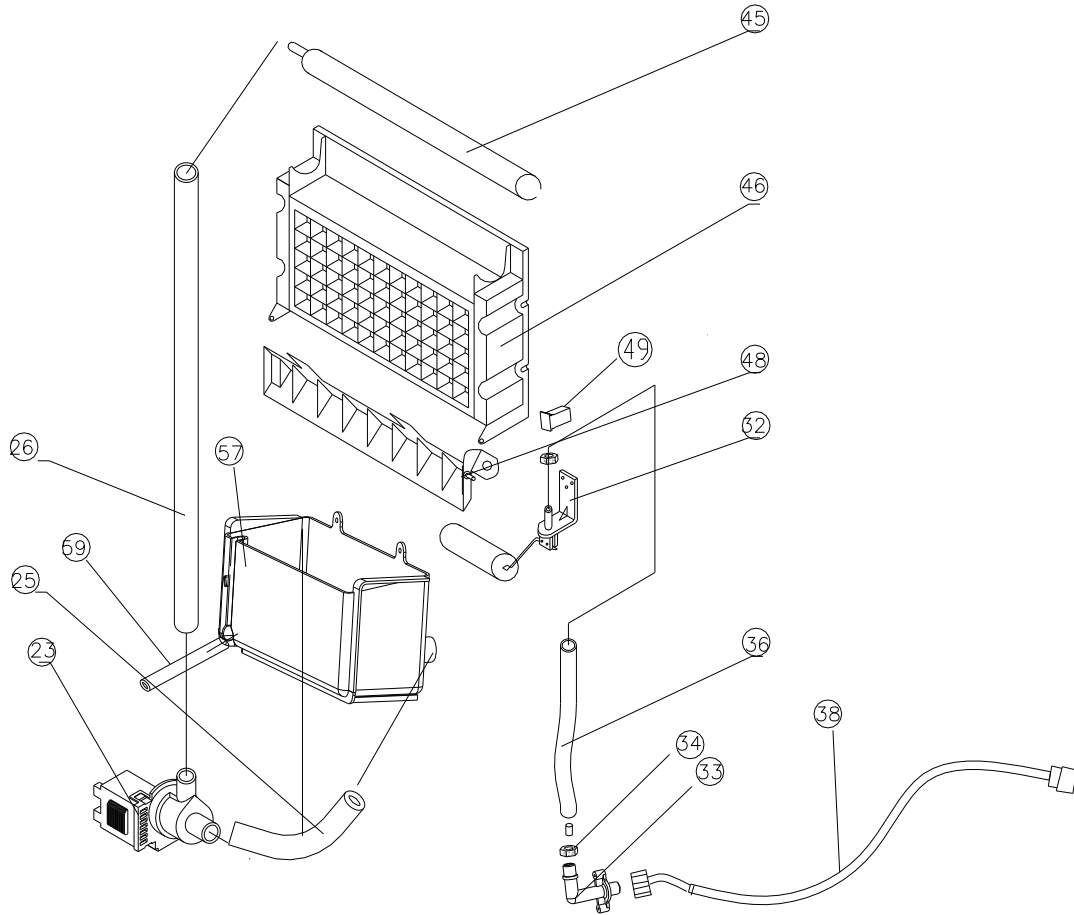

NUMBER DESCRIPTION

- 23 Water pump
- 26 Water pump outlet tube
- 33 Water inlet
- 36 Water inlet tube
- 45 Water distribution tube
- 48 Ice slideway
- 57 Water trough

NUMBER DESCRIPTION

- 25 Water pump inlet tube
- 32 Floater valve
- 34 Nut of water inlet tube
- 38 Water supply pipe
- 46 Evaporator
- 49 Ice full probe
- 59 Water trough drain tub

Wiring Connection :

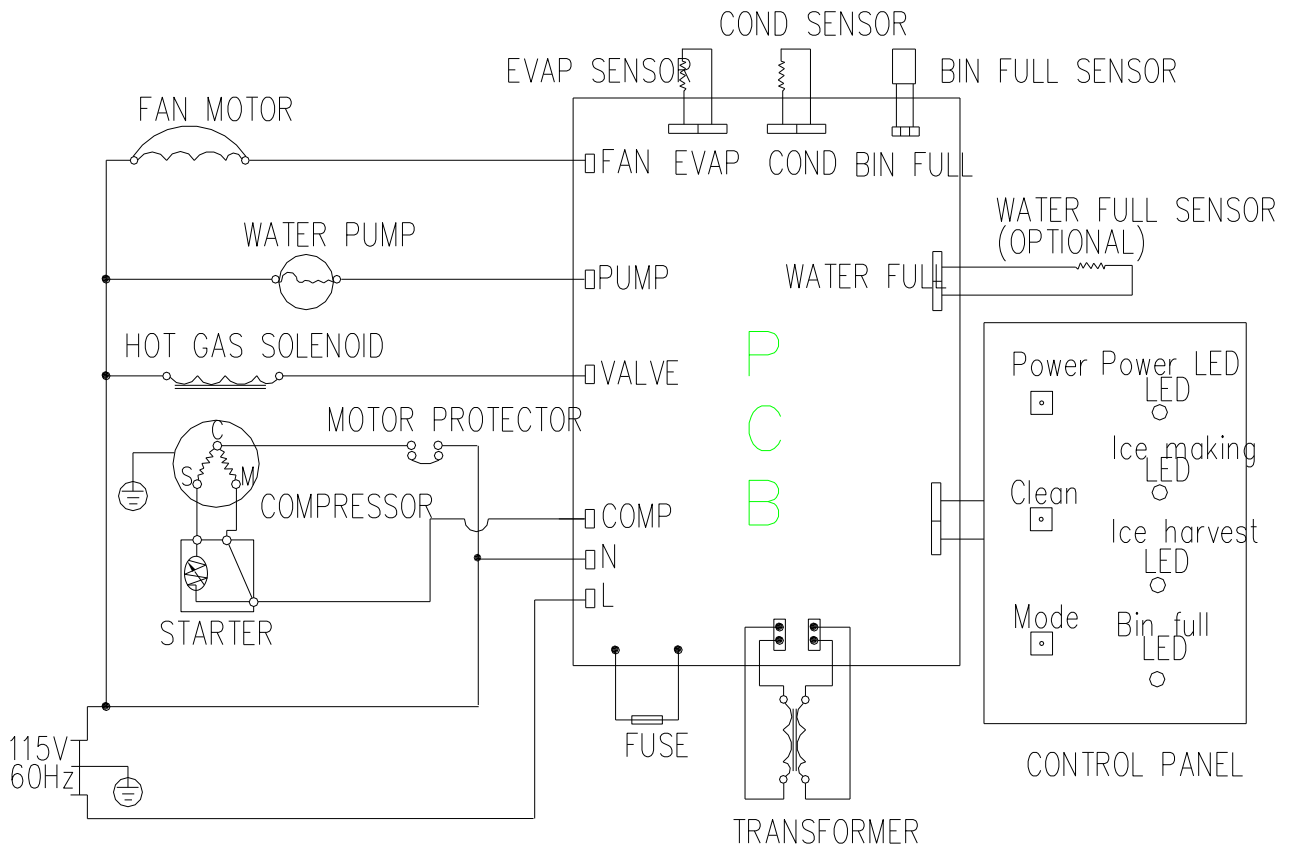

Circuit Description

1. Electrify Status For The First Time

As the icemaker is properly installed. switch on the water tap, let the water trough full (reach on the level), then turn the ICE/OFF/WASH switch to the ICE position on the front panel. The icemaker will start working automatically

In this status, the time is fixed about 3 minutes. This function is also helpful to protect the compressor avoiding restart within 3 minutes.

At this status, the **Red, Green, Yellow** LEDs are light together.

2. Ice-making Status

The compressor, motor fan and pump are powered on. The hot gas solenoid valve is powered off.

When this green LED is lit, the unit is working in the ice making mode controlled by a temperature probe on the evaporator. When the green LED is flashing, the unit is working in the ice making mode controlled by a fixed timer.

The fan motor is also controlled by a condenser sensor. When the ambient temperature is too lower, the motor fan stop working for good condensation to refrigerant.

3. Ice Harvest Status

The pump is powered off. The hot gas solenoid valve, compressor and motor fan is powered on.

The fan motor is also controlled by a condenser sensor. When the ambient temperature is too lower, the motor fan stop working for good condensation to refrigerant.

The Yellow LED indicates the ice harvest status.

4. Ice Full Status And Cold Preservation Stage

If the ice bin is fulfilled with ice or the full sensor is covered, the machine stops making ice and turn to cold preservation stage automatically.

In this status, the compressor works regularly to keep the lower temperature for lower ice melting. The rest of the electric components are powered off. The RED LED indicates the ice full status and the GREEN AND YELLOW LED together indicates the cold preservation status .

Controller box:

Instructions for LEDs and buttons:

1. Red LED: Ice full indicator light.

When this LED is lit, the ice storage bin is full of ice or there is something between the ice-full sensor in the ice storage bin. The unit will stop making ice. When ice cubes are taken out of the ice storage bin making the ice-full probe free, the red LED will keep flashing for 3 minutes. Then the unit will restart and return to the ice making mode.

2. Green LED: Ice making indicator light.

When this LED is lit, the unit is working in the ice making mode controlled by a temperature probe on the evaporator. When the green LED is flashing, the unit is working in the ice making mode controlled by a fixed timer.

3. Yellow LED: Ice harvest indicator light.

When this LED is lit, the unit is working in the ice harvest mode controlled by ice-full probe .

When green LED and yellow LED is lit, it means the unit is working in the cold preservation stage .

4. Mode button:

Mainly for service. When this button is pressed, it can change from ice making mode to ice harvest mode, or from ice harvest mode to ice making mode. You can judge the mode from the status of the green and yellow LEDs.

Ice Size Adjustment Guide:

1. Press and hold the “**Clean**” button and the “**Mode**” button together for at least 3 seconds. The unit will enter the Ice Size Adjustment mode. The “**HARVEST**” LED (yellow) will be blinking continuously during the ice size adjustment.
2. While in the Ice Size Adjustment mode, press the “**Clean**” button or the “**Mode**” button for the desired ice size.

Smaller ice setting:

By pressing the “Clean” button, you can decrease the size of the ice cubes. The “ICE” LED (green) will flash as you lower the ice size and will finally be blinking at the setting of smallest ice size.

Larger ice setting:

By pressing the “Mode” button, you can increase the size of the ice cubes. The “BIN FULL” LED (red) will flash as the larger size is set and will blink when the setting of largest ice size has been reached.

After 10 seconds without any operation, the unit will return to the previous mode.

NOTE: During the ice size adjustment, the “BIN FULL”, “ICE” and “HARVEST” LEDS blinking all at once indicate that the unit is in the default factory setting of the ice size.

MAJOR FUNCTIONS

1. The operating procedure is completely automatic.
2. When the ice storage bin is full of ice cubes, the machine stops making ice and proceeds to the cold preservation stage automatically. It starts making ice again after ice cubes are removed.
3. The different colors of the LED display indicate various work modes.
4. The fan motor responds to the ambient temperature. If it is cold, the motor will stop working to keep the cooling system in good working condition.
5. A sensitive probe and accurate timer enhance the performance of the ice maker.
6. A compressor protection system is built in.

Exploding Drawing

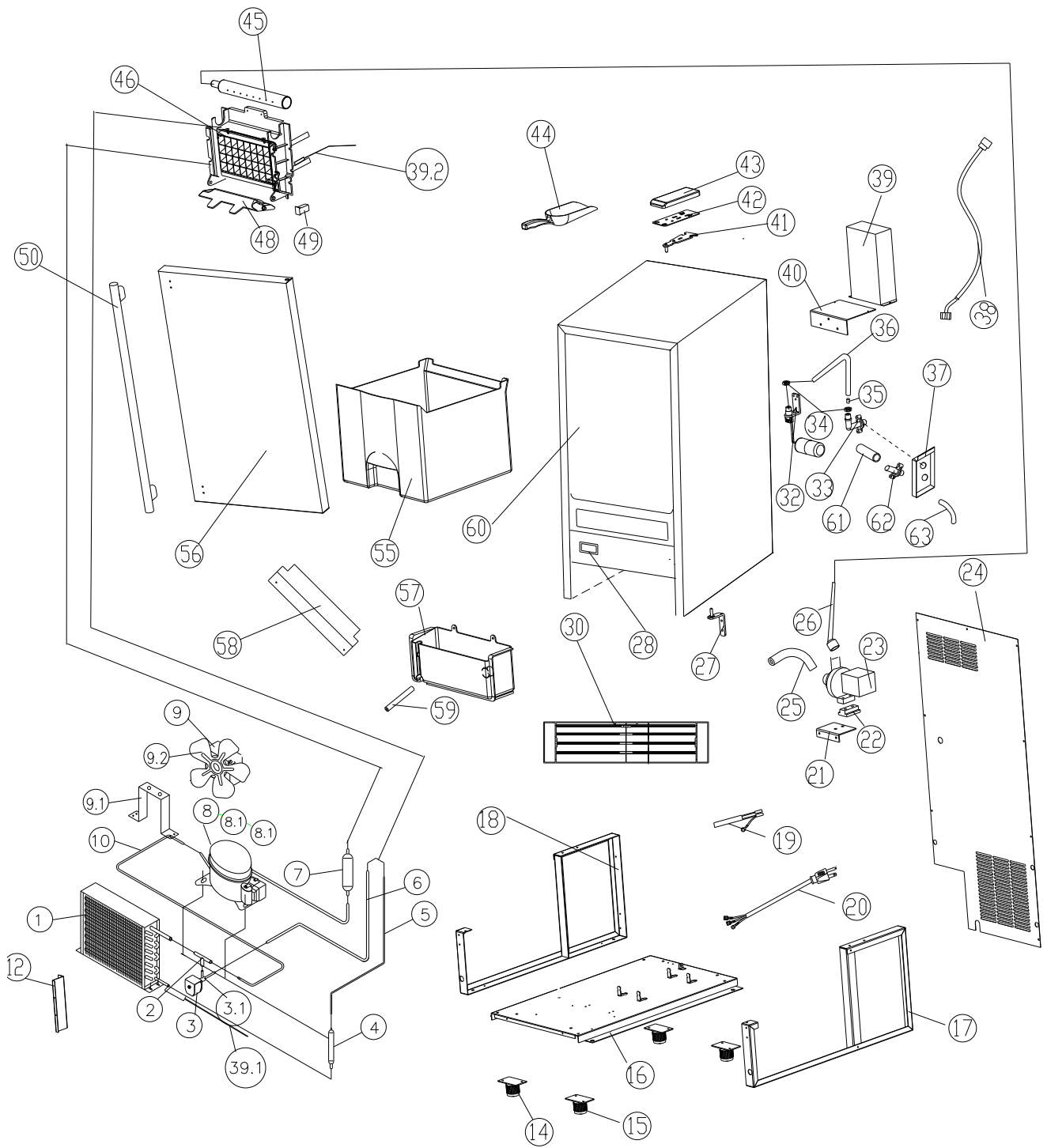

Item No.	Part Number	Description
1	1885000202	Condenser
3	1854703321	Hot gas valve coil (Zhongbao)
3.1	1854703310	Hot gas valve body (Zhongbao)
4	1880007500	Drier
8	1858421900	Compressor
8.1	1858460900	Starting relay
8.2	1858451100	Protector
9	1858200601	Fan motor
9.2	549738100	Fan blade (ϕ 200X28°)
14	1880014701	Left foot
15	1880014801	Right foot
19	1853703503	Wiring harness
20	1853113800	Power cord
23	1858900600	Water pump
30	1845744001	Louver
32	1880001701	Floater valve
33	1864526301	Water inlet
34	1864529100	Nut of the water inlet tube
38	1811306020	Water supply pipe
39	1854205801	Control box
39.1	1851700401	Temperature sensor of condenser
39.2	1851700501	Temperature sensor of evaporator
39.3	1854800500	Fuse
43	1864400101	Top hinge cover
44	1864800100	Ice scoop
45	1880001601	Water distribution tube
46	1880017702	Evaporator(Ice Mold)
48	1861701601	Ice slideway
49	1854005700	Ice full sensor
55	1864805201	Ice storage bin
63	1811306015	Drain pipe

Troubleshooting

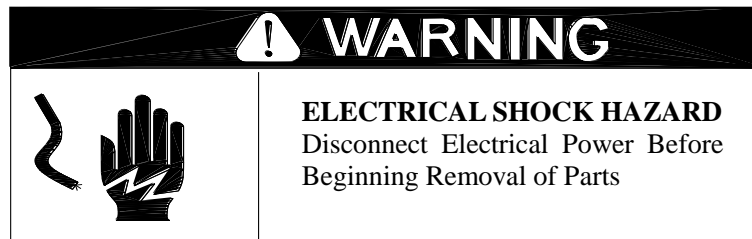

Before Maintenance

1. Check out the user if the user uses a 115 VAC, 60Hz. only 15ampere electrical supply, and have properly grounded, ensure the maintainer against electrical shock.
2. Check out the leads loose? Turn off? Short circuit? If have such problems, foreclose in turn.

Basic Checking

The icemaker has some trouble, through the appearance phenomena judges. So the service technician must check it thoroughly, then maintain.

Hearing

- Hearing the user 's depiction about the icemaker at using process and the phenomena. Try to understand what is the defect and how did the user operate the icemaker before calling for service.
- If the running sound is normal?

Looking

- Check the pipe of cooling system, especially the welding point. If there is some oil, the gas is leak out so that no ice making or less ice produced.
- If the cycle of the ice making and harvest is normal?
- Check the water system, especially the connection. If there is some water leakage.
- Check if the water filter needs to be replaced.
- Check if the icemaker installed according to the user manual.
- Check if the icemaker needs to be cleaned.

Touching

- Touch the hot gas pipe (with the evaporation weld), feeling the temperature. At the ice making stage, feeling cool. At the ice harvest stage, feeling hot.
- Touch the capillary tube (the drier nearby), feeling tepefaction.

Troubleshooting Guide

This troubleshooting guide in the user manual should be read before this guide. Be sure only when the trouble shooting in user manual can't help you solve the problem, turn to this guide.

Troubleshooting Guide

.The machine does not make ice

Problem kinds	Check part or point	Possible Cause	Probable Correction
The machine don't operate	Plug	The icemaker is unplugged.	Plug the icemaker in.
	Socket	Socket is damaged	Check and replace
	Power switch	The icemaker power switch turns to OFF.	Turn the icemaker power switch to ICE.
	Fuse	The fuse is blown.	Replace fuse.
	Wiring connection	Some wiring connection is incorrect or loosed	Check and re-connect
	Voltage	The voltage of the power supply is low.	Add manostat.
	Ice full probe	The ice full probe is out of function.	Replace a new one.
	Ice full probe	The ice full probe is covered by something	Clear the probe and make the ice-full probe is free.
	wiring	Some wiring is damaged	Replace a new one
	Electric component	Some electric component fail	Find the controller, press the mode button to change the mode. It is helpful to judge which part is out of function
	Controller	The controller fail	Replace a new one
Water System	Water supply tap	The water supply tap is turn off.	Turn on the water supply tap.
	Water supply pipe	The water supply pipe is not proper connected or maybe kinked	Reconnect the water supply pipe.
	Water line	Some water line leaks.	Plug into again.
		The water line blocks	Clean it, see user and care manual "ice making system cleaning"
		Water supply pressure is lower.	Adjust the water supply pressure within the range of stated range.
	Water inlet	Water inlet blocks	Check and clear it
	Water pump	Water pump damages	Replace water pump.
		The room temperature is out the stated range, the water pump stop automatically.	Make the temperature returns within the stated range.
		The lines of the water pump loose.	Plug into again
		The housing of water pump leaks.	Replace water pump.

	Drainage tray on top of the compressor	Drainage tray on top of the compressor is full	Drain off water by unscrewing lower drainage nut.
--	--	--	---

Problem kinds	Check part or point	Possible Cause	Probable Correction
The compressor doesn't start or start frequency	Wiring connects	loose.	Plug tightly, or replace.
	The start relay/thermal protect	Be damaged.	Replace the start relay/thermal protect of the compressor
	The startup coil / running coil	Be turnoff.	Replace the compressor.
		The motor of the compressor is short circuit.	Replace the compressor.
	Condenser	The condenser may be dirty.	Clean the condenser.
	Fan	The fan may be dirty or damaged	Clean or Replace the fan .
	The Electronic controller	The controller is damaged	Replace the Electronic controller.
The compressor run but no ice	Refrigerant	Refrigerant leaks completely	Add low side access valve, locate leak, recover refrigerant, replace drier, evacuate and weigh in the data plate charge.
	Capillary tube	Capillary tube is blocked	Add low side access valve, recover refrigerant, replace hot gas valve, replace drier, evacuate and weigh in the nameplate charge.
	Vent	The vent is obstructed around the ice machine	Clean the vent
	Hot gas valve	Hot gas valve damaged	Replace
	The Electronic controller	The model of making ice doesn't turn to harvest.	Replace the Electronic controller.
		Tthe unit is working in the cold preservation stage mode controlled.	Work in normal mode

2.Low production

Problem kinds	Check part or point	Possible Cause	Probable Correction
Cooling System	Refrigerant	Refrigerant leaks partially	Recharge.
	Condenser	The condenser may be dirty.	Clean the condenser.
	The ambient temperature	The ambient temperature is high or too low	Check the ambient and air flow
	Fan	The fan is dirty or damaged	Clean or replace
	Hot gas valve	Hot gas valve performance poor, leads to few ice is produced.	Replace the hot gas valve
	Electronic controller	The setting of temperature of Electronic controller is low.	See the service manual "adjust the size of ice cubes"
	Sensor	The sensor of temperature damages	Replace the sensor of temperature.
Water System	Water distribution tube	The water distribution tube blocks	Clean the water distribution tube
	Water line	The water quality is too poor. The water line blocks	Using a filter apparatus installed in front of the water inlet valve.
	Silica gel tubes	The silica gel tubes distort, lead to block.	Make the silica gel tubes resile
	Floater valve	The floater valve leaks. Lead to few ice produced.	Repair or replace
	Wheel	The icemaker is not proper leveled.	See installation

3.Ice Cube is not OK

Problem kinds	Check part or point	Possible Cause	Probable Correction
	Condenser	The condenser is dirty or the air grills are covered	Clean the condenser. Leave space around the machine

Cubes are too small	The ambient temperature	The ambient temperature is too high.	Adjust the ambient temperature.
	Electronic controller	The setting temperature is high.	See the service manual "adjust the size of ice cubes"
	Refrigerant	Refrigerant leaks	Recharge.
Cubes are too big	Electronic controller	The setting temperature of Electronic controller is low.	See the service manual "adjust the size of ice cubes"
	Sensor	Temperature sensor of the evaporator damages	Replace the sensor of temperature.
	The ambient and water temperature	The ambient temperature and water temperature is too low.	Adjust the temperature.
The cubes are partially formed--have ragged sides	Water quality	The water quality is poor	Using a water-soften / filter apparatus installed in front of the water inlet valve.
	Evaporator	Ice machine is dirty	Clean and sanitize the ice machine
	Water distribution tube	The water distribution tube blocks partially	Clean the water distribution tube
	The room temperature	The room temperature is out the stated range, the water pump stop	Make the temperature returns within the stated range.
The ice cubes shape deformity	Filter	Water filtration element needs to be changed	Replace the filter
	Water trough	Water trough level is too low	Adjust the water floater
Cubes are partially formed—are white at the bottom	The room temperature	The room temperature is out the stated range, the water pump stop automatically.	Make the temperature returns within the stated range.
	Water trough	Water trough level is too low	Adjust the water floater

4.Other problems

Problem kinds	Check part or point	Possible Cause	Probable Correction
The body is electrified	Earth line	The earth line isn't in the socket.	Please use the socket meeting the standard.
	Lines	The lines are creepage.	Adjust, reconnect /replace lines
	Electric component	The electric component is creepage,	Replace this electric component.
Scales occur frequently inside the machine	the water quality	The rigidity of the water quality is too high.	Using a water-soften apparatus installed in front of the water inlet.
Noise during operation is big	Spring of the internal compressor	The spring of the internal compressor drops.	Replace the compressor.
	Water pump	The noise of the water pump	Replace the water pump.
	Pipeline system	Pipeline system resonate	Clear pipeline system
	Feet	The feet are not leveled	Level and lock the feet.
	Fan motor	The fan motor loose, the clearance of the rotor is bigger, the fan blade turns back	Relocate the fan motor / replace
Problem kinds	Check part or point	Possible Cause	Probable Correction
Water is leaking out the unit	The operation	A few water drops to the floor when you open the door to take out ice from ice storage bin.	Normal condensation on the door or some water together with ice. Take care when you take out ice.
	Water supply connection	Water supply connection leaking.	Tighten fitting.
	Drainage tray on top of the compressor	Water full probe is out of function	Replace the new one.
	Water line	Some water line leaks.	Plug into again.
The water distributio	Lines of the water pump	The lines of the water pump loose.	Plug into again
	Water pump	Water pump damages	Replace water pump.
	Water distribution tube	The water distribution tube blocks	Clean the water distribution tube

n tube doesn't spray	Ice full probe	The ice full probe is broken or can not turn back normal position.	Repair or replace the probe
	The room temperature	The room temperature is out the stated range, the water pump stop	Make the temperature returns within the stated range.
Harvesting ice is difficult	Hot gas valve	The hot gas valve is poor,	Replace the hot gas valve
		The hot gas valve damage	Replace the hot gas valve
	Ice mold of the evaporator	The ice mold is dirty, or polishing degree is poor.	Clean the ice mold, or replace the evaporator.
	Refrigerant	Refrigerant leaks	Recharge
	Ice machine	Ice machine is not proper leveled	Level the ice machine
	The ambient and water temperature	The ambient and water temperature is too low	Adjust the temperature.
	Ice cubes size	The size is too big.	See “the adjust of ice cube size”.
The evaporator is hot more than 4 minutes	Hot gas valve	The lines of the hot gas valve loose.	Plug into again
		Hot gas valve performance poor or break	Replace the coil of hot gas valve if only because of the coil.
	Refrigerant	Refrigerant leaks	Recharge
The icemaker make an alarm sound regularly	The drainage tray on top of the compressor	The electric controller is wrong	Check the controller
		The drainage tray on top of the compressor is full.	Drain off water by unscrewing lower the drainage nut.

Adjustment and Replacement

Replace Controller, fuse and the sensor of temperature

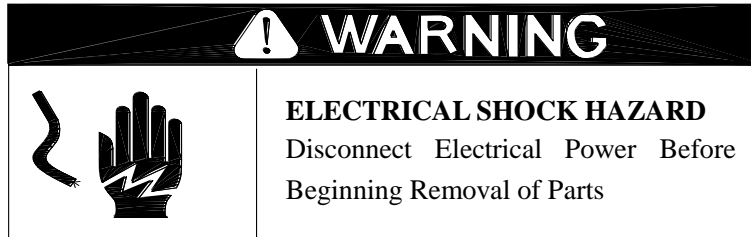

- Remove the rear cover, front panel,
- Locate the Electronic controller,
- Pull out the sensors of temperature (one at the evaporator, another at the condenser).
- loosen the screws of rooting the Electronic controller, replace a new one. Reverse the above step to replace.
- If you need replace the fuse, open the front panel of the control box, you will find the figure.

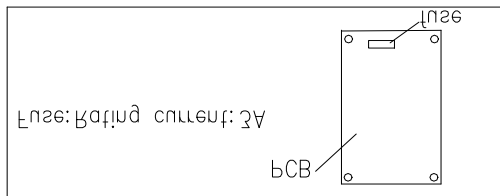

According the figure, take out the fuse, replace a new one.

Reverse the above step to reassemble.

- If you need replace the sensors of temperature, pull out the sensor of temperature, open the panel of the controller box, pull out the other side, replace a new one. Reverse the above step to reassemble.

ADVICE

Expert advises the cube size have been adjusted ok before leave factory, had better not adjust it.

Replace the water system components

Please see the water system drawing. The water leakage should be checked after this kind of operation

NOTICE

Before replace the water system components, it will be necessary to drain the system of water.

1. Replace the water pump

- Disconnect electrical power.
- Remove the rear cover.
- Unplug the lines connector with the water pump, the water outlet tube of pump and the water

inlet tube of pump.

- Loosen the screws, replace a new one.
- Reverse the above step to reassemble.

Replace the cooling system components

Replace the condensing components, See Figure “cooling system”

1. Replace the compressor and the compressor kit (includes relay, thermal protect).



- If only need replace the compressor kit, remove the rear, locate the compressor, take the clip, open the cover, replace the wrong,
- Reverse the above step to reassemble.
- If need replace the compressor, remove the rear cover, and cabinet, locate the compressor.
- Unplug the lines and taken out the earth line, add low side access valve, open the Process/Suction, evacuate refrigerant, take out the compressor, replace a new one, joint together, then recover refrigerant, weigh in the nameplate charge.
- Reverse the above step to reassemble.

2. Replace the fan motor and fan blade.

- Remove the front panel, rear and cabinet.
- locate the fan motor, unplug the lines connecting with the fan motor, loosen the screws of holding fan motor bracket.
- Replace a new one, If only need replace the fan blade, loosen the screws holding the fan blade, taken out the damaged, replace a new one.
- Reverse the above step to reassemble.

3. Replace the hot gas valve, drier and evaporator.

- Remove the rear cover.
- Locate the drier and hot gas valve, add low side access valve, recover refrigerant, replace the drier and hot gas valve, evacuate and weigh in the nameplate charge.
- Reverse the above step to reassemble.
- If need replace the evaporator.
- Remove the rear, locate the evaporator, add low side access valve, open the process/suction, weld open the two welds, replace a new one. Recover refrigerant, evacuate and weigh in the nameplate charge.
- Reverse the above step to reassemble.