

# HEATED DISPLAY CABINET

MARSHALL  
OWNER'S  
MANUAL

MODEL QQ5

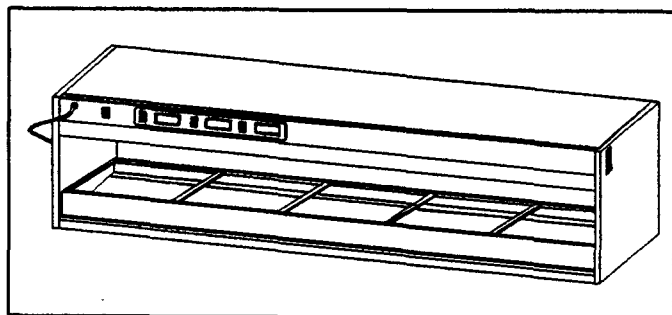

**MODEL: QQ5**

Supplier Name: **MARSHALL AIR SYSTEMS, INC.**  
Address: **419 Peachtree Drive South  
Charlotte, NC 28217**

Model #: **QQ5**  
Serial #: \_\_\_\_\_  
Date Received: \_\_\_\_\_  
Date Installed: \_\_\_\_\_  
Telephone #: **704-525-6230**  
Toll Free #: **800-722-3474 Customer Service**  
Fax #: **704-525-6229**  
Service Referral #: **800-722-3474**  
Local Service Name: \_\_\_\_\_  
Local Service #: \_\_\_\_\_

## GENERAL SPECIFICATIONS

Model #:	QQ5
Height:	16-1/4"
Width:	66-1/2"
Depth:	21"
Electrical:	110/120 volts 17 amps
Weight:	180 lbs.
Qty of 40	
Watt Lights:	Eight
Power Cord:	8 ft. 3 wire grounding type UL rating
Approvals:	UL and NSF

## MANUFACTURER'S INTRODUCTION

This Heated Display Cabinet features Marshall's own ThermoGlo® heating technology. Heat radiates from every square inch of the upper flat plate heating surface. This eliminates the need to clean intricate calrod, wire and reflector assemblies. A precision microprocessor-type digital display and digital "set point" temperature controller maintain consistent product temperatures.

## INSTALLATION

1. Unpack unit and remove all protective paper or plastic covering from metal parts.
2. Place cabinet on stable base. Make sure cooling air inlets, on sides of unit, are not blocked.
3. The unit should be caulked to the counter top as required by health department codes.
4. Install 40 watt plastic coated lights which were shipped loose.
5. Plug unit into an AC 120V receptacle.

## CHECKLIST AND CLEANING GUIDE DAILY

### OPENING CHECKLIST

1. Turn on the power switch. This will light the displays on the temperature controllers and turn on the lights. The switches next to each controller will turn on the heater for that temperature controller. The unit is ready to use after a 30 minute preheat period.
2. The temperature controller on the unit is factory set for 450°F. With the control "ON", the actual temperature is displayed. The face plate of the control is either black or gray. The set point may be verified or changed as follows:  
  
**IF BLACK:** depress the set button to view the set point. To change set point, use Up/Down arrow to select new set point while holding set button down.  
  
**IF GRAY:** depress the set button and RELEASE to view set point. To change set point, push "set" and, within three seconds, use Up/Down arrow to select new set point.  
  
**CAUTION: PRESS ONLY WITH SOFT PART OF FINGER -- DO NOT PUSH WITH SHARP OBJECT.**
3. In normal operation, the digital controller will display a value of approximately 480°F high to 430°F low.

### CLOSING CHECKLIST

1. Turn off the unit and allow it to cool for 20 minutes.
2. Pans and wire grates should be removed, washed in mild multi-purpose detergent, rinsed and sanitized.
3. Clean unit and base with a damp cloth or non-abrasive cleaner. **DO NOT IMMERSE UNIT IN WATER! DO NOT USE CAUSTIC CLEANING SOLUTIONS!**
4. Allow sufficient drying time before attempting to use.

## **PREVENTIVE MAINTENANCE**

Follow the daily schedule; there are no adjustments. The only user-replacement items are the light bulbs located under the top cover. If these fail, do the following:

1. Unplug the unit.
2. Remove the bulb(s) by carefully unscrewing them from their sockets.
3. Replace the bulb(s) with a manufacturer's approved replacement part. (See parts list page 4.)
4. Check air flow through unit by feeling for air draw at slots on the sides of the cabinet.

## **TROUBLE SHOOTING CHART**

Identify problem in the left column and look for probable cause and solution in right hand column. Probable causes listed in the order they are most likely to happen. This sequence should be used to isolate the problem.

<b>Problem</b>	<b>Probable Cause</b>	<b>Solution</b>
1. No Light/No Heat	Unplugged Circuit breaker is tripped  Cord/plug defective	Plug in Reset breaker - call electrician if tripped twice Call Marshall Customer Service
2. No Light/With Heat	Light bulbs burned out Wire to bulbs disconnected	Unplug unit and replace bulbs Call Marshall Customer Service
3. Temperature Controller Flashing 999	*Defective temperature controller or sensor	Call Marshall Customer Service
4. Temperature Controller Displays Less Than 450 °F	* Loose sensor or defective heating unit assembly	Call Marshall Customer Service
5. Low Product Temperature	Set point too low Excessive air draft	Reset to 450 °F Move unit or shield draft

\* NOTE: when replacing sensor, a special heat sink sealant will be present when removing failed sensor. Applying new sealant is not required; however, be sure to utilize existing sealant when mounting new sensor.

ITEM	PART NO.	DESCRIPTION	ITEM	PART NO.	DESCRIPTION
1	114579	Cord with Plug	12	110915	ThermoGlo 10" X 14"
2	502080	Strain Relief	13	113597	Sensor Guard ThermoGlo 10" X 14
3	501864	Switch Rocker	14	111975	Side Panel
4	110042	Fan	15	112634	Doors-Plexiglass
5	500294	Terminal Block - 6 Pole	16	501484	Screw #10 X .500"
6	113572	ThermoGlo 20" X 14"	17	501507	Screw #10-24 X .500"
7	114544	Temperature Controller RTD	18	113570	Divider Bar .750" Middle
8	502239	Bulb Tuffskin 40 Watt	19	113577	Divider Bar .500" End
9	501865	Lamp Holder	20	502115	Transformer 120V-12V
10	113571	Sensor Guard ThermoGlo 20" X 14"	21	113566	Top Door Guide Assembly
11	502064	Sensor RTD	22	113567	Bottom Door Guide Assembly
				503413	Kit, Temp Control Faceplate DEC F Ref: 132574

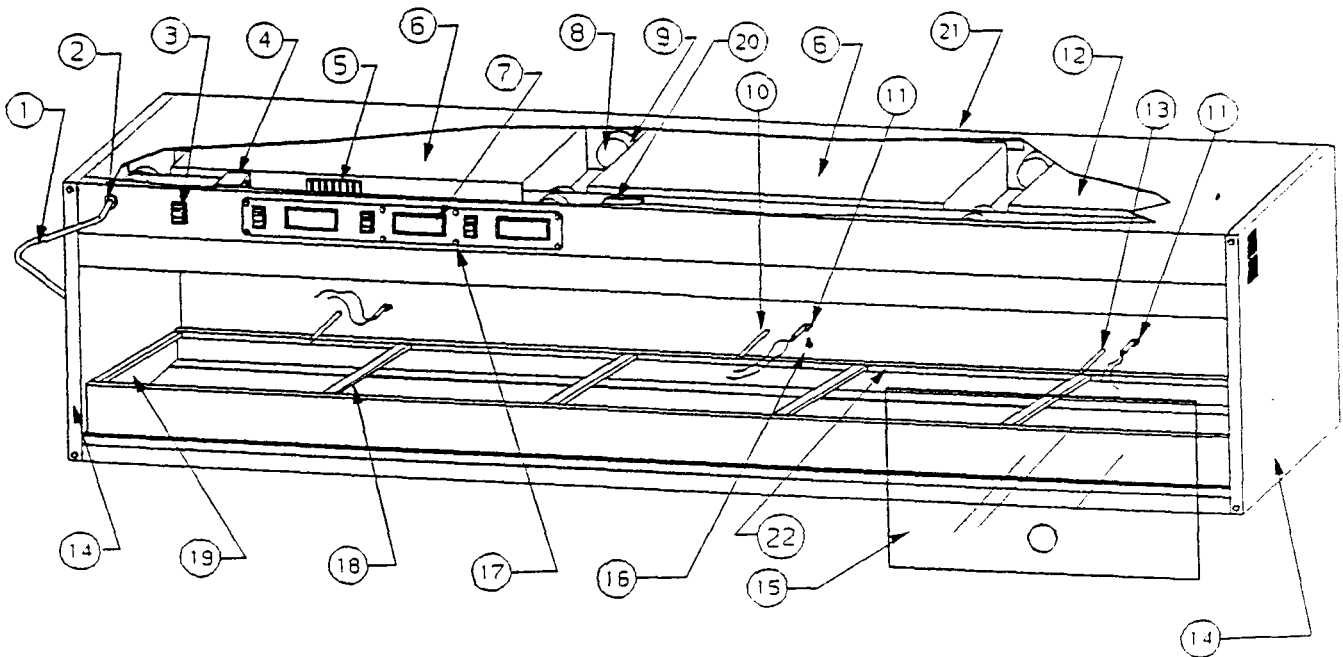

# HEATED HOLDING CABINET LIMITED WARRANTY

MARSHALL AIR SYSTEMS, INC., ("Marshall") warrants to the first purchaser ("Purchaser") all new equipment of its manufacture to be free of defects in material and factory workmanship for a period of one year from date of shipment provided that (i) the equipment is installed in the Continental United States, Canada or Hawaii and operated according to the Owner's Manual while located at the original address of installation, (ii) the warranty registration card has been completed and returned to the factory within fifteen (15) days after installation, and (iii) a post-installation start-up has been performed by an authorized service representative (portable equipment not applicable). Marshall's obligation under this warranty is limited to the repair or replacement at its option of any defective part. Under certain circumstances, Marshall will reimburse Purchaser for limited labor costs in replacing parts during a period of not more than ninety (90) days from date of shipment, provided that Labor Reimbursement instructions are followed and items i, ii, and iii above are completed. See special provision for portable equipment. It is understood that Marshall's obligation with respect to equipment located outside the Continental United States, Canada or Hawaii is limited to replacement parts only.

Because Marshall does not and cannot control Purchaser's installation, use, and maintenance of equipment manufactured by Marshall, this warranty **DOES NOT COVER:**

Any equipment calibration;

Any component disassembled in the field;

Damage due to improper cleaning and/or abuse, i.e. burner rotation, grease accumulation in electrical components or plugs (hosing or "watering down" equipment will cause electrical failures not covered by warranty);

Blown fuses or bulbs, motor brushes, and Teflon components:

Any replacement parts used on the equipment which are not purchased from Marshall:

Accessory components not installed and/or manufactured by Marshall.

Shipping damage must be reported to the carrier and is not covered under this warranty. Marshall will not be liable for damage as a result of improper installation, misuse, abuse, alteration of original design, incorrect voltage, unauthorized service, breakage of fragile items, or any other damage caused by an act out of Marshall's control.

The effect of corrosion, fire, and normal wear on the equipment or component parts is not covered by this warranty. This warranty does not cover cooking performance, smoke capture or holding temperatures which is a function of food types, textures, temperatures, equipment line ups and other variables chosen by the Purchaser and over which Marshall has no control. This warranty does not apply to damage caused by accident or to damage caused by the negligence of Purchaser or the employees of Purchaser or to damage caused by lightning generated electrical current or any other Act of God whatsoever. This warranty does not apply to any equipment bearing a serial number which has been tampered with or altered. Marshall reserves the right to accept or reject any such claim in whole or in part. Marshall will not accept the return of any product without prior written approval from Marshall, and all such approved returns shall be made at Purchaser's sole expense.

**THIS WARRANTY IS IN LIEU OF ALL OTHER WARRANTIES, EXPRESS OR IMPLIED, INCLUDING THE IMPLIED WARRANTY OF MERCHANTABILITY AND THE IMPLIED WARRANTY OF FITNESS FOR A PARTICULAR PURPOSE, OR PATENT OR OTHER INTELLECTUAL PROPERTY RIGHT INFRINGEMENT, AND EXCEPT FOR THE EXPRESS WARRANTY CONTAINED HERE IN, THE EQUIPMENT IS SOLD "AS IS." REMEDIES UNDER THIS WARRANTY AND UNDER ANY WARRANTY THAT MAY SURVIVE THE DISCLAIMER OF WARRANTIES ARE LIMITED EXCLUSIVELY TO THOSE REMEDIES DESCRIBED ABOVE. NO OTHER REMEDY IS AVAILABLE UNDER THIS WARRANTY OR ANY OTHER WARRANTY. NEITHER THIS WARRANTY NOR ANY OTHER WARRANTY COVERS, AND MARSHALL WILL NOT BE RESPONSIBLE FOR, ANY INCIDENTAL OR CONSEQUENTIAL DAMAGES, INCLUDING BUT NOT LIMITED TO THE COST OF DISASSEMBLY AND SHIPMENT OF THE EQUIPMENT, PRODUCTION OR PRODUCT LOSSES, INJURY TO OTHER PROPERTY, OR LOST PROFITS RESULTING FROM THE USE OF OR INABILITY TO USE THE PRODUCTS OR FROM THE PRODUCTS BEING INCORPORATED IN OR BECOMING A COMPONENT OF ANY OTHER PRODUCT OR GOODS, OR OTHER LOSSES. WHERE, DUE TO OPERATION OF LAW, CONSEQUENTIAL AND INCIDENTAL DAMAGES CANNOT BE EXCLUDED, THEY ARE EXPRESSLY LIMITED IN AMOUNT TO THE PURCHASE PRICE OF THE EQUIPMENT.**

**FOR INTERNATIONAL INSTALLATIONS -- PLEASE CONTACT YOUR LOCAL MARSHALL AIR SYSTEMS RECOGNIZED DISTRIBUTOR.**

## HEATED HOLDING CABINET WARRANTY PROCEDURES

### RETURN GOODS AUTHORIZATION FOR PARTS - FACTORY DIRECT

For prompt warranty parts replacement and RGA processing, please call Marshall's Customer Service Department at 800-722-3474 or 704-525-6230 for assistance. In all cases, a Return Goods Authorization (RGA) number must be issued by Marshall Air Systems, Inc. Unauthorized returns will not be processed.

Option #1: Purchaser to return part prepaid to Factory, Marshall to repair or replace at own expense if defective, and ship part back to Purchaser prepaid.

Option #1: Marshall to furnish replacement part freight prepaid with or without requesting return of the defective part.

### WARRANTY LABOR REIMBURSEMENT AND/OR PARTS REPLACEMENT THROUGH RECOGNIZED SERVICE AGENCY

To be reimbursed for warranty labor costs, authorization must be given by Marshall Air Systems, Inc. Unauthorized work will not be reimbursed. Work must be performed by a Marshall Air Systems Recognized Service Agency within the service time allowance guidelines and must be submitted along with failed parts (if applicable) to Marshall Air Systems (freight prepaid) within 30 days of the work being performed. Travel is covered, but must not exceed 50 miles or 1 hour, whichever is greater. Call Marshall's Service Department at 800-722-3474 or 704-525-6230 with any questions. Service is to be performed by recognized service agencies during normal working hours. Owner to pay for all other charges including excessive travel or overtime charges. **DIAGNOSTIC LABOR CHARGES ARE INCLUDED IN SERVICE TIME ALLOWANCE GUIDELINES.** All portable equipment (under 90 pounds) shall be delivered by Purchaser, at his/her expense, to the nearest authorized service agency for in-shop repair or at Purchaser's discretion he/she will pay all travel time and mileage expenses for portable equipment.

### NON-WARRANTY RETURNS:

All items returned for customer convenience are subject to a 20% restocking fee. In the event of an error by Marshall Air Systems, Inc., a Returned Goods Authorization will be issued for full credit.

### FOR INTERNATIONAL INSTALLATIONS -- PLEASE CONTACT YOUR LOCAL MARSHALL AIR SYSTEMS RECOGNIZED DISTRIBUTOR.

REV	DATE	REVISION DESCRIPTION
1	11-MAR-82	GIVE CONTROLLER A SET-UP PART NUMBER.
2	17-MAR-82	CH. CORD FROM 12/3 TO 14/3.
3	06-JUL-82	CH. TO NEW CONTROLLER DESIGN (SET-UP FROM FRONT)
4	12-JAN-83	CH. TRANSFORMER FOR #502115 TO #502248 (120V-175V)
5	09-MAY-84	CH. BULBS TO 40 WATTS
6	10-OCT-84	TRANSFORMER 502115 WAS 502248
7	23-JAN-97	TYPE 500239 SHOULD BE 502239 (T51)

MARSHALL AIR SYSTEMS, INC.

**SCHEMATIC 005 120V, 17AMPS**

SIZE BY: J.R. Dwg. NO. 113754

SCALE NTS DATE: 09-SEP-91 CODE: 005

REV 7

