

# OWNER'S MANUAL

## MODEL HT18 HT10 AUTOTOAST™ HORIZONTAL TOASTER



**Model HT18 w/ Optional LED Control**

Supplier Name: **MARSHALL AIR SYSTEMS, INC**  
Address: 419 Peachtree Drive South  
Charlotte, NC 28217

Model #: \_\_\_\_\_  
Serial #: \_\_\_\_\_  
Date Received: \_\_\_\_\_  
Date Installed: \_\_\_\_\_  
Telephone #: 704-525-6230  
Fax #: 704-525-6229  
Service Referral # 800-722-3474  
Local Service: \_\_\_\_\_  
Local Service #: \_\_\_\_\_

### PRODUCT DESCRIPTION

The Model HT18 and HT10 Horizontal Toaster produces caramelized buns hot and fast for building sandwiches to customer orders. These models have a slim horizontal footprint. Buns are loaded at the top and released onto a product slide at the bottom. The variable speed drive ranges from 20 seconds to 2 minutes. Heat controls are fully adjustable from 200°-565°F with the LED Control. Left and right side toasting temperatures can be zoned for flexibility.

All controls are located inside a secured cabinet, eliminating unauthorized tampering. The toaster is adjustable for various crown and heel bread thickness. The multi-control feature options of this toaster produce and deliver the hottest buns in the shortest time.

The Model HT10 is 8" narrower.

### GENERAL SPECIFICATIONS

Model: HT18 HT10 Horizontal Toaster  
Height: 15.000"  
Width: HT18 - 25.000"  
HT10 - 17.000"  
Depth: 23.375"  
Options: LED Control  
Electrical: HT10 - 120VAC, 60Hz, 15A  
HT18 - 208-240 VAC, 60Hz,  
14-17A  
MM2BINTLDMK - 220V, 4 wire, 8A  
Power Cord: 6FT 3 wire ground type UL  
HT18 Domestic NEMA 6-20 Plug  
HT18 International No Plug  
HT10 120V NEMA 5-20 Plug  
HT10 208V NEMA 6-15 Plug  
Weight: HT18 - 115 lbs.  
HT10 - 95 lbs.  
Approvals: ETL/CETL, CSA, CE and NSF

# OWNER'S MANUAL

## MODEL HT18 HT10 AUTOTOAST™ HORIZONTAL TOASTER



### FOR YOUR SAFETY

DO NOT STORE OR USE GASOLINE OR OTHER  
FLAMMABLE VAPORS OR LIQUIDS IN THE  
VICINITY OF THIS OR ANY OTHER APPLIANCE

### **AVERTISSEMENT**

**Ne pas entreposer ni utiliser de l'essence ni d'autres vapeurs ou liquides inflammables dans le voisinage de cet appareil, ni de tout autre appareil.**

WARNING: IMPROPER INSTALLATION, ADJUSTMENT, ALTERATION, OR MAINTENANCE CAN CAUSE PROPERTY DAMAGE, INJURY OR DEATH. READ THE INSTALLATION, OPERATION AND MAINTENANCE INSTRUCTIONS THOROUGHLY BEFORE INSTALLING OR SERVICING THIS EQUIPMENT.

**AVERTISSEMENT: Une installation, un ajustement, une altération, un service ou un entretien non conforme aux normes peut causer des dommages à la propriété, des blessures ou la mort. Lisez attentivement les directives d'installation et d'opération et d'entretien avant de faire l'installation ou l'entretien de cet équipement**

**KEEP THIS MANUAL IN A SAFE PLACE AND RETAIN FOR FUTURE USE.**

**Toaster area must be kept free of combustible materials and the flow of ventilation air must not be obstructed. Operating personnel must not perform any maintenance or repair functions. Contact your Qualified Service Company.**

# OWNER'S MANUAL

## MODEL HT18 HT10 AUTOTOAST™ HORIZONTAL TOASTER



### TABLE OF CONTENTS

INSTALLATION .....	1-2
OPERATION (UNITS WITH STANDARD PUSH BUTTON) .....	2
OPERATION (UNITS WITH OPTIONAL 3 DIGIT CONTROL) .....	2
PREVENTIVE MAINTENANCE .....	3
TOASTER CONTROL DESIGNATION.....	4
TROUBLESHOOTING GUIDE .....	4-8
REPLACEMENT PARTS .....	9-10
CONTROL GENERATION 1 ELECTRICAL REPLACEMENT PARTS .....	11
CONTROL GENERATION 2 ELECTRICAL REPLACEMENT PARTS .....	12-13

### ILLUSTRATIONS

OVERALL DIMENSIONS (HT18) .....	FIGURE 1, 2
OVERALL DIMENSIONS (HT10) .....	FIGURE 1A,2A
HANG-ON PARTS (HT18).....	FIGURE 3
HANG-ON PARTS (HT10).....	FIGURE 3A
TOASTER PLATEN SHEET (HT18).....	FIGURE 4
TOASTER PLATEN SHEET (HT10).....	FIGURE 4A
CARRIAGE ASSEMBLY.....	FIGURE 5
DRIVE MOTOR ASSEMBLY .....	FIGURE 6
HEATING PLATEN ASSEMBLY.....	FIGURE 7
CONTROLLER VOLTAGE CONVERSION .....	FIGURE 8
CARRIAGE ASBY (MM2-EP,MM2H,MM2J,MM2B,MM2B-ARB,MM2BINTL,MM2BINTLCE) ..	FIGURE 9
CARRIAGE ASBY (MM2K-120, MM2K-ARB).....	FIGURE 9A
ADDITIONAL HANG-ON PARTS (MM2H, MM2J, MM2B, MM2B-ARB, MM2BINTL, MM2BINTLCE, MM2-EP) .....	FIGURE 10

# OWNER'S MANUAL

## MODEL HT18 HT10 AUTOTOAST™ HORIZONTAL TOASTER



SLIDE SHEET AND BELT WRAP INSTRUCTIONS .....DWG #169473

### **SCHEMATICS CONTROL GENERATION 1 (SEE PAGE 4)**

WIRING SCH (208 or 240V, 50/60HZ, 1PH) VARIABLE SPEED (*REVISED 5/4/06*) .....DWG #144046

WIRING SCH (208 or 240V, 50/60HZ, 1PH) VARIABLE SPEED (MM2G) .....DWG #150484

WIRING SCH (208 or 240V, 50/60HZ, 1PH) VARIABLE SPEED (MM2H).....DWG #150891

WIRING SCH (208 or 240V, 50/60HZ, 1PH) VARIABLE SPEED (MM2J) .....DWG #150881

WIRING SCH (208 or 240V, 50/60HZ, 1PH) VAR SPEED (MM2B, MM2C, MM2-EP) .....DWG #152229

WIRING SCH (240V, 50/60HZ, 1PH) VARIABLE SPEED (MM2BINTL, MM2BINTLCE) ..DWG #158451

WIRING SCHEMATIC (240V, 50/60HZ, 1PH) VARIABLE SPEED (MM2B-1) .....DWG #159717

WIRING SCHEMATIC (240V 50/60HZ 1PH) VARIABLE SPEED (MM2GINTL) .....DWG #157401

### **SCHEMATICS CONTROL GENERATION 2 (SEE PAGE 4)**

WIRING SCHEMATIC (208 OR 240V, 50/60HZ, 1PH) (MM2B-NC, MM2B-ARB) ..... DWG #163997

WIRING SCHEMATIC (220-240V, 1PH) (MM2BINTLCE-NC)..... DWG #164834

WIRING SCHEMATIC (220-240V, 1PH) (MM2GINTL-NC) ..... DWG #166307

WIRING SCHEMATIC (208-240V, 1PH) (MM2G-NC)..... DWG #166832

WIRING SCHEMATIC (220V, 1PH) (MM2BINTLDMK) ..... DWG #169235

WIRING SCHEMATIC (208-240V, 1PH) (MM2K-ARB) ..... DWG #167476

WIRING SCHEMATIC (120V) (MM2K-120)..... DWG #168320

# OWNER'S MANUAL

## MODEL HT18 HT10 AUTOTOAST™ HORIZONTAL TOASTER



### INSTALLATION

#### PRE-INSTALLATION

1. The toaster is packaged to minimize the risk of shipping damage. Immediately upon receipt, make certain to inspect the unit for damage. **FILE ALL CLAIMS WITH THE FREIGHT CARRIER.**
2. **It is necessary to check your voltage at the receptacle.** The voltage should match the toaster name plate. **CAUTION: DO NOT REMOVE THE ELECTRICAL CONTROL PANEL COVER ON THE RIGHT SIDE OF UNIT WITHOUT FIRST TURNING OFF THE TOASTER AND UNPLUGGING THE TOASTER.** See Figure 8 for instructions.

#### FINAL INSTALLATION

1. Place unit on a level surface. Be sure that location does not block the intake holes or slots at top of toaster.
2. Check that all covers are in place on the toaster.
3. Remove the plastic covering the top and sides.
4. Remove the conveyor carriage and wash with warm soapy water and sanitize.
5. Check that the toaster platen sheet is installed under the contact platens. The toaster platen sheet is installed by placing rods into arms of toaster. See Figure 4. Make sure seam is against platens (facing top of toaster). **USE ONLY MARSHALL APPROVED PLATEN SHEETS OR TOASTER WARRANTY IS VOID.**
6. Reinstall conveyor carriage and latch.
7. Connect the toaster to the power supply.
8. Press the on/off button and check for free movement of the two conveyor belts.
9. Unit is ready to use in approximately 15 minutes.
10. After warm up, insert buns into the toaster at the front of the unit. For proper operation, insert heels on the side of the toaster marked "Heel", and crown on the opposite side. **THE CUT SIDES OF THE HEEL AND CROWN MUST FACE UP.**
11. The toasted heel and crown will return to the toaster front together. Check the appearance of the toasted buns.
12. Adjust the gap between the conveyor and the toaster heat platens using the two knobs on top of the unit (see Figure 2 for knob locations). Both must be lowered at the same time. The knobs are labeled "HEEL" and "CROWN". The height gauges in the front indicate whether you are raising or lowering the platens. The Adjustment Ranges (except MM2B, G) are .625" – 1.438". The MM2B, MM2BINTLCE, MM2BINTLDMK, MM2G, MM2K range is .375" – 1.438".  
**NOTE:** For **MM2B-ARB** Models: Start with Crown @6, Heel @3.5-4. See detail A in Figure 1 for determination. Use the edge of the gauge metal not the scratched line from manufacturing.
13. The conveyor speed is preset at the factory. The approximate adjustable speed ranges for the MM2A unit toaster belt is 8 – 70 seconds; the MM2B and MM2G series is 9 – 105 seconds.

# OWNER'S MANUAL

## MODEL HT18 HT10 AUTOTOAST™ HORIZONTAL TOASTER



14. Test at least 3 buns before putting the toaster into service. Uniform surface toasting and bun temperature are achieved when the gap described in step 12 is set correctly.
15. If necessary, the speed of the conveyor can be changed. The speed control is located behind a box on the front of the unit. (See Figure 2) which can be removed using a 5/32 Allen wrench through the hole in the front. Adjust as needed and reinstall box.

### OPERATION (OPTIONAL PUSH BUTTON MM2A SERIES)

1. The toaster is operated by pressing and releasing the button on the right side of the unit.
2. Allow the toaster to heat up for at least 15 minutes prior to use.
3. For proper operation, insert heels cut side up on the side of the toaster marked "HEEL", and crowns on the opposite side.
4. To turn off, press and hold the button on right side of toaster for three (3) seconds. The toaster will cool enough to remove parts after at least 30 minutes.

### OPERATION (OPTIONAL 3 DIGIT CONTROL)

1. The toaster is operated by pressing and releasing the "I/O" Button of the control. "Lo" will be displayed.
2. The display of the control will show "Rdy" once the toaster is up to temperature. (Approximately 15 minutes.)
3. For proper operation, insert heels cut side up on the side of the toaster marked "HEEL", and crowns on the opposite side.
4. To turn off, press and hold the "I/O" Button for three (3) seconds. "Hi" will be displayed which means unit is still too hot to remove any parts. Once the toaster has cooled (approximately 30 minutes), the display will show "Off."
5. The LED Control will indicate important information:
  - A. Press and release either the Heat 1(Crown) or the Heat 2 (Booster) Button, the pre-programmed temperature settings will flash. This will display for 5 seconds or until another button is pressed.
  - B. Press and hold either the Heat 1(Crown) or the Heat 2 (Booster) Button for 3 seconds, the actual platen temperatures will be displayed. This will display until another button is pressed.
6. Definitions of various displays:

"Off"	Unit is off and not operating.
"Lo" or "Cool"	Heater platens have not reached programmed set temperature.
"Rdy"	Unit has reached programmed set temperature and is ready to toast.
"Hi"	Unit is off and too hot to touch most removable parts.
"AL1"	This is an alarm message that indicates the Left Platen Probe is disconnected or defective. Contact your local qualified service agency.
"AL2"	This is an alarm message that indicates the Right Platen Probe is disconnected or defective. Contact your local qualified service agency.
"AL3"	This is an alarm message that indicates the Left Platen is too hot. Unit shuts off. Contact your local qualified service agency.

# OWNER'S MANUAL

## MODEL HT18 HT10 AUTOTOAST™ HORIZONTAL TOASTER



“AL4” This is an alarm message that indicates the Right Platen is too hot. Unit shuts off. Contact your local qualified service agency.

### PREVENTIVE MAINTENANCE

#### DAILY CLEANING:

1. Remove conveyor carriage from toaster body. Take conveyor carriage to sink and spray with water.
2. Clean platen sheet three (3) times daily as listed below:
  - a. After lunch rush – Clean sheet in place using a damp cloth or non-abrasive pad. If sheet has black butter buildup, it must be wiped off. Use Sizzle cleaner if necessary.
  - b. After dinner rush – Clean sheet in place using a damp cloth or non-abrasive pad. If sheet has black butter buildup, it must be wiped off. Use Sizzle cleaner if necessary.
  - c. After closing – Remove sheet from toaster. Place on a flat surface and clean using a damp cloth or non-abrasive pad. If sheet has black butter buildup, it must be wiped off. Make sure to install sheet seam again platen (facing top of toaster).
3. Wipe any blockages that may be in the upper slots and holes on the side of toaster.
4. While toaster is in upright position, wipe cooling fan discharge with a dry cloth or towel.
5. MM2B Series Only: Wipe the product slide sheet and the bun ramp sheets. Use a damp cloth or non-abrasive pad. If sheet has black butter buildup, it must be wiped off.
6. Reinstall all parts after drying.

#### WEEKLY MAINTENANCE:

1. Perform Daily Maintenance.
2. Replace any worn out toaster platen sheets with Marshall Part #503983 (4 pack). **USE ONLY MARSHALL APPROVED PLATEN SHEETS OR TOASTER WARRANTY IS VOID.**

#### MONTHLY MAINTENANCE:

1. Perform Daily Maintenance.

#### QUARTERLY MAINTENANCE:

1. Inspect motor brushes. Replace if ¼” in length or shorter.
2. Perform Daily, Weekly & Monthly Maintenance.

#### ANNUALLY MAINTENANCE:

1. Replace two (2) motor brushes.

# OWNER'S MANUAL

## MODEL HT18 HT10 AUTOTOAST™ HORIZONTAL TOASTER



### TOASTER CONTROL DESIGNATION

Before any troubleshooting or replacement parts are ordered, it is necessary to determine the style of control that your toaster has. Generation 2 started in March 2014, but older toasters may or may not have been field upgraded from Generation 1 to Generation 2.



**GENERATION 1**  
Buttons to the right of the LED display.



**GENERATION 2**  
Buttons underneath the LED display.

### TROUBLESHOOTING GUIDE

**NOTE:** SERVICE MUST BE PERFORMED BY A QUALIFIED SERVICE COMPANY. THE TERM "QUALIFIED SERVICE COMPANY" MEANS ANY INDIVIDUAL, FIRM, CORPORATION OR COMPANY WHICH IS EITHER ENGAGED IN AND IS RESPONSIBLE FOR THE INSTALLATION OR REPLACEMENT OF ELECTRICAL COMPONENTS, OR THE CONNECTION, INSTALLATION OR REPAIR OF ELECTRICAL APPLIANCES, WHO IS EXPERIENCED IN SUCH WORK, FAMILIAR WITH ALL PRECAUTIONS REQUIRED, AND HAS COMPLIED WITH ALL THE REQUIREMENTS OF THE AUTHORITY HAVING JURISDICTION.

**WARNING:** INSPECTION, TESTING, AND REPAIR OF ELECTRICAL EQUIPMENT SHOULD BE PERFORMED BY QUALIFIED SERVICE PERSONNEL. THE UNIT SHOULD BE UNPLUGGED WHEN SERVICING, EXCEPT WHEN ELECTRICAL TESTS ARE REQUIRED.

**DANGER:** USE EXTREME CARE DURING ELECTRICAL CIRCUIT TESTS. LIVE CIRCUITS WILL BE EXPOSED. WHERE TESTING INDICATES "WITH POWER OFF", BE SURE THAT THE TOASTER IS UNPLUGGED.

- 1. PROBLEM:** Toaster shuts off intermittently and/or no heat and conveyor belts do not move. (Will not turn on.)

**SOLUTION:**

**OPERATOR CHECK:**

- Check that toaster is plugged in. Check condition of power cord and plug.
- Check circuit breaker in main breaker panel. Reset if necessary.
- If **LED control**, check for error message. "AL1" message is a defective left platen probe. "AL2" is a defective right platen probe. "AL3" is high temperature error of the left platen. "AL4" is high

# OWNER'S MANUAL

## MODEL HT18 HT10 AUTOTOAST™ HORIZONTAL TOASTER



a temperature error of the right platens. "AL3" and "AL4" alarms will turn unit off requiring a service call.

- D. If **push button** is on side panel, check two wires to make sure they are tight.

### QUALIFIED SERVICE TECHNICIAN CHECK:

- A. Check that there is power at receptacle. Verify voltage is correct based upon the voltage listed on the toaster nameplate.
- B. **WITH UNIT UNPLUGGED**, check connections inside of plug. Remove right side panel and check wiring. Any wires or terminals with burns or discoloration from arcing should be replaced. All wiring, if replaced, should be same or higher rated wire.
- C. Check sensors to see if OHM readings are correct. At room temperature (70°F), should be nominal 1.09K ohms. (NOTE: A defective sensor will not allow toaster to power on, but error messages are not visible if toaster is equipped with push button.)
- D. *With toaster off*, check for continuity across the solid state relay terminals #1 and #2. Normal readings are in mega ohm range. If reading ohms, relay has failed closed and will not cycle.
- E. **Control Generation 2 if no LED on display, check for .5 amp transformer fuses. If fuses good, check for 208 volts on terminals 1 and 6, then 18 Vac on 11 and 12. If 208 volts is present and no 18 Vac output, replace transformer.**

## 2. PROBLEM: Conveyor belts move but no heat.

### SOLUTION:

### QUALIFIED TECHNICIAN CHECK:

- A. Check that there is power at receptacle. Verify voltage is correct based upon the voltage listed on the toaster nameplate.
- B. Check for loose connections at terminal strip and temperature terminals (see schematic).
- C. Verify that the heater and sensor wires are connected to the controller.
- D. Replace all connections or components that have damaged terminals. Replace any damaged wiring with same or higher rated wire.
- E. Check the resistance of the sensor(s). If sensor is open, replace. At room temperature (70°F), Ohms should be nominal 1.09K ohms.
- F. Check voltage into solid-state relays. The voltage input from module should be approximately 5Vdc. Voltage to heater should be 208 or 240Vac.
- G. Check the resistance of the heater platens: 24 ohms at room temperature
- H. **Control Generation 2 – Check for 24Vdc to the heater relay (R1, R2) from the control board. If getting 24Vdc from the control board, check for 208 volts on output side of relay. If no 208 volts then replace relay. If there is 208 volts, then possible solid state relay problem.**

## 3. PROBLEM: Heater platens are hot, control says LO or RDY, conveyor belts do not move.

### SOLUTION:

### OPERATOR CHECK:

- A. Make sure carriage is pushed completely in and latch is engaged.
- B. Remove conveyor carriage and turn conveyors by hand and determine there is no binding due to dropping carriage.

# OWNER'S MANUAL

## MODEL HT18 HT10 AUTOTOAST™ HORIZONTAL TOASTER



- C. Make sure all setscrews on gears are tight.
- D. Check motor to make sure it is turning with carriage removed.

### QUALIFIED SERVICE TECHNICIAN CHECK:

- A. Check that there is power at receptacle. Verify voltage is correct based upon the voltage listed on the toaster nameplate.
- B. Check the fuses inside the right panel. Replace with type AGC 1.5 amp fuse if necessary. Check for red light on the speed board. If red light is lit, the motor is working too hard or in a stalled state.
- C. Some speed boards have a green light. If green light is lit then power is going to the board.
- D. Make sure the input voltage switch (es) of the speed board is set at 230V.
- E. Check for DC voltage out of board to motor.
- F. Check all wiring to motor for loose connectors.
- G. Check motor ohms, should be approximately 50-80 ohm s.

## 4. PROBLEM: Variable Speed Motor Not Operating

### SOLUTION:

### QUALIFIED SERVICE TECHNICIAN CHECK:

- A. Verify correct voltage to unit and motor.
- B. Check 1.5-amp fuses (#500061) inside right control panel. Replace if necessary.
- C. Check for DC voltage to motor out of board (90VDC Motor).
- D. Check motor ohms. Should be approximately 60 ohms.
- E. If red light on board is on, disconnect load from motor by removing conveyor carriage. If it goes out, look for conveyor binding. If it stays lit, replace motor –there is probably a gearbox problem.
- F. Check DC amp draws to motor by putting meter in series with motor. (Pull wire from A1 on board, put one lead to A1, other to wire pulled from A1.) When red LED on board is on, DC amp reading should be .3 amps approximately.
- G. If green LED is on and red is not, make sure that there is varying DC voltage out of board to motor (terminals A1 & A2 on board) as speed control knob is increased or decreased.
- H. Check for oil leaks on motor signifying bad seal or overheating that has taken place. In either case, motor should be replaced.

## 5. PROBLEM: Circuit Board not working properly. DO NOT ADJUST POTS ON BOARD!

### SOLUTION:

### QUALIFIED SERVICE TECHNICIAN CHECK:

- A. Verify AC voltage to board and DC voltage to motor from board. If there is AC voltage in, but no DC voltage out, replace board.
- B. Check all connections on board and terminal strip.
- C. Verify that board is wired correctly. (See schematic in Owner's Manual.)
- D. Make sure that switch on board is in 230V position.
- E. Make sure all wires are connected to potentiometer. A loose wire will make toaster run at single uncontrolled speed.

# OWNER'S MANUAL

## MODEL HT18 HT10 AUTOTOAST™ HORIZONTAL TOASTER



F. Control Generation 2 – Check for 24 Vdc from control board to motor relay (R3). If relay is getting 24 Vdc, check for 208 volts on output side of relay. If no 208 volts, replace relay.

### 6. PROBLEM: Product is over or under toasted.

#### SOLUTION:

#### OPERATOR CHECK:

- A. Check the gap settings. There must be compression of the bun as it feeds into the toaster. Decreasing the gap will increase bun temperature and darken surface color. To lower (decrease gap) turn knob counter-clockwise; to raise (increase gap) turn knob clockwise.
- B. Check toast time. Time should be 20 seconds nominal from start to finish.
- C. Check conditions of toaster platen sheet and belts. Clean both as noted in this manual.
- D. Make sure conveyor belts are not binding.
- E. Check drive system for loose sprockets.

#### QUALIFIED SERVICE TECHNICIAN CHECK:

- A. Check that heaters are cycling. Do this by using an amp clamp on either of the wires from the controller to the platen. You are looking for cycling. Also verify that the temperature controller has power.
- B. Check that the 3 wires from the speed board are hooked to the speed control.

### 7. PROBLEM: Buns do not feed properly into toaster.

#### SOLUTION:

#### OPERATOR CHECK:

- A. Check condition of the toaster platen sheet to be sure buns are not sticking. Clean sheet as described in daily maintenance. Replace if needed. Sheet should be rotated daily.
- B. Check toaster platen sheet installation.
- C. Toaster gap set too close or too far. See instructions on Page 1, Number 12.

### 8. PROBLEM: Buns do not exit toaster.

#### SOLUTION:

#### OPERATOR CHECK:

- A. Check condition of the toaster platen sheet to be sure buns are not sticking. Clean sheet as described in daily maintenance. Replace if needed. Sheet should be rotated daily.
- B. Check toaster platen sheet installation.
- C. Toaster platen gap set too close.

#### QUALIFIED SERVICE TECHNICIAN CHECK:

- A. Check tension on lower conveyor. If too loose, buns will not exit. Tighten conveyor by adjusting the Plate Tension Assembly (See Figure 5).

# OWNER'S MANUAL

## MODEL HT18 HT10 AUTOTOAST™ HORIZONTAL TOASTER



### 9. PROBLEM: Gap setting knobs jammed.

#### SOLUTION:

#### OPERATOR CHECK:

- A. Turn knobs counter-clockwise. Indicator is read using top edge.
- B. Turn both knobs at same time. Platen sheet could be interfering.

### 10. PROBLEM: Conveyors turning intermittently.

#### SOLUTION:

#### OPERATOR CHECK:

- A. Make sure carriage is pushed back and latch is engaged.
- B. Check for bent parts on the carriage; for example, handle, back flange.
- C. Check bottom rail flange for bending. Refer to the Technical Bulletin at the end of this manual for instructions.
- D. Tighten latch mechanism. Use a screwdriver and 7/16" wrench. It is necessary to remove right side cover to access.
- E. Conveyor bearings need replacing

### 11. PROBLEM: "Shim" required between latch and conveyor carriage to get conveyors to turn.

#### SOLUTION:

- A. Latch is bent. Bend latch back to straight.

### 12. PROBLEM: Conveyors continue to run after unit is turned off.

#### SOLUTION:

- A. Cycle On/Off again to see if motor stops.
- B. Motor must be replaced.

### 13. PROBLEM: Motor Noisy/Chirping

#### SOLUTION:

- A. Remove motor brushes and inspect. If  $\frac{1}{4}$ " less, replace with new.
- B. If longer than  $\frac{1}{4}$ ", replace brushes and tighten cap. Do not over tighten.

# OWNER'S MANUAL

## MODEL HT18 HT10 AUTOTOAST™ HORIZONTAL TOASTER



### REPLACEMENT PARTS: (See page 11 and 12 for electrical components)

When ordering parts, make sure to specify the model number and serial number as shown by the label attached on the back of toaster. **WARNING: Use of Non Marshall approved parts will void warranty.**

It is necessary to determine control style before specifying any electrical components for replacement. See page 11 and page 12 for information.

PART NUMBER	DESCRIPTION	FIGURE
144074	Arm, Front Tensioning	4, 4A
144075	Arm, Rear Tensioning Right	4, 4A
144058	Arm, Rear Tensioning Left	4, 4A
149404	Bar, Chain Support, Kit Set of 2	5
149275	Bearing, Shaft, Kit Set of 8	5
504297	Belt Wrap, Conveyor (MM2B, MM2BINTL)	9
150886	Bracket, Foot Brace (MM2J)	10
148549	Brush, Motor Right Angle Kit	Schematic
150425	Butterwheel (MM2B, MM2BINTL, MM2F, MMM2-EP)	10
144444	Carriage, Conveyor Asby (MM2A, MM2G)	3, 5
150939	Carriage, Conveyor Asby (MM2H)	3, 5
150873	Carriage, Conveyor Asby (MM2B, MM2BINTL, MM2J)	3, 9
160726	Carriage, Conveyor Asby (MM2-EP)	3, 9
167458	Carriage, Conveyor Asby (MM2K-120, MM2K-ARB)	3A
504015	Conveyor, Return	5
504001	Conveyor, Toaster	5
150878	Conveyor, Toaster (MM2B, MM2BINTL, MM2J, MM2-EP)	9
168117	Cover, Back Asby (MM2K-120, MM2K-ARB)	3A
144436	Cover, Speed Control (serial no. 1036 and after)	3, 3A
500263	Foot, 4" Tall	3A, 10
149277	Gear, Return and Drive, Kit Set of 3	5, 6
144435	Guard, Front Heat	3
158456	Guard, Heat w/Butterwheel (MM2B, MM2BINTL)	10
144876	Guard, Reflector Heat (MM2B-ARB)	3
504016	Idler, 1.405 Dia. (2 Per)	5
501717	Jumper	Schematic
500392	Jumper (MM2BINTLCE-NC, MM2K-ARB )	Schematic
161895	Kit, Toaster Foot for HT18 VT18 Toasters (Short)	Not Shown
504009	Knob, Adjustment	7
500088	Knob, Small (serial no. 1035 and before and 4692 & after)	Schematic
502147	Knob, Clear (serial no. 1036 – 4691)	3
501358	Nut, Adjustment Knob	7
164522	Pan, Crumb for Slide (MM2B-ARB Only)	10
167477	Pan, Bun Seed Ramp (MM2K-120, MM2K-ARB)	3A

# OWNER'S MANUAL

## MODEL HT18 HT10 AUTOTOAST™ HORIZONTAL TOASTER



REPLACEMENT PARTS CONT.: (See page 11 and 12 for electrical components)

PART NUMBER	DESCRIPTION	FIGURE
144027	Plate, Cover (serial no. 1035 and before)	3
144402	Plate, Idler Tensioning (4 Per)	5
167483	Platen, 5" X 12" (2 Per)	7
503981	Platen, 9" X 12" (2 Per)	7
144077	Rod, Toaster Platen Sheet 18.250" (2 per)	4
167494	Rod, Toaster Platen Sheet (2 per)	4A
144004	Shaft, Conveyor Drive (2 Per)	5
143749	Shaft, Idler (2 Per)	5
158195	Sheet, Product Return (MM2B, MM2BINTL, MM2-EP)	10
164652	Sheet, Product Return (MM2B-ARB)	10
168138	Sheet, Teflon (MM2K-120, MM2K-ARB)	3A
150418	Sheet, Teflon Loading (MM2B, MM2BINTL, MM2H, MM2J)	9
167495	Sheet, Toaster Platen Brn/Brn (MM2K-120, MM2K-ARB)	4A
149280	Sheet, Toaster Platen 4 Pack	4
167468	Shelf, Toaster Top (MM2K-120, MM2K-ARB)	3A
167479	Shield, Toaster Top Bun Asby (MM2K-120, MM2K-ARB)	3A
158454	Slide, Product Return (MM2B, MM2BINTL, MM2BINTLCE, MM2J, MM2-EP) (Not MM2B-ARB)	10
164521	Slide, Product Return (MM2B-ARB Only)	10
168110	Slide, Product Return (MM2K-120, MM2K-ARB)	3A
144405	Spacer, Conveyor (6 Per)	5
503191	Spring, Extension	4, 4A
504002	Spring, Tension (2 Per) Lower	5
504046	Spring, Tension (2 Per) Upper	5
149276	Sprocket, Kit W/Idlers	5
144078	Sprocket, Conveyor Asby (2 Per)	5
158125	Support, Chain Belt Kit	5
150941	Wrap, Bun Tray (MM2H)	10

# OWNER'S MANUAL

## MODEL HT18 HT10 AUTOTOAST™ HORIZONTAL TOASTER



### CONTROL GENERATION 1 ELECTRICAL REPLACEMENT PARTS

(NOTE: BUTTON LAYOUT TO RIGHT OF DISPLAY)



PART #	DESCRIPTION	FIGURE
<a href="#">504017</a>	Circuit Board, 230V (MM2A, MM2H)	Schematic
504107	Circuit Board, 230V (MM2G, MM2GINTL, MM2J)	Schematic
<a href="#">168870</a>	Kit, Control Retrofit HT18 Toaster	Schematic
<a href="#">504011</a>	Cord, 12/3 w/6-20 Plug (MM2A, MM2B, MM2B-ARB, MM2H, MM2J, MM2-EP)	Schematic
150483	Cord, 12/3 w/6-20 Plug (MM2G)	Schematic
504237	Cord Only, 12/3 Int'l (MM2BINTL)	Schematic
<a href="#">144139</a>	Fan, Cooling 240 Vac	Schematic
<a href="#">500068</a>	Fuse Holder	Schematic
<a href="#">500061</a>	Fuse, 1.5 AMP	Schematic
<a href="#">161003</a>	Kit, Sensor Replacement (2 per)	Schematic
500293	Lug, Ground	Schematic
<a href="#">503985</a>	Motor, Right Angle Drive	6
144016	Panel, LH Side	3, 3A
150887	Panel, LH Side (MM2J)	3
150889	Panel, RH Side (MM2J)	3
144017	Panel, RH Side (MM2A)	3
150482	Panel, RH Side (MM2G, MM2H)	3
<a href="#">502892</a>	Potentiometer, Rotary	Schematic
<a href="#">504023</a>	Relay, Solid State 25A	Schematic
<a href="#">148545</a>	Switch, Pushbutton Asby W/Boot	Schematic
<a href="#">500340</a>	Terminal Strip	Schematic
<a href="#">148595</a>	Wiring Harness Platens	Not Shown

# OWNER'S MANUAL

## MODEL HT18 HT10 AUTOTOAST™ HORIZONTAL TOASTER



### CONTROL GENERATION 2 ELECTRICAL REPLACEMENT PARTS

(NOTE: BUTTON LAYOUT UNDER DISPLAY)



PART #	DESCRIPTION	FIGURE
504017	Circuit Board, 230V (MM2A, MM2B, MM2B-ARB, MM2H, MM2K-120)	Schematic
504107	Circuit Board, 230V (MM2G, MM2GINTL, MM2J, MM2K-ARB)	Schematic
163975	Control Interface Board (LED Control)	Schematic
163582	Control I/O Board (MM2B-NC, MM2G-NC)	Schematic
164653	Control I/O Board (MM2B-ARB, MM2K-120, MM2K-ARB)	Schematic
164833	Control I/O Board (MM2BINTLCE-NC, MM2BINTLDMK)	Schematic
164073	Control I/O Board (MM2GINTL-NC)	Schematic
504290	Cord, 12/3 w/5-20 Plug (MM2K-120)	Schematic
504011	Cord, 12/3 w/6-20 Plug (MM2A, MM2B, MM2B-ARB, MM2G-NC, MM2H, MM2J, MM2-EP)	Schematic
150483	Cord, 12/3 w/6-20 Plug (MM2G)	Schematic
504237	Cord Only, 12/3 Int'l (MM2BINTL, MM2BINTLCE-NC, MM2GINTL-NC)	Schematic
504264	Cord 12/4 INTL (MM2BINTLDMK)	Schematic
502878	Cord, 16/3 w/6-15 Plug (MM2K-ARB)	Schematic
144139	Fan, Cooling 240 Vac	Schematic
504344	Fan, Cooling (MM2K-120)	Schematic
503574	Filter Noise ("CE" Units Only)	Schematic
500069	Fuse Block 2 Pole (MM2BINTLCE-NC, MM2BINTLDMK, MM2K-ARB)	Schematic
500068	Fuse Holder	Schematic
501139	Fuse, .5 AMP	Schematic
500061	Fuse, 1.5 AMP	Schematic
161003	Kit, Sensor Replacement (2 per)	Schematic
500293	Lug, Ground	Schematic
503985	Motor, Right Angle Drive	6, Schematic
502892	Potentiometer, Rotary	Schematic
504313	Relay, DC Coil Panel Mount 30A, 24VDC Coil	Schematic
504023	Relay, Solid State 25A	Schematic
163580	Sensor	Schematic
502603	Tab, Ground (MM2BINTLCE-NC, MM2BINTLDMK)	Schematic
500340	Terminal Strip	Schematic

# OWNER'S MANUAL

## MODEL HT18 HT10 AUTOTOAST™ HORIZONTAL TOASTER



PART #	DESCRIPTION	FIGURE
164650	Top, Heat Shield (MM2B-ARB Only)	Not Shown
504314	Transformer	Schematic
148595	Wiring Harness Platens	Not Shown

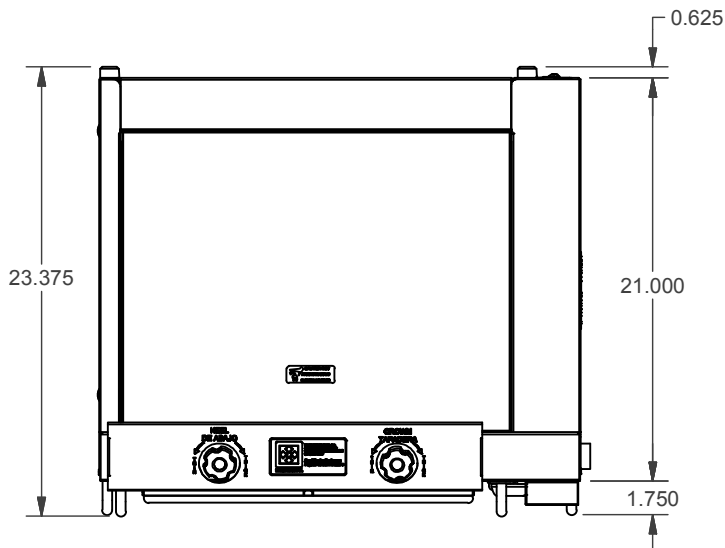

MODEL: HT18  
GAP ADJUSTMENT KNOB DETAIL

# FIGURE 1

THIS EDGE OF THE METAL GAUGE IS USED TO SET THE GAP BETWEEN THE CONVEYOR AND THE TOASTER

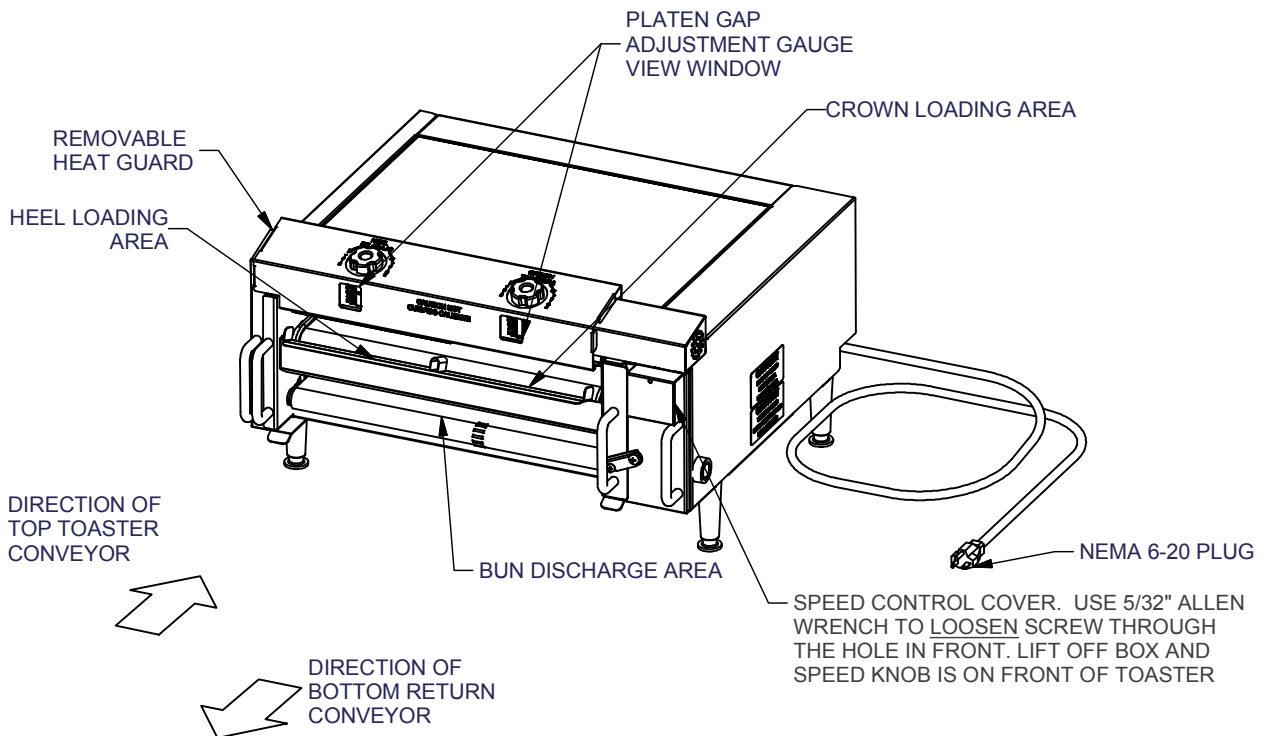
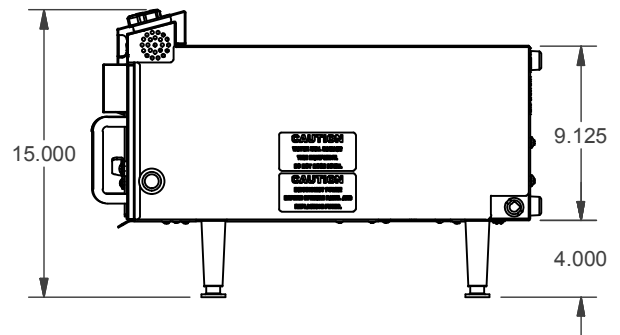
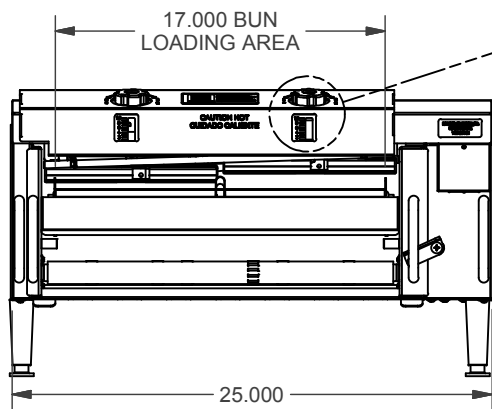
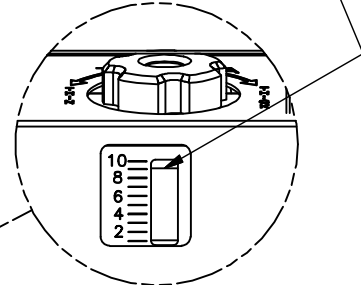

MODEL: HT18  
OVERALL UNIT DIMENSIONS

# FIGURE 2

MODEL: HT10  
GAP ADJUSTMENT KNOB DETAIL

# FIGURE 1A

THIS EDGE OF THE METAL GAUGE IS USED TO SET THE GAP BETWEEN THE CONVEYOR AND THE TOASTER

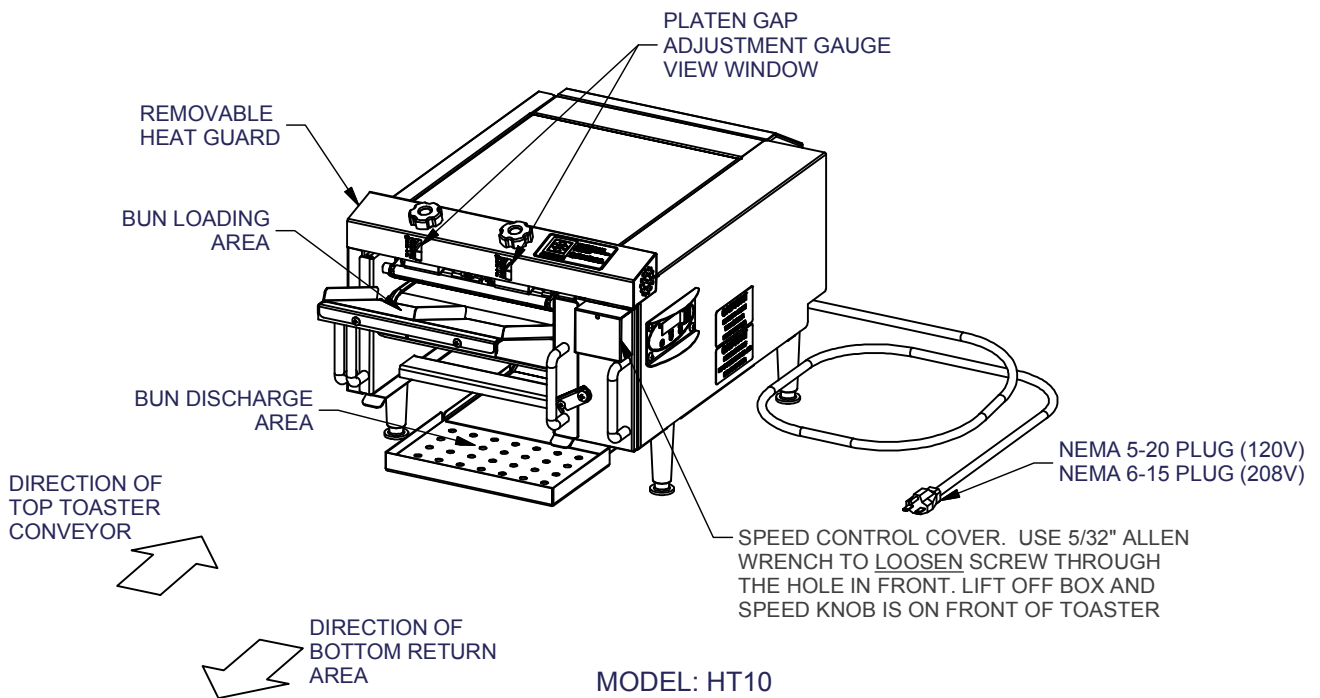
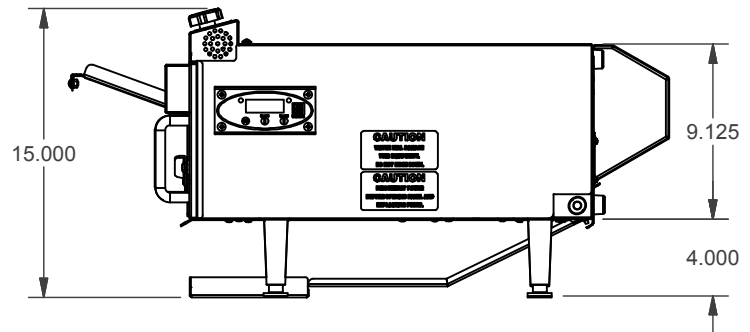
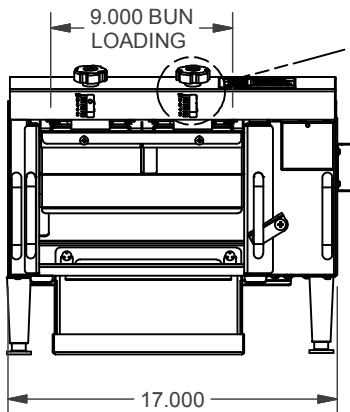
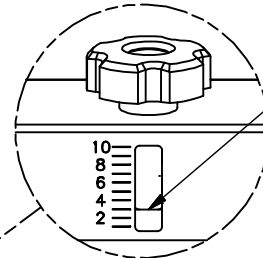
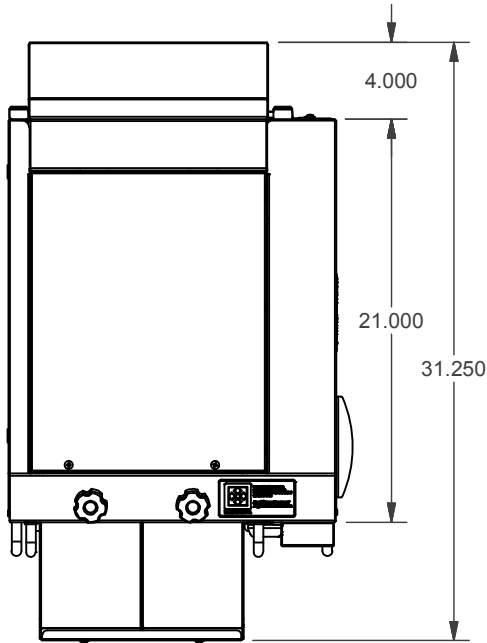

MODEL: HT10  
OVERALL UNIT DIMENSIONS

# FIGURE 2A

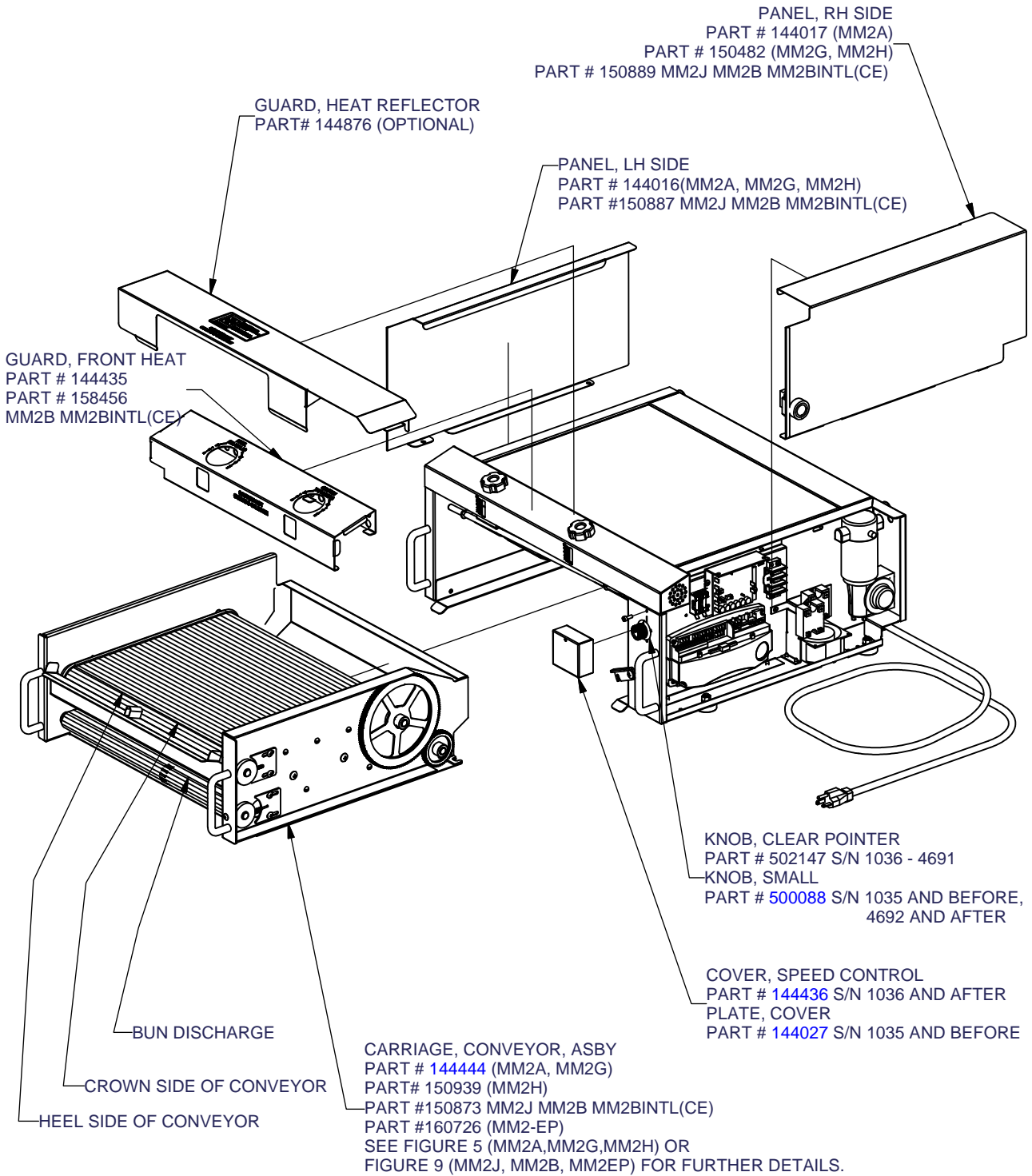

MODEL: HT18  
 HANG-ON PARTS  
**FIGURE 3**

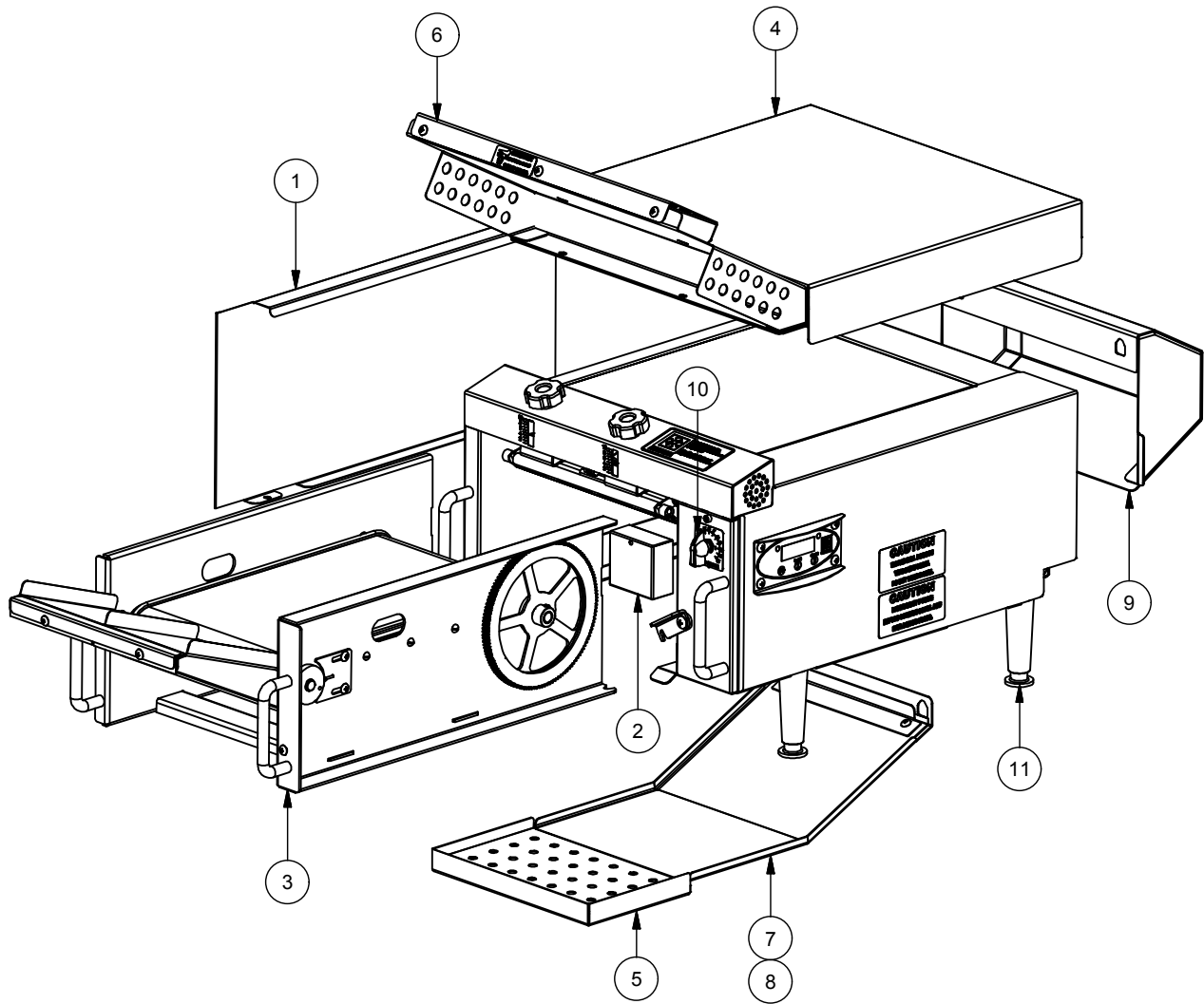

Parts List			
ITEM	PART NO.	TITLE	QTY
1	144016	PANEL, LH SIDE	1
2	144436	COVER, SPEED CONTROL	1
3	167458	ASBY, CARRIAGE CONVEYOR	1
4	167468	TOP, TOASTER SHELF	1
5	167477	PAN, BUN SEED RAMP	1
6	167479	SHIELD, TOASTER TOP BUN ASBY	1
7	168110	SLIDE, PRODUCT RETURN	1
8	168138	SHEET, TEFLON	1
9	168117	ASBY, BACK COVER	1
10	500088	KNOB, POTENTIOMETER, SMALL	1
11	500263	FOOT, APPLIANCE STYLE 4" TALL	4

MODEL: HT10  
HANG-ON PARTS  
**FIGURE 3A**

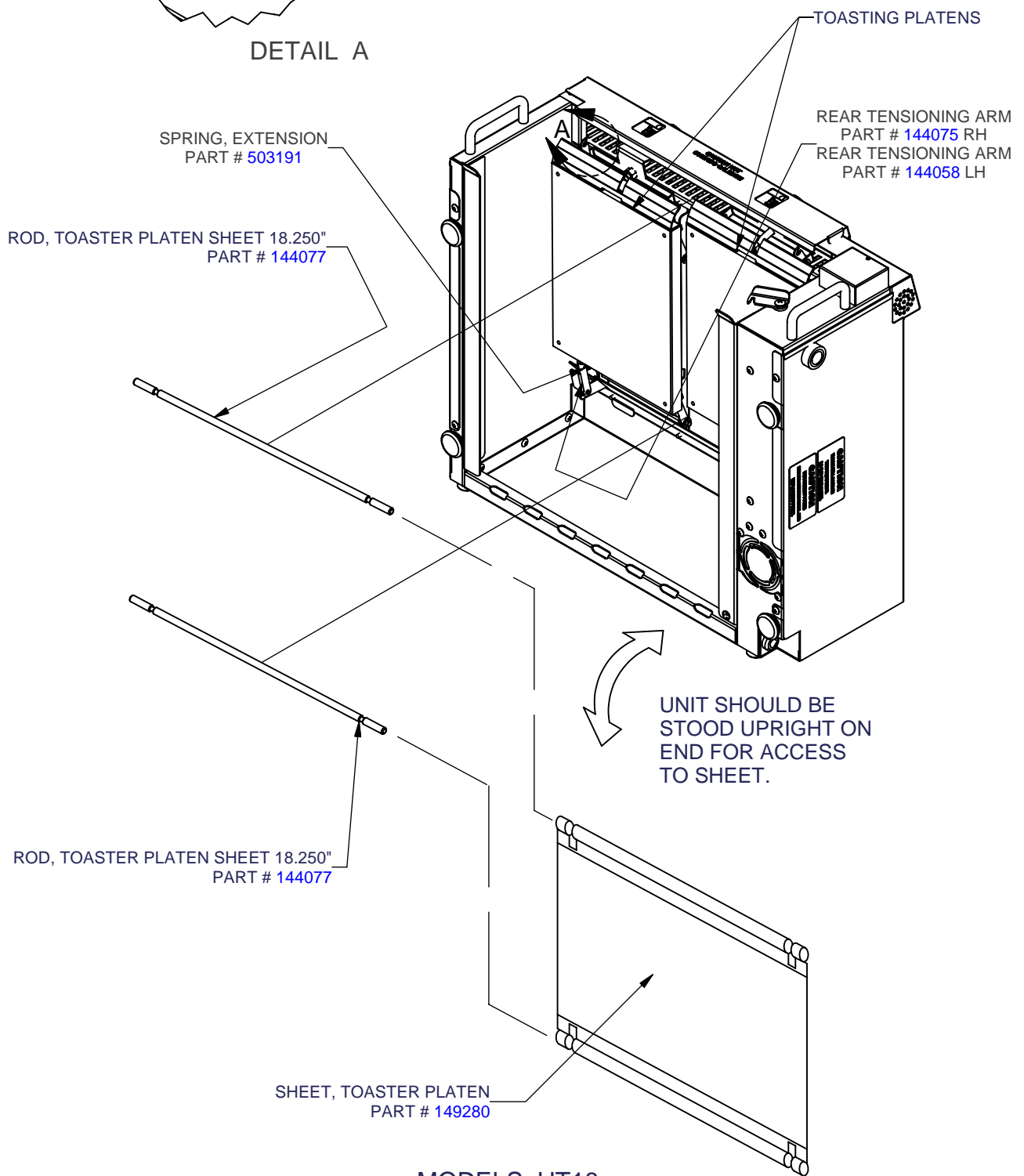
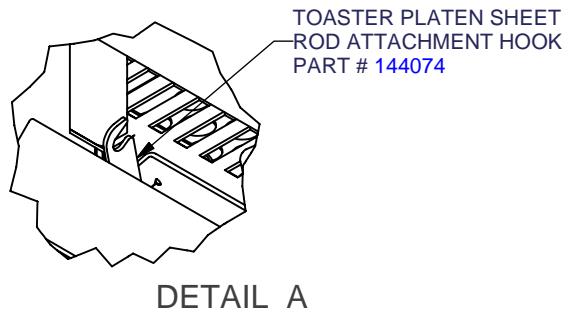

MODELS: HT18  
TOASTER PLATEN SHEET  
**FIGURE 4**

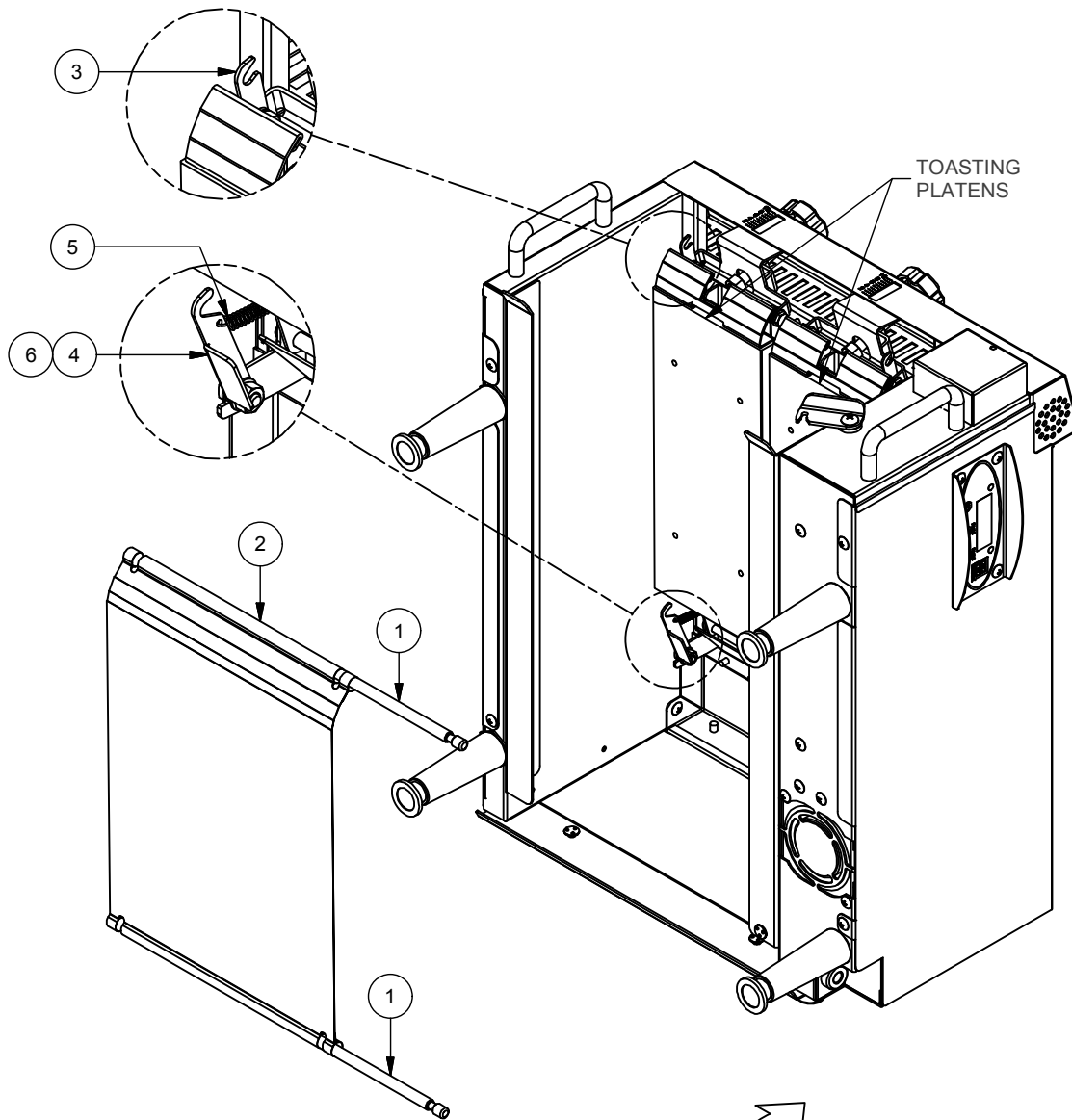

UNIT SHOULD BE  
STOOD UPRIGHT ON  
END FOR ACCESS  
TO SHEET.

Parts List			
ITEM	PART NO.	TITLE	QTY
1	167494	ROD, TOASTER PLATEN SHEET	2
2	167495	SHEET, TOASTER PLATEN BRN/BRN	1
3	144074	ARM, FRONT TENSIONING	1
4	144075	ARM, REAR TENSIONING LEFT	1
5	503191	SPRING, EXT 1.250" X .250"DIA	1
6	144058	ARM, REAR TENSIONING RIGHT	1

MODELS: HT10  
TOASTER PLATEN SHEET  
**FIGURE 4A**

CONVEYOR, TOASTER  
PART # 504001

SPROCKET, CONVEYOR ASBY  
PART # 144078

SPROCKET/IDLER KIT  
PART # 149276

SHAFT, CONVEYOR DRIVE  
PART # 144004

BEARING KIT  
PART # 149275

GEAR, RETURN  
AND DRIVE KIT  
PART # 149277  
CONSISTS OF  
(1) TOASTER AND  
(2) DRIVE GEARS

PLATE, TENSION ASBY  
PART # 144402

SPRING, TENSION  
PART # 504002  
LOWER CONVEYOR

SPRING, TENSION  
PART # 504046  
UPPER CONVEYOR

SHAFT, IDLER  
PART # 143749

BAR, CHAIN SUPPORT KIT  
PART # 149404

CONVEYOR, RETURN  
PART # 504015

IDLER  
PART # 504016

SUPPORT, CHAIN BELT KIT  
PART # 158125

LOADING RAMP  
REMOVED FOR  
CLARITY

SPACER, CONVEYOR  
PART # 144405

MODEL:MM2J MM2B MM2BINTL  
MM2-EP MM2BINTLCE HT18  
CARRIAGE ASSEMBLY

FIGURE 5

NOTE:  
UNIT SHOWN IN UPRIGHT  
POSITION, AS SHOWN IN FIGURE 4.  
THE CONVEYOR CARRIAGE IS  
REMOVED FOR CLARITY.

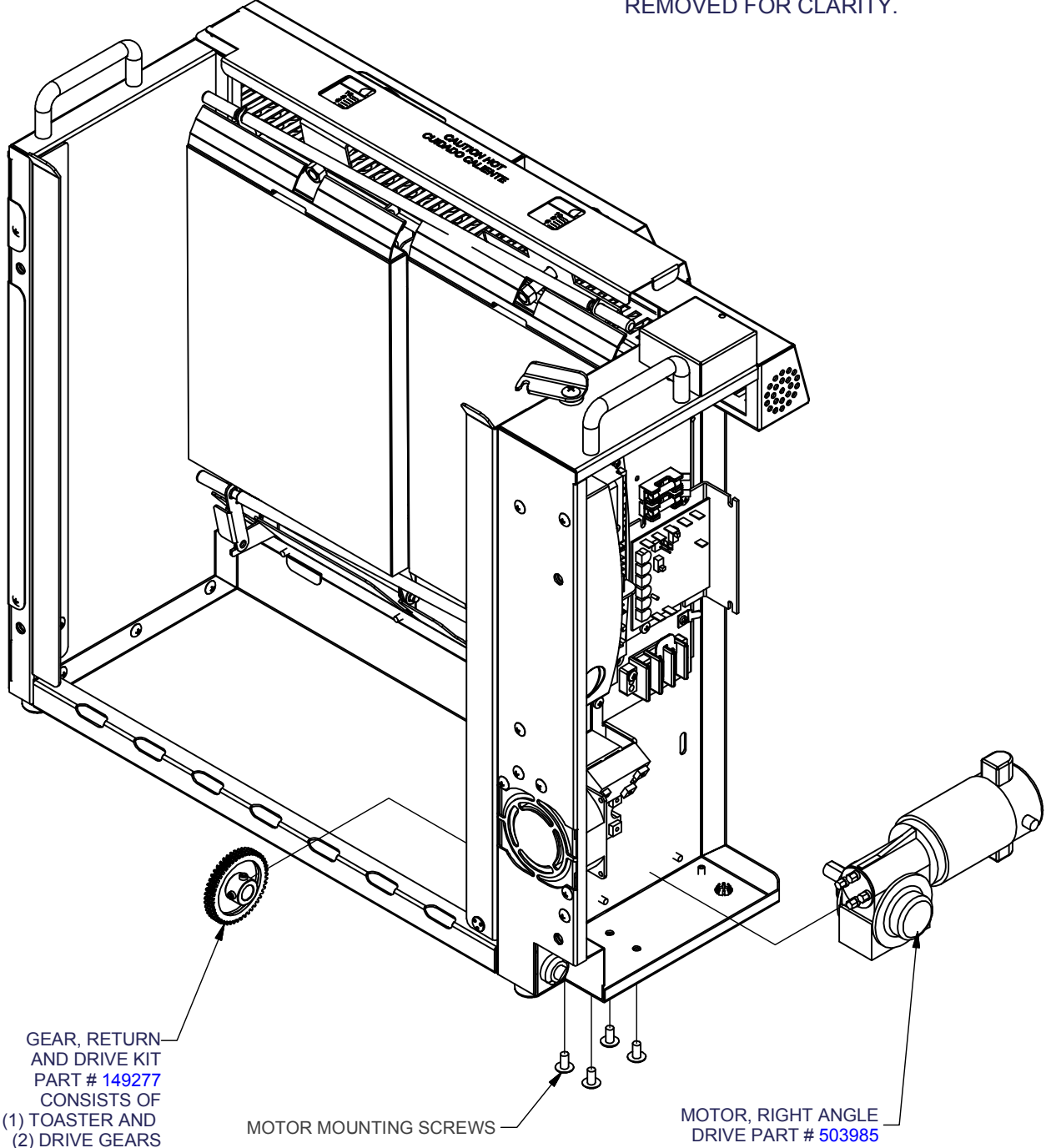

MODELS: HT18 & HT10  
DRIVE MOTOR ASSEMBLY  
FIGURE 6

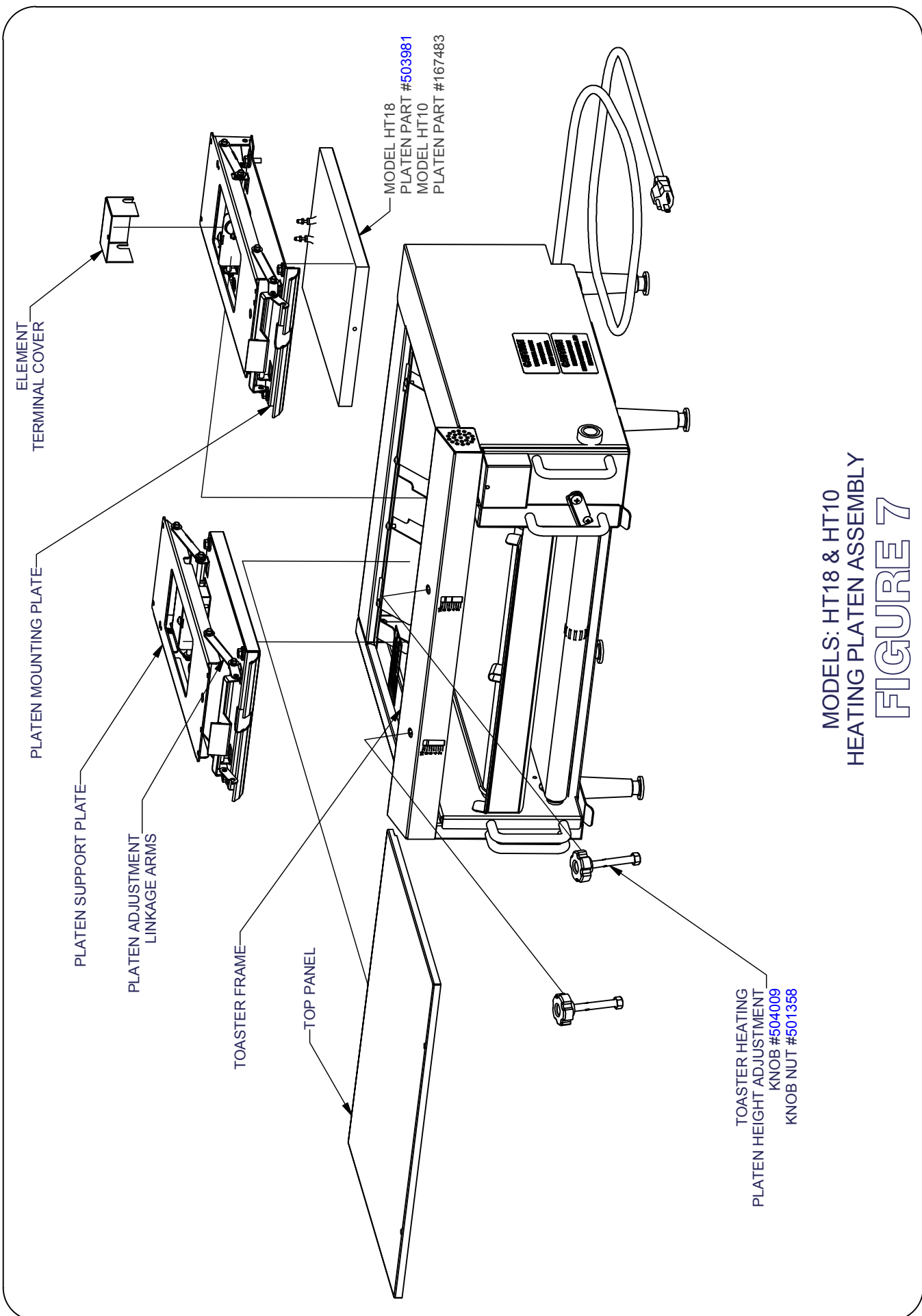

MODELS: HT18 & HT10  
 HEATING PLATEN ASSEMBLY  
**FIGURE 7**

CONTROL, ECM3 MODULE  
SEE DETAIL TO RIGHT

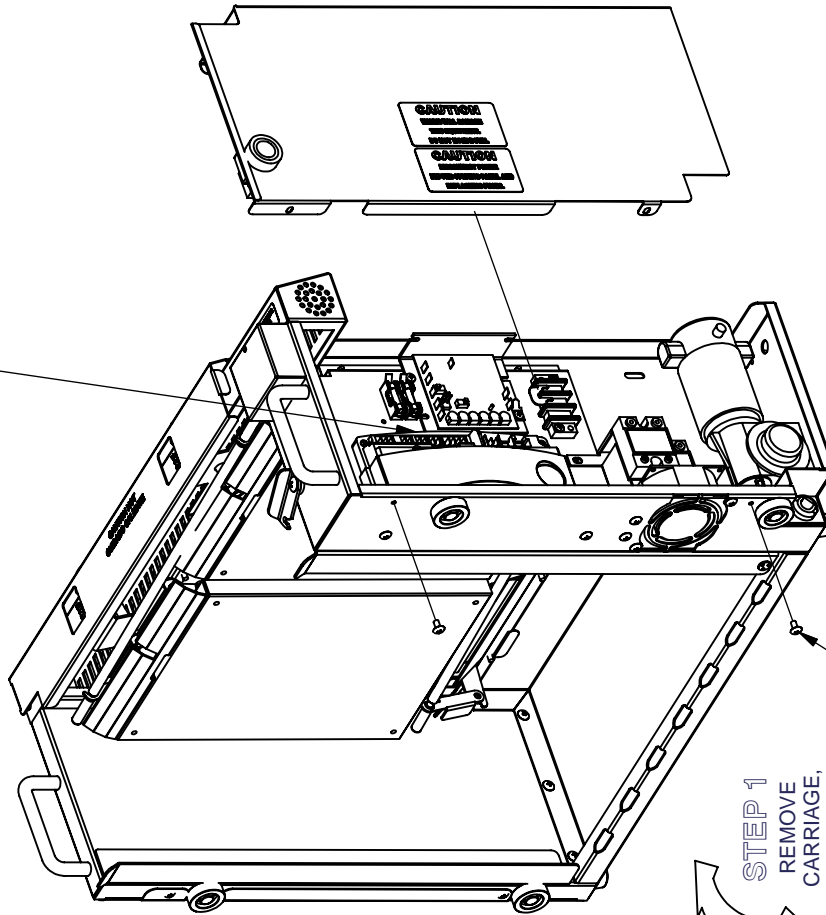

**STEP 1**  
REMOVE  
CARRIAGE,  
UNPLUG AND  
TURN UNIT  
UPRIGHT

**STEP 2**  
USING PHILIPS HEAD  
SCREW DRIVER REMOVE  
TWO SCREWS FOR  
SIDE PANEL REMOVAL.

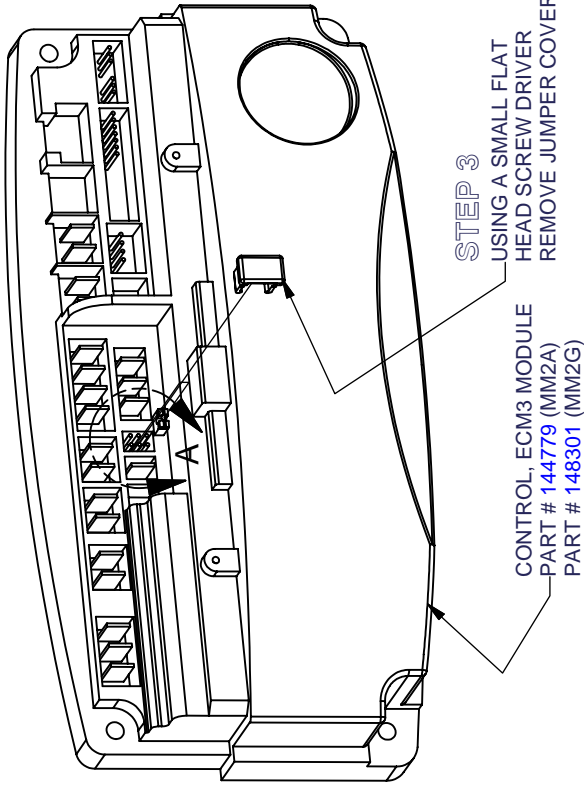

**STEP 3**  
USING A SMALL FLAT  
HEAD SCREW DRIVER  
REMOVE JUMPER COVER  
  
CONTROL, ECM3 MODULE  
PART # 144779 (MM2A)  
PART # 148301 (MM2G)

**STEP 4**  
USING A SMALL FLAT HEAD  
SCREW DRIVER, REMOVE THE  
JUMPER FROM THE 208V PIN  
AND MOVE IT DOWN TO THE  
230V PIN, DO NOT USE TOP  
PIN WITH 208 OR 230V OR  
DAMAGE WILL OCCUR.

**TOP PIN  
DO NOT  
USE**  
  
MIDDLE PIN  
208V  
  
BOTTOM PIN  
230V

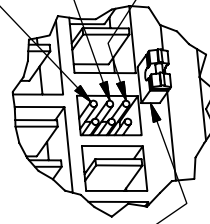

DETAIL A

MODEL: HT18  
CONTROLLER VOLTAGE  
CONVERSION

FIGURE 8

**CAUTION:** BE SURE THE UNIT IS UNPLUGGED OR  
ELECTRICAL SHOCK MAY OCCUR.

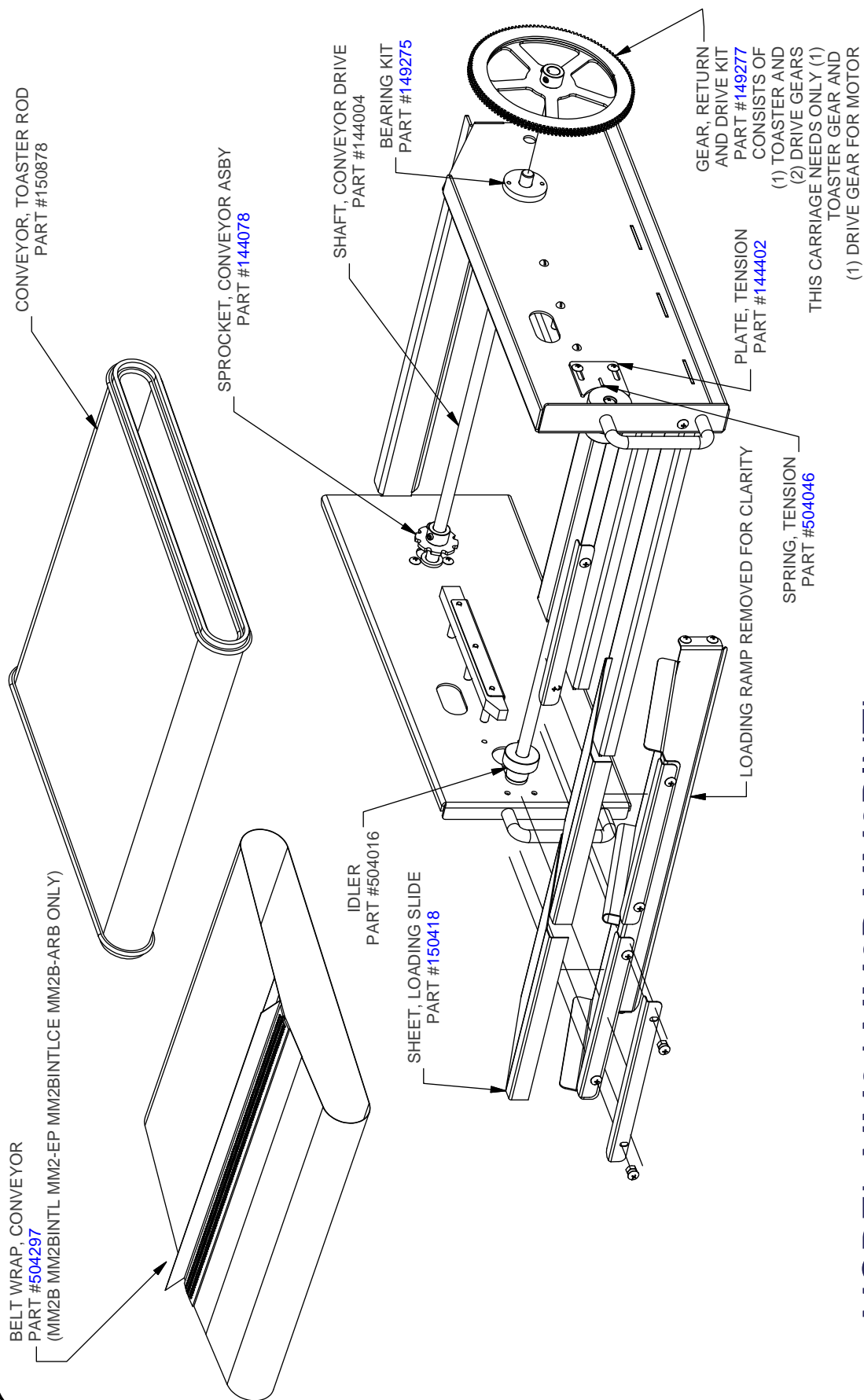

MODEL:MM2J MM2B MM2BINTL  
MM2-EP MM2BINTLCE MM2B-ARB HT18  
CARRIAGE ASSEMBLY  
FIGURE 9

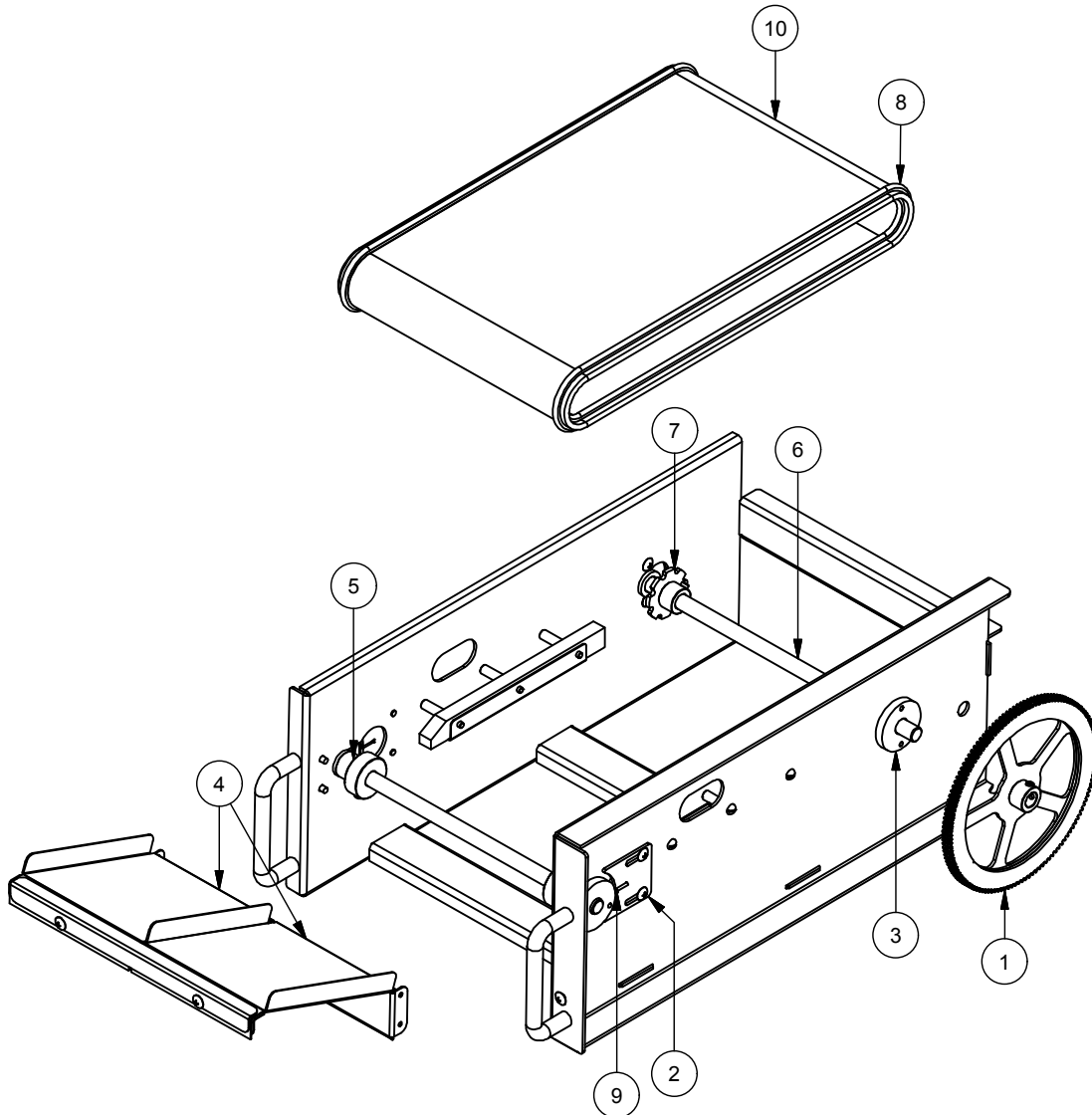

Parts List			
ITEM	PART NO.	TITLE	QTY
1	149277	KIT, GEAR RETURN AND DRIVE	1
2	144402	PLATE, IDLER TENSIONING	2
3	149275	KIT, BEARING	2
4	167461	SHEET, TELFON	2
5	144021	IDLER, 1.405" OD X .505" ID X .500"	2
6	167467	SHAFT, CONVEYOR DRIVE, 12.125"	1
7	144078	SPROCKET, CONVEYOR	2
8	503536	CONV BELT, 10" ROD, 7GA, .625" PITCH	1
9	504046	SPRING, COMP 1" X .180" DIA	2
10	504505	BELT WRAP, CONVEYOR 9 X 33	1

**MODEL: HT10**  
**CARRIAGE ASSEMBLY**  
**FIGURE 9A**

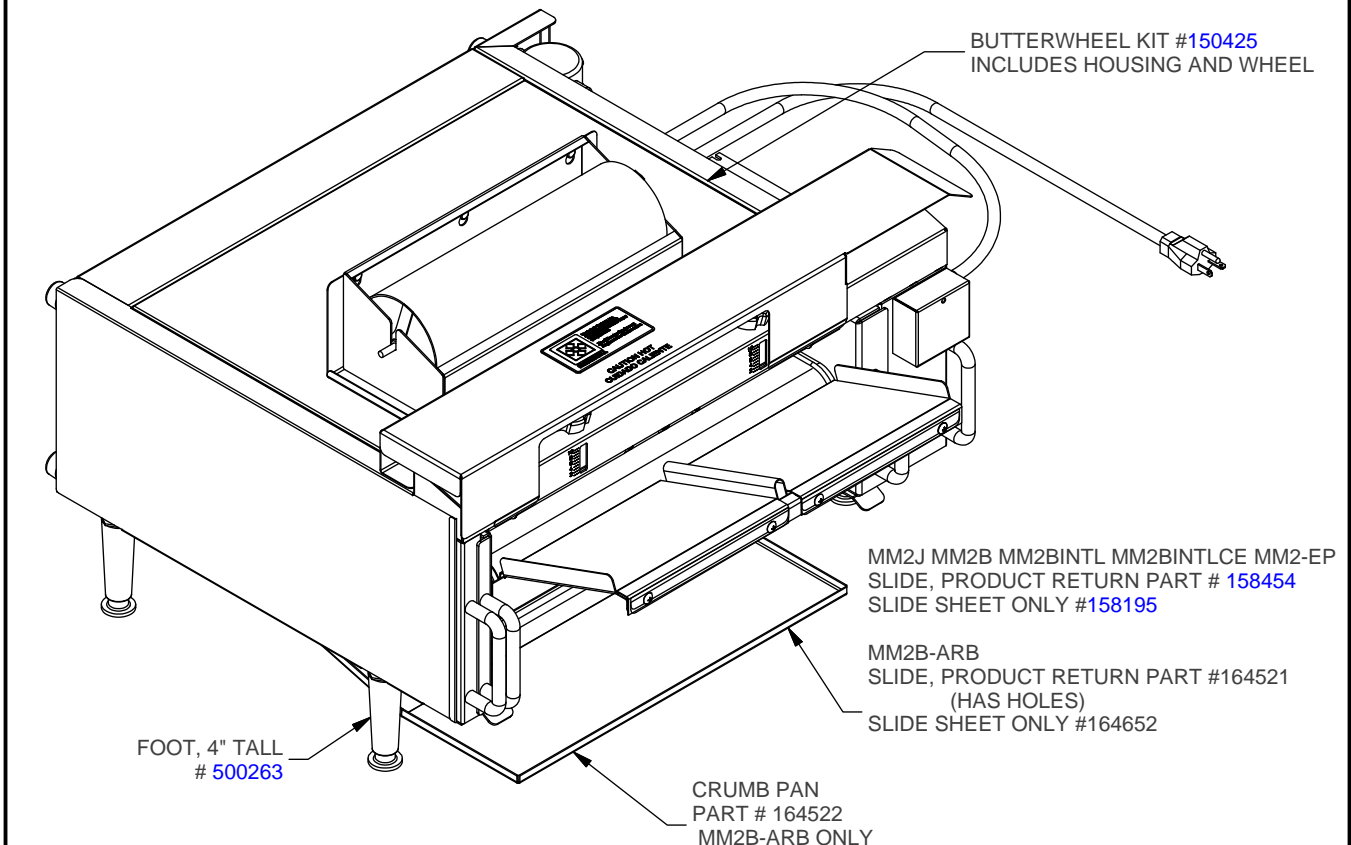
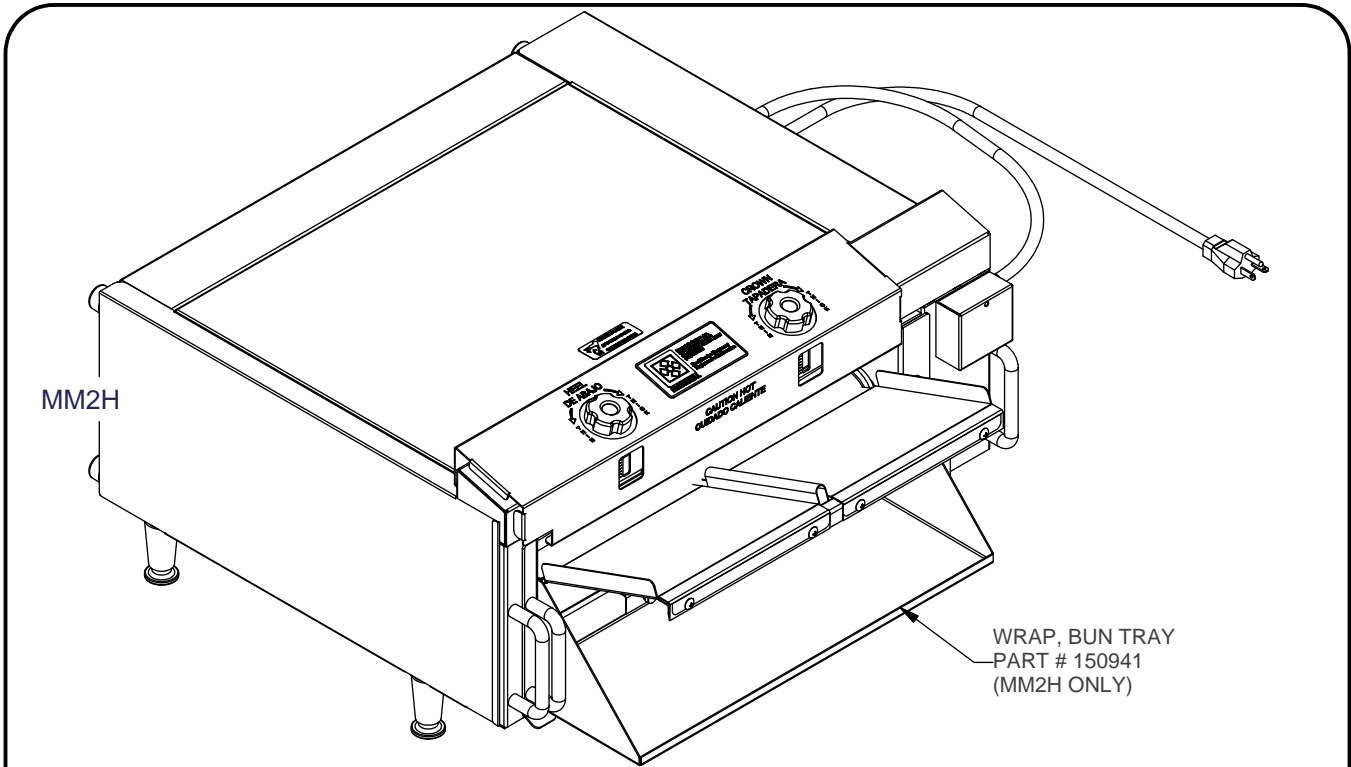

**MODEL: HT18 ADDITIONAL HANG-ON PARTS MM2H  
MM2J MM2B MM2B-ARB MM2BINTL MM2BINTLCE  
MM2-EP  
FIGURE 10**

# SLIDE SHEET AND BELT WRAP INSTRUCTIONS

## MODEL AUTOTOAST™ HT18



1. These instructions show how to replace all Slide Sheets and the Belt Wrap on your Marshall Air Model HT18 Autotoast™
2. **CAUTION.** Make sure all surfaces are not hot and cool to the touch.

1. Turn the power to the unit off by pressing I/O button. Then unplug the toaster from the electrical outlet.



2. Unlatch the carriage by pushing up on the latch on the right hand side of the toaster.



### FRONT ENTRANCE SLIDE SHEETS

1. Remove the screws holding the slide sheet clip. There are 2 screws for each clip / sheet.

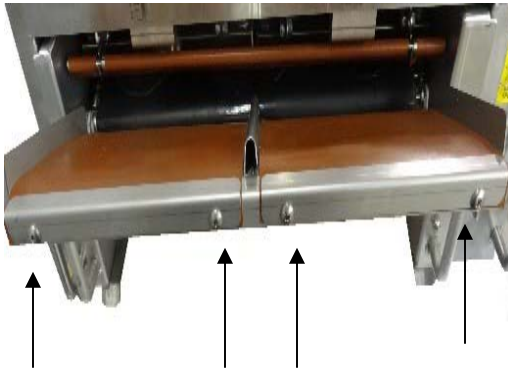

2. Remove the old slide sheet from entrance ramp.



3. Install the new slide sheet onto entrance ramp. Overlap the front edge where clip will be, 1/4".



4. While pushing down on the clip, re-install the hardware removed in Step 1.



# SLIDE SHEET AND BELT WRAP INSTRUCTIONS

## MODEL AUTOTOAST™ HT18



### BUN EXIT SLIDE SHEET

1. Loosen the 2 screws holding the slide sheet clip of the bun exit slide.



2. Remove the old slide sheet from under the slide sheet clip.



3. Install the new bun exit slide sheet onto the back of the bun exit slide. Overlap the edge where clip will be 1/4".



4. While pushing down on the clip, re-install the hardware removed Step 1.



### PLATEN SLIDE SHEET

1. Grab the left and right handles on the toaster and tilt the toaster back until it is lying on the back side of the toaster.

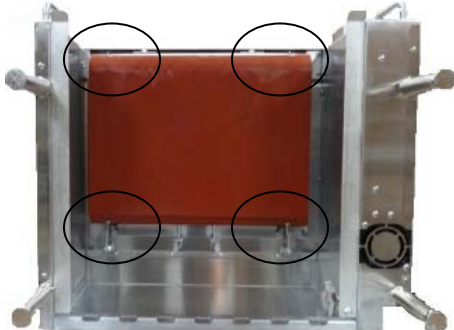

2. Remove the platen sheet rods from the toaster by pulling the left and right clips off the sheet rod at the **bottom**.



Platen slide sheet instructions continued on next page

# SLIDE SHEET AND BELT WRAP INSTRUCTIONS

## MODEL AUTOTOAST™ HT18



### PLATEN SLIDE SHEET Continued

3. After removing the sheet and sheet rods from the clips at the bottom, Lift the sheet rod out of the left and right clips at the **top**.



4. After removing the sheet from the toaster, slide out both of the rods from the sheet at the top and bottom

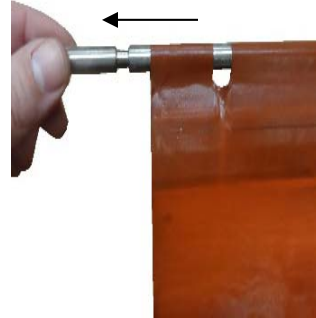

5. Insert the 2 rods removed in step 4, into the new sheet at the top and bottom. The smaller portion of the rod should align with the notches in the sheet

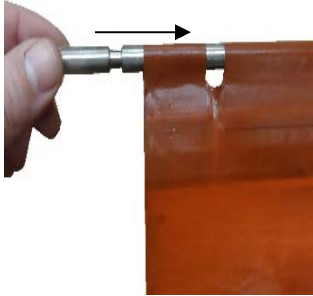

6. Re-install the sheet by inserting the sheet and rods into the top clips first. After the top rod is in place, insert the bottom rod into the bottom clips.

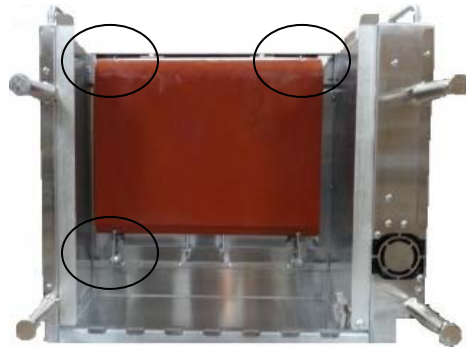

### CONVEYOR BELT WRAP REMOVAL

1. Rotate belt wrap until the seam is found.  
**CAUTION: IT MAY BE HOT!!!**



2. Position the seam at the hole in the frame side.



Conveyor belt wrap removal continued on next page

# SLIDE SHEET AND BELT WRAP INSTRUCTIONS

## MODEL AUTOTOAST™ HT18



### CONVEYOR BELT WRAP REMOVAL Continued

3. Lift up the belt flap, remove the pin by pulling it out the hole in the frame side. Needle nose pliers may be needed.  
**CAUTION: IT MAY BE HOT!!!**



4. Remove belt wrap from the rod conveyor belt.



5. Note the print on the NEW belt showing belt direction into toaster.



6. Place belt wrap around rod conveyor belt. MAKE CERTAIN TO ORIENT THE WRAP IN THE CORRECT DIRECTION WITH THE FLAP ON TOP AND TOWARD THE REAR OF THE CARRIAGE.



7. Align the sides of the belt wrap, mesh the teeth together as shown and insert the pin through the hole in the side frame. Insert the pin until flush with the belt wrap side.



8. Re-install carriage making sure the gears align and the carriage lock latches in place.



THIS SCHEMATIC IS FOR USE BY A QUALIFIED TECHNICIAN OR ELECTRICIAN ONLY.

**THIS SCHEMATIC FOR GENERATION 1 CONTROLS ONLY (110, HEAT 1, HEAT 2 TO RIGHT OF DISPLAY)**

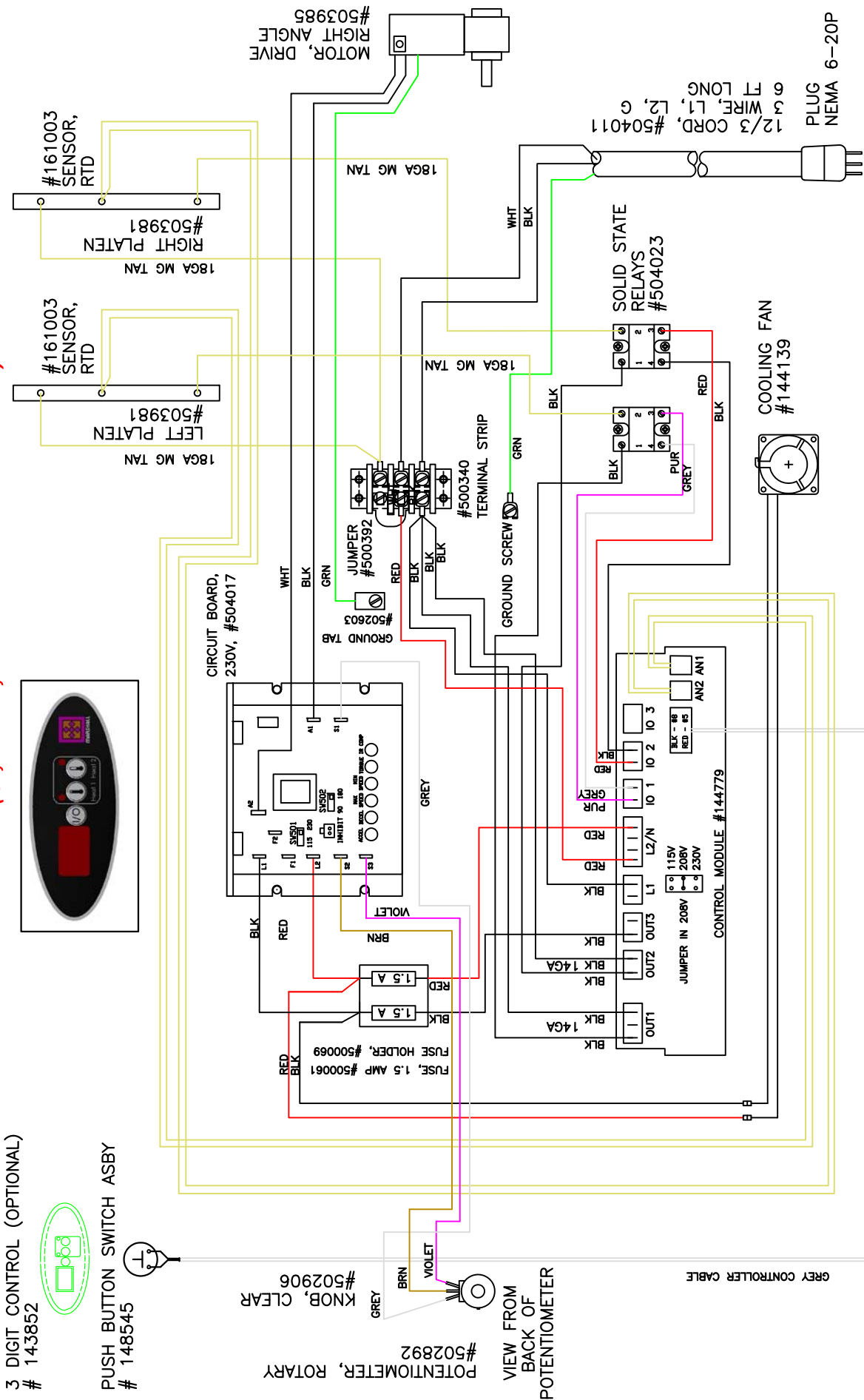

16-19 AMPS

REV	DESCRIPTION	DATE	REV.	BY	DRAWN BY:	DATE:	REV DATE:
18	ADDED CONTROL TYPE 1 NOTES	4/4/2014		PW	P.W.	09-JUN-2003	-
17	#161003 WAS #503590	1/21/2013		S.A.	MARSHALL AIR SYSTEMS, INC.		
16	ADDED BUTTON WIRE DESIGNATION	05-OCT-2011		P.W.	SCHEMATIC		
15	CHG CIRC BOARD WIRING	25-SEP-2006		P.W.	PRODUCT CLASS: TST		
14	CHG BUTTON SWITCH FROM 504062	04-MAY-2006		P.W.	SIZE: ROUTE: ELECT		
13	UPDATE SPEED BOARD ILLUSTRATION	14-NOV-2005		C.M.	SCALE: 1:1 IMAGE MAY BE REDUCED		
					DWG. NO.: 144046		
					REV: 18		
					CODE: MM2A		

THIS SCHEMATIC IS FOR USE BY A QUALIFIED TECHNICIAN OR ELECTRICIAN ONLY.

**THIS SCHEMATIC FOR GENERATION 1 CONTROLS ONLY (110, HEAT 1, HEAT 2 TO RIGHT OF DISPLAY)**

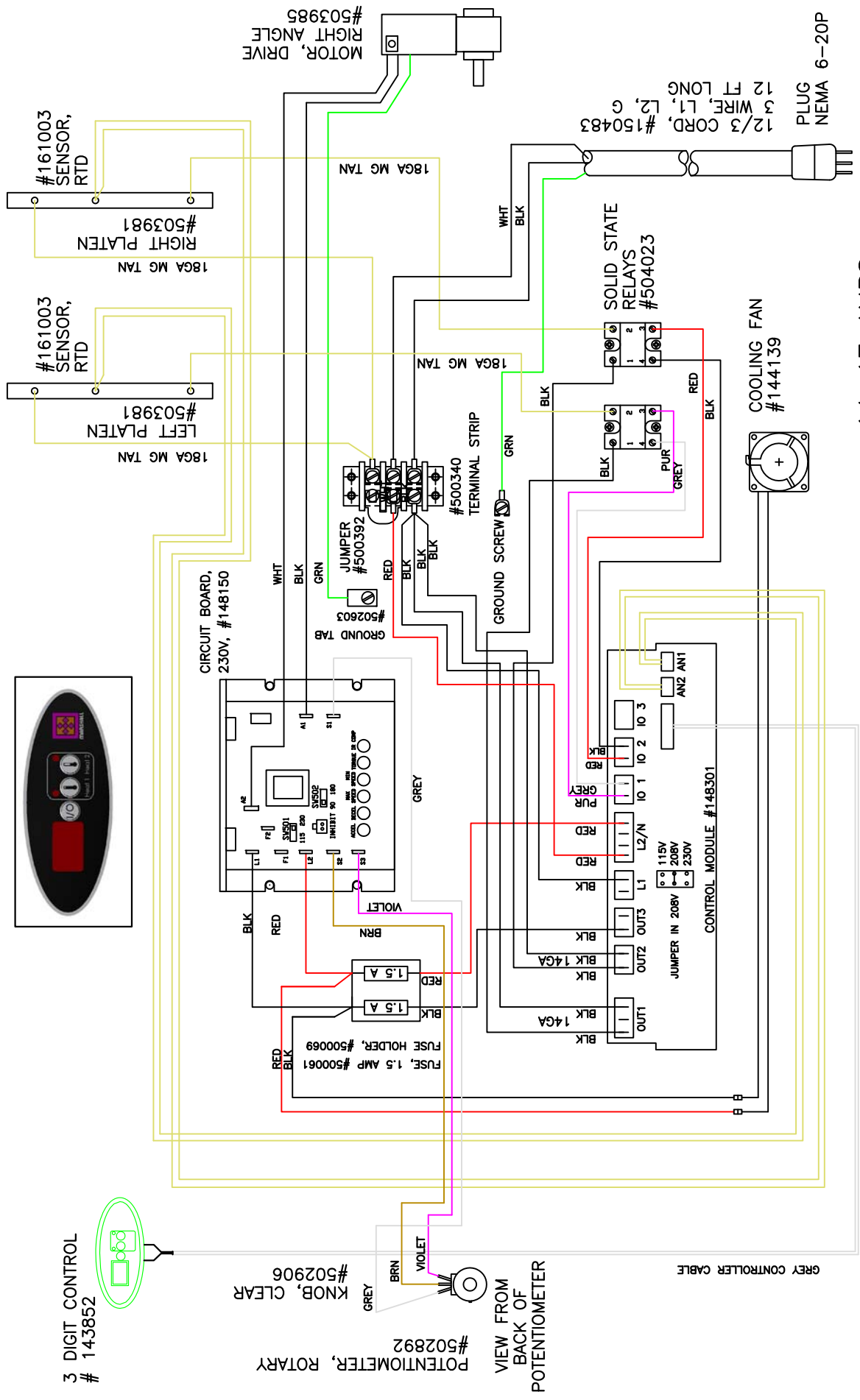

14-17 AMPS

REV	DESCRIPTION	DATE	REV.	BY	DRAWN BY:	DATE:	REV DATE:
1	SWITCHED BLK WHT MOTOR WIRE	01/10/112	PW		J.L.	29-AUG-2007	-
2	#161003 WAS #503590	1/21/2013	S.A.				
3	ADDED CONTROL TYPE 1 NOTES	4/4/2014	PW				

MARSHALL AIR SYSTEMS, INC.	
SCHEMATIC, HT18, 208 OR 240 1 PH	
W/ LED CONTROL, VARIABLE SPEED	
SIZE: ROUTE: ELECT	DWG. NO.: 150484
A	3
SCALE: IMAGE MAY BE REDUCED	CODE: MM2G
NTS	NTS
REFERENCE	

THIS SCHEMATIC IS FOR USE BY A QUALIFIED TECHNICIAN OR ELECTRICIAN ONLY.

**THIS SCHEMATIC FOR GENERATION 1 CONTROLS ONLY (110, HEAT 1, HEAT 2 TO RIGHT OF DISPLAY)**

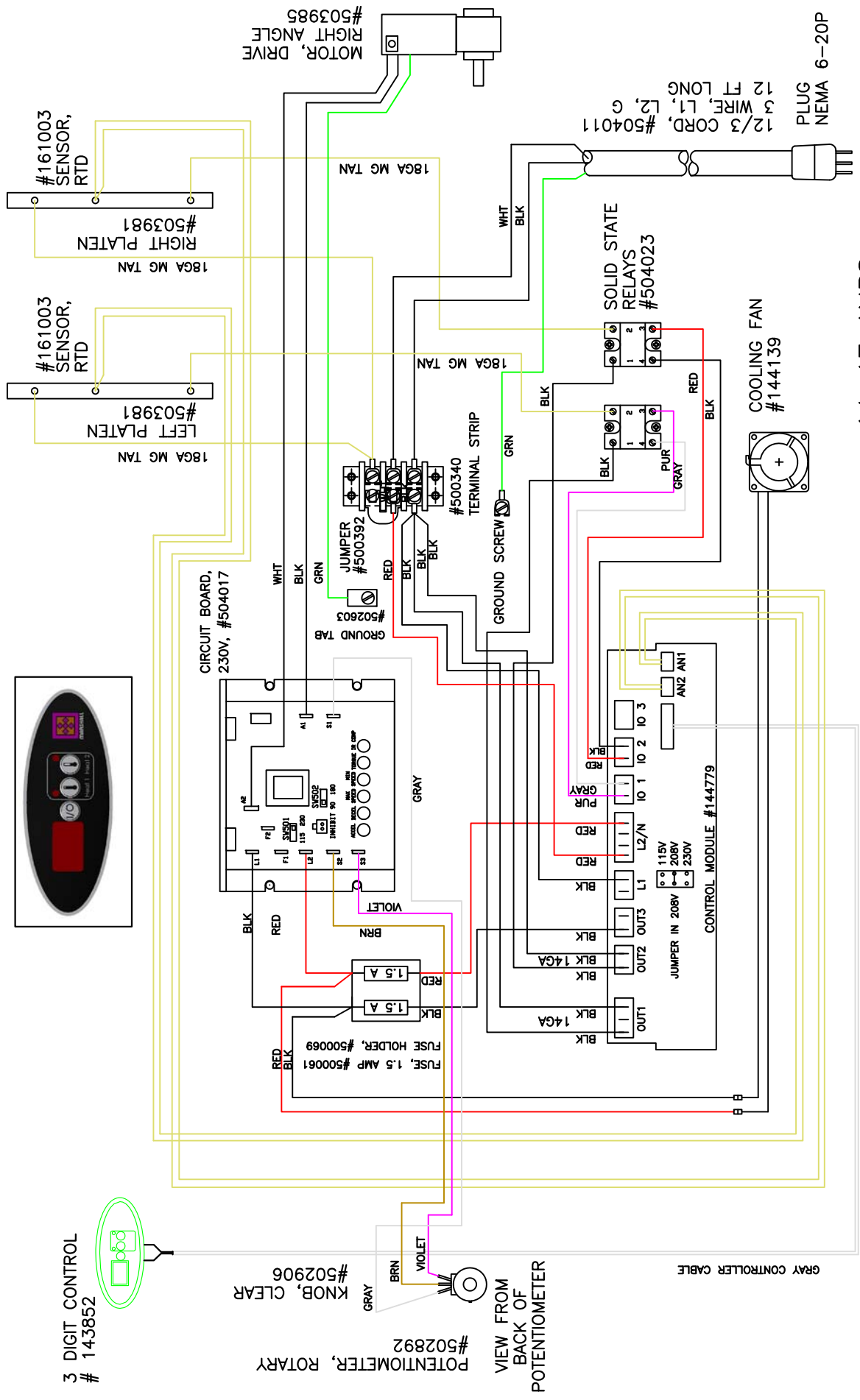

14-17 AMPS

REV	DESCRIPTION	DATE	REV. BY
1	#161003 WAS #503590	1/21/2013	S.A.
2	ADDED CONTROL TYPE 1 NOTES	4/4/2014	PW

DRAWN BY: J.L. 19-OCT-2007		DATE: 19-OCT-2007	
GENERIC NAME: SCHEMATIC		PRODUCT CLASS: TST	
FAB: REFERENCE		MATERIAL: REFERENCE	
SIZE: A	ROUTE: ELECT	DWG. NO.: 150891	REV.: 2
SCALE: NTS	IMAGE MAY BE REDUCED	CODE: MM2H	

**MARSHALL AIR SYSTEMS, INC.**

SCHEMATIC, HT18, 208 OR 240V 1 PH  
W/ LED CONTROL, VARIABLE SPEED

THIS SCHEMATIC IS FOR USE BY A QUALIFIED TECHNICIAN OR ELECTRICIAN ONLY.

**THIS SCHEMATIC FOR GENERATION 1 CONTROLS ONLY (110, HEAT 1, HEAT 2 TO RIGHT OF DISPLAY)**

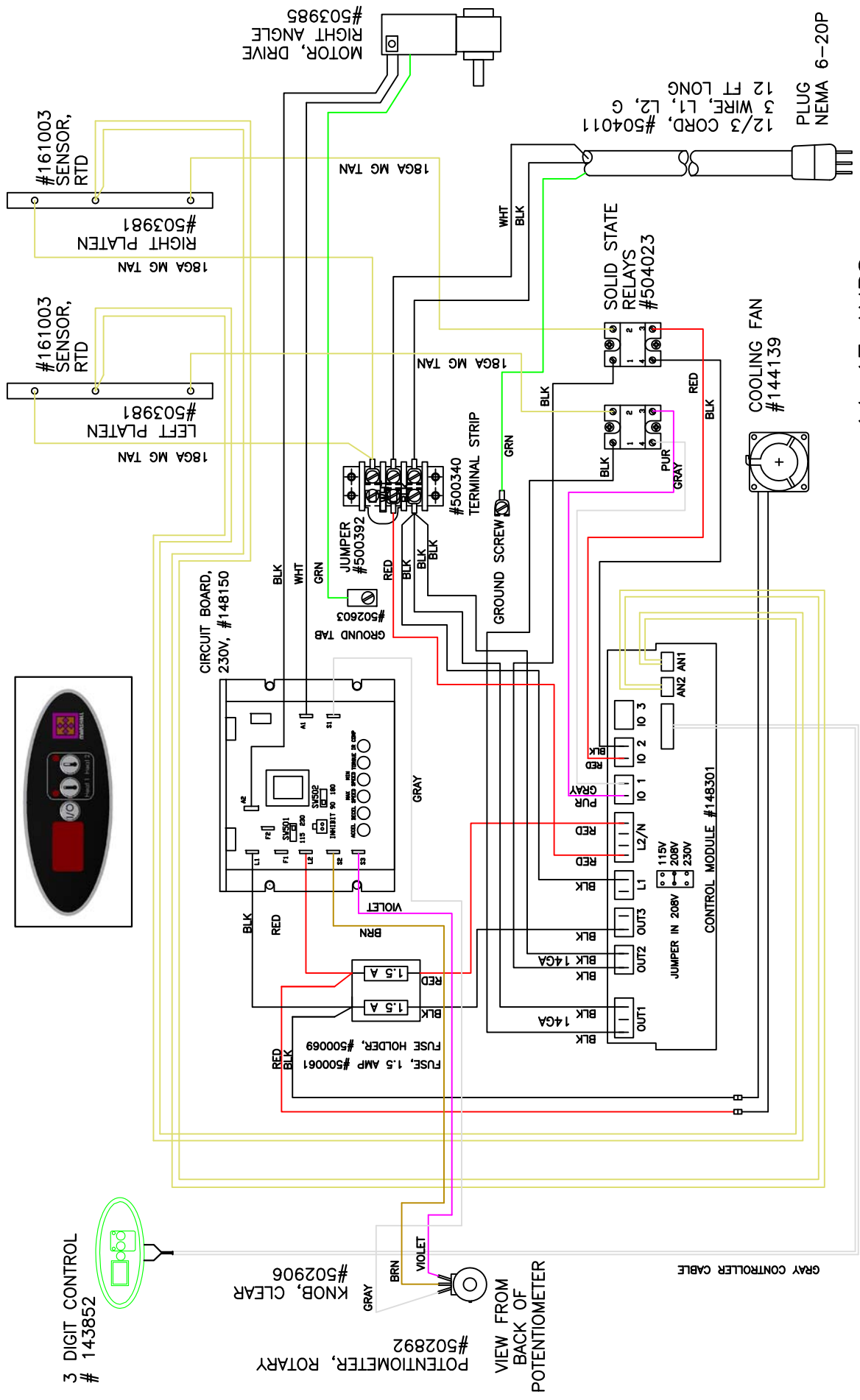

14-17 AMPS

REV	DESCRIPTION	DATE	REV. BY
1	#161003 WAS #503590	1/22/2013	S.A.
2	ADDED CONTROL TYPE 1 NOTES	4/4/2014	PW

DRAWN BY: J.L. 18-OCT-2007		DATE: 18-OCT-2007	
GENERIC NAME: SCHEMATIC		PRODUCT CLASS: TST	
FAB: MATERIAL: REFERENCE		SIZE: ROUTE: ELECT	
DWG. NO.: 150881		REV.: 2	
SCALE: IMAGE MAY BE REDUCED		CODE: MM2J	
NTS		NTS	

**MARSHALL AIR SYSTEMS, INC.**

SCHEMATIC, HT18, 208 OR 240V 1 PH  
W/ LED CONTROL, VARIABLE SPEED

152229

THIS SCHEMATIC IS FOR USE BY A QUALIFIED TECHNICIAN OR ELECTRICIAN ONLY.

**THIS SCHEMATIC FOR GENERATION 1 CONTROLS ONLY (I10, HEAT 1, HEAT 2 TO RIGHT OF DISPLAY)**

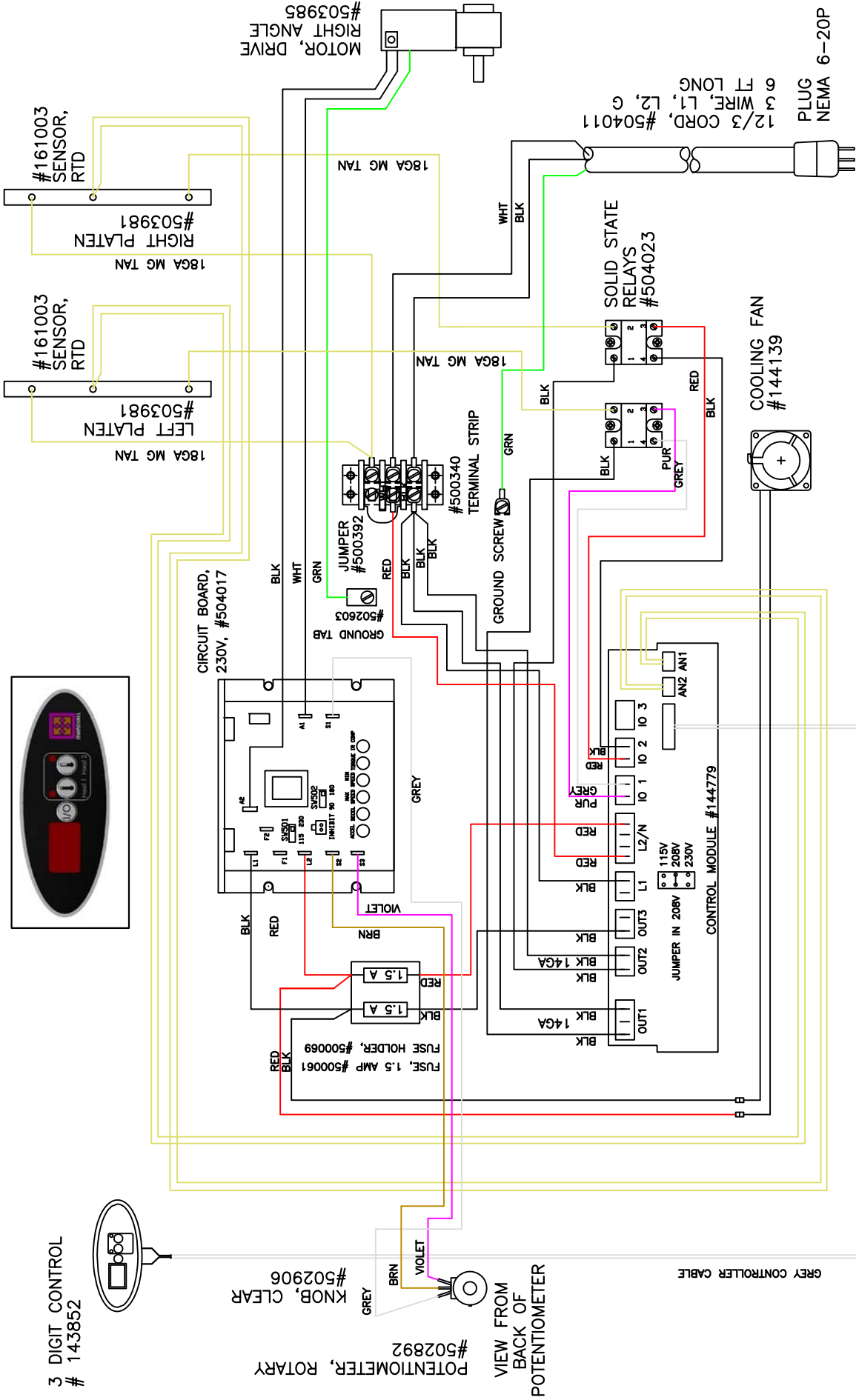

14-17 AMPS

REV	DESCRIPTION	DATE	REV.	BY
1	SWAPED WHITE AND BLACK WIRE FROM A1 AND A2	7/18/2012	S.A.	
2	#161003 WAS #503590	1/22/2013	S.A.	
3	ADDED CONTROL TYPE 1 NOTES	4/4/2014	PW	

DRAWN BY: J.L. 06-OCT-2008		DATE: 06-OCT-2008	
GENERIC NAME: SCHEMATIC		PRODUCT CLASS: TST	
FAB		MATERIAL: REFERENCE	
SIZE: A	ROUTE: ASBY	DWG. NO.: 152229	REV: 3
SCALE: NTS	IMAGE MAY BE REDUCED	CODE: MM2B MM2C	MM2-EP

THIS SCHEMATIC IS FOR USE BY A QUALIFIED TECHNICIAN OR ELECTRICIAN ONLY.

**THIS SCHEMATIC FOR GENERATION 1 CONTROLS ONLY (110, HEAT 1, HEAT 2 TO RIGHT OF DISPLAY)**

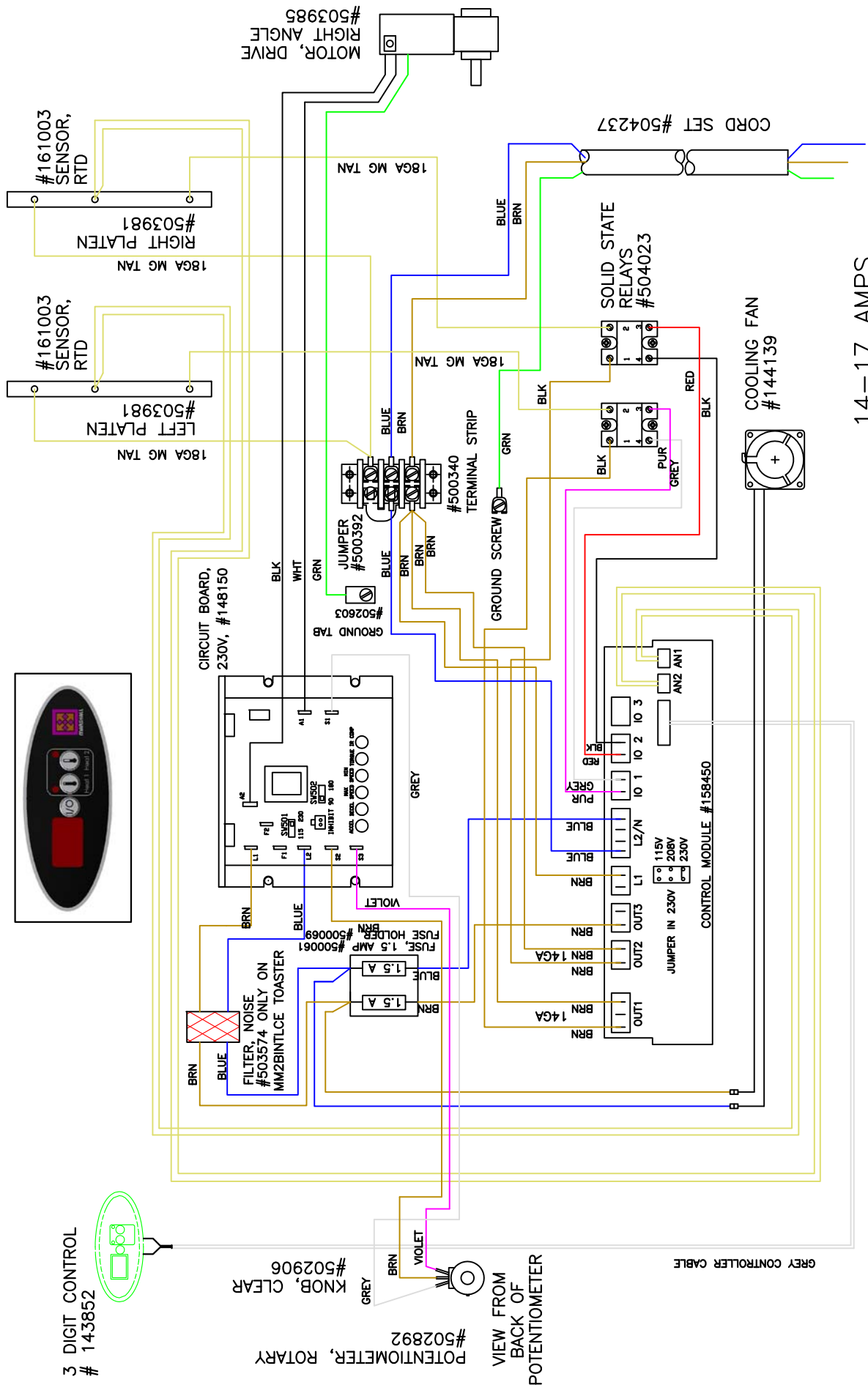

14-17 AMPS

REV	DESCRIPTION	DATE	REV.	BY	DRAWN BY:	DATE:	REV DATE:
1	#161003 WAS #503590	1/22/2013	S.A.		PW	20-SEP-2011	-
2	ADDED CE NOISE FILTER	7/17/2013	PW				
3	ADDED CONTROL TYPE 1 NOTES	4/4/2014	PW				

MARSHALL AIR SYSTEMS, INC.	
SCHEMATIC, HT18 220-240 1PH VARIABLE SPEED	
SIZE: A	ROUTE: ELECT
SCALE: " X . . . . .	IMAGE MAY BE REDUCED
NTS	NTS
CODE: MM2BINTL MM2BINTLC	
DWG. NO.: 158451	REV.: 3

THIS SCHEMATIC IS FOR USE BY A QUALIFIED TECHNICIAN OR ELECTRICIAN ONLY.

**THIS SCHEMATIC FOR GENERATION 1 CONTROLS ONLY (110, HEAT 1, HEAT 2 TO RIGHT OF DISPLAY)**

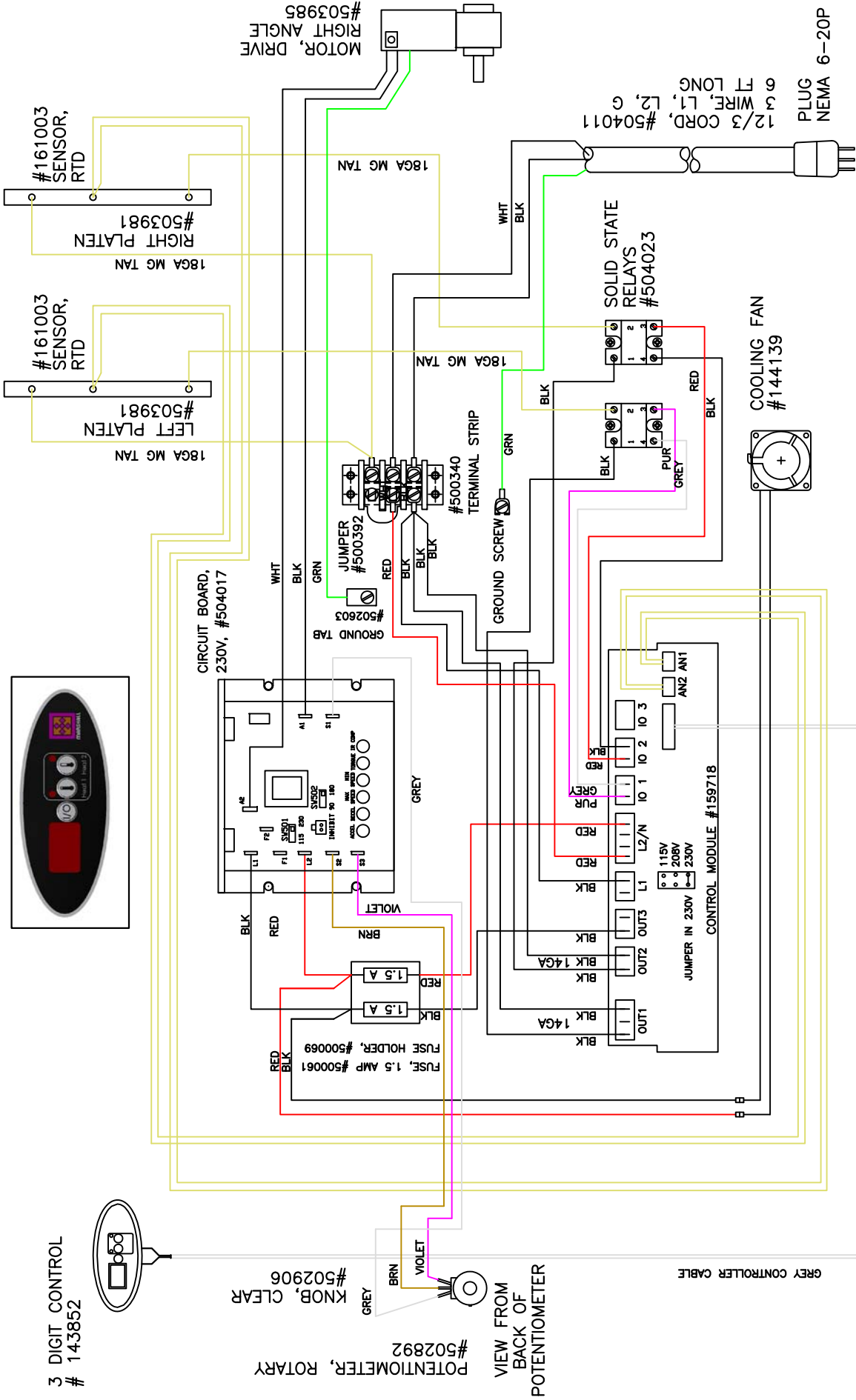

14-17 AMPS

REV	DESCRIPTION	DATE	REV.	BY	DRAWN BY:	DATE:	MARSHALL AIR SYSTEMS, INC.		
1	#161003 WAS #503590	1/22/2013	S.A.		J.L.	6/14/2012	SCHEMATIC, 240V 1PH		
2	ADDED CONTROL TYPE 1 NOTES	4/4/2014	PW				VARIABLE SPEED		
MATERIAL: REFERENCE					PRODUCT CLASS: TST		SIZE: A	ROUTE: ASBY	DWG. NO.: 159717
" X . . . . ."					IMAGE MAY BE REDUCED		SCALE: NTS	CODE: MM2B-1	REV: 2



THIS SCHEMATIC IS FOR USE BY A QUALIFIED TECHNICIAN OR ELECTRICIAN ONLY.

163997

**THIS SCHEMATIC FOR GENERATION 2 CONTROLS ONLY (I/O, HEAT 1, HEAT 2 UNDER DISPLAY)**

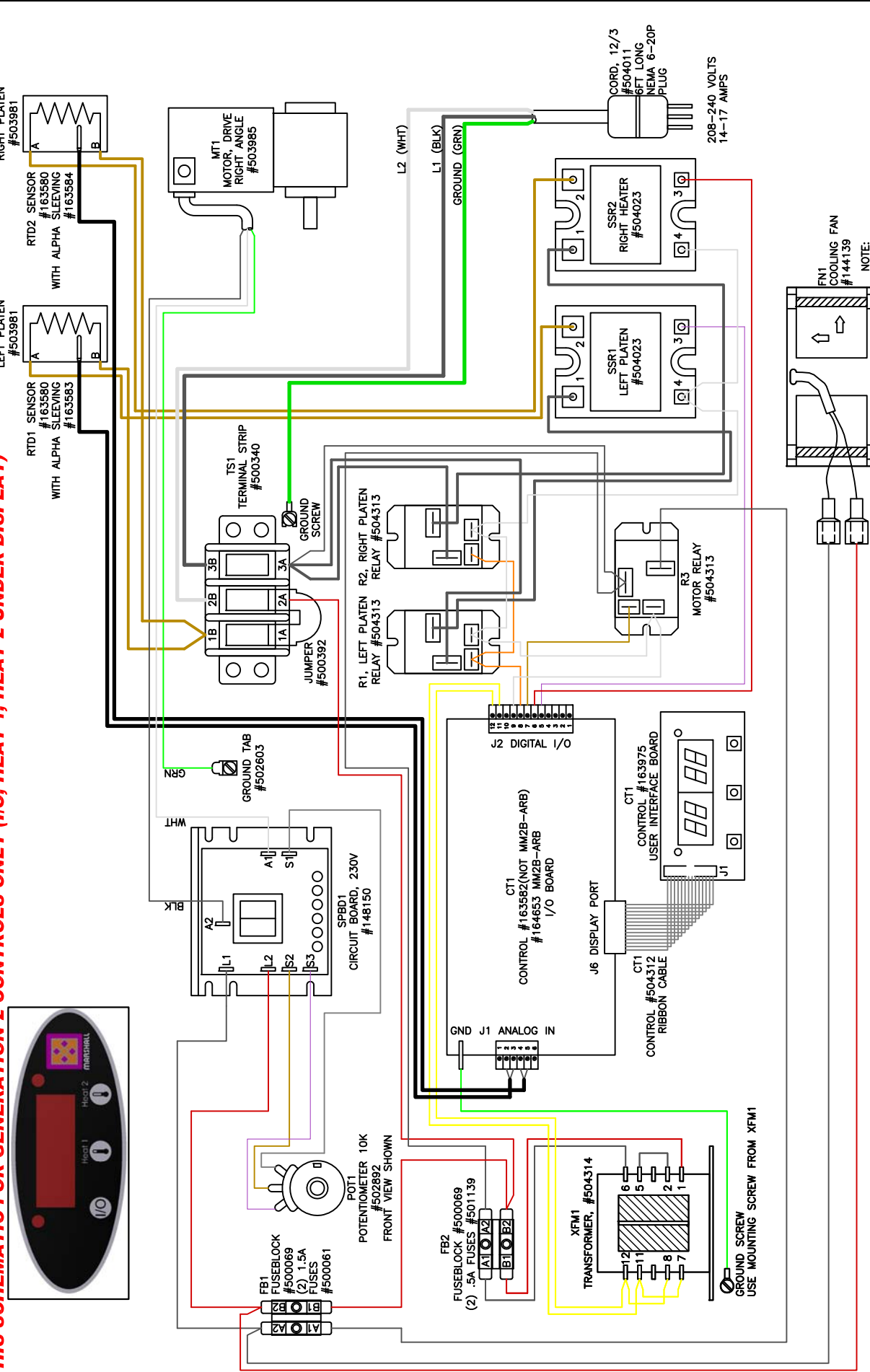

NOTE: 1) SEE DRAWING #163581 FOR WIRE SET

REV	DESCRIPTION	DATE	REV.	BY	DRAWN BY:	DATE:
1	UPDATED FOR NEW COMPONENT LAYOUT	4/16/2014	NG		PW	4/4/2014
2	RE-ORIENTED XFM1, CHG RELAYS GRAY WIRE ROUTING	5/16/2014	S.A.			
3	ADDED MM2B-ARB CONTROL	7/22/2014	PW			

  

<b>MARSHALL AIR SYSTEMS, INC.</b>	
SCHEMATIC, HT18 208 OR 240 1PH VARIABLE SPEED GENERATION 2	
SIZE: A	ROUTE: ELECT
SCALE: " X . . . . ."	DWG. NO.: 163997
IMAGE MAY BE REDUCED	CODE: MM2B-NC MM2B-ARB
NTS	REV: 3

THIS SCHEMATIC IS FOR USE BY A QUALIFIED TECHNICIAN OR ELECTRICIAN ONLY.

164834

**THIS SCHEMATIC FOR GENERATION 2 CONTROLS ONLY (I/O, HEAT 1, HEAT 2 UNDER DISPLAY)**

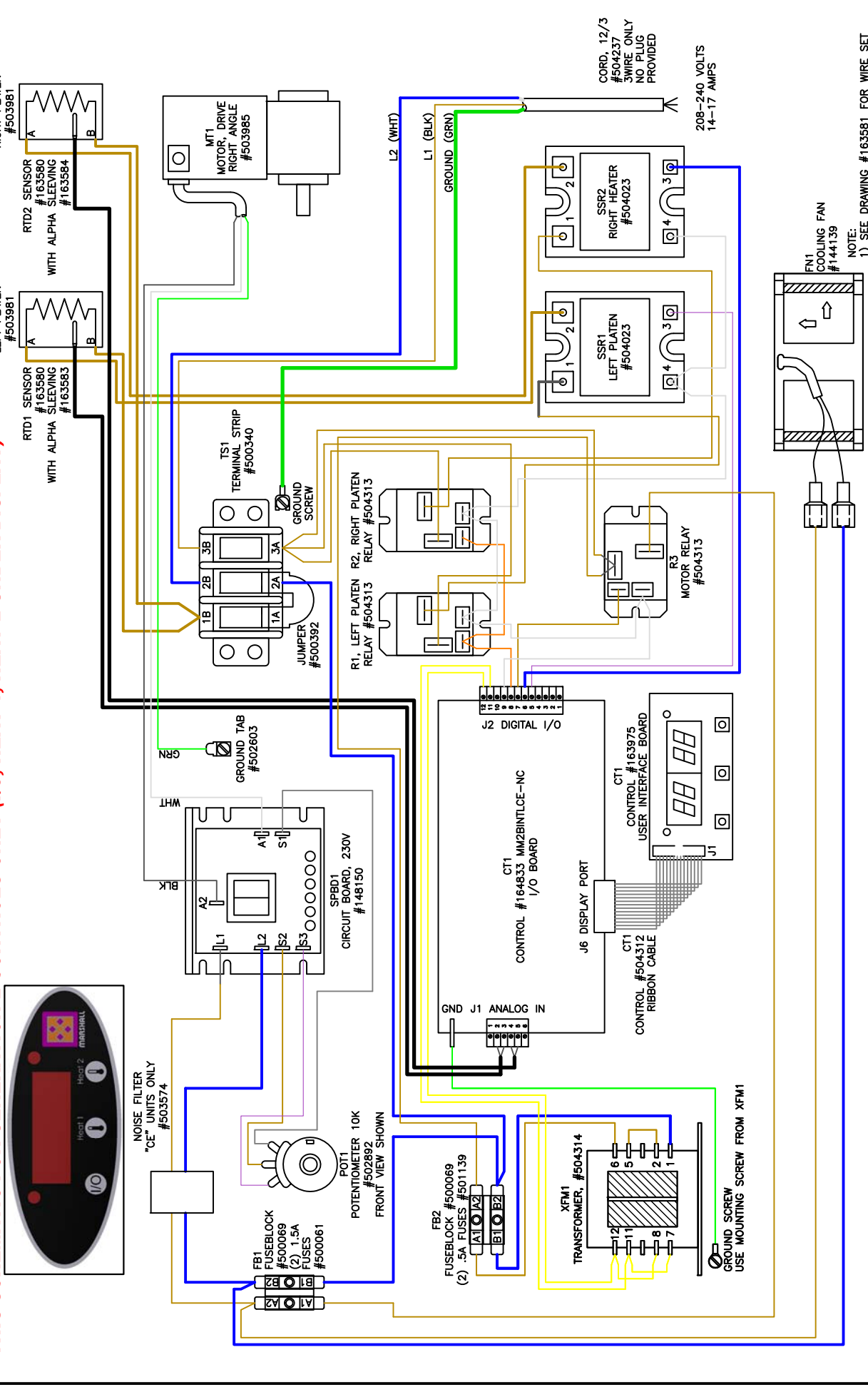

REV	DESCRIPTION	DATE	REV.	BY	DRAWN BY:	DATE:
-	-	-	-	-	PW	9/3/2014
<b>MARSHALL AIR SYSTEMS, INC.</b> SCHEMATIC, HT18 220-240 1PH VARIABLE SPEED GENERATION 2 MATERIAL: REFERENCE SIZE: A ROUTE: ELECT DWG. NO.: 164834 SCALE: " X IMAGE MAY BE REDUCED NTS CODE: MM2BINTL/CE-NC REV.: 0						

THIS SCHEMATIC IS FOR USE BY A QUALIFIED TECHNICIAN OR ELECTRICIAN ONLY.

**THIS SCHEMATIC FOR GENERATION 2 CONTROLS ONLY (I/O, HEAT 1, HEAT 2 UNDER DISPLAY)**

166307

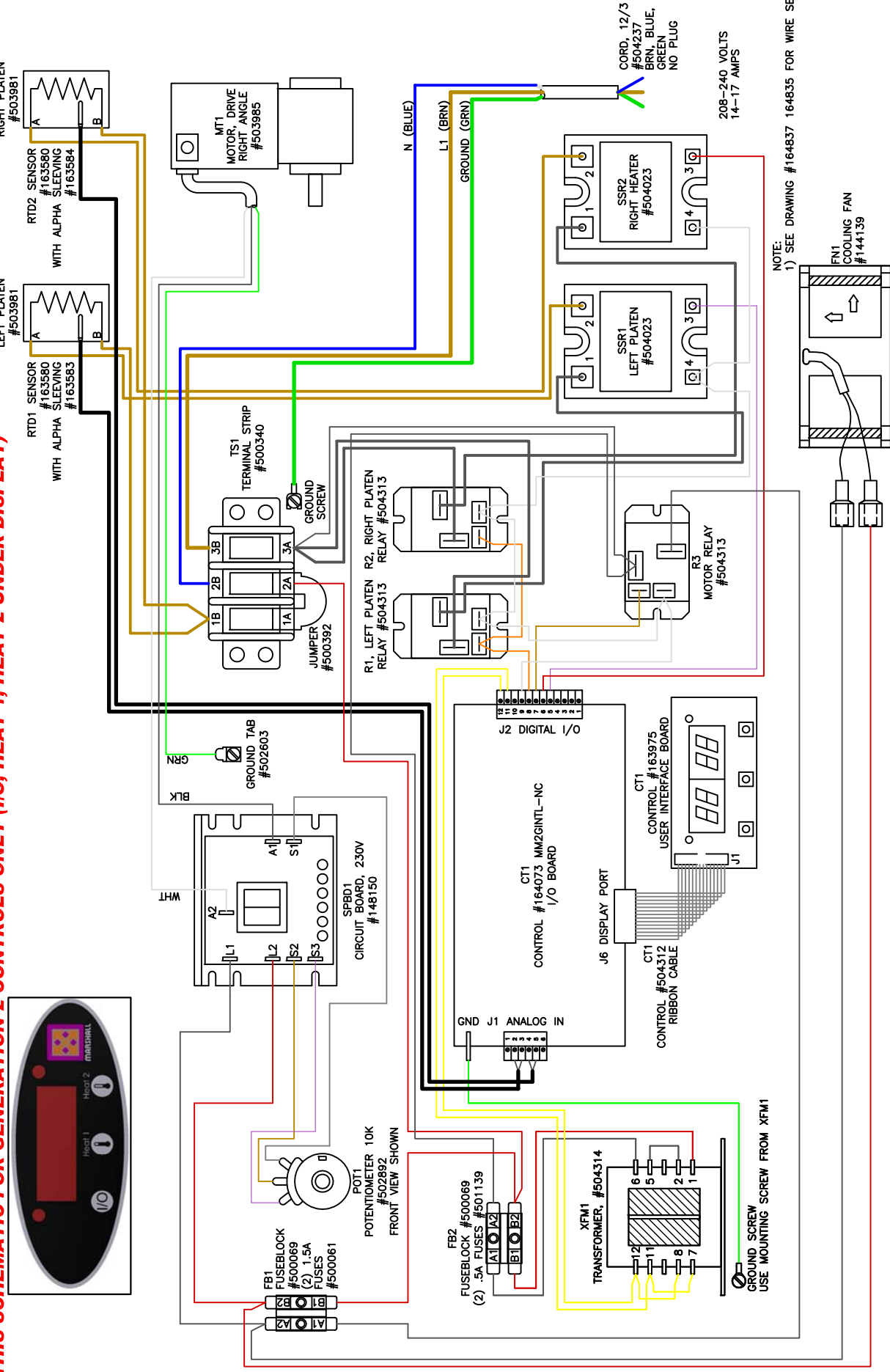

NOTE:  
1) SEE DRAWING #164837 164835 FOR WIRE SET

REV	DESCRIPTION	DATE	REV. BY	DATE	REV.	BY
-	-	-	-	-	-	-

DRAWN BY: PW		DATE: 12/16/2014	
GENERIC NAME: SCHEMATIC			
FAB		PRODUCT CLASS: TST	
MATERIAL: REFERENCE		SIZE: A	
" X "		SCALE: NTS	
" X "		DWG. NO.: 166307	
" X "		REV.: 0	
IMAGE MAY BE REDUCED		CODE: MM2GINTL	

**MARSHALL AIR SYSTEMS, INC.**  
 SCHEMATIC, HT18 208 -240 1PH  
 VARIABLE SPEED GENERATION 2

THIS SCHEMATIC IS FOR USE BY A QUALIFIED TECHNICIAN OR ELECTRICIAN ONLY.

**THIS SCHEMATIC FOR GENERATION 2 CONTROLS ONLY (I/O, HEAT 1, HEAT 2 UNDER DISPLAY)**

166832

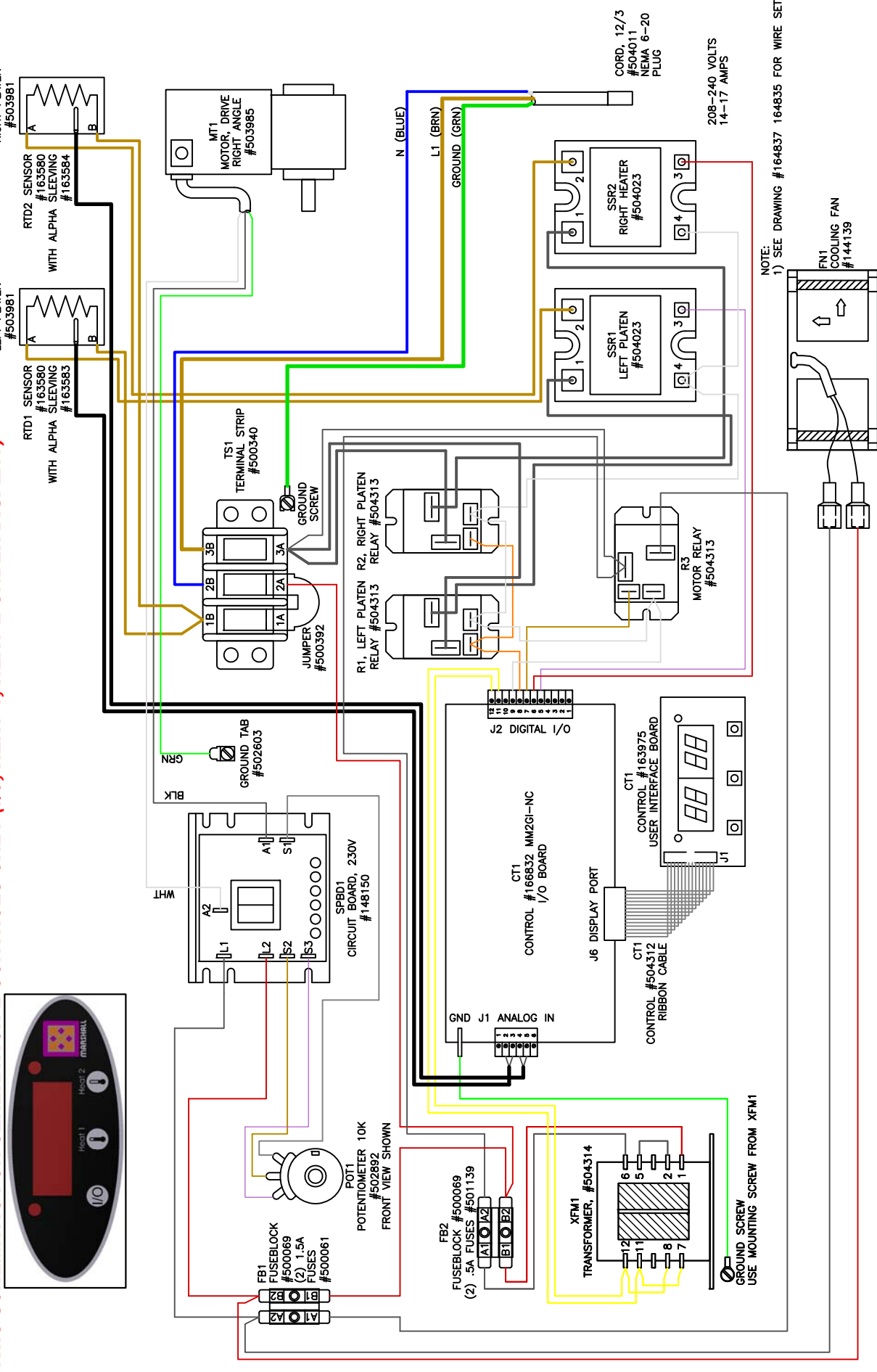

NOTE:  
1) SEE DRAWING #164837 164835 FOR WIRE SET

REV	DESCRIPTION	DATE	REV. BY	DATE	REV.	BY
-	-	-	-	-	-	-

DRAWN BY: PW		DATE: 3/19/2015	
GENERIC NAME: SCHEMATIC			
PRODUCT LINE: TST			
MATERIAL: REFERENCE			
SIZE: A	ROUTE: ELECT	DWG. NO.: 166832	REV.: 0
SCALE: NTS	IMAGE MAY BE REDUCED	CODE: MM2G-NC	

**MARSHALL AIR SYSTEMS, INC.**

SCHEMATIC, HT18 208 -240 1PH  
VARIABLE SPEED GENERATION 2

THIS SCHEMATIC IS FOR USE BY A QUALIFIED TECHNICIAN OR ELECTRICIAN ONLY.

**THIS SCHEMATIC FOR GENERATION 2 CONTROLS ONLY (I/O, HEAT 1, HEAT 2 UNDER DISPLAY)**

169235

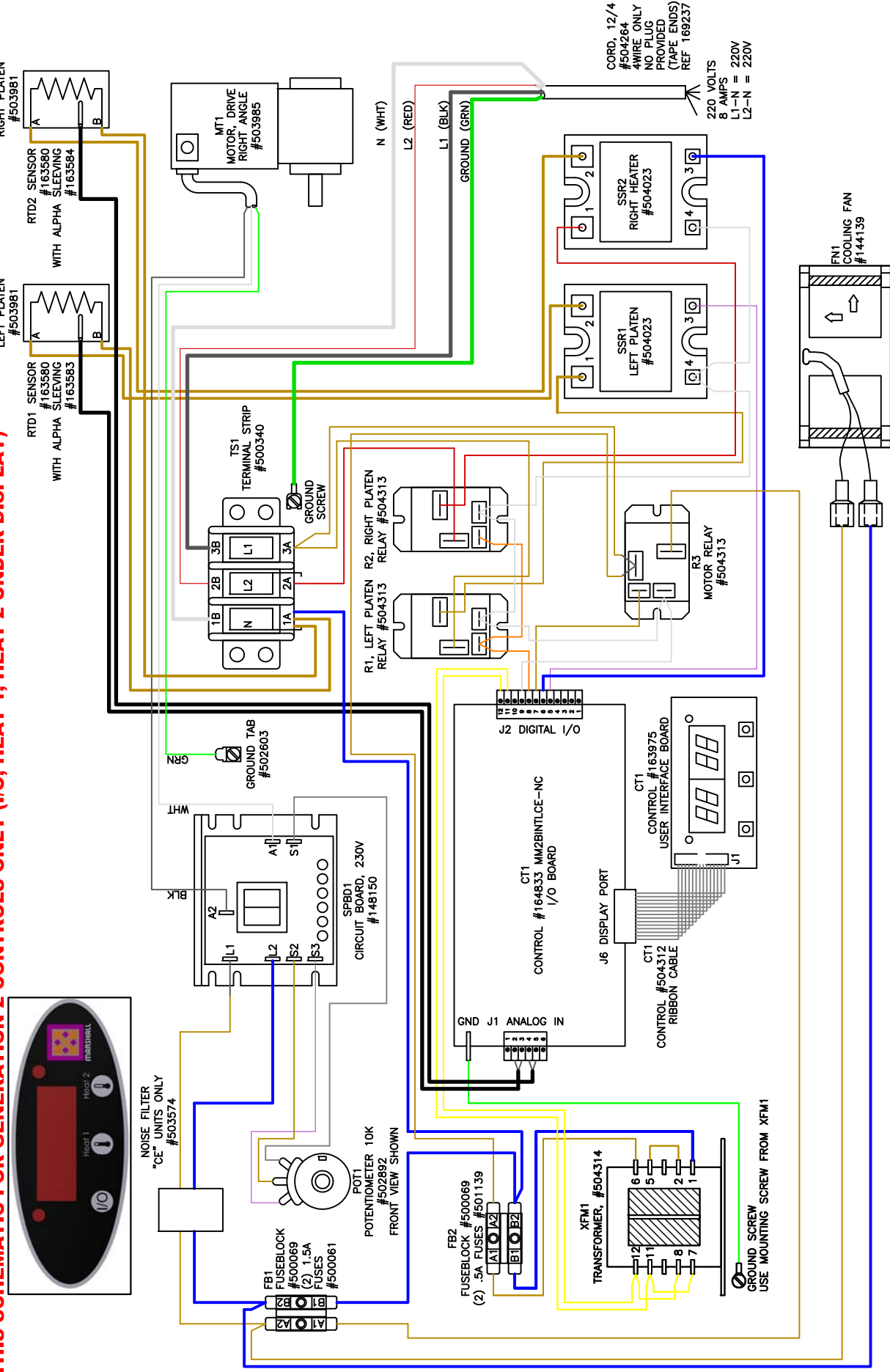

REV	DESCRIPTION	DATE	REV.	BY	DRAWN BY:	DATE:
-	-	-	-	-	PW	1/26/2016
GENERIC NAME: SCHEMATIC PRODUCT CLASS: TST MATERIAL: REFERENCE						
SIZE: A		ROUTE: ELECT		DWG. NO.: 169235		REV.: 0
SCALE: NTS		IMAGE MAY BE REDUCED		CODE: MM2BINTLDMK		

**MARSHALL AIR SYSTEMS, INC.**  
 SCHEMATIC, HT18 220V 1PH 4 WIRE  
 VARIABLE SPEED GENERATION 2

THIS SCHEMATIC IS FOR USE BY A QUALIFIED TECHNICIAN OR ELECTRICIAN ONLY.

167476

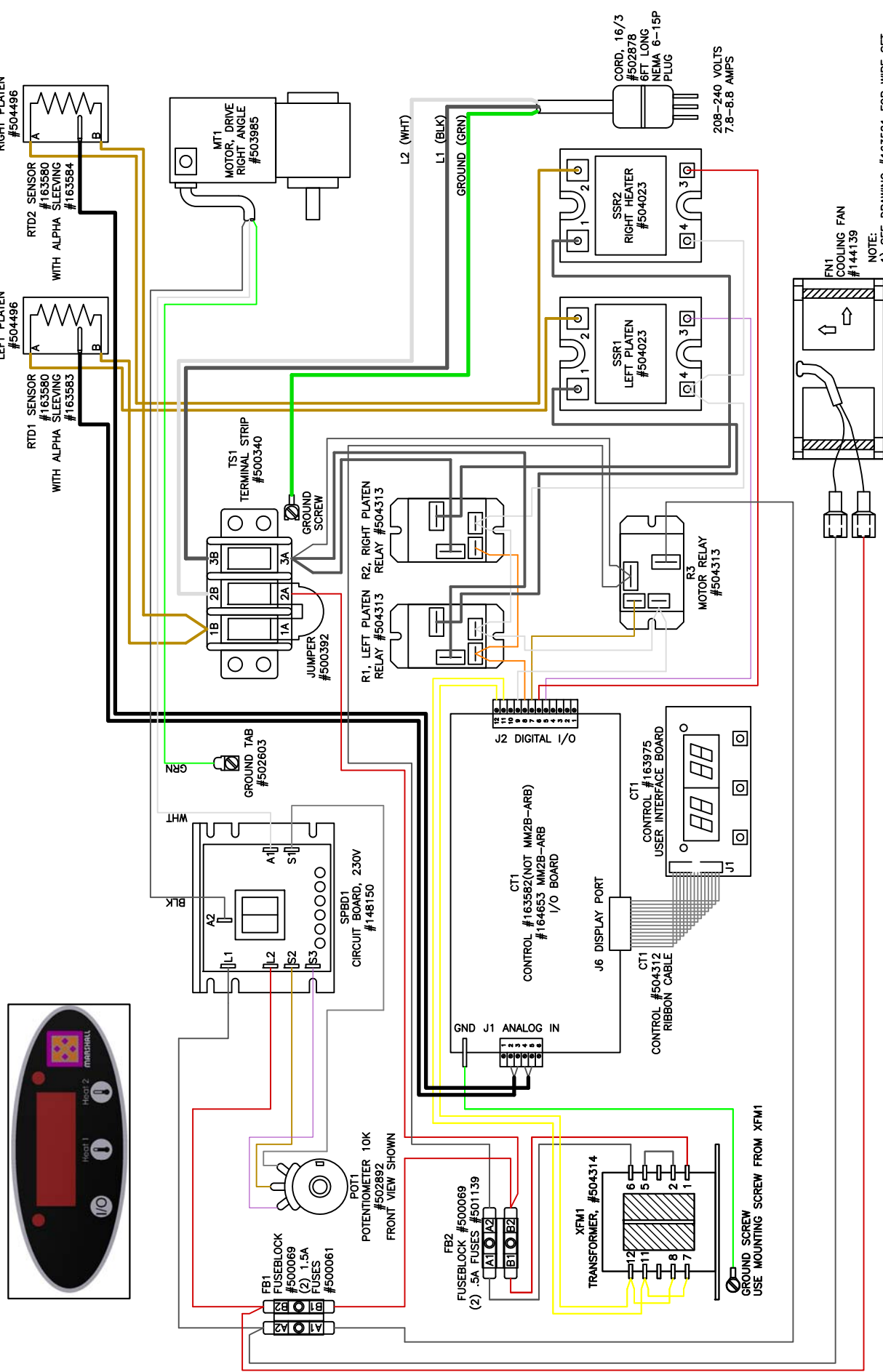

REV	DESCRIPTION	DATE	REV. BY	DATE	REV. BY
1	502878 PLUG WAS 504011	9/3/2015	NG	8/17/2015	NG

DRAWN BY: NG		DATE: 8/17/2015	
GENERIC NAME: SCHEMATIC			
FAB		PRODUCT CLASS: TST	
MATERIAL: REFERENCE		SIZE: ROUTE: ELECT	
" X . . . . ."		SCALE: NTS NTS	
DWG. NO.: 167476		REV.: 1	
CODE: MM2K-ARB		IMAGE MAY BE REDUCED	

**MARSHALL AIR SYSTEMS, INC.**

SCHEMATIC, HT10 208 OR 240 1PH  
VARIABLE SPEED

NOTE: 1) SEE DRAWING #163581 FOR WIRE SET

THIS SCHEMATIC IS FOR USE BY A QUALIFIED TECHNICIAN OR ELECTRICIAN ONLY.

168320

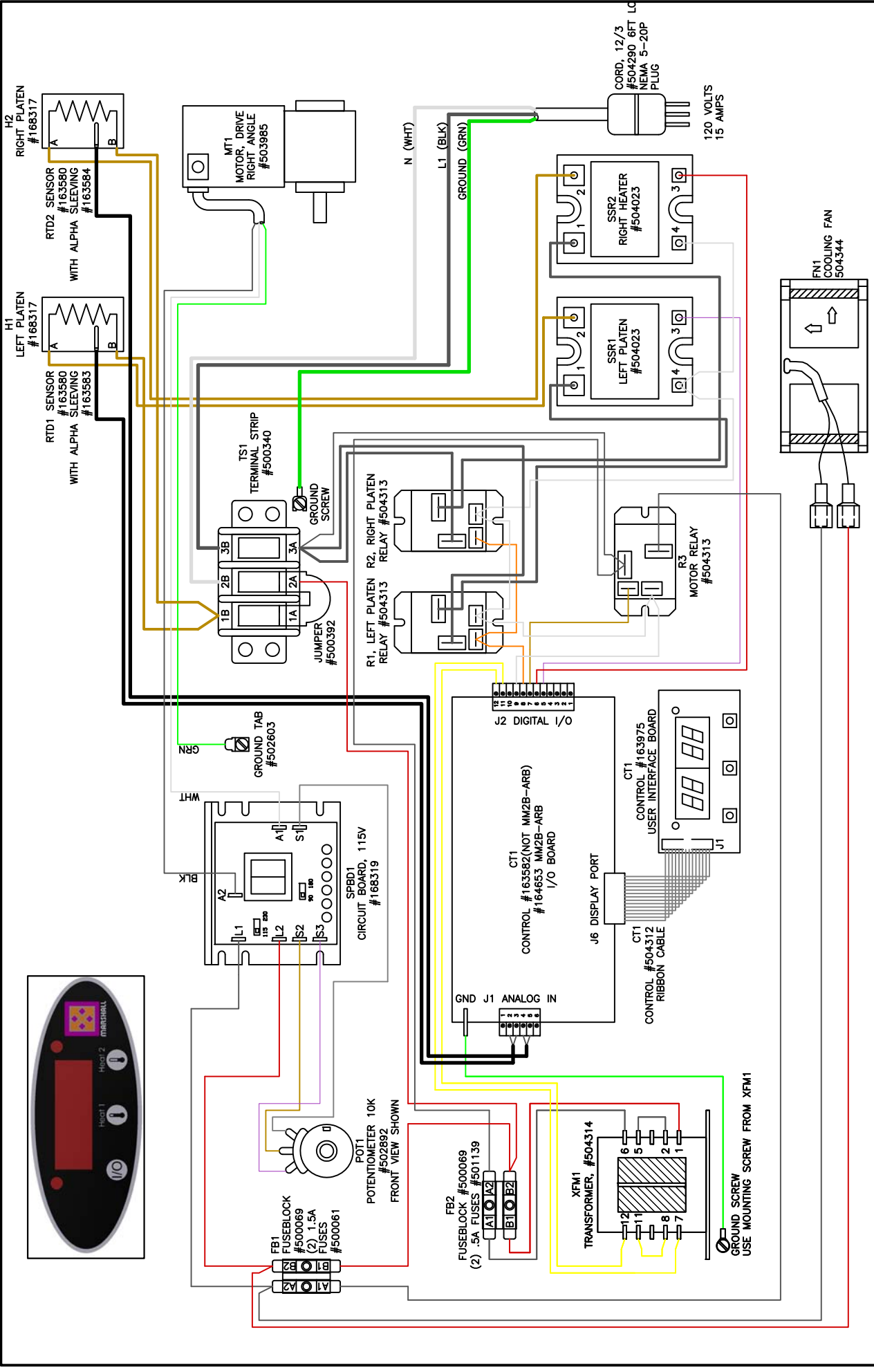

REV	DESCRIPTION	DATE	REV. BY	DATE	REV.
-	-	-	-	-	-
<p>DRAWN BY: PW DATE: 9/10/2015</p> <p>GENERIC NAME: SCHEMATIC</p> <p>PRODUCT LINE: FAB</p> <p>PRODUCT CLASS: TST</p> <p>MATERIAL: REFERENCE</p>					
<p>SIZE: A ROUTE.: ELECT DWG. NO.: 168320 REV.: 0</p> <p>SCALE: NTS IMAGE MAY BE REDUCED CODE: MM2K-120</p>					

**MARSHALL AIR SYSTEMS, INC.**  
 SCHEMATIC, HT10 120V  
 VARIABLE SPEED